

October 2013

# Meridian Road Corridor Study

## Germann Road to McDowell Boulevard

### Final Report

*Prepared for:*



PINAL • COUNTY

*Wide open opportunity*



*Prepared by*

**Baker**

**Michael Baker Jr., Inc.**  
*Phoenix, Arizona*

## Table of Contents

Executive Summary..... vi

    Introduction ..... vi

    Agency, Stakeholder and Public Involvement..... vi

    Traffic Analysis ..... vii

    Purpose and Need..... vii

    Recommended Alternative ..... vii

        Preferred Meridian Road Alignment..... vii

        Preferred Section Line Shift ..... vii

    Design Features..... viii

    Phased Construction ..... ix

        Near-Term Improvement Recommendations..... ix

        Mid-Term Improvement Recommendations ..... ix

        Long-Term Improvement Recommendations..... x

        Ultimate Improvement Recommendations ..... x

    Cost ..... x

I. Introduction ..... 1

    Project Overview..... 1

    Study Area..... 1

    Study Objectives ..... 3

    Vision and Goals..... 3

II. Existing Corridor Features..... 4

    Summary of Existing Plans and Studies ..... 4

    Existing Network and Classification ..... 5

    Existing Features ..... 10

        Drainage ..... 10

        Area Drainage Master Plan ..... 12

        Utilities ..... 13

        Pavement ..... 16

    Existing Land Use ..... 16



Jurisdictions..... 16

Land Use..... 16

Zoning ..... 17

Ownership..... 19

III. Future Corridor Features ..... 21

    Socioeconomic ..... 21

        Planned Land Use..... 21

        Future Land Development ..... 21

        Future Transportation Projects..... 22

        Population and Employment ..... 25

IV. Traffic Analysis Summary ..... 25

    Traffic Analysis Methodology..... 26

    Existing 2012 Traffic Volumes ..... 27

    Existing Level of Service ..... 30

        Existing Roadway Segment Level of Service ..... 30

        Existing Intersection Level of Service..... 30

    Future Traffic Volumes..... 33

    Future Level of Service..... 39

        Future Roadway Segment Level of Service ..... 39

        Future Intersection Level of Service ..... 42

    Traffic Impacts..... 47

V. Environmental Summary ..... 51

    Summary of Socioeconomic Environment Findings ..... 51

    Summary of Physical and Natural Environment Findings..... 51

    Summary of Cultural Inventory Findings ..... 53

VI. Development of Alternatives..... 55

    Alignment Alternatives ..... 55

        Conceptual Analysis for Northern Section of Meridian Road..... 55

        Conceptual Alternatives for Southern Section of Meridian Road ..... 55

        Section Line Shift at Baseline Road ..... 56

VII. Evaluation of Alternatives ..... 59

    Evaluation Criteria..... 59

Alternative Screening ..... 59

Preferred Alternative ..... 60

    Preferred Meridian Road Alignment..... 60

    Preferred Section Line Shift ..... 60

VIII. Design Features..... 61

    Typical Cross Section..... 61

    Phased Construction ..... 63

        Near-Term Improvement Recommendations..... 63

        Mid-Term Improvement Recommendations ..... 64

        Long-Term Improvement Recommendations..... 64

        Ultimate Improvement Recommendations ..... 64

    Access Management Recommendations..... 65

        Intersection Spacing..... 65

        Driveway Locations ..... 65

        Median Locations..... 65

        Additional Recommendations ..... 67

    Right-Of-Way..... 67

        Existing Right-of-Way..... 67

        Required Right-of-Way ..... 69

IX. Cost ..... 70

X. Agency, Stakeholder and Public Involvement..... 74

    Technical Advisory Committee ..... 74

    Stakeholder Coordination ..... 74

    Public Outreach..... 75

    Public Meeting ..... 76

XI. Planning and Environmental Linkage (PEL)..... 76

**List of Figures**

Figure 1: Study Area..... 2

Figure 2: Existing Number of Lanes..... 6

Figure 3: Posted Speed Limits..... 7

Figure 4: Existing 2012 Intersection Lane Configuration and Control Type ..... 8

Figure 5: Existing FHWA Functional Classification ..... 9

Figure 6: Existing Drainage Features..... 11

Figure 7: Existing Utilities..... 15

Figure 8: Existing Land Uses..... 18

Figure 9: Existing Land Ownership ..... 20

Figure 10: Future Land Uses ..... 24

Figure 11: Existing 2012 Average Daily Traffic Volumes ..... 28

Figure 12: Existing 2012 Turning Movement Volumes ..... 29

Figure 13: 2012 Average Daily Level of Service ..... 31

Figure 14: Existing 2012 Intersection Level of Service..... 32

Figure 15: Future 2025 Daily Traffic Volumes..... 35

Figure 16: Future 2035 Daily Traffic Volumes..... 36

Figure 17: Future 2025 Turning Movement Volumes..... 37

Figure 18: Future 2035 Turning Movement Volumes..... 38

Figure 19: 2025 Average Daily Level of Service ..... 40

Figure 20: 2035 Average Daily Level of Service ..... 41

Figure 21: 2025 Intersection Lane Configuration ..... 43

Figure 22: 2035 Intersection Lane Configuration ..... 44

Figure 23: 2025 Intersection Level of Service ..... 45

Figure 24: 2035 Intersection Level of Service ..... 46

Figure 25: 2025 Recommended Roadway Configuration ..... 49

Figure 26: 2035 Recommended Roadway Configuration ..... 50

Figure 27: Conceptual Alternatives for Southern Section of Meridian Road ..... 57

Figure 28: Section Line Shift at Baseline Road Alternatives ..... 58

Figure 29: Ultimate Roadway Cross Section – Southern Avenue to Germann Road..... 61

Figure 30: Ultimate Roadway Cross Section – Lost Dutchman Boulevard to Southern Avenue ..... 62

Figure 31: Ultimate Roadway Cross Section – Lost Dutchman Boulevard to McDowell Boulevard..... 62

Figure 32: Interim Cross Section: McDowell Boulevard to Lost Dutchman Boulevard ..... 63

Figure 33: Interim Cross Section: Lost Dutchman Boulevard to Germann Road..... 63

Figure 34: Interim Cross Section: Southern Avenue to Germann Road ..... 63

**List of Tables**

Table 1: Summary of Collected Documentation ..... 5

Table 2: Existing Crossing Facilities within the Study Area ..... 10

Table 3: Utility Stakeholders within the Meridian Road Corridor ..... 13

Table 4: Project Influence Area Population Projections ..... 25

Table 5: Level of Service Criteria:      Table 6: Level of Service Criteria: ..... 26

Table 7: 2012 Average Daily Traffic Volumes ..... 27

Table 8: Annual Average Daily Volume Threshold Values for Various Facility Types ..... 30

Table 9: 2025 and 2035 Daily Traffic Volumes..... 34



Table 10: Annual Average Daily Volume Threshold Values for Varies Facility Types .....	39
Table 11: 2025 Meridian Road Intersection Lane Configuration Deviations.....	47
Table 12: 2035 Meridian Road Intersection Lane Configuration Deviations.....	48
Table 13: Leaking Underground Storage Tank Locations .....	52
Table 14: Resource Conservation and Recovery Act (RCRA) Facilities .....	53
Table 15: Alternative Screening Results .....	60
Table 16: Access Control Guidelines per Jurisdiction (for Urban Arterial Roads).....	66
Table 17: Existing Right-of-Way .....	68
Table 18: Right-of-Way Requirements.....	69
Table 19: Summary of Corridor Segment Estimates.....	70
Table 20: Itemized Cost Estimate for Near-Term Recommendations .....	71
Table 21: Itemized Cost Estimate for the Northern Segment under Mid-Term Recommendations: McDowell Boulevard to Southern Avenue .....	71
Table 22: Itemized Cost Estimate for the Northern Segment under Long-Term Recommendations: McDowell Boulevard to Southern Avenue .....	72
Table 23: Itemized Cost Estimate for the Preferred Corridor under Mid/Long-Term Recommendations: Southern Avenue to Germann Road.....	72
Table 24: Itemized Cost Estimate for the Preferred Corridor under Ultimate Recommendations: Southern Avenue to Germann Road.....	73

## List of Appendices

Appendix A	Working Paper #1: Existing and Future Conditions Inventory
Appendix B	Working Paper #2: Evaluation Criteria and Plan for Improvements
Appendix C	Final Meridian Road Corridor Study Public Involvement Report
Appendix D	Sample Memorandum of Understanding
Appendix E	Meeting Notes
Appendix F	Planning/Environmental Linkages Questionnaire

## Executive Summary

### Introduction

The proposed Meridian Road Corridor Study is needed to support the continuing development and growth, occurring and anticipated, in the East Mesa, West Apache Junction, and within Pinal County. Significant growth is anticipated in this region that could result in population growth, economic development, and increased traffic volumes. The purpose of the Meridian Road Corridor Study is to document conditions along the existing roadway and to develop alternatives that will increase the safety and future level of service (LOS) of Meridian Road. This study will also establish a roadway footprint and develop the ultimate right-of-way requirement for the corridor. Finally, the study will be utilized as a guide for local agencies and future development along the corridor.

The study area for the Meridian Road Corridor Study is approximately 13 miles in length and is generally bounded by Germann Road on the south, McDowell Boulevard on the north, Ironwood Road on the east and Signal Butte Road on the west. Meridian Road is a section line alignment road that is located on the boundary between Pinal County and Maricopa County. The Cities of Apache Junction and Mesa and the Counties of Maricopa and Pinal along with the Town of Queen Creek all control portions of Meridian Road. Although Arizona State Land Department (ASLD) does not control portions of Meridian Road, ASLD does own a majority of the land to the east of Meridian Road, south of Baseline Road.

### Agency, Stakeholder and Public Involvement

A Technical Advisory Committee (TAC) was established to solicit feedback from partnering agencies and key stakeholders at multiple stages of the corridor study. The following agencies are represented on this Committee:

- Pinal County
- City of Apache Junction
- City of Mesa
- Central Arizona Governments
- Maricopa County Department of Transportation
- Federal Highway Administration
- Arizona Department of Transportation Environmental Planning
- Maricopa County Flood Control District
- Town of Queen Creek
- Maricopa Association of Governments
- Arizona State Land Department
- Arizona Department of Transportation, Multimodal Planning Division
- Arizona Department of Transportation, Communications and Community Partnerships

Several TAC meetings were held over the course of the study to discuss general project overview, define the Planning and Environmental Linkages Program, discuss corridor specific issues, present the project schedule and solicit feedback from participating TAC members in regards to *Working Paper #1: Existing and Future Conditions Inventory* and *Working Paper #2: Evaluation Criteria and Plan for Improvements*.

Representatives from the TAC, Arizona State Land Department, Entellus and LTM Engineering met on a number of occasions to discuss the update to the East Mesa Area Drainage Master Plan (ADMP), along with coordination efforts between the two projects and how both projects will affect ASLD property.

Consensus was reached that the Meridian Road alignment should be on section line and that the flood control facility (channel) should stay upstream (or east) of the Meridian Road corridor and that the Meridian Road Corridor Study can reference the forthcoming ADMP update to this point.

### Traffic Analysis

The results of the 2025 and 2035 LOS analysis for a roadway segment indicate that most segments of Meridian Road will operate unacceptably as a three-lane section. By year 2025, it is anticipated that Meridian Road will operate within the threshold of acceptable operations at a LOS of C or better as a two-lane undivided roadway between McDowell Boulevard and Lost Dutchman Boulevard, as a three-lane section south of Lost Dutchman Boulevard to Southern Avenue and as four-lane divided roadway south of Southern Avenue to Germann Road. By year 2035, it is anticipated that Meridian Road between Lost Dutchman Boulevard to Southern Avenue will need to be improved to a four-lane divided roadway to operate within the threshold of acceptable operations at a LOS of C or better.

### Purpose and Need

The purpose of this study is to evaluate the growing demands placed on local roads and streets by development in the region. The study will address the transportation planning needs identified by the jurisdictions and more particularly to lead the local jurisdictions to develop consensus on socio-economic demographic, modeling forecasts, roadway facility type, number of lanes, and right-of-way requirements to guide the future development of the road. The purpose and need of the project is to provide transportation capacity to serve future travel demand needed to support the continuing development and growth, occurring and anticipated, in the East Mesa, West Apache Junction, and within Pinal County.

### Recommended Alternative

The development and evaluation of alternatives were based upon information collected and documented in the Working Papers, jurisdiction design guidelines and criteria, input received from the Meridian Road TAC and input received during the public open houses.

### Preferred Meridian Road Alignment

All three of the build alternatives are anticipated to have similar amount of constructability issues related to traffic control and maintenance of traffic during construction. Minimal environmental issues are anticipated with all the alternatives. Input received on the alternatives from the TAC at the meeting and a subsequent agency meeting with ASLD was generally in favor of the alignment staying on the section line because it resulted in more equitable right-of-way takes from property owners and did not place a large burden on State Trust Land. The Meandering Alignment (Alternative 4) was selected as the preferred alternative because it followed the section line for most of its length except the area between Williams Field Road and Pecos Road where the alignment shifted east to avoid impacting existing residential developments.

### Preferred Section Line Shift

Based on the input received from the TAC team and engineering considerations the preferred alternative for the two reverse curve alignments would be the US 60 to Baseline Road Section Line Shift



Alternative (Alternative B1). While there was no real preferences between the alternatives from the TAC team, both were considered viable alignments, the alignment south of Baseline Road would pass through an area of land subsidence and earth fissures. In addition, consideration has to be given to the provision of a traffic interchange (TI) with US 60. Currently a half-TI consisting of a partial cloverleaf with ramps to/from the west is proposed. A new study is proposed by ADOT to investigate the provision of additional general purpose lanes along US 60. As part of this study the location of a full interchange will be examined. Preliminary work suggest that the TI will be placed west of the existing Meridian Road bridge and probably line up with the section line south of Baseline Road.

**Design Features**

There are four separate jurisdictions within the Meridian Road Corridor, each with their own set of design guidelines. Those jurisdictions are the City of Apache Junction, City of Mesa, Maricopa County and Pinal County. In order to address the needs and purposes of the Meridian Road Corridor Study, a consensus had to be reached between the Local agencies/jurisdictions and private stakeholders regarding the preferred interim and ultimate facility type and access control design elements.

At this time the local agencies have not determined which of them will have the ultimate responsibility for what segments of Meridian Road. When that decision is made, and when the road is improved, the lead agencies design standards will govern the development of the roadway. Until that time, the agencies generally agree to the guidelines presented in the typical cross sections below.

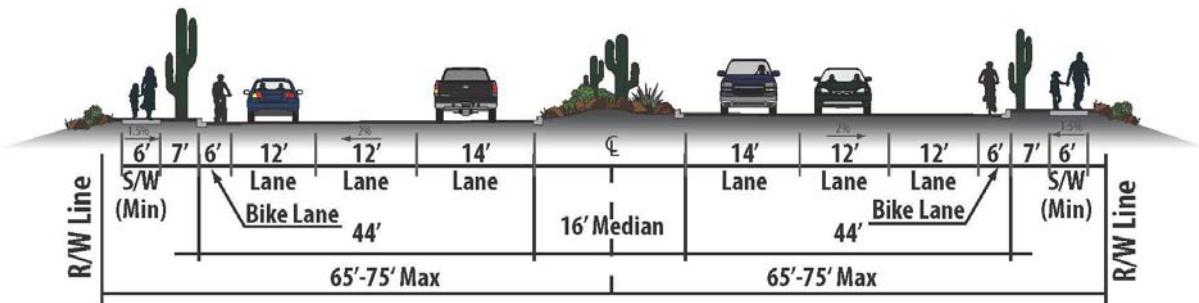

**Figure ES-1: Ultimate Roadway Cross Section – Southern Avenue to Germann Road**

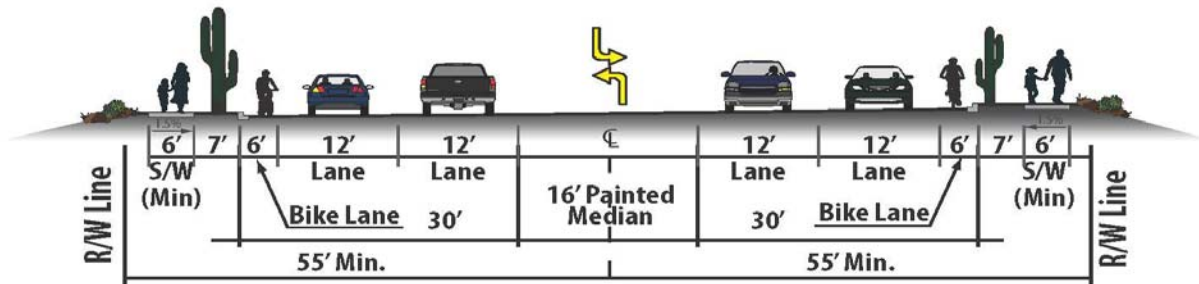

**Figure ES-2: Ultimate Roadway Cross Section – Lost Dutchman Boulevard to Southern Avenue**

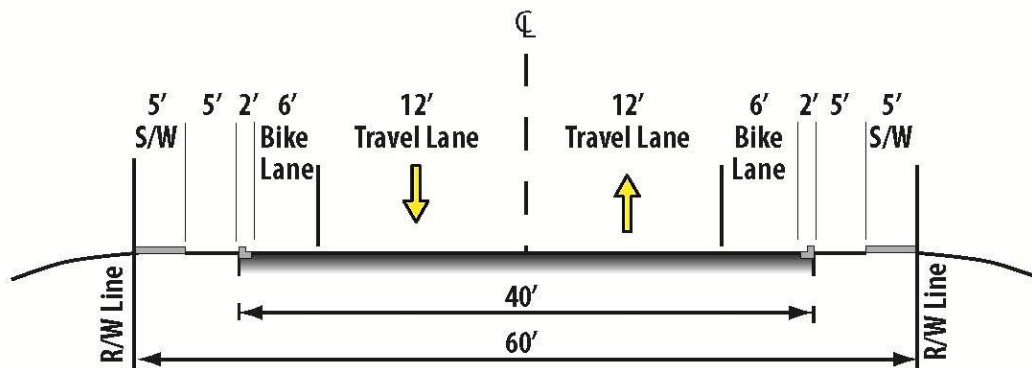

Figure ES-3: Ultimate Roadway Cross Section – Lost Dutchman Boulevard to McDowell Boulevard

## Phased Construction

### Near-Term Improvement Recommendations

Based on the traffic analysis results and the projected development patterns, the following improvements are either programmed or recommended for the near-term (by 2017), although the timing of these improvements will be dependent on the surrounding area development:

- The US 60/Meridian Road Traffic Interchange is programmed to be constructed by 2017;
- The Southern Avenue/Meridian Road intersection is programmed to be signalized by 2017 and widened to accommodate a left-turn lane and a shared through/right-turn lane in each direction; and
- By 2017, Meridian Road is recommended to be extended from Baseline Road to Elliot Road with intersection improvements at Baseline Road, Guadalupe Road and Elliot Road to improve connectivity within the corridor with the addition of programmed improvements.

### Mid-Term Improvement Recommendations

Based on the development pattern projected by the Maricopa Association of Governments (MAG), the following improvements are anticipated to occur in the mid-term (2017-2025), although the timing of these improvements will be dependent on the surrounding area development:

- Meridian Road is anticipated to be widened to a three-lane roadway from Lost Dutchman Boulevard to Southern Avenue;
- Meridian Road is anticipated to be widened to a four-lane divided roadway from Southern Avenue to Elliot Road; and
- Meridian Road is anticipated to be extended from Warner Road to Germann Road as a four-lane divided roadway by 2025 including constructing Meridian Road intersections with Ray Road, Williams Field Road, Pecos Road and Germann Road as well as the SR 24/Meridian Road Traffic Interchange.

With the gaps that currently exist in Meridian Road likely to be filled during the mid-term timeframe, this will result in a continuous arterial with freeway access to US 60. These improvements are

anticipated to significantly alter traffic volumes on Meridian Road as well as along some of the adjacent parallel arterials, such as Ironwood Road.

**Long-Term Improvement Recommendations**

Based on the development pattern projected by MAG, the following improvements are anticipated to occur in the mid-term (2025-2035), although the timing of these improvements will be dependent on the surrounding area development:

- Meridian Road is anticipated to be widened to a four-lane roadway from Lost Dutchman Boulevard to Southern Avenue; and
- The SR 24/Meridian Road Traffic Interchange is anticipated to be constructed by 2035.

**Ultimate Improvement Recommendations**

The following improvement is anticipated to occur in the ultimate condition (beyond 2035), although the timing of these improvements will be dependent on the surrounding area development:

- Meridian Road is anticipated to be widened to the full six-lane cross-section between Southern Avenue and Germann Road.

**Cost**

Preliminary cost estimates for roadway construction and right-of-way acquisition were prepared for the corridor alternatives. **Table ES-1** presents the order of magnitude cost estimate for the northern section of the corridor plus the alternatives for the southern section of the corridor. Detailed estimates for the corridor alternative may be found in *Working Paper #2: Evaluation Criteria and Plan for Improvements*.

**Table ES-1: Summary of Corridor Segment Estimates**

Phased Construction	Northern Section	Southern Section Alternatives			
		Alternative 1	Alternative 2	Alternative 3	Alternative 4
Near-Term	\$ -	\$ -	\$5,210,947	\$5,210,947	\$5,210,947
Mid/Long-Term	\$20,344,040	\$ -	\$25,613,040	\$28,956,720	\$25,613,040
Ultimate	\$ -	\$ -	\$11,394,480	\$12,524,640	\$11,394,480
<b>Total Cost (Northern plus Southern)</b>	<b>\$ -</b>	<b>\$ -</b>	<b>\$62,562,507</b>	<b>\$67,036,347</b>	<b>\$62,562,507</b>

**Table ES-2** presents the itemized cost estimate for the near-term improvements of the Meridian Road Corridor. **Table ES-3** and **Table ES-4** presents the itemized cost estimate for the northern segment of the Meridian Road Corridor between McDowell Boulevard and Southern Avenue for under the mid-term and long-term recommendations, respectively. **Table ES-5** and **Table ES-6** present the itemized cost estimate for the southern segment’s preferred Meridian Road Corridor between Southern Avenue and Germann Road under the mid/long-term and ultimate recommendations, respectively.



Table ES-2: Itemized Cost Estimate for Near-Term Recommendations

Item	Item Description	Unit	Unit Price	Quantity	Total
-	(Segment Length)	MILES	-	2	-
1	New Pavement	SY	\$32.00	46934	\$1,501,888
2	Earthwork	LSUM	N/A	25% of Item 1	\$375,472
3	Drainage	LSUM	N/A	15% of Item 1	\$225,283
4	Structures	LSUM	\$500,000.00	0	\$ -
5	Maintenance of Traffic	LSUM	N/A	10% of Items 1-3	\$210,264
6	Lighting	LSUM	N/A	5% of Items 1-3	\$105,132
7	Signing/Signals	LSUM	N/A	15% of Items 1-3	\$315,396
8	Utilities	LSUM	N/A	5% of Items 1-3	\$105,132
9	Incidental Work	LSUM	N/A	15% of Items 1-3	\$315,396
<b>Total Construction Cost =</b>					<b>\$3,153,965</b>
10	ROW Acquisition	ACRE	\$20,000.00	16	\$320,000
11	Design & Construction Management	LSUM	N/A	25% of Item 1-10	\$868,491
12	Contingency	LSUM	N/A	25% of Item 1-10	\$868,491
<b>Order of Magnitude Project Cost =</b>					<b>\$5,210,947</b>

\*Cost excludes Meridian Road TI and Southern Avenue intersection improvements

Table ES-3: Itemized Cost Estimate for the Northern Segment under Mid-Term Recommendations: McDowell Boulevard to Southern Avenue

Item	Item Description	Unit	Unit Price	Quantity	Total
-	(Segment Length)	MILES	-	5.5	-
1	New Pavement	SY	\$32.00	129067	\$4,130,144
2	Earthwork	LSUM	N/A	5% of Item 1	\$206,507
3	Drainage	LSUM	N/A	15% of Item 1	\$619,522
4	Structures	LSUM	\$500,000.00	0	\$ -
5	Maintenance of Traffic	LSUM	N/A	10% of Items 1-3	\$495,617
6	Lighting	LSUM	N/A	1% of Items 1-3	\$49,562
7	Signing/Signals	LSUM	N/A	10% of Items 1-3	\$495,617
8	Utilities	LSUM	N/A	15% of Items 1-3	\$743,426
9	Incidental Work	LSUM	N/A	15% of Items 1-3	\$743,426
<b>Total Construction Cost =</b>					<b>\$7,483,821</b>
10	ROW Acquisition	ACRE	\$20,000.00	25	\$500,000
11	Design & Construction Management	LSUM	N/A	25% of Item 1-10	\$1,995,955
12	Contingency	LSUM	N/A	25% of Item 1-10	\$1,995,955
<b>Order of Magnitude Project Cost =</b>					<b>\$11,975,731</b>

**Table ES-4: Itemized Cost Estimate for the Northern Segment under Long-Term Recommendations:  
McDowell Boulevard to Southern Avenue**

Item	Item Description	Unit	Unit Price	Quantity	Total
-	(Segment Length)	MILES	-	5.5	-
1	New Pavement	SY	\$32.00	96214	\$3,078,848
2	Earthwork	LSUM	N/A	5% of Item 1	\$153,942
3	Drainage	LSUM	N/A	15% of Item 1	\$461,827
4	Structures	LSUM	\$500,000.00	0	\$ -
5	Maintenance of Traffic	LSUM	N/A	10% of Items 1-3	\$369,462
6	Lighting	LSUM	N/A	1% of Items 1-3	\$36,946
7	Signing/Signals	LSUM	N/A	10% of Items 1-3	\$369,462
8	Utilities	LSUM	N/A	15% of Items 1-3	\$554,193
9	Incidental Work	LSUM	N/A	15% of Items 1-3	\$554,193
<b>Total Construction Cost =</b>					<b>\$5,578,873</b>
10	ROW Acquisition	ACRE	\$20,000.00	0	\$ -
11	Design & Construction Management	LSUM	N/A	25% of Item 1-10	\$1,394,718
12	Contingency	LSUM	N/A	25% of Item 1-10	\$1,394,718
<b>Order of Magnitude Project Cost =</b>					<b>\$8,368,309</b>

**Table ES-5: Itemized Cost Estimate for the Preferred Corridor under Mid/Long-Term  
Recommendations: Southern Avenue to Germann Road**

Item	Item Description	Unit	Unit Price	Quantity	Total
-	(Segment Length)	MILES	-	7.5	-
1	New Pavement	SY	\$32.00	228800	\$7,321,600
2	Earthwork	LSUM	N/A	25% of Item 1	\$1,830,400
3	Drainage	LSUM	N/A	15% of Item 1	\$1,098,240
4	Structures	LSUM	\$500,000.00	1	\$500,000
5	Maintenance of Traffic	LSUM	N/A	10% of Items 1-3	\$1,025,024
6	Lighting	LSUM	N/A	5% of Items 1-3	\$512,512
7	Signing/Signals	LSUM	N/A	15% of Items 1-3	\$1,537,536
8	Utilities	LSUM	N/A	5% of Items 1-3	\$512,512
9	Incidental Work	LSUM	N/A	15% of Items 1-3	\$1,537,536
<b>Total Construction Cost =</b>					<b>\$15,875,360</b>
10	ROW Acquisition	ACRE	\$20,000.00	60	\$1,200,000
11	Design & Construction Management	LSUM	N/A	25% of Item 1-10	\$4,268,840
12	Contingency	LSUM	N/A	25% of Item 1-10	\$4,268,840
<b>Order of Magnitude Project Cost =</b>					<b>\$25,613,040</b>

**Table ES-6: Itemized Cost Estimate for the Preferred Corridor under Ultimate Recommendations:  
Southern Avenue to Germann Road**

Item	Item Description	Unit	Unit Price	Quantity	Total
-	(Segment Length)	MILES	-	7.5	-
1	New Pavement	SY	\$32.00	105600	\$3,379,200
2	Earthwork	LSUM	N/A	25% of Item 1	\$844,800
3	Drainage	LSUM	N/A	15% of Item 1	\$506,880
4	Structures	LSUM	\$500,000.00	1	\$500,000
5	Maintenance of Traffic	LSUM	N/A	10% of Items 1-3	\$473,088
6	Lighting	LSUM	N/A	5% of Items 1-3	\$236,544
7	Signing/Signals	LSUM	N/A	15% of Items 1-3	\$709,632
8	Utilities	LSUM	N/A	5% of Items 1-3	\$236,544
9	Incidental Work	LSUM	N/A	15% of Items 1-3	\$709,632
<b>Total Construction Cost =</b>					<b>\$7,596,320</b>
10	ROW Acquisition	ACRE	\$20,000.00	0	\$ -
11	Design & Construction Management	LSUM	N/A	25% of Item 1-10	\$1,899,080
12	Contingency	LSUM	N/A	25% of Item 1-10	\$1,899,080
<b>Order of Magnitude Project Cost =</b>					<b>\$11,394,480</b>



## I. Introduction

### Project Overview

Continued development along the Meridian Road corridor will lead to significant traffic increases in the future. Currently, there are only two north-south roadways that connect US 60 to Hunt Highway. The closest through route is Ironwood Drive, one mile east of Meridian Road. The other through route, Ellsworth Road, is three miles west. If either of these roads becomes obstructed, significant traffic delays will occur because no intermediate thoroughfare exists.

Meridian Road has been identified in the long range transportation plans of all local agencies plus the Maricopa Association of Governments (MAG). The principal focus of the Meridian Road Corridor Study is to address the transportation planning needs identified by the jurisdictions and more particularly to lead the local jurisdictions to develop consensus on facility type, number of lanes and right-of-way requirements to guide the future development of the road. This could be memorialized through an intergovernmental agreement or a memorandum of understanding.

### Study Area

The study area for the Meridian Road Corridor Study is approximately 13 miles in length and is generally bounded by Germann Road on the south, McDowell Boulevard on the north, Ironwood Road on the east and Signal Butte Road on the west. Meridian Road is a section line alignment road that is located on the boundary between Pinal County and Maricopa County. The Cities of Apache Junction and Mesa and the Counties of Maricopa and Pinal along with the Town of Queen Creek all control portions of Meridian Road. Although Arizona State Land Department (ASLD) does not control portions of Meridian Road, ASLD does own a majority of the land to the east of Meridian Road, south of Baseline Road. Currently, Meridian Road is a discontinuous road within the study area. Meridian Road is a paved two-lane roadway from McDowell Boulevard to Baseline Road and between a half mile north of Elliot Road and a half mile south of Warner Road. The remaining segments of Meridian Road within the study area are a discontinuous dirt road.

The study area is depicted in **Figure 1**.

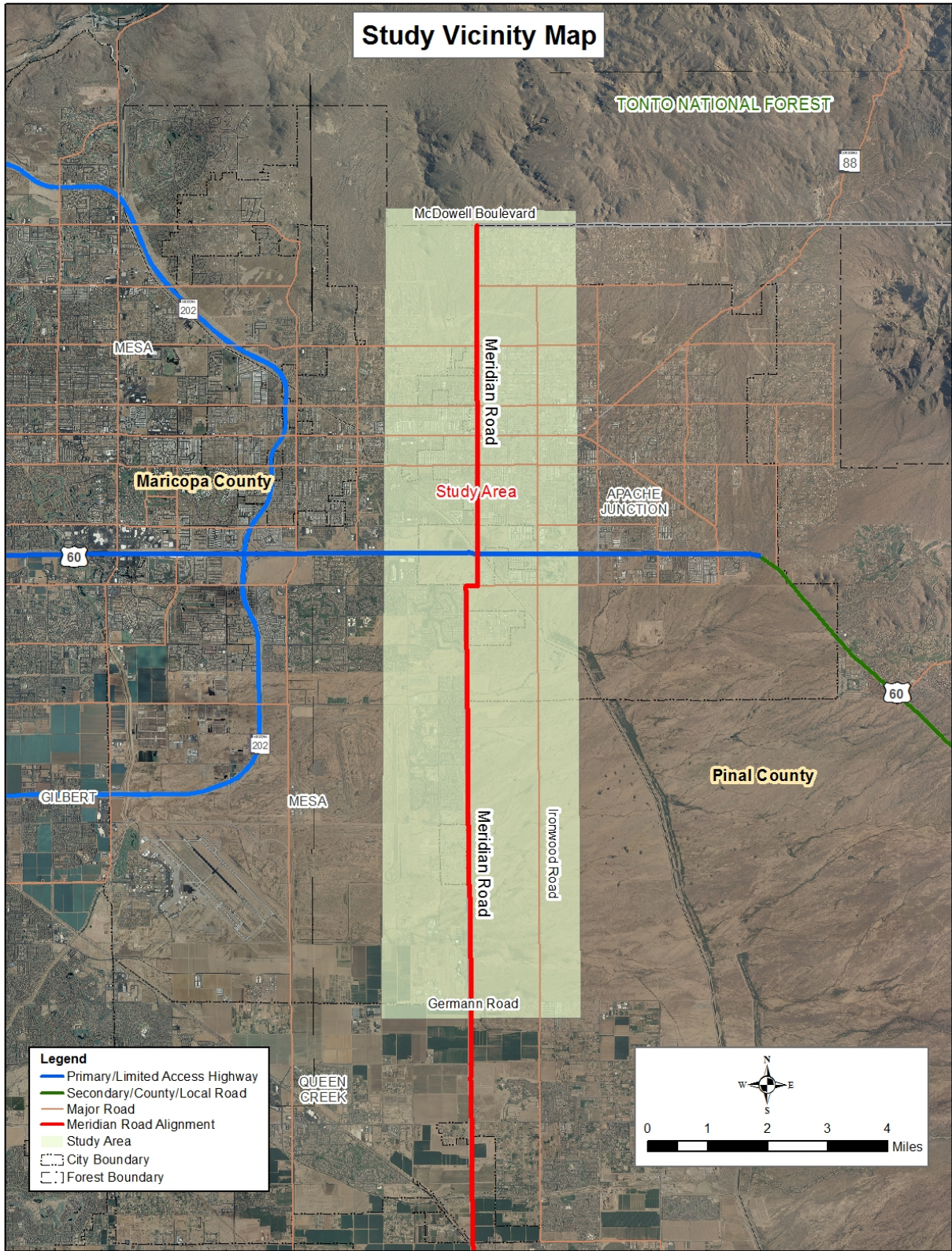

Figure 1: Study Area



## Study Objectives

The purpose of the Meridian Road Corridor Study is to document conditions along the existing roadway and to develop alternatives that will increase the safety and future level of service (LOS) of Meridian Road. This study will also establish a roadway footprint and develop the ultimate right-of-way requirement for the corridor. Finally, the study will be utilized as a guide for local agencies and future development along the corridor.

In order to address the needs and purposes of the Meridian Road Corridor Study a number of goals and objectives were agreed to with Stakeholders during the kick-off meeting. These goals and objectives area as follows:

- Identify and address planning level issues prior to the initiation programming and engineering design.
- Evaluate the future transportation needs of the corridor and identify the facility type, and the number of interim and ultimate lanes.
- Develop an implementation plan to bring about the recommended improvements, while acknowledging the need for sufficient flexibility to adapt to future changes.
- Identify and evaluate a preferred alignment within the southern portion of the corridor.
- Determine the required right-of-way requirements for the corridor
- To establish a consensus among the local agencies/jurisdictions and private stakeholders regarding the preferred interim and ultimate facility type, and access control design elements for the corridor.
- Document the preferred facility location/concept alternatives and provide the necessary planning input to enable ADOT and the local agencies to move forward in the design and environmental process.

## Vision and Goals

The proposed project is needed to support the continuing development and growth, occurring and anticipated, in the East Mesa, West Apache Junction, and within Pinal County. Significant growth is anticipated in this region that could result in population growth, economic development, and increased traffic volumes. The purpose of this study is to evaluate the growing demands placed on local roads and streets by development in the region. The study will address the transportation planning needs identified by the jurisdictions and more particularly to lead the local jurisdictions to develop consensus on socio-economic demographic, modeling forecasts, roadway facility type, number of lanes, and right-of-way requirements to guide the future development of the road. The study will also include roadway improvement phasing plans, cost estimates and implementation plans. Additionally, the study will examine multimodal opportunities necessary to accommodate growth and development, such as, bicycle and pedestrian needs.

## II. Existing Corridor Features

This section provides an overview of existing corridor features for the Meridian Road Corridor study area as documented in available plans, reports, and studies. Additional information is available in *Working Paper #1: Existing and Future Conditions Inventory*.

### Summary of Existing Plans and Studies

Related plans, reports and studies completed during the last 10 years were collected to compile available information and data pertinent to the Meridian Road Corridor Study. The purpose of this review is to gain an understanding of current issues and future plans within the study area. This chapter summarizes the available relevant information on existing and future conditions as contained in the plans, reports and studies collected. **Table 1** provides a listing of the reports and studies that were obtained and reviewed as part of the Meridian Road Corridor Study including document type, date completed, and agency/jurisdiction.

**Table 1: Summary of Collected Documentation**

Doc. Type	Jurisdiction Agency	Author/Originator	Document Title	Date
Report	Arizona Department of Transportation, City of Apache Junction	Jacobs	Apache Junction Transit Feasibility Study Update	Jun-12
Report	Arizona Department of Transportation, City of Apache Junction	Jacobs	Apache Junction Comprehensive Transportation Study	May-12
Report	Arizona Department of Transportation	HDR Engineering, Inc.	North-South Corridor Study Draft Purpose and Need	Dec-11
Report	Arizona Department of Transportation	N/A	Germann Road Corridor Improvement Study Power Road to Ironwood Road A Planning Assistance for Rural Areas Study Phase I Public Involvement Report	Dec-11
PARA Study Application	Arizona Department of Transportation	Pinal County	Meridian Road Corridor Study	Aug-11
Report	Arizona Department of Transportation	N/A	State Route 802, Williams Gateway Freeway Final Environmental Assessment and Appendices	Apr-11
Report	Arizona State Land Department	Robert Grow Consulting	Superstition Vistas: Final Report and Strategic Actions	Spring 2011
Exhibit	Arizona State Land Department	N/A	Pinal County (Superstition Vistas) Proposed Comprehensive Plan Amendment	May-11
Report	Arizona State Land Department	Jackie Guthrie & Associates	Superstition Vistas: Pinal County Comprehensive Plan Amendment	Jun-11
Memorandum	Arizona State Land Department	Robert Charles Lesser & Company, Inc.	Underlying Assumptions and Argument in Support of Household and Employment Growth Projections for Superstition Vistas Arizona State Trust Land	May-09
Report	Arizona State Land Department	Robert Grow Consulting	Superstition Vistas: Environmental Armature Concept Summary	Apr-09
White Paper	N/A	EDAW Inc.	Superstition Vistas Water Strategy White Paper	Apr-09
White Paper	N/A	Kimley-Horn and Associates, Inc.	Superstition Vistas Transportation Planning White Paper	N/A
White Paper	N/A	Fregonese Associates	Superstition Vistas White Paper: Land Use Scenario Development	Mar-09
Report	City of Mesa	HDR Engineering, Inc.	Mesa Gateway Strategic Development Plan: Transportation Analysis Memorandum	Jan-09
Report	City of Mesa	N/A	City of Mesa Transportation Plan	Jun-02
Plans	Flood Control District of Maricopa County; City of Mesa	Stanley Consultants, Inc.	Siphon Draw Improvements Phase 2	Apr-09
Plans	Flood Control District of Maricopa County; City of Mesa	Stanley Consultants, Inc.	Siphon Draw Improvements Phase 1	Jan-09
Plans	Maricopa County Department of Transportation	YSMA Transportation Engineering Solutions	Intersection Improvements of Southern Avenue and Meridian Road	Jul-11
Book of Summaries	Maricopa County Department of Transportation	N/A	2010 Maricopa County Department of Transportation Corridor Studies Book of Summaries	Jan-11
Report	Maricopa County Department of Transportation	EPS Group, Inc.	Signal Butte Corridor Improvement Study: US 60 to Rittenhouse Road	Dec-09
Memorandum of Understanding	Maricopa County Department of Transportation, City of Mesa	N/A	Memorandum of Understanding Between Maricopa County and the City of Mesa for Plan Review, Plan Approval, Permitting, Inspection, Construction, Annexation, Operation and Maintenance of Elliot Road from Power Road to Meridian Road	Aug-08
Report	Maricopa County Department of Transportation	Kimley-Horn and Associates, Inc.	Elliot Road Corridor Improvement Study: Power Road to the Central Arizona Project Canal	Jun-08
Report	Maricopa County Department of Transportation	URS	Meridian Road Access Control and Corridor Improvement Study	Jan-06
Report	Pinal County	Nygaard/Nelson Consulting Associates	Pinal County Transit Feasibility Study Final Report	Apr-11
Report	Pinal County	Lima & Associates	Regionally Significant Routes for Safety and Mobility	Dec-08
Report	Pinal County	Kirkham Michael Consulting Engineers	Pinal County Small Area Transportation Study Final Report	Aug-06
Report	Pinal County	Kirkham Michael Consulting Engineers	Pinal County Small Area Transportation Study Final Transit Element Report	Aug-06
Report	Town of Queen Creek	Cambridge Systematics, Inc.	Queen Creek Small Area Transportation Study	May-07

**Existing Network and Classification**

A field review was conducted to inventory the existing number of lanes, posted speed limits, intersection lane configurations and traffic control type. The resulting information is depicted in **Figure 2**, **Figure 3** and **Figure 4** respectively.

Functional classification is the grouping of streets and highways into classes according to the character of service in which they are intended to provide. **Figure 5** depicts the current FHWA approved functional classification for roadways within the study area.

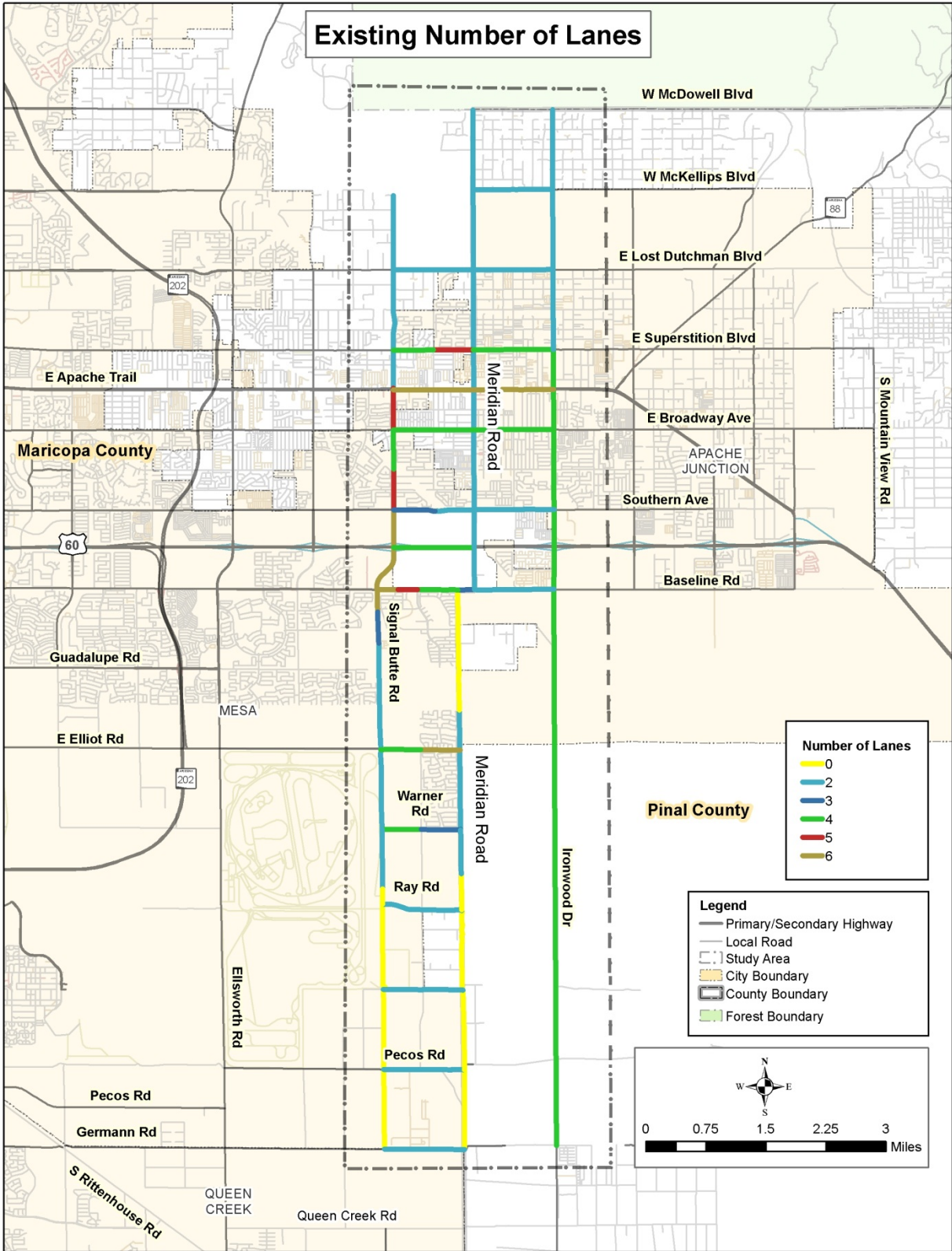
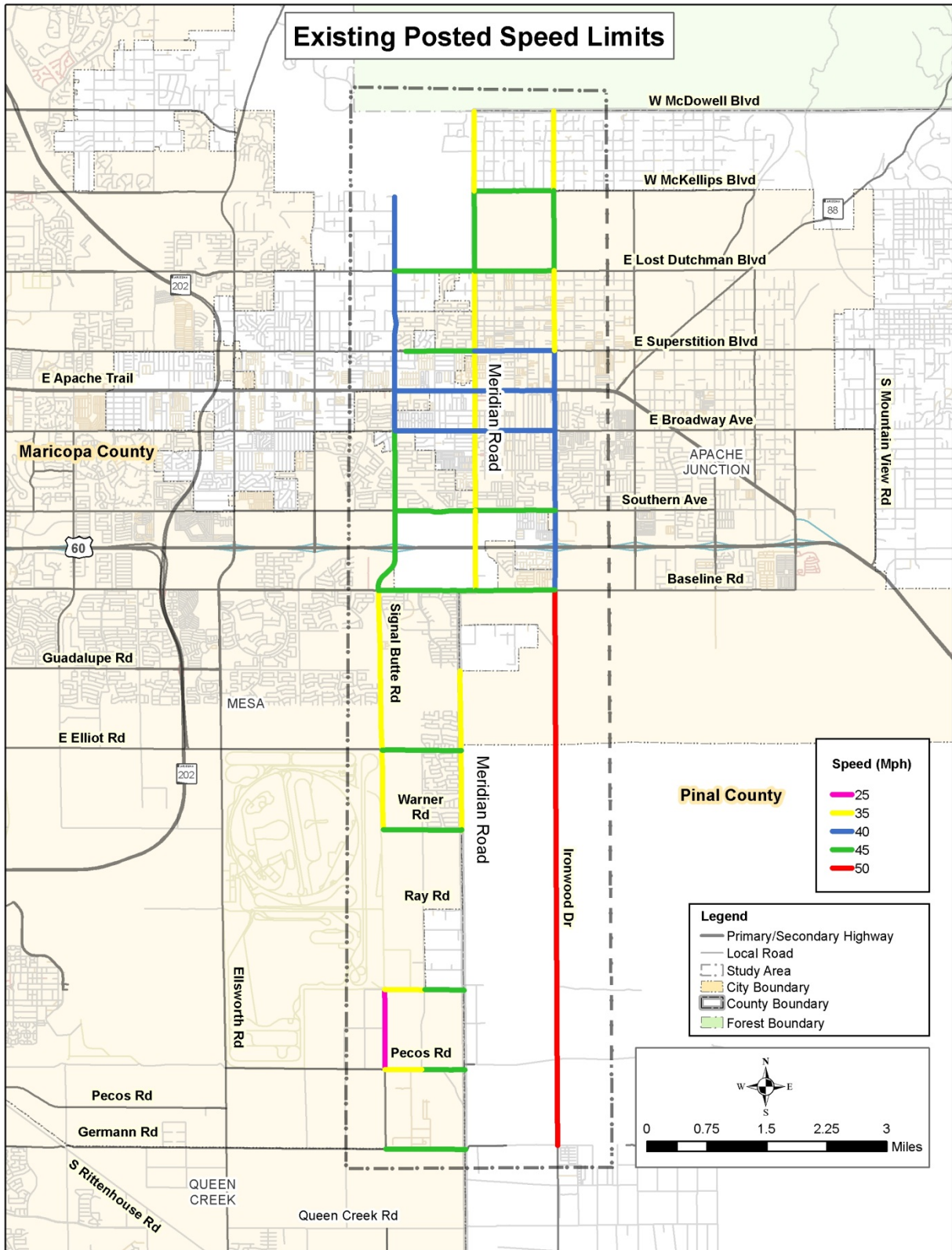

Figure 2: Existing Number of Lanes



**Figure 3: Posted Speed Limits**



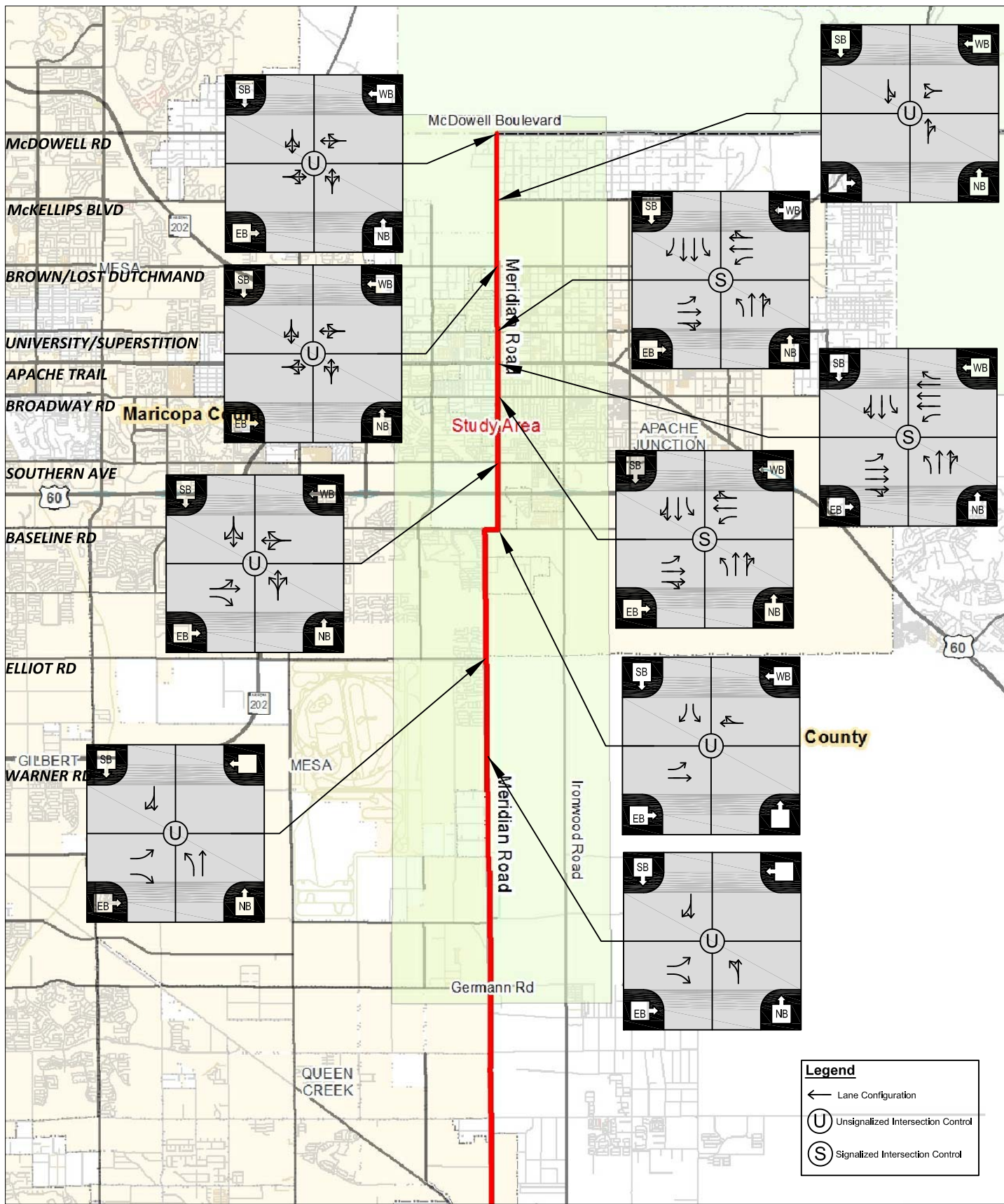

Figure 4  
Existing 2012 Intersection Lane Configuration & Control Type

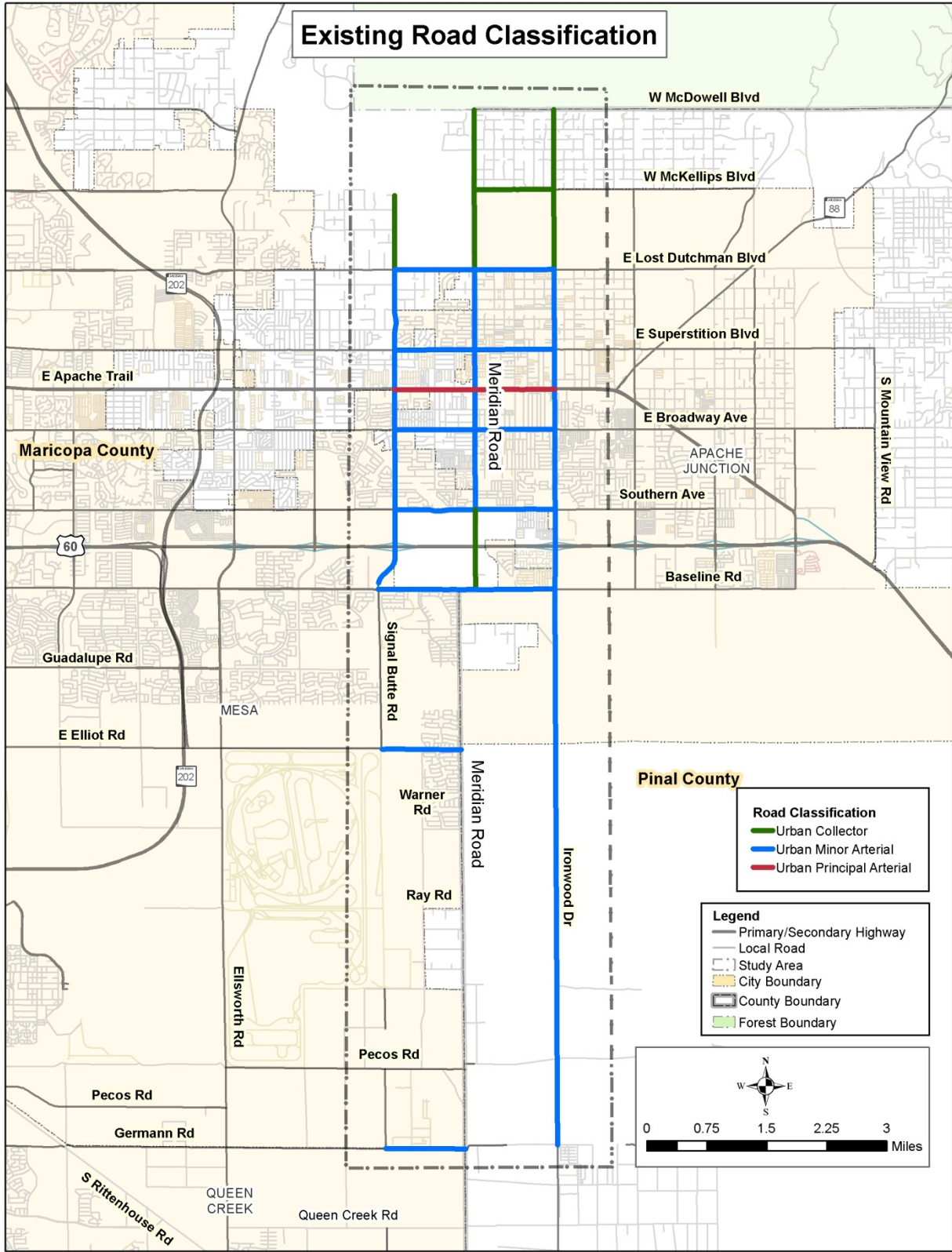

Figure 5: Existing FHWA Functional Classification

## Existing Features

The following sections summarize an inventory of existing features within the study area. Additional information is available in *Working Paper #1: Existing and Future Conditions Inventory*.

### Drainage

Existing drainage features within the study corridor include several watersheds, floodplain, washes, flood control projects, bridges, culverts, low water crossings and the Central Arizona Project (CAP) Canal which crosses at US 60. Runoff throughout the area generally flows from northeast to southwest. Meridian Road, from McDowell Boulevard south, is generally the boundary between Maricopa County and Pinal County. Watershed runoff that originates in Pinal County flows into Maricopa County, crossing Meridian Road. All existing flood control projects along the Meridian Road project corridor belong to the Flood Control District of Maricopa County (FCDMC), with intent to mitigate flooding impacts of upstream watersheds on Maricopa County property. **Figure 6** shows all existing crossing facilities within the project corridor. These crossings are identified in **Table 2** and include three FCDMC Projects: Signal Butte Flood Retarding Structure (FRS) and Floodway, the Siphon Draw Drainage improvements, and the Powerline FRS and Floodway.

**Table 2: Existing Crossing Facilities within the Study Area**

Crossing No.	Structure	Description	Location
1	18" RCP	existing cross-drainage	0.2 miles south of McDowell Blvd.
2	3-8' x 4' RCBC's	existing cross-drainage	0.1 miles north of Whiteley St.
3	Low Water Crossing	existing cross-drainage	0.2 miles south of McKellips Blvd.
4	Bridge (50' x 8.5')	Signal Butte FRS & Floodway	Flood Control Project: 0.43 miles south of McKellips Blvd.
5	4-48" CMP's	existing cross-drainage	0.3 miles north of Brown Rd.
6	2-40" x 30" CMP Squash	existing cross-drainage	@ Foothill St.
7	24" RCP	existing cross-drainage	Manzanita St.
8	10' x 3' RCBC	existing cross-drainage	0.04 miles north of Greasewood St.
9	Low Water Crossing	existing cross-drainage	channel between Happy Days Park and D Ave
10	Low Water Crossing	existing cross-drainage	A Ave
11	18" CMP	existing cross-drainage	Median of Main St./ Apache Trail
12	Low Water Crossing	existing cross-drainage	0.2 miles north of US 60
13	Bridge	CAP Canal	US 60
14	2-10' x 4' RCBC's	Siphon Draw Drainage Improvements	Flood Control Project: 0.07 miles north of Pronghorn Ave.
15	10' x 3' RCBC	existing cross-drainage	0.01 miles north of Pronghorn Ave.
16	2-24" RCP's	existing cross-drainage	0.05 miles south of Pronghorn Ave.
17	2-10' x 4' RCBC's	existing cross-drainage	0.04 miles south of Mesquite St.
18	4-10' x 4' RCBC's	existing cross-drainage	0.09 miles south of Segura Ave.
19	Bridge	Powerline FRS & Floodway	Flood Control Project: 0.11 miles south of Segura Ave.
20	Low Water Crossing	existing cross-drainage	0.23 miles south of Starfire Ave.
21	36" RCP	existing cross-drainage	0.09 miles north of Ray Rd.
22	Diversion Dike	existing cross-drainage	0.46 miles south of Pecos Rd.



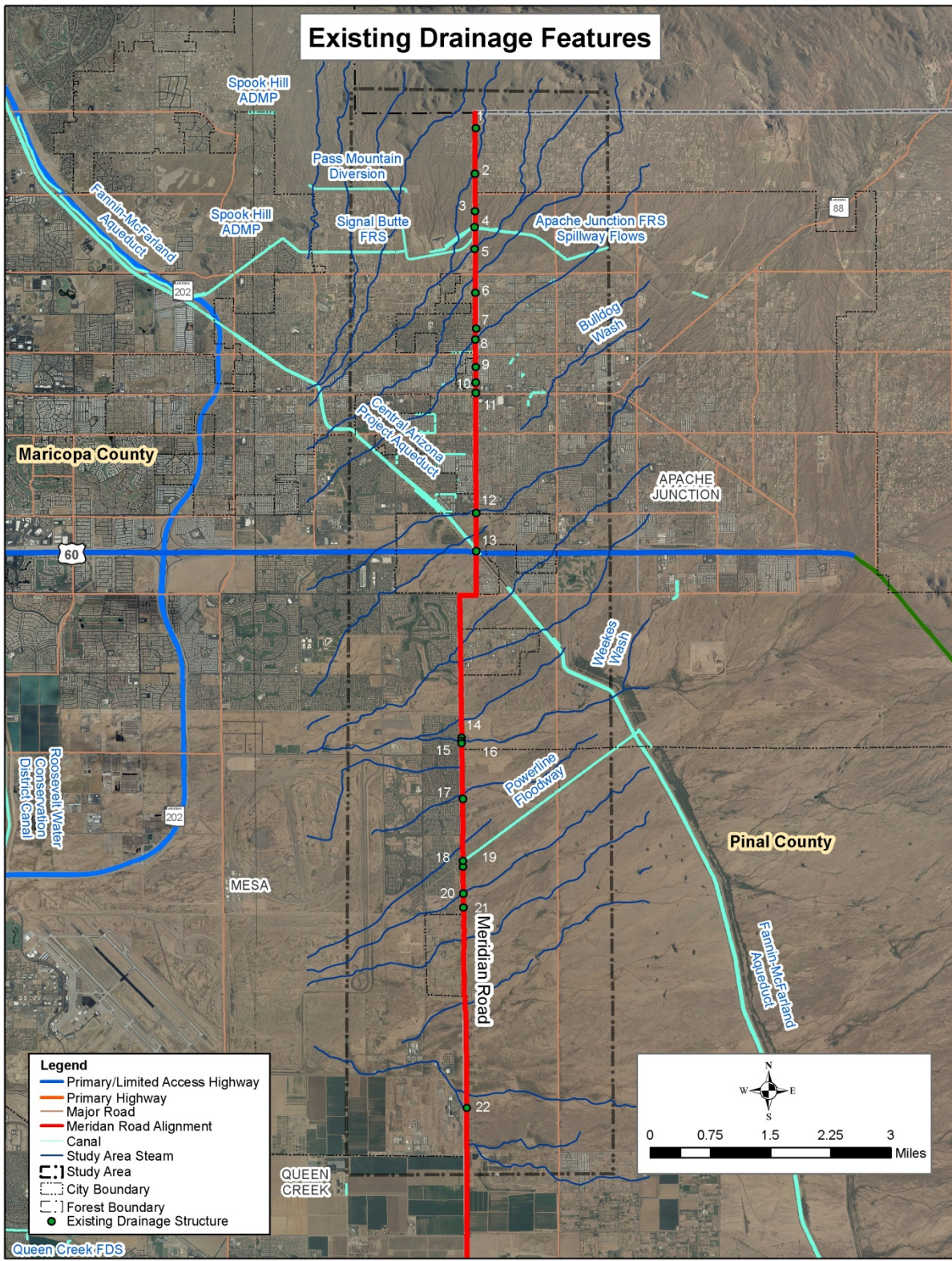

Figure 6: Existing Drainage Features

## **Area Drainage Master Plan**

The purpose of an Area Drainage Master Plan (ADMP) is to identify existing flood-prone areas as well as projections of future conditions. Several existing and proposed detention basins, cross culverts, and collector channels identified in the East Mesa ADMP directly impact the Meridian Road corridor and are summarized below:

### *Signal Butte:*

Signal Butte Flood Retarding Structure (FRS) is an earth-fill dam with a geo-membrane which is part of the Buckhorn-Mesa system. The Signal Butte FRS is 1.3 miles in length and has a height of 39 feet, with a storage capacity of 1,620-acre feet. It is situated 100 feet to the west of Meridian Road north of Brown Road/Lost Dutchman Boulevard. Any impact to the geo-membrane would be a fatal flaw for the Flood Control District. There is a maintenance road running alongside the dam which would need to be maintained at all times if Meridian Road is constructed or reconstructed. Any impact to the dam would require the involvement of Arizona Department of Water Resources (ADWP) and National Resources Conservation Service (NRCS) as well as the Flood Control District of Maricopa County.

### *Bulldog Floodway:*

Part of the Signal Butte FRS, the channel crosses Meridian Road approximately a half mile north of Brown Road/Lost Dutchman Boulevard. The flow in this channel is not supercritical which would allow for the placement of new piers if the new structure was required to carry Meridian Road over the floodway. Access to the floodway is from Meridian Road which would need to be maintained at all times during any construction or reconstruction of Meridian Road.

### *Sunland Springs Channel and Siphon Draw Detention Basin:*

The Siphon Draw Detention Basin is located east of Meridian Road in Pinal County and north of the Elliot Road alignment. The Sunland Springs Channel follows the Meridian Road alignment north of the Siphon Draw Basin. These facilities convey runoff reaching the site from two the CAP over chutes and intercept runoff at the Pinal County line (Meridian Road alignment). The Siphon Draw Detention Basin collects channelized runoff and runoff from Siphon Draw and attenuates flows to allow a reduction in the size of downstream improvements. The Sunland Springs Channel which runs along the east side of Meridian Road is a concrete lined channel with eight drop structures extending 6,800 feet north of the Siphon Draw Basin. The channel acts as a flow-by system that discharges excess flows into the basin through a side channel spillway. The Siphon Draw Basin collects the overflow from the Sunland Springs Channel and from two additional locations.

### *Powerline Floodway:*

Powerline Flood Retarding Structure (FRS) is the northern-most of a system of three flood control structures (Powerline FRS, Vineyard Road FRS and Rittenhouse FRS) running parallel to the CAP between the Baseline Road and Ocotillo Road alignments in Pinal County. Despite being located in Pinal County, the structures primarily provide flood protection for downstream portions of Maricopa County. Powerline FRS conveys storm water runoff to the Powerline Floodway which crosses Meridian Road a half mile south of Warner Road and outfalls at the East Maricopa Floodway. No structural impacts will be permitted to the Floodway. Any new bridge will require a clear span in order not to affect the



supercritical flow in the channel. The Natural Resources Conservation Service (NCRS) will need to permit any construction impacts to the Floodway.

### Utilities

Arizona Blue Stake was contacted to identify the utility stakeholders within one mile either side of the study area.

**Figure 7** illustrates the existing utilities within the study area. **Table 3** contains a list of the utility owners and utility types identified by Blue Stake within the study area.

**Table 3: Utility Stakeholders within the Meridian Road Corridor**

Utility Company	Type of Facility
Salt River Project (SRP)	Communication, Electrical, Irrigation
Century Link	Coaxial, Fiber Optic
Cox Communication	CATV, Fiber Optic
Southwest Gas	Gas
Media Com	CATV
Arizona Water Company	Water
Central Arizona Canal (CAP)	Irrigation
AT&T	Fiber Optic
City of Mesa Utilities	Gas, Water

The utility stakeholders identified by Blue Stake were contacted to determine what facilities are within in the project study area and to request mapping. The following provides descriptions of the existing utilities within the Meridian Road corridor by utility stakeholder.

*Overhead Electric:* SRP overhead electric lines exist for the majority of the alignment of Meridian Road along the east side of the right-of-way. In addition, there are 500kV overhead electric transmission lines crossing Meridian Road diagonally just south of the Powerline Floodway and between Elliot Road and Guadalupe Road. 69kV overhead electricity lines cross Meridian Road at Southern Avenue, University Drive/Superstition Boulevard and just north of Brown Road/Lost Dutchman Boulevard. Finally, a pair of 230 KV lines paralleling the 69kV line also crosses Meridian Road just north of Brown Road.

*Underground Electric:* SRP underground electric lines exist in the vicinity of the new subdivisions along Meridian Road from half mile north of Elliot Road to one mile south of Elliot Road.

*Irrigation:* The CAP canal crosses Meridian Road at the US 60 overpass.

*Potable Water:* Arizona Water Company has numerous facilities in Meridian Road from Southern Avenue north to McDowell Boulevard. The City of Mesa operates a potable water system along Meridian Road. These facilities consist of a pipeline ranging from 12 inches to 20 inches in diameter extending from half mile north of Elliot Road to Warner Road and a pipeline ranging from 12 inches to 16 inches extending from Pecos Road to Germann Road. In addition, there are two City of Mesa well sites along Meridian

Road located at the northwest corner of Germann Road and Meridian Road and at half mile south of Pecos Road on the west side of Meridian Road.

*Natural Gas:* The City of Mesa operates natural gas facilities in the corridor including a 4-inch pipeline extending in Meridian Road from Germann Road south to Queen Creek Road.

*Sanitary Sewer:* North of US 60 there are sanitary sewers located both under Meridian Road and crossing at major intersections within the study area.

*Telephone:* Both CenturyLink and Cox Communication have facilities along Meridian Road between Ocotillo Road and Lenora Road and from Rittenhouse Road to Empire Boulevard.

*Cable TV:* Cox Cable has facilities along Meridian Road in the vicinity of the new subdivisions on the west side of Meridian Road between half mile north of Elliot Road and one mile south of Elliot Road. Media Com has facilities along Meridian Road north of US 60.



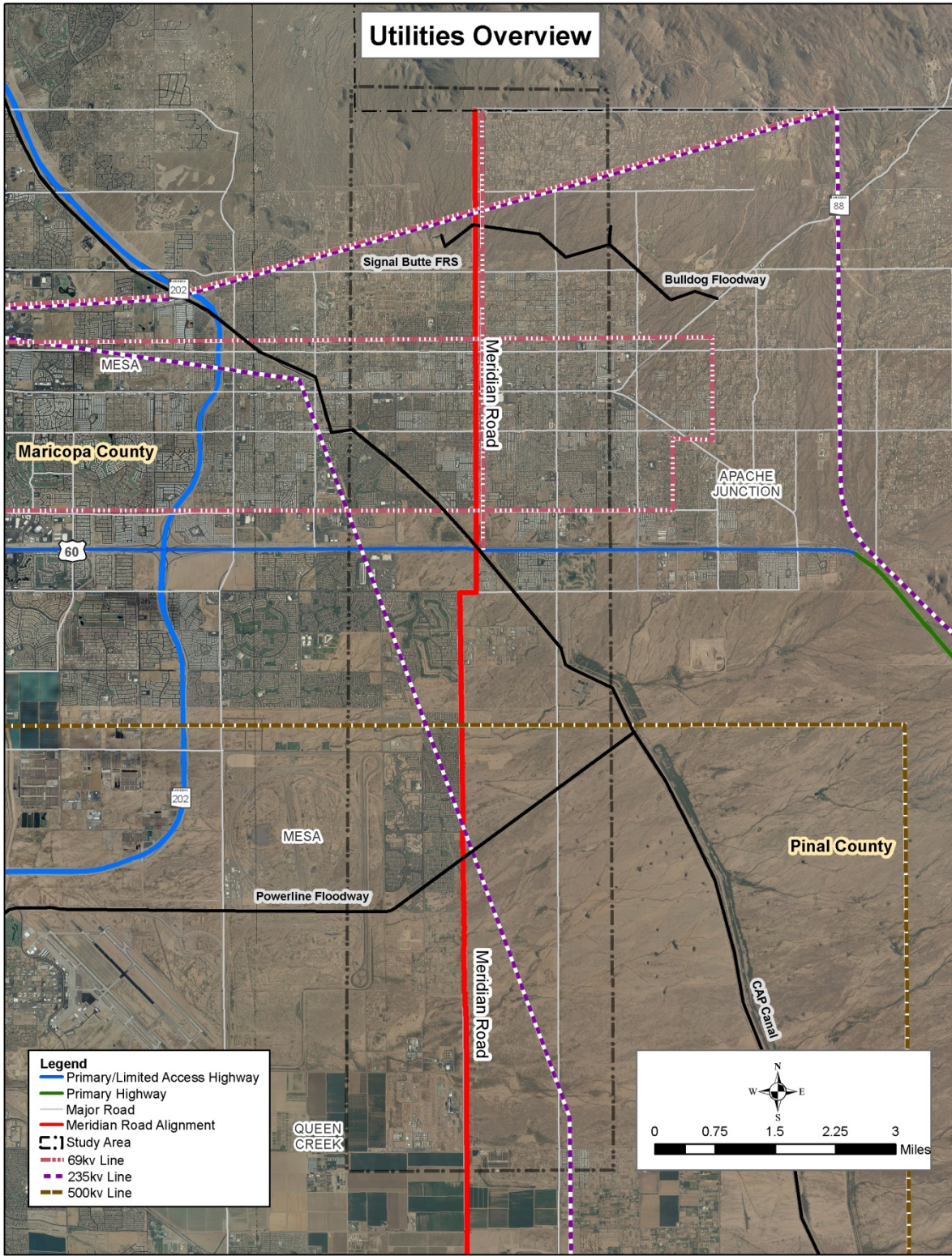

Figure 7: Existing Utilities

## Pavement

Maricopa County Department of Transportation (MCDOT) operates a Pavement Management Program which provides a systematic process to plan pavement preservation activities. The program provides, analyzes and summarizes roadway and pavement information in order to identify optimum strategies and select cost-effective pavement preservation methods. MCDOT Operations uses three categories to evaluate the roadway. The first category is the pavement condition rating (PCR) which rates the condition of the pavement by measuring the physical distresses in the pavement such as cracking and potholes. The next rating category is the international roughness index (IRI), which measures the roughness of the pavement surface. The final rating is the Sufficiency Rating. This rating is based on six different types of geometric distress which are inventoried for safety. These distresses are: lane width, shoulder width, bottlenecks, drainage, and horizontal and vertical sight distance.

The average PCR for county roads in Maricopa County is a very good rating at 82.61. The average PCR for Meridian Road from Warner Road to McDowell Boulevard is a good rating at 62.00. The average roughness of the county roads in Maricopa County is 163.09, which is rated as average. The average IRI rating for Meridian Road between Warner Road and McDowell Boulevard is 235, which is rated as very rough. A sufficiency rating number between 0 and 100 is determined for each section of road with 100 being the best. If the rating is less than 35, the roadway is programmed for re-construction. The average sufficiency rating for Meridian Road between Warner Road to McDowell Boulevard is 90. Additional information on the current pavement conditions per segment of the Meridian Road Corridor is available in *Working Paper #1: Existing and Future Conditions Inventory*.

## Existing Land Use

The following sections summarize an inventory of existing land uses within the study area. Additional information is available in *Working Paper #1: Existing and Future Conditions Inventory*.

## Jurisdictions

The study area is segmented into five separate jurisdictions (City of Apache Junction, City of Mesa, Town of Queen Creek, Pinal County and Maricopa County) that control development through their own adopted general/comprehensive plans, zoning ordinances, and subdivision regulations.

## Land Use

From McDowell Boulevard to Southern Avenue the primary land use is low to medium density residential with pockets of commercial. The residential is characterized by a number of RV parks such as El Dorado Mobile Home Resort and Coral Sand RV Park. Southern Avenue to Baseline Road land use patterns include primarily rural-residential with small parcels of commercial, industrial and low density residential. A small pocket of fabrication and heavy equipment manufacturing uses is located among other commercial and industrial operations south of Baseline Road. Further south the existing land use pattern within the study area primarily reflects the rural residential and agricultural themes that have existed in the region for decades. The eastern half of the study area is occupied largely by agricultural uses and large-lot, single-family homes such as Sunland Springs Subdivision, Bella Via and Superstition View Ranchettes. Currently undeveloped rural land platted for future development is located to the



west of Meridian Road. The residential developments located to the north typically exhibit smaller lot sizes (approximately six units to the acre) than those located to the south.

Several industrial employment areas are located in south Mesa and east Queen Creek. Specifically, the Landstar Polymer plant, located at the northwest corner of the intersection of Meridian and Pecos roads, is a rubber recycling facility currently under development that is expected to be a cornerstone of the Meridian Business Park in Mesa. Similar uses nearby include TRW Safety Systems, which manufactures automobile airbags, and the Arch Chemical semiconductor chemical manufacturing plant. **Figure 8** shows the existing land uses within the study corridor.

### Zoning

The existing zoning districts utilized by the City of Mesa, City of Apache Junction, Maricopa County and Pinal County that fall within the study area have been collapsed into five general categories to illustrate a consistent pattern of zoning among differing county and city/town designations. The majority of the planning area is primarily occupied by single-family residential, agricultural, and farming-related uses.

The majority of the northern portion of the study area from Southern Avenue to University Drive/Superstition Boulevard, is zoned for medium density single-family homes. In addition there are several isolated areas of community commercial mainly at the corners of the major arterial intersections. North of University Drive/Superstition Boulevard, the zoning changes to low density residential with large areas of park and open space notably Utery Mountain Regional Park and the Tonto National Forest. Between Southern Avenue and Baseline Road, the zoning is categorized as light industry/ Business Park.

South of Baseline Road most of the corridor has been designated as low to medium density single-family residential. Small islands of light industrial zoning exist just north of Guadalupe Road on the east side of Meridian Road and again on the west side around Pecos Road and Germann Road.

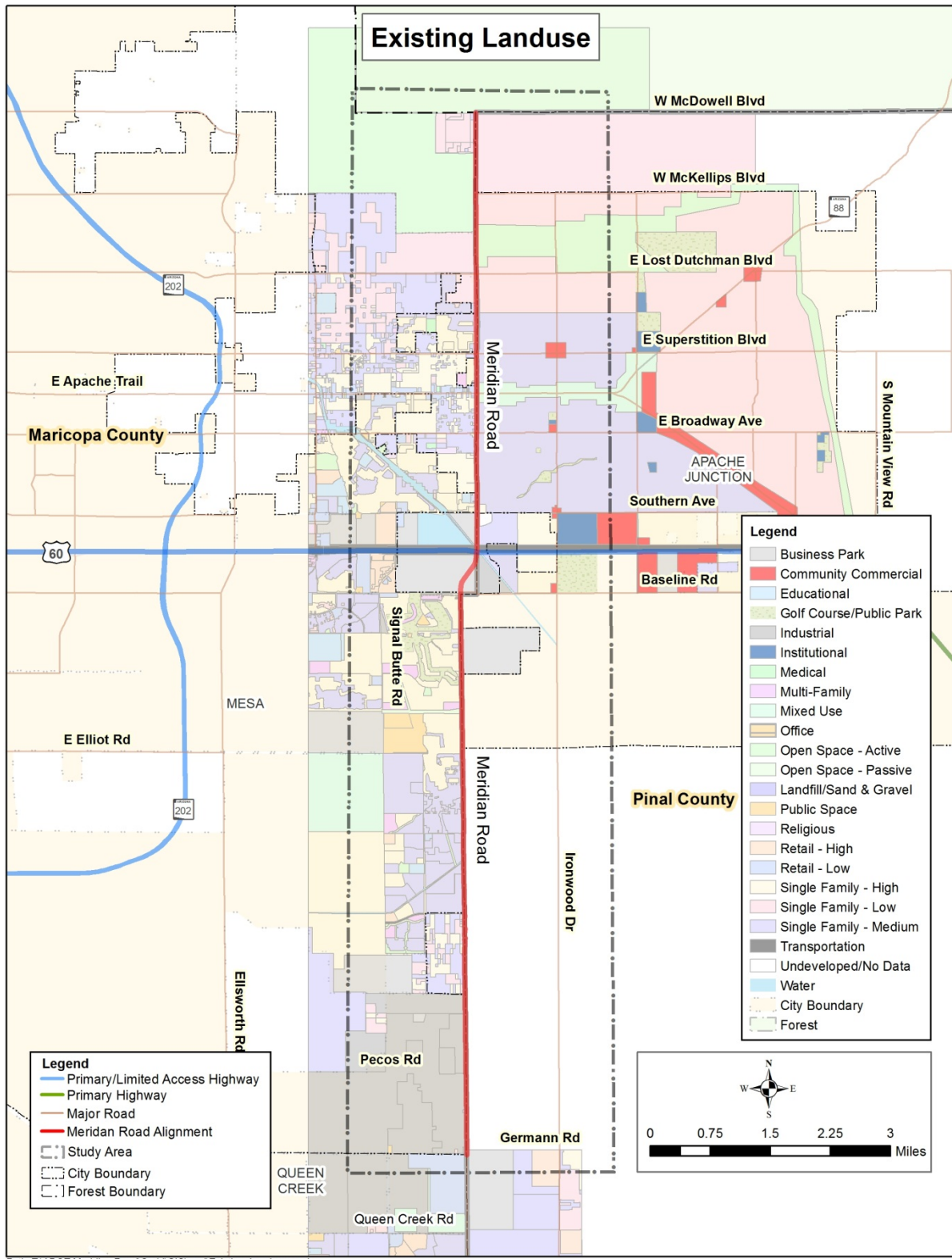

Figure 8: Existing Land Uses

## Ownership

The study area contains property within portions of unincorporated Pinal and Maricopa Counties as well as substantial land areas currently incorporated into the communities of Mesa, and Apache Junction. The City of Mesa's land occupies a majority of the western portion of the corridor. To the east, the land is occupied by the City of Apache Junction north of Elliot Road and by Unincorporated Pinal County to the south. Private entities own a majority of the land within the study area. The only exception to this trend exists on the west side of the study area bordered by Baseline Road to the south and Southern Avenue to the north. At this location, Arizona State Trust land and the Bureau of Reclamation, which operates the CAP canal, are the property owners. On the east side of the study area, in Pinal County from Baseline Road to Germann Road, nearly all of the study area is held as Arizona State Trust land in both unincorporated Pinal County and the City of Apache Junction. **Figure 9** shows the land ownership within the study area.

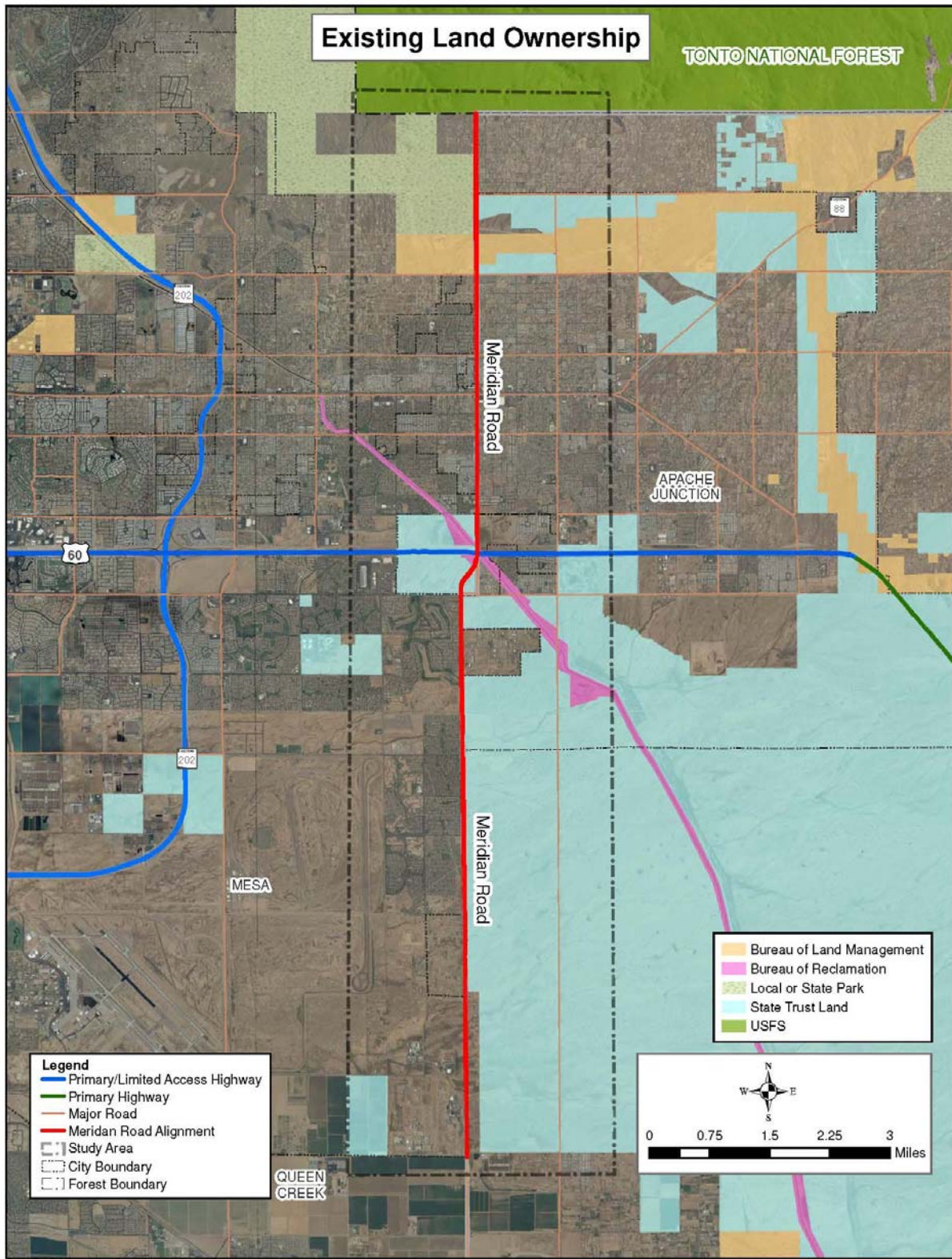

Figure 9: Existing Land Ownership



### III. Future Corridor Features

The following sections summarize an inventory of future conditions within the study area. Additional information is available in *Working Paper #1: Existing and Future Conditions Inventory*.

#### Socioeconomic

##### Planned Land Use

Located between Meridian Road and Signal Butte Road in Mesa is the Master Planned Community of Bell Via, which incorporates a mix of residential densities ranging from four to six units to the acre. The Portalis development (formerly Lost Dutchman Heights) is 7,700 acres of State Trust Land set to be developed as a master planned community. It is estimated that full build out will be 2045 with 39,000 units of future residential development and a population of 90,000 residents, 6-8 million square feet of future commercial building development and 250+/- acres of light industrial/business park development with 24,000 employees.

Superstition Vistas includes 175,000 acres of raw desert land held in trust by the Arizona State Land Department situated east of Meridian Road and extending to US 60. The area is designed as an integrated master planned community featuring housing, employment centers and interconnected transportation system. Though the region would benefit from Superstition Vistas' capacity to handle future growth, the extent of development of Superstition Vistas depends immediately on State Trust Land policy and actions and the delivery of adequate infrastructure. Without adequate transportation infrastructure the growth of Superstition Vistas will stall. Economic development is necessary for Superstition Vistas' future growth, though the degree to which this area can reach its economic development potential will depend on adequate transportation infrastructure. Depending on future growth rates the estimated population will be between 250,000 and 1 million.

##### Future Land Development

Future growth along and within the study area is expected to respond to three key development related influences. Most prominently in Mesa is the conversion of the Phoenix-Mesa Gateway Airport from a general aviation airport to a reliever commercial facility for Sky Harbor International Airport in Phoenix. This has triggered further significant commercial and residential expansion not only for the southeast valley, but northern Pinal County as well. Complementing the transition and development of this aviation facility is the construction of the SR 24 Gateway Freeway. This limited access roadway is expected to accommodate new residential growth in the southeast valley and to generate substantial commercial, office, and industrial opportunities at its intersection with primary arterial roadways in the area. General Motors (GM) operated a 5,000-acre proving ground and research facility. Closure of the proving grounds operations will lead to redevelopment and disposition of this property in various configurations that include both residential and employment opportunities. The Mesa Gateway Strategic Development Plan shows blended residential along with medium-high density residential and urban centers at strategic node points within the research facility. Furthermore, Mesa's adopted General Plan also identifies a substantial amount of land for light and general industrial development. This is in response to the expansion of services at Phoenix-Mesa Gateway Airport and reflects the anticipated employment development within this region.



On the east side of the Meridian Road corridor in Pinal County, future land uses are recommended to occur in a much more generalized manner. The Pinal County Comprehensive Plan permits both flexibility and innovation for future development. Anticipating continued annexation and subsequent development in the area near the incorporated City of Apache Junction. The goal of this area is to retain large tracts of rural parcels in single ownership so that master planned communities can be devolved in the future along with the establishment of roadways, service areas and other infrastructure improvements. This is typified by the planned region area known as Superstition Vistas, in northern Pinal County, which is expected to create additional internal and external trips within the study area.

Pinal County's Land Use Plan also shows an employment corridor between Williams Field Road and Pecos Road. A High Intensity Activity Center, Williams Gateway Freeway Activity Center, is located at Ironwood Road between Williams Field Road and Pecos Road. The Williams Gateway Freeway Activity Center includes medium and high density residential development. Build out population associated with this residential development could accommodate approximately 21,000 people. Approximately 300 acres of various employment types are also identified for planning purposes that could result in the potential for 29,000 jobs in this area. **Figure 10** shows the future land uses within the study corridor.

### Future Transportation Projects

**US 60 Traffic Interchange at Meridian Road:** An interchange is planned for Meridian Road at US 60 with construction scheduled for a start in summer 2015. Initially ADOT is proposing to construct an interim, partial interchange. The design will consist of on and off ramps to the west of Meridian Road. In the interim condition no improvements will be made to the existing structure over the US 60. The bridge will accommodate one 11 foot and one 14 foot lane in each direction along with a 5 foot sidewalk. Meridian Road will be widened to the north of US 60 to accommodate four through lanes plus two left turn lanes. Similarly to the south the road will be widened to four through lanes and will be tapered back to the existing road width as soon as possible.

A full traffic interchange to accommodate a six-lane divided Meridian Road will necessitate the construction of a new structure which will have to provide for a new 14ft clearance requirements over the CAP canal.

**US 60 Widening: Crimson Road to Meridian Road –** US 60 is planned to be widened from four lanes to six general purpose lanes and two High Occupancy Vehicle Lanes from Crimson Road to Meridian Road in Phase 3 of the MAG Regional Transportation Plan (2015-2020).

**Gateway Freeway (SR 24):** The SR 24 corridor is located in southeast Mesa and northwest Pinal County. The freeway would begin at Loop 202 near the Hawes Road interchange and extend southeasterly into Pinal County and connect to US 60 or SR 79 north of the Florence Junction. The SR 24 study area lies within or adjacent to the jurisdictional boundaries of the cities of Mesa and Apache Junction, the Towns of Queen Creek and Gilbert, and unincorporated portions of Maricopa and Pinal Counties. The section from Loop 202 to Ellsworth Road is currently under construction and is due to be completed by the end of 2014. Additional phases beyond Ellsworth Road have been dropped from MAG Regional Transportation Plan until the North-South Corridor Study in Pinal County advances. The proposed route

crosses Meridian Road ½ mile south of Williams Field Road with a full grade separated traffic interchange.

North-South Corridor: The North-South Corridor (US 60 to I-10) is planned to extend 45 miles in the north-south direction along an alignment east of Meridian Road in Pinal County. The concept is to provide a controlled access facility between US 60 in Apache Junction and I-10 near Eloy and Picacho. A current study by ADOT is underway to identify a preferred corridor.

Passenger Rail: The Passenger Rail Corridor Study is looking at both high speed and commuter rail services between Phoenix and Tucson. Currently there are a number of alternatives being analyzed which will provide the back bone for a transit service along the 'Sun Corridor'. One potential route crosses Meridian Road adjacent to the proposed SR 24 heading east to make use of transit corridors identified in the Superstition Vistas strategic plan.

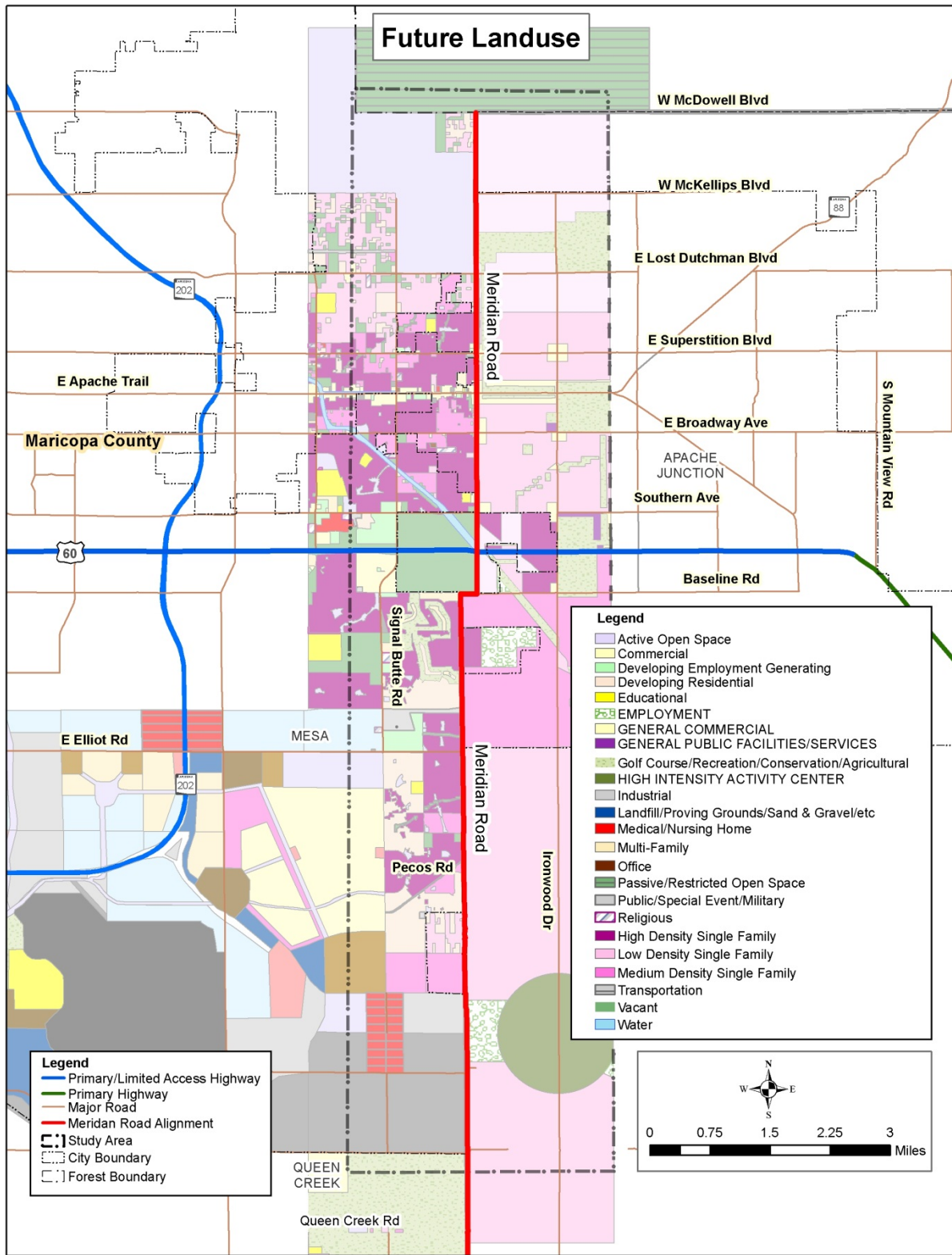

Figure 10: Future Land Uses

**Population and Employment**

In 2010, the total residential population within the boundaries of the project influence area includes nearly 210,000 people within the three municipalities of Mesa, Apache Junction and Queen Creek and the two counties of Pinal and Maricopa that encompass the area. The area of influence is generally bounded by McDowell Boulevard to the north, Germann Road to the south, US 60 to the east, and SR 202L to the west. By the year 2031, the resident population in the influence area is expected to grow more than 250 percent, reaching nearly 583,000 residents. The most dramatic population gain among the jurisdictions and the counties is expected to occur in Pinal County. The majority of this area is currently owned by the Arizona State Land Department, and includes Portalis and Superstition Vistas master planned communities. The future development of these communities will trigger a population jump from approximately 34,300 in 2010 to nearly 240,000 in 2031. Significant population increases in Apache Junction, Mesa, Pinal County and Queen Creek are also reflected in **Table 4**.

**Table 4: Project Influence Area Population Projections**

MPA	Total Population Observed in 2010 Census	Total Population Projected for 2010	Total Population Projected for 2025	Total Population Projected for 2031
Apache Junction	42,570	75,186	134,424	151,419
Mesa	137,170	128,639	163,436	171,912
Pinal County	14,243	34,339	181,212	223,632
Queen Creek	13,233	15,611	32,052	36,322
<b>TOTAL</b>	<b>207,216</b>	<b>253,775</b>	<b>511,124</b>	<b>583,285</b>

Job growth in the area of influence is also expected to rise through the year 2031 and will generally follow the pattern of growth for residential population. Nearly 43,700 jobs currently exist within the project influence area, a majority of which are contained in the industrial and commercial core of southeast Mesa. However, as the Phoenix-Mesa Gateway Airport and SR 24 Gateway Freeway corridor continues to develop, future jobs will locate on the eastern portion of the corridor as well. Pinal County, which is estimated to produce the greatest rise in resident population, will also exhibit the greatest gain in job growth. Currently, approximately 2,800 jobs exist in Pinal County. The county only captured six percent of the total jobs located within the entire project influence area. In 2031, the approximate 24,500 jobs expected to exist in Pinal County will account for 12.5 percent of the total study area employment. Queen Creek, Mesa, and Apache Junction are all expected to experience significant employment gains.

**IV. Traffic Analysis Summary**

This section provides a summary of the traffic analysis results under existing conditions (2012) and for 2025 and 2035 design years for the Meridian Road Corridor study area. The traffic results of the traffic analysis were used to develop recommendations for the Meridian Road Corridor to accommodate future traffic growth. Additional information is available in *Working Paper #1: Existing and Future Conditions Inventory* and *Working Paper #2: Evaluation Criteria and Plan for Improvements*.

**Traffic Analysis Methodology**

The ability of a transportation system to transmit the transportation demand is characterized as its level of service (LOS). LOS is a rating system from “A”, representing the best operation, to “F”, representing the worst operation. The appropriate reference for LOS operation is the *Highway Capacity Manual*, published by the Transportation Research Board. In general, LOS A and B represent no congestion, LOS C and D represent moderate congestion, and LOS E and F represent severe congestion. The MCDOT Roadway Design Manual (revised 2011) establishes LOS C as the desired criteria for rural principal arterial roadways and LOS D as the desired criteria for urban principal arterial roadways. The City of Mesa Transportation Plan and City of Apache Junction Small Area Transportation Study establishes LOS D as the desired criteria for principal arterial roadways. Because Meridian Road is likely to ultimately be a principal arterial under the jurisdiction of the City of Mesa and the City of Apache Junction, LOS D was used as the desired LOS for existing and future traffic operations within the corridor.

LOS can be calculated for roadway segments, intersections, and freeway mainline lanes and ramps. LOS estimates also can be calculated for different periods, including daily conditions and peak hour conditions. The LOS analysis discussed in the following sections focuses on planning level roadway segment performance within the study area based on daily roadway segment volumes and analysis of study area intersections based on peak hour turning movement volumes and anticipated delay.

The widely accepted *2009 Quality/Level of Service Handbook* published by the Florida Department of Transportation is the planning guidelines relating LOS to daily volumes to estimate capacity for roadway segments. These guidelines are not an exact description of the actual operating LOS on a particular roadway segment, but they give an indication of when the roadway falls below acceptable levels of service.

The *Highway Capacity Manual* considers the average delay per vehicle as the measure to determine the LOS of a signalized intersection. The delay and LOS are calculated for the intersection, each approach, and each turning movement. **Table 5** lists the LOS criteria for signalized intersections as stated in the *Highway Capacity Manual*. **Table 6** the level-of-service criteria for the unsignalized study area intersections. The LOS for the study area intersections was evaluated using *Synchro* software, which also utilizes the criteria described in **Table 5** and **Table 6**.

**Table 5: Level of Service Criteria: Signalized Intersections**

Level-of-Service	Average Control Delay (s/veh)
A	≤ 10
B	> 10-20
C	> 20-35
D	> 35-55
E	> 55-80
F	> 80

**Table 6: Level of Service Criteria: Unsignalized Intersection**

Level-of-Service	Average Control Delay (s/veh)
A	≤ 10
B	> 10-15
C	> 15-25
D	> 25-35
E	> 35-50
F	> 50

## Existing 2012 Traffic Volumes

Traffic Research and Analysis collected 48 hour approach and departure volumes at nine locations along Meridian Road and counted current AM and PM peak period traffic volumes at ten existing intersections within the study area in May 2012. A seasonal adjustment factor of 20% was applied to the approach and departure volumes as well as the turning movement volumes. The seasonal adjustment factor was determined based upon ADOT's monthly ADT volumes collected within the study area. In the Apache Junction area the month in which the traffic volumes peak is 20% higher than traffic volumes in the month of May. The 2012 adjusted ADT volumes are shown in **Table 7** and illustrated in **Figure 11**. The 2012 adjusted turning movement counts for the AM and PM peak periods are shown in **Figure 12**. A detailed report of the traffic counts is contained in *Working Paper #1: Existing and Future Conditions Inventory*.

**Table 7: 2012 Average Daily Traffic Volumes**

Meridian Road Segment	Direction	Average Daily Traffic (VPD) 2012*
McDowell Road to McKellips Boulevard	NB	612
	SB	655
McKellips Boulevard to Brown Road/Lost Dutchman Boulevard	NB	1,534
	SB	1,632
Brown Road/Lost Dutchman Boulevard to University Drive/Superstition Boulevard	NB	2,707
	SB	2,914
University Drive/Superstitions Boulevard to Apache Trail	NB	3,494
	SB	3,352
Apache Trail to Broadway Road	NB	3,350
	SB	3,673
Broadway Road to Southern Avenue	NB	2,633
	SB	2,467
Southern Avenue to US 60	NB	2,633
	SB	2,467
US 60 to Baseline Road	NB	1,570
	SB	1,495
Guadalupe Road to Elliot Road	NB	731
	SB	697
Elliot Road to Warner Road	NB	781
	SB	713

\*Approach and Departure volumes are adjusted to account for a 20% seasonal factor

NB – Northbound

SB - Southbound



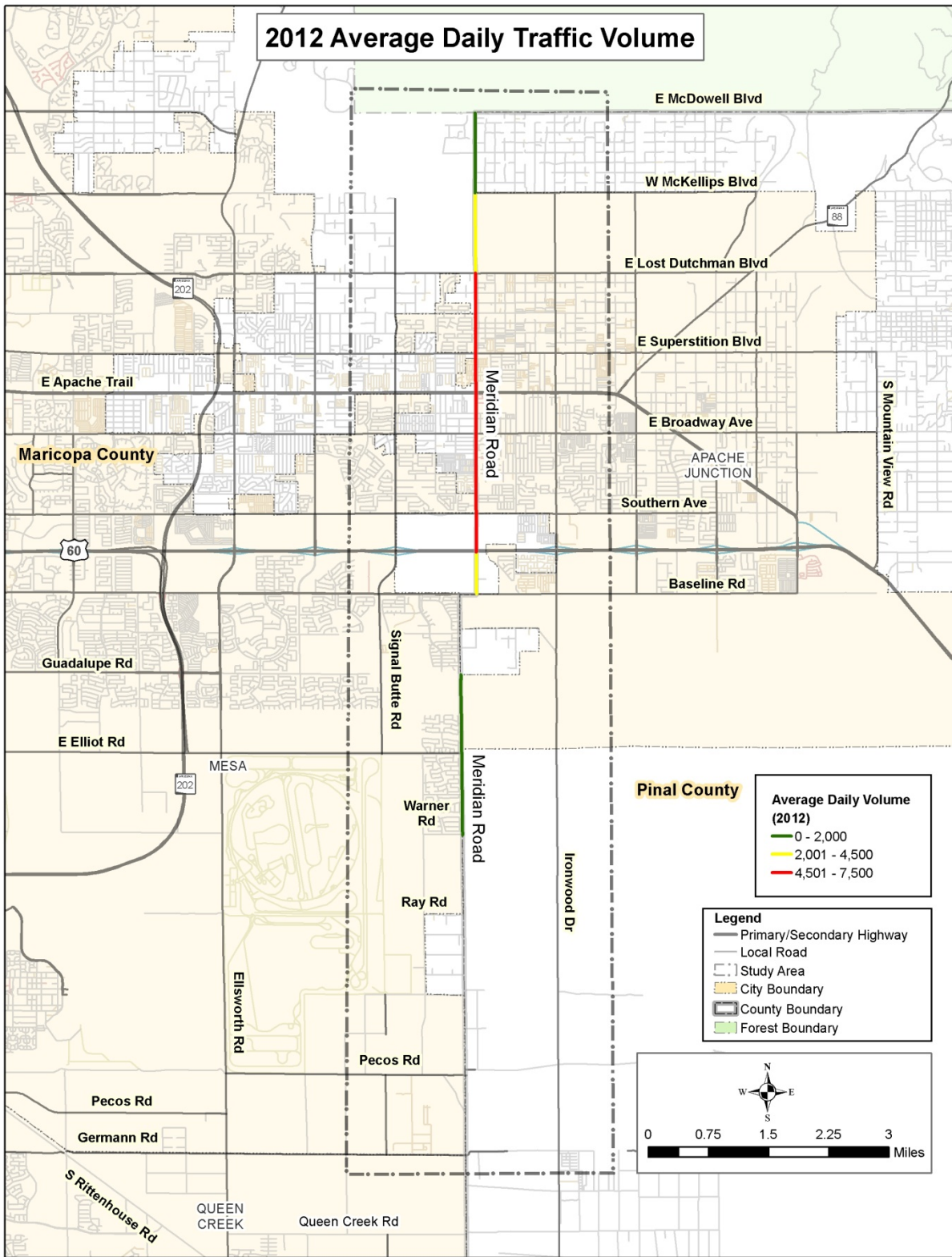

Figure 11: Existing 2012 Average Daily Traffic Volumes



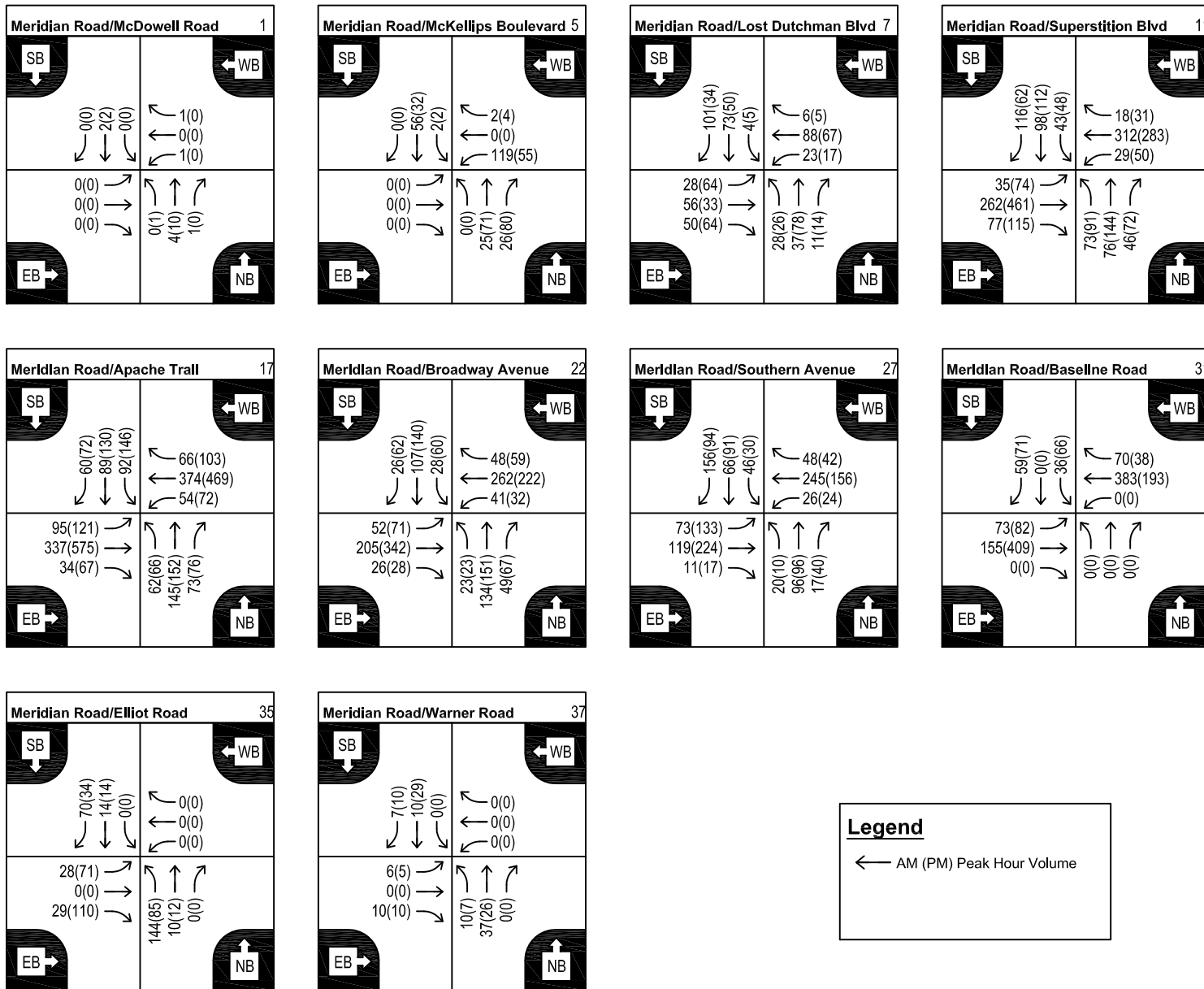

Figure 12  
Existing 2012 Turning Movement Volumes

## Existing Level of Service

### Existing Roadway Segment Level of Service

The existing number of lanes shown in the section of this report titled *Existing Network and Classification* in **Figure 2** were used to determine the LOS as well as the criteria discussed in the section of this report titled *Traffic Analysis Methodology*. The LOS thresholds for the various facility types were derived from the Florida Department of Transportation’s (FDOT) “Table 4-1, Generalized Annual Average Daily Volumes for Florida’s Urbanized Areas (Freeway & State Two-Way Arterial Facilities)”. **Table 8** shows the Average Daily Traffic (ADT) capacity threshold values by facility type calculated for LOS A/B, C and D. These threshold values were used to determine the existing roadway segment LOS for this study. **Figure 13** depicts the existing LOS for segments of Meridian Road within the Study Area.

**Table 8: Annual Average Daily Volume Threshold Values for Varies Facility Types**

Number of Through Lanes	Median	Level of Service Threshold		
		A/B	C	D
2	Undivided	9,600	15,400	16,500
3	Divided/Two-way Left-turn Lane	10,080*	16,200*	17,300*
4	Divided	29,300	35,500	36,700
5	Two-way Left-turn Lane	37,100**	44,600**	46,000**
6	Divided	45,000	53,700	55,300

\*Daily volume threshold for a three-lane facility was calculated by adjusting the daily volume threshold for a two-lane facility by 5% to account for a center lane or exclusive left-turn lane.

\*\*Daily volume threshold for a five-lane facility has been adjusted based on the lane capacity of a four-lane facility.

### Existing Intersection Level of Service

The LOS for the study area intersections was evaluated utilizing the criteria discussed in the section of this report titled *Traffic Analysis Methodology* and the existing intersection geometry for the study area intersections shown in **Figure 4**. The existing LOS for the signalized and unsignalized intersections within the study area is shown in **Figure 14**. *Working Paper #1: Existing and Future Conditions Inventory* provides the complete results of the existing 2012 LOS analysis.

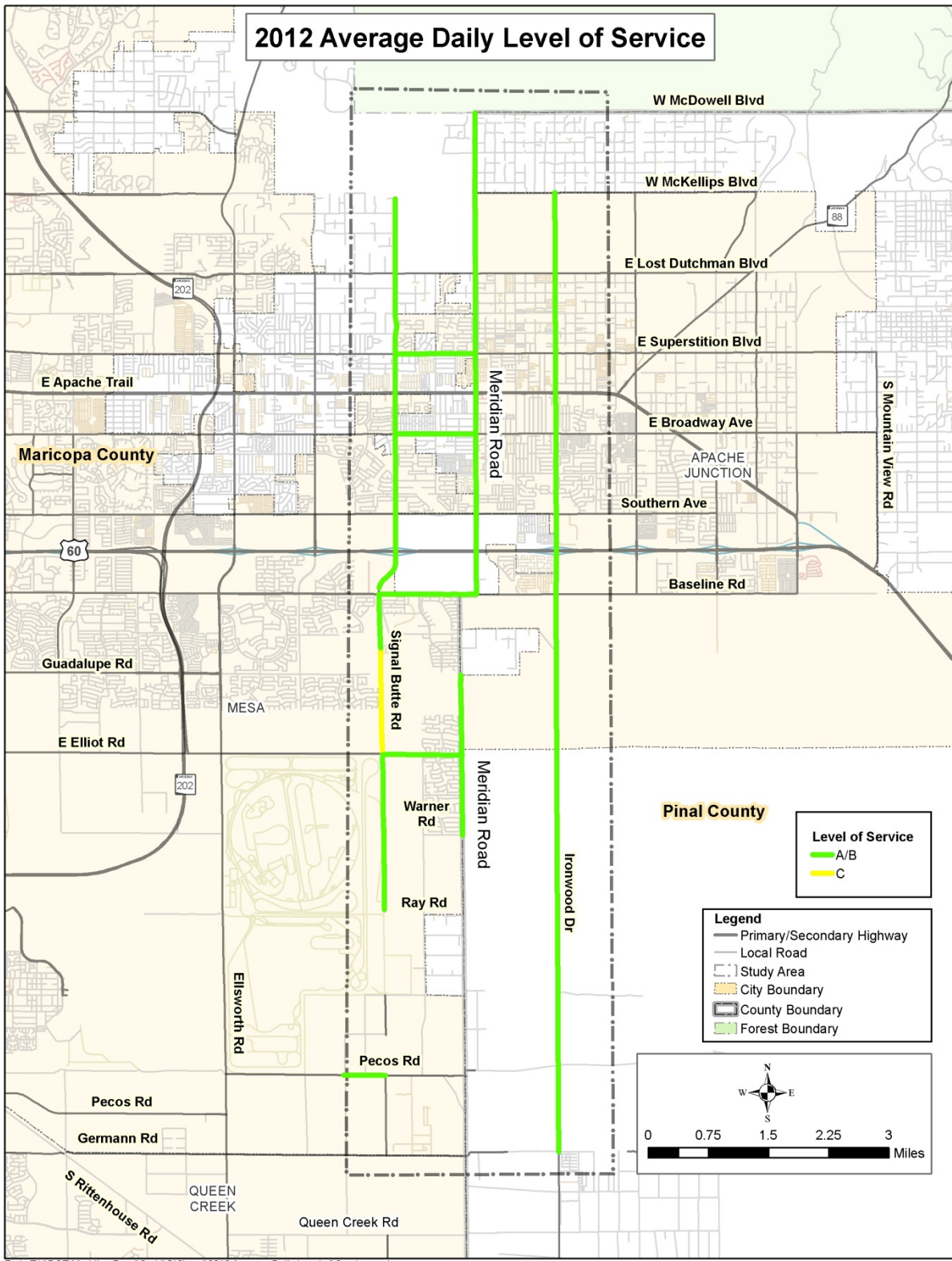

Figure 13: 2012 Average Daily Level of Service

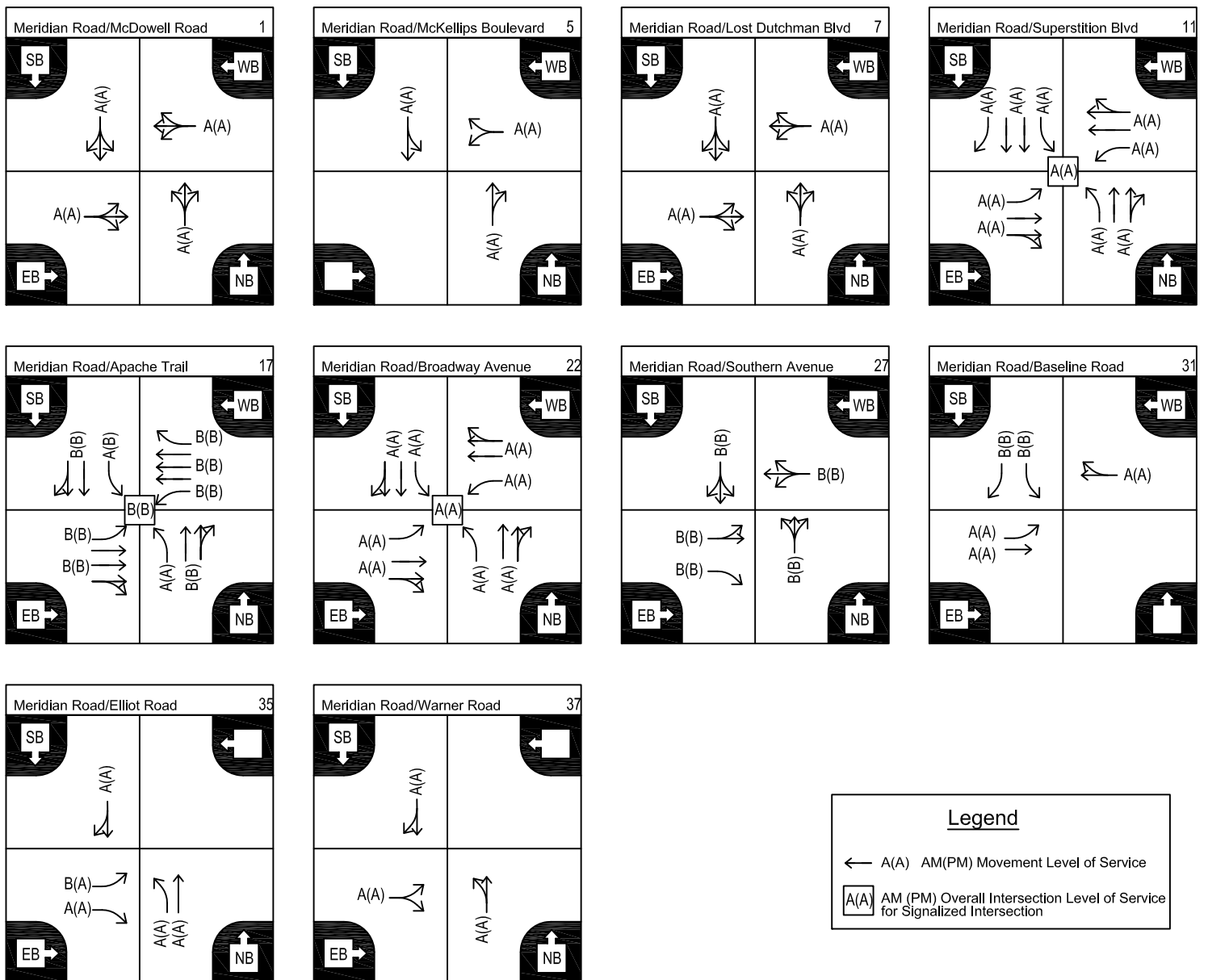

Figure 14  
Existing 2012 Intersection Level of Service



## Future Traffic Volumes

Characteristics of the future transportation network were developed after reviewing relevant plans and studies listed in the section of this report titled *Summary of Existing Plans and Studies*. The specific studies used to determine practical 2025 and 2035 traffic volumes were the *MCDOT Meridian Road Access Control and Corridor Improvement Study* and the *Apache Junction Comprehensive Transportation Study*. MAG's 2025 and 2035 travel demand forecasts were also reviewed to determine 2025 and 2035 future traffic volumes.

After review of the *MCDOT Meridian Road Access Control and Corridor Improvement Study* it was determined that the roadway network south of the US 60 was not consistent with more current plans and studies. 2025 and 2035 traffic volumes on the major streets crossing Meridian Road were significantly different between the MCDOT study and the MAG models. These differences are likely due to the planned changes in roadway network since the MCDOT study was completed. Therefore the MAG models for 2025 and 2035 traffic volumes were used for this study for traffic volumes south of the US 60.

After review of the MAG 2025 travel demand model north of the US 60, it was noted that the traffic volumes decreased from 2025 to 2035 and did not show good agreement with the traffic volume in the *Apache Junction Comprehensive Transportation Study*. Between the MAG 2025 model and the MAG 2035 model, two miles of McKellips Boulevard between Meridian Road and Crimson Road was opened thus changing the dynamics of the traffic flow in that area. Under the MAG 2025 model roadway network, traffic heading from the northwest and desiring to go to the southeast (or vice versa) is forced onto Brown Road/Lost Dutchman Boulevard due to McKellips Boulevard not extending west past Meridian Road. After review of the relevant studies and plans collected, it did not appear that McKellips Boulevard will extend west of Meridian Road; therefore, the traffic volumes from the *Apache Junction Comprehensive Transportation Study* were utilized for this study north of US 60. This information led to the development of the assumed future year 2025 and 2035 roadway network and the 2025 and 2035 daily traffic volumes shown in **Table 9** and graphically in **Figure 15** and **Figure 16**, respectively. Turning movement volume forecasts are shown in **Figure 17** and **Figure 18**, respectively for 2025 and 2035.

**Table 9: 2025 and 2035 Daily Traffic Volumes**

Meridian Road Segment	Direction	2025 ADT	2035 ADT
McDowell Boulevard to McKellips Boulevard	NB	0-5,000*	0-5,000*
	SB		
McKellips Boulevard to Brown Road/Lost Dutchman Boulevard	NB	0-5,000*	0-5,000*
	SB		
Brown Road/Lost Dutchman Boulevard to University Drive/Superstition Boulevard	NB	0-5,000*	5,001-10,000*
	SB		
University Drive/Superstition Boulevard to Apache Trail	NB	5,001-10,000*	10,001-20,000*
	SB		
Apache Trail to Broadway Road	NB	5,001-10,000*	10,001-20,000*
	SB		
Broadway Road to Southern Avenue	NB	5,001-10,000*	10,001-20,000*
	SB		
Southern Avenue to US 60	NB	10,001-20,000*	20,001-30,000*
	SB		
US 60 to Baseline Road	NB	14,315	14,761
	SB	14,709	15,129
Baseline Road to Guadalupe Road	NB	12,087	12,445
	SB	12,070	12,434
Guadalupe Road to Elliot Road	NB	6,664	5,878
	SB	6,618	5,994
Elliot Road to Warner Road	NB	14,945	13,251
	SB	14,621	13,376
Warner Road to Ray Road	NB	9,647	8,312
	SB	8,666	8,339
Ray Road to Williams Field Road	NB	8,835	9,355
	SB	7,775	9,473
Williams Field Road to SR 24	NB	12,846	4,413
	SB	12,516	5,347
SR 24 to Pecos Road	NB	10,556	15,484
	SB	10,226	16,181
Pecos Road to Germann Road	NB	6,516	10,751
	SB	6,076	11,586

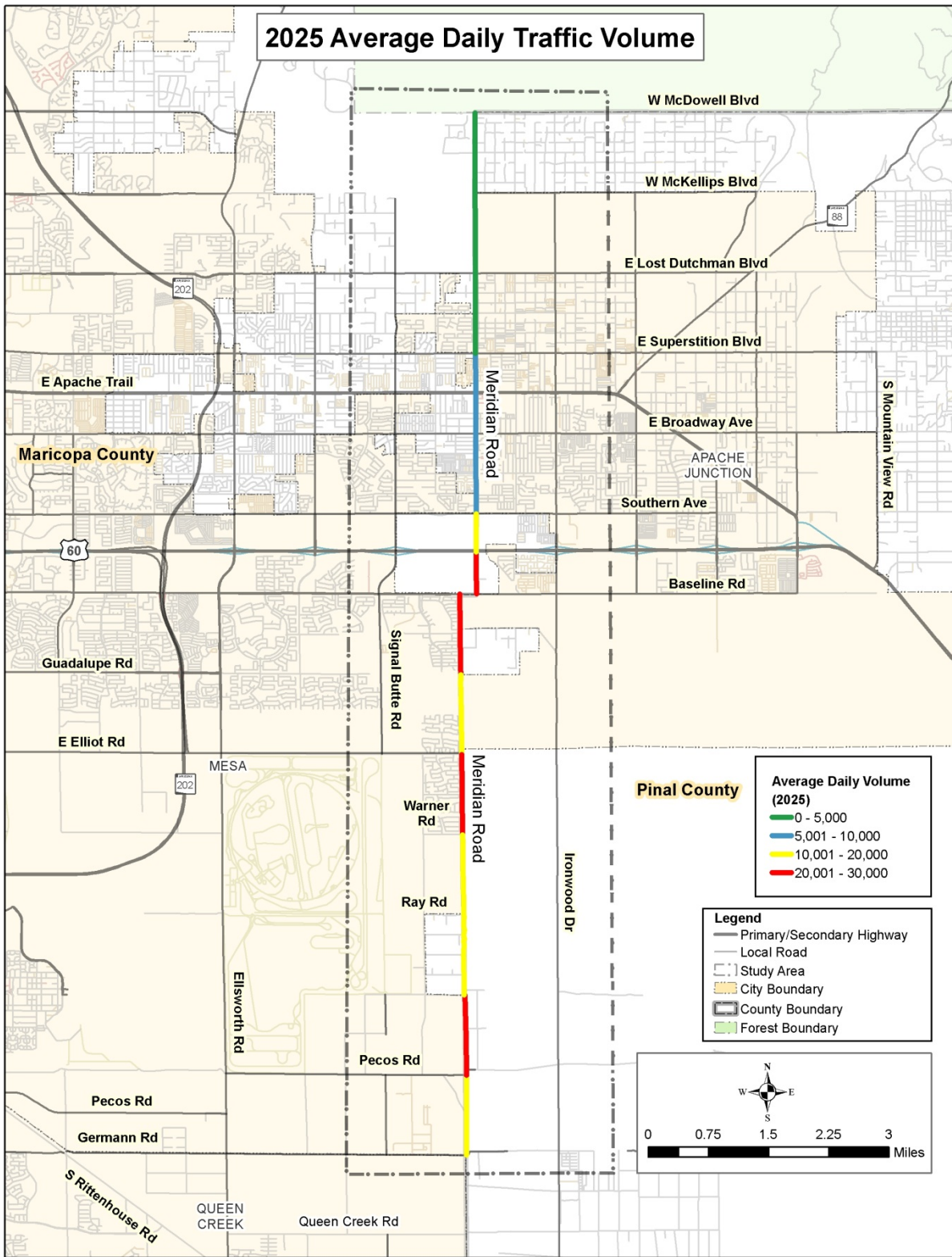

Figure 15: Future 2025 Daily Traffic Volumes

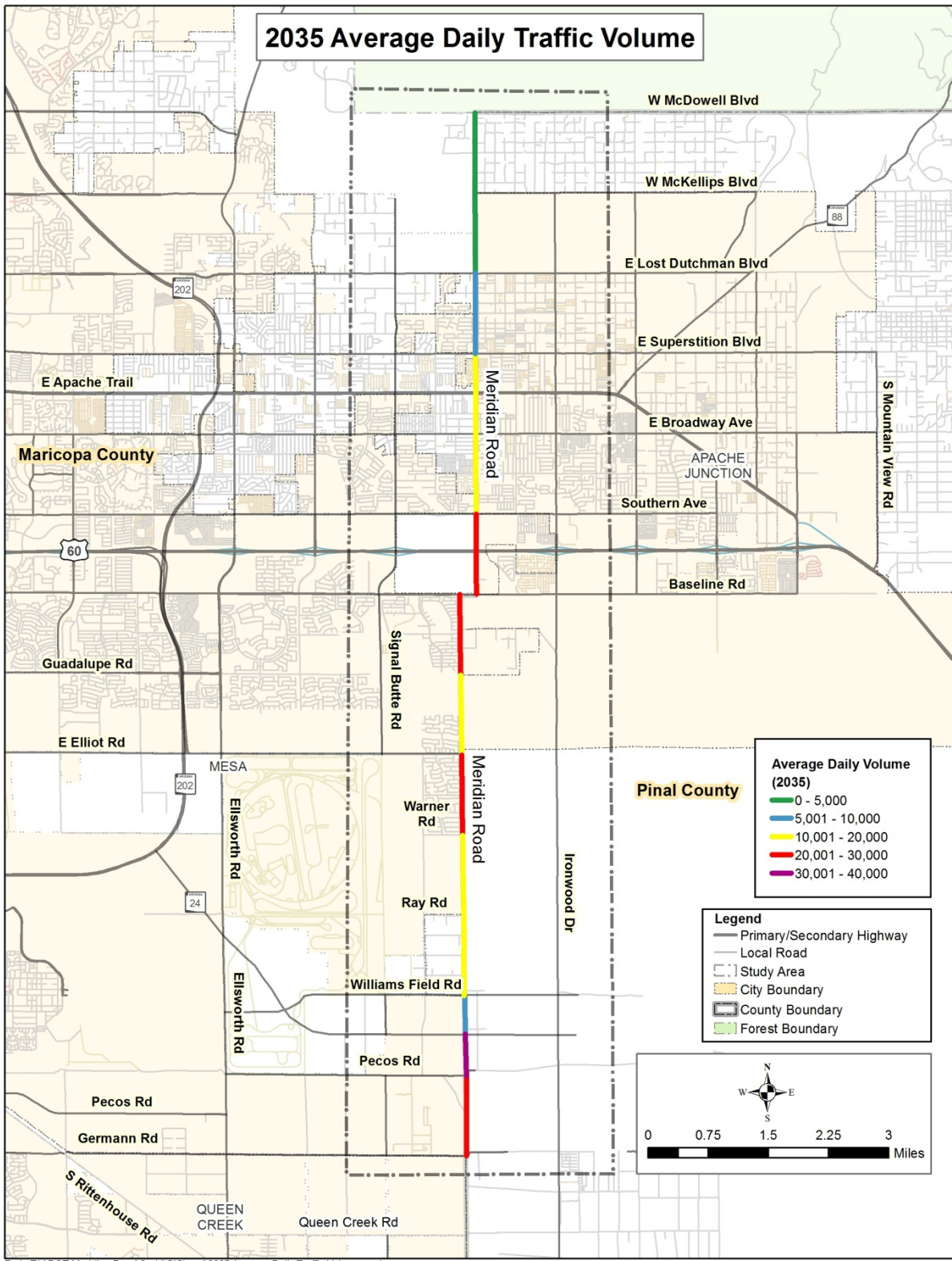

Figure 16: Future 2035 Daily Traffic Volumes



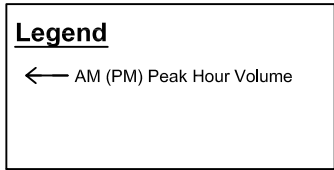
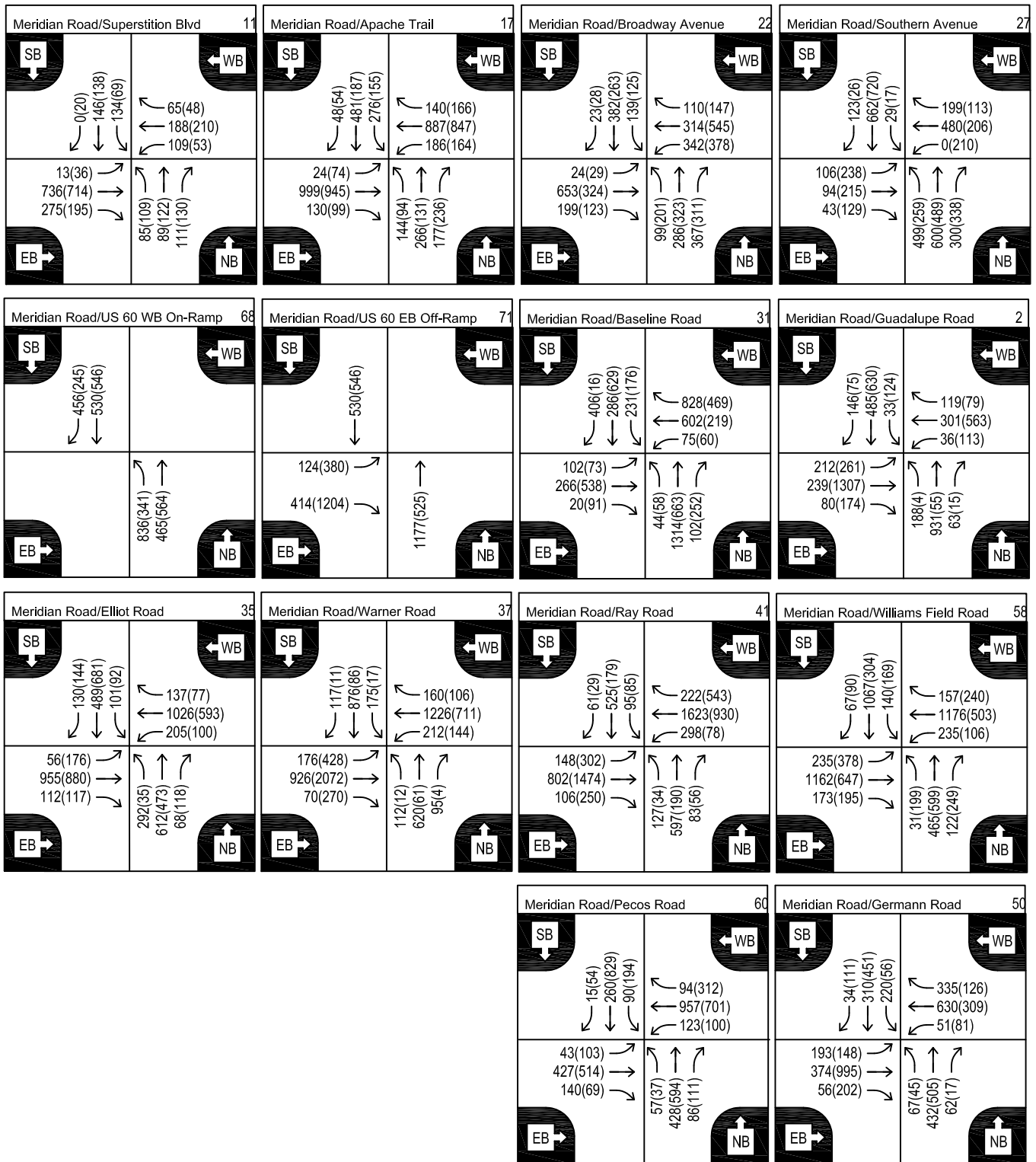
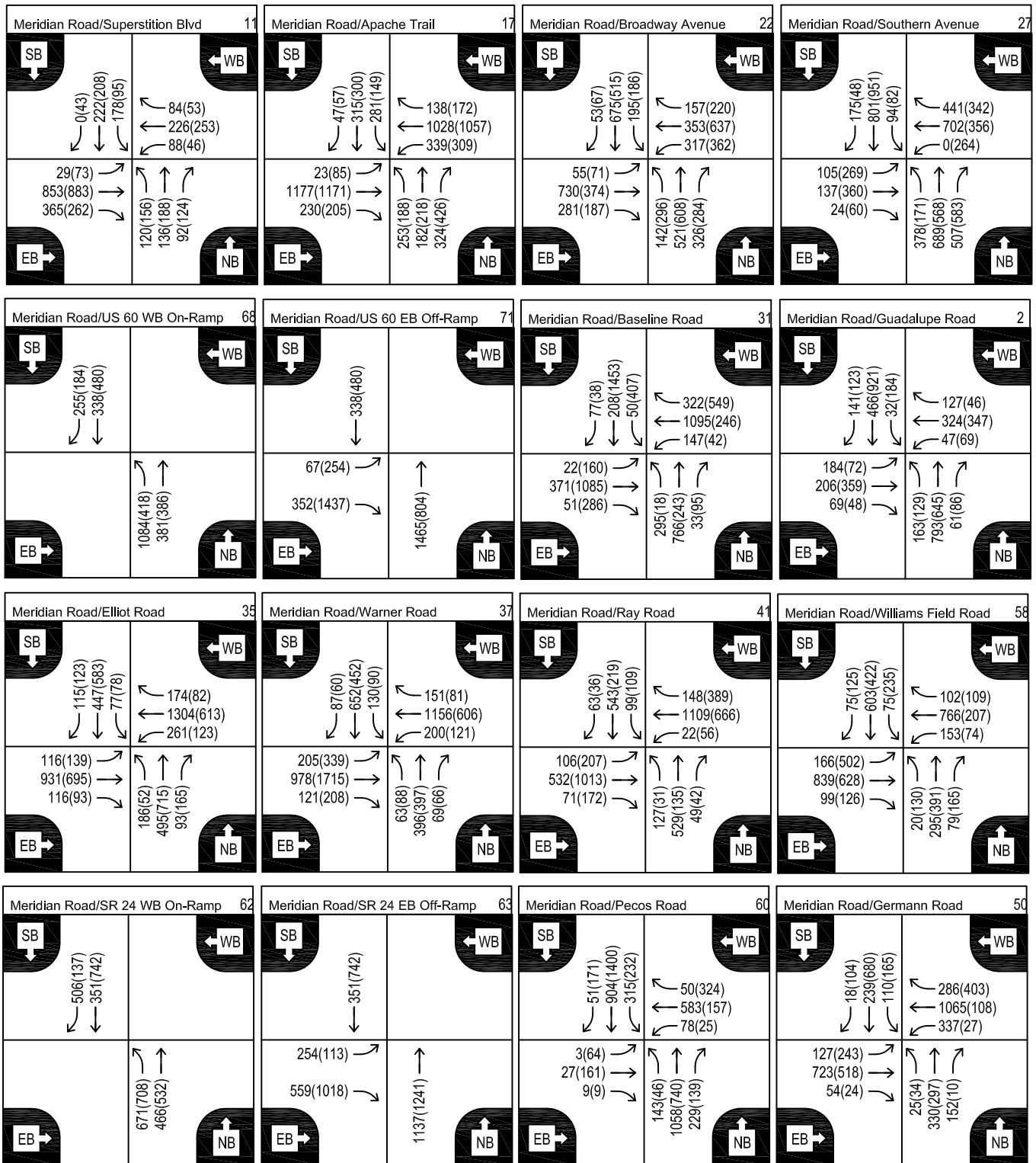

Figure 17  
Future 2025 Turning Movement Volumes



**Legend**  
 ← AM (PM) Peak Hour Volume

Figure 18  
 Future 2035 Turning Movement Volumes

## Future Level of Service

### Future Roadway Segment Level of Service

The number of lanes depicted in the Maricopa Association of Governments (MAG) models introduced in *Working Paper #1: Existing and Future Conditions Inventory* were used to determine the LOS. MAG indicated a three-lane section for Meridian Road in 2025 and 2035 within the study area. The LOS thresholds for a two-lane undivided roadway, as shown in FDOT's "Table 4-1, Generalized Annual Average Daily Volumes for Florida's Urbanized Areas (Freeway & State Two-Way Arterial Facilities)," were adjusted by 5% to account for a center lane or exclusive left-turn lanes.

**Table 10** shows the Average Daily Traffic (ADT) capacity threshold values by facility type calculated for LOS A/B, C and D. These threshold values were used to determine the roadway segment LOS for 2025 and 2035 for this study. **Figure 19** and **Figure 20** depict the 2025 and 2035 LOS for segments of Meridian Road within the Study Area, respectively.

**Table 10: Annual Average Daily Volume Threshold Values for Varies Facility Types**

Number of Through Lanes	Median	Level of Service Threshold		
		A/B	C	D
2	Undivided	9,600	15,400	16,500
3	Divided/Two-way Left-turn Lane	10,080*	16170*	17,325*
4	Divided	29,300	35,500	36,700

\*Daily volume threshold for a three-lane facility was calculated by adjusting the daily volume threshold for a two-lane facility by 5% to account for a center lane or exclusive left-turn lane.

As indicated in the section of this report titled *Traffic Analysis Methodology*, LOS D is considered the threshold of acceptable operations for Meridian Road. The LOS threshold measures reflect the traffic volume characteristics of each facility or grouping of facility types. The selection of these LOS threshold values accounts for the expectations of the drivers as well as the relative costs associated with the construction of each facility type. ADT volumes in excess of the LOS D thresholds illustrated in **Table 10** indicate a condition in which the volumes on a given roadway segment exceeds the planning-level capacity for that facility.

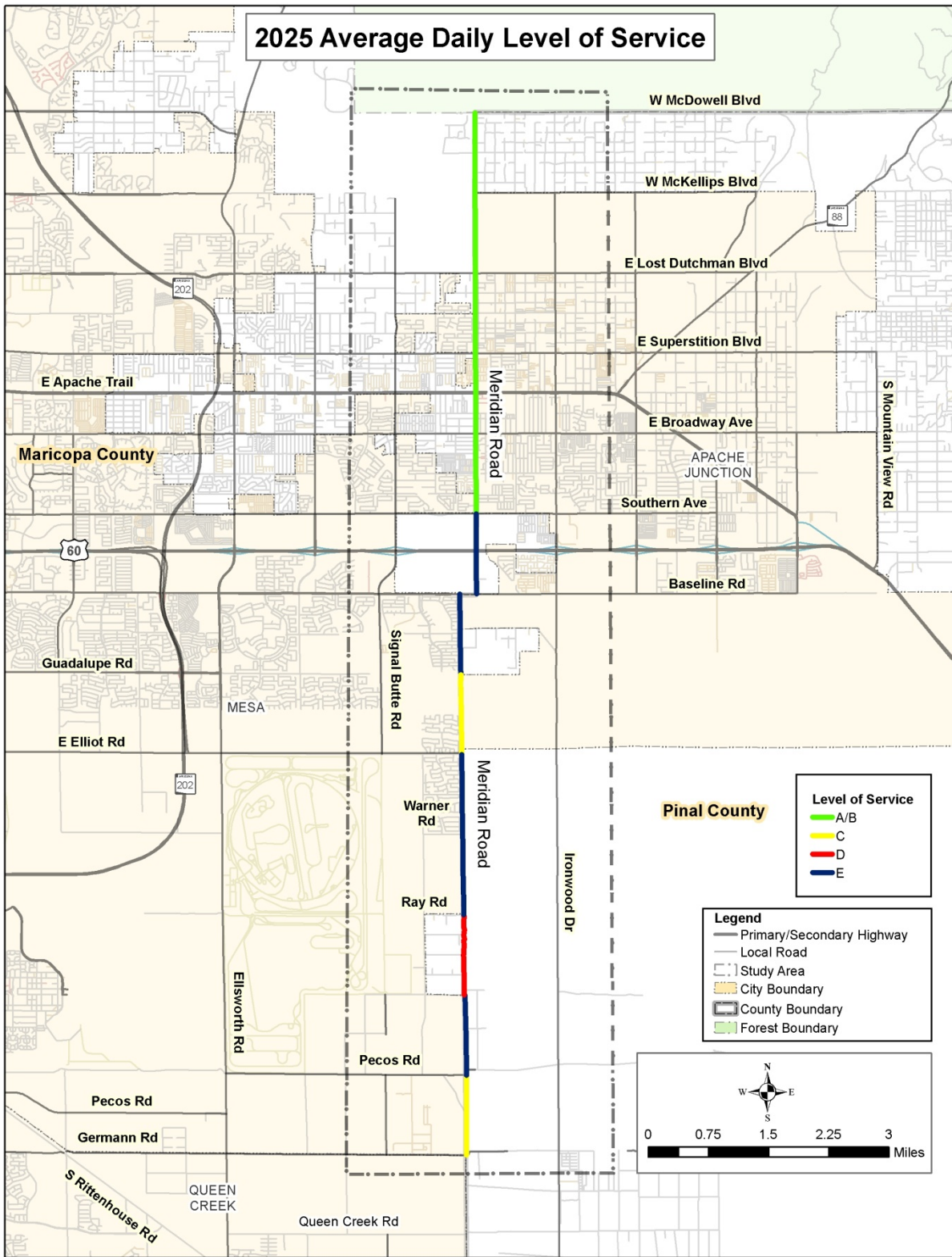

Figure 19: 2025 Average Daily Level of Service



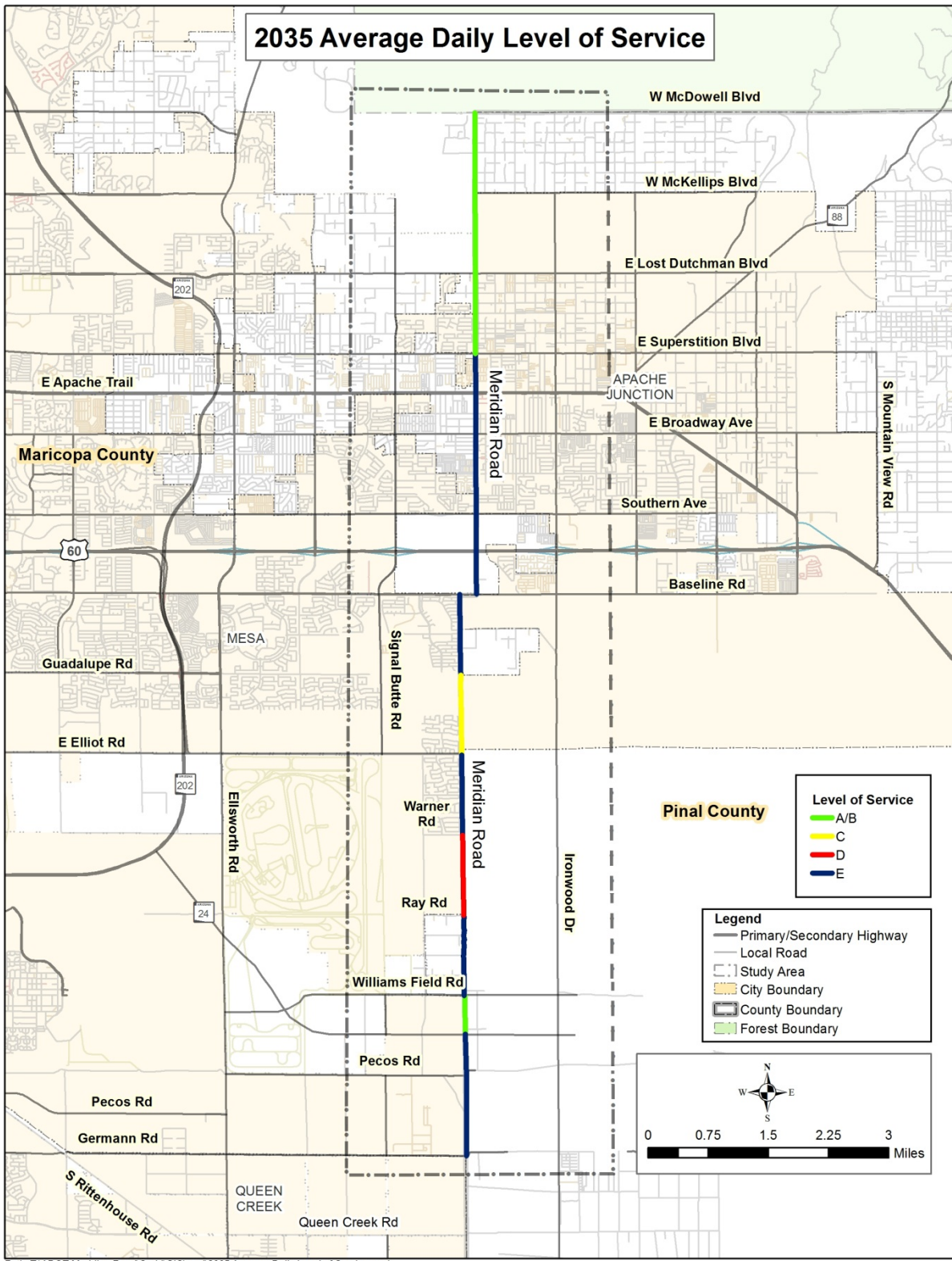

Figure 20: 2035 Average Daily Level of Service

### Future Intersection Level of Service

2025 and 2035 turning movement volumes developed in the section of this report titled *Future Traffic Volumes* and the criteria discussed in the section of this report titled *Traffic Analysis Methodology* were used to calculate the LOS for the study area intersections. One of the important conditions for determining LOS at an intersection is the number of lanes provided for each movement on each approach at the intersection. The 2025 and 2035 intersection geometry for the study area intersections, shown in **Figure 21** and **Figure 22** respectively, was developed based on the findings of the roadway segment LOS analysis completed in the previous section, *Future Roadway Segment Level of Service*. The 2025 and 2035 LOS for the signalized intersections within the study area are shown in **Figure 23** and **Figure 24**, respectively. *Working Paper #2: Evaluation Criteria and Plan for Improvements* provides the complete results of the 2025 and 2035 LOS analyses.

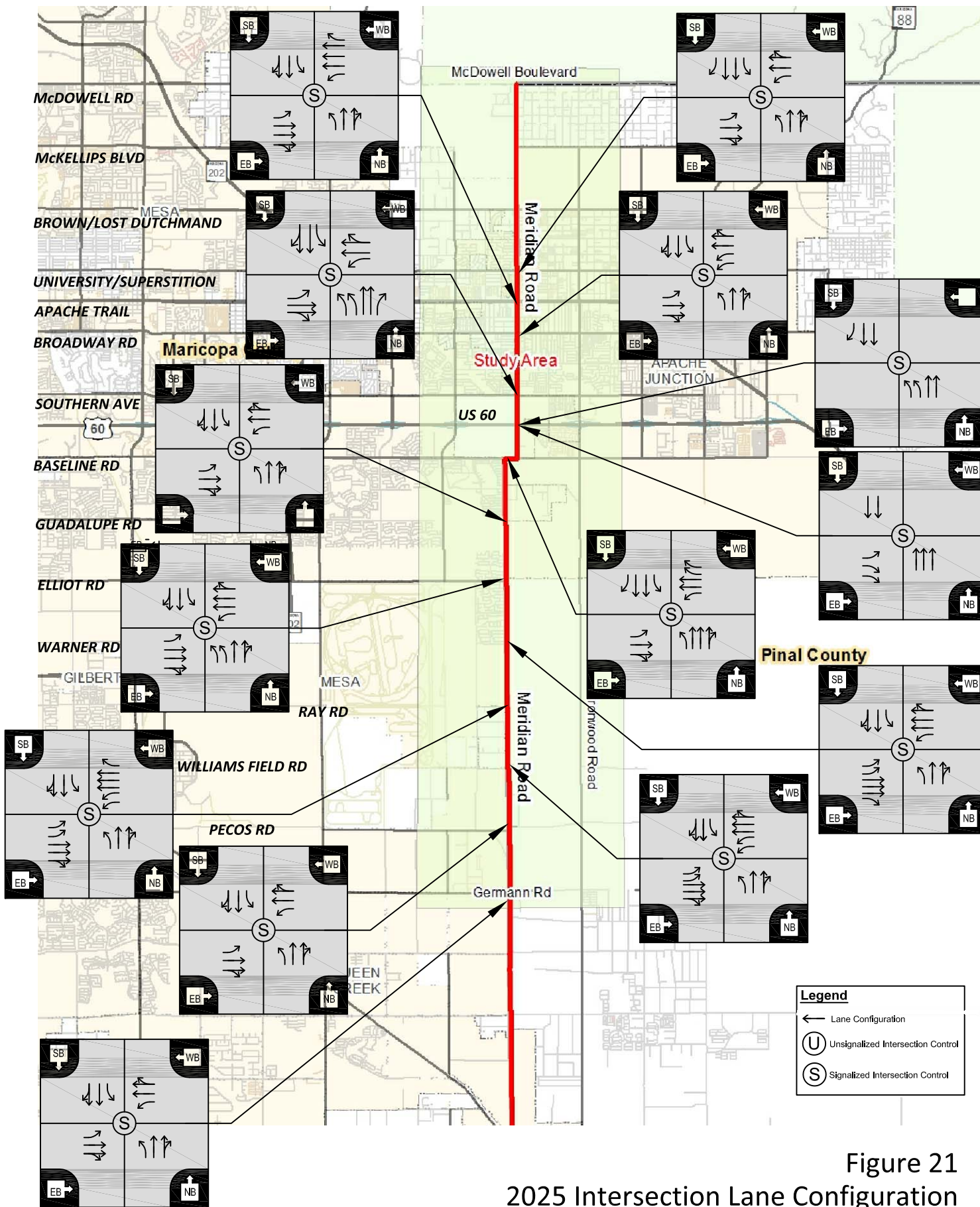

Figure 21  
2025 Intersection Lane Configuration



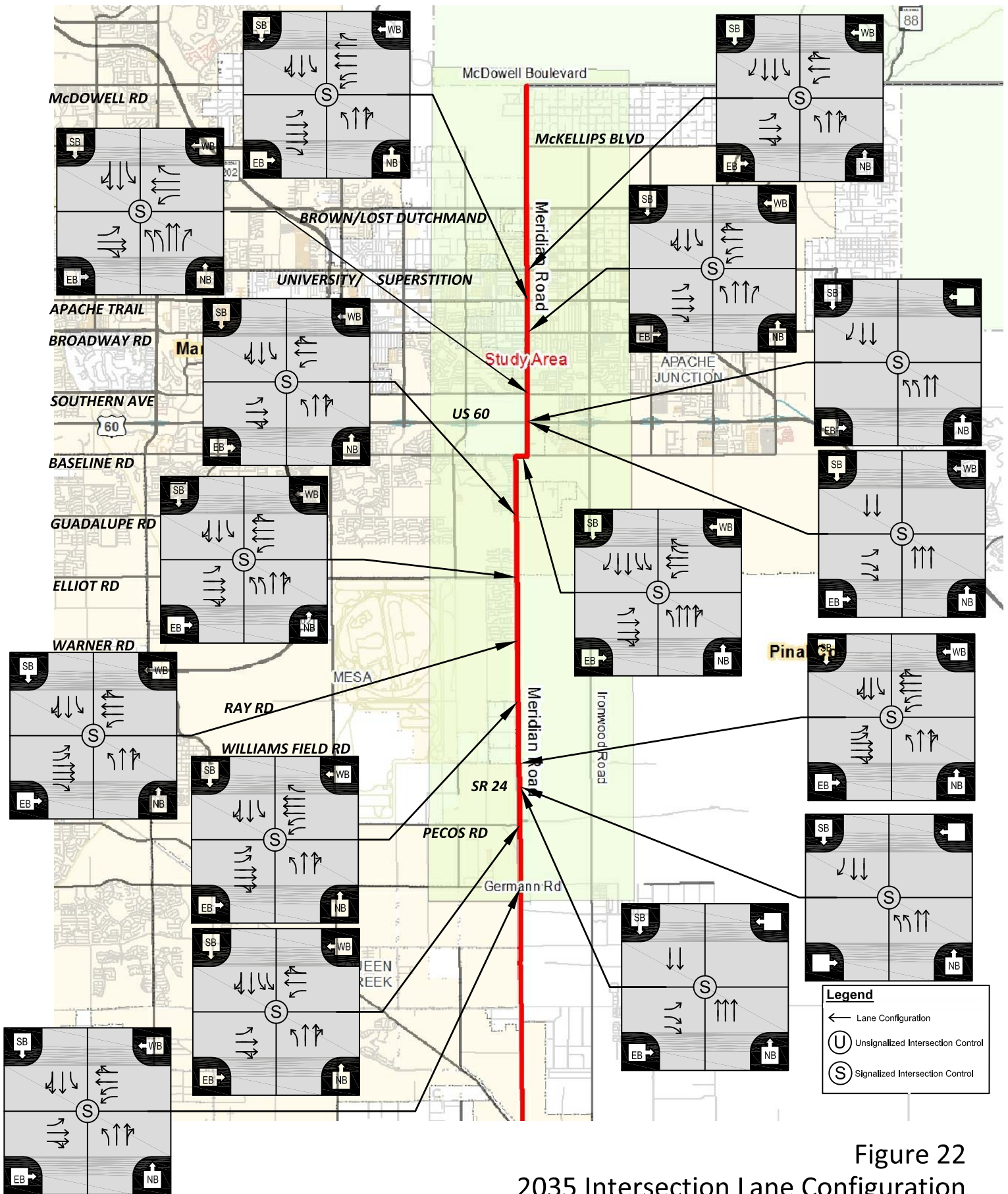

Figure 22  
2035 Intersection Lane Configuration



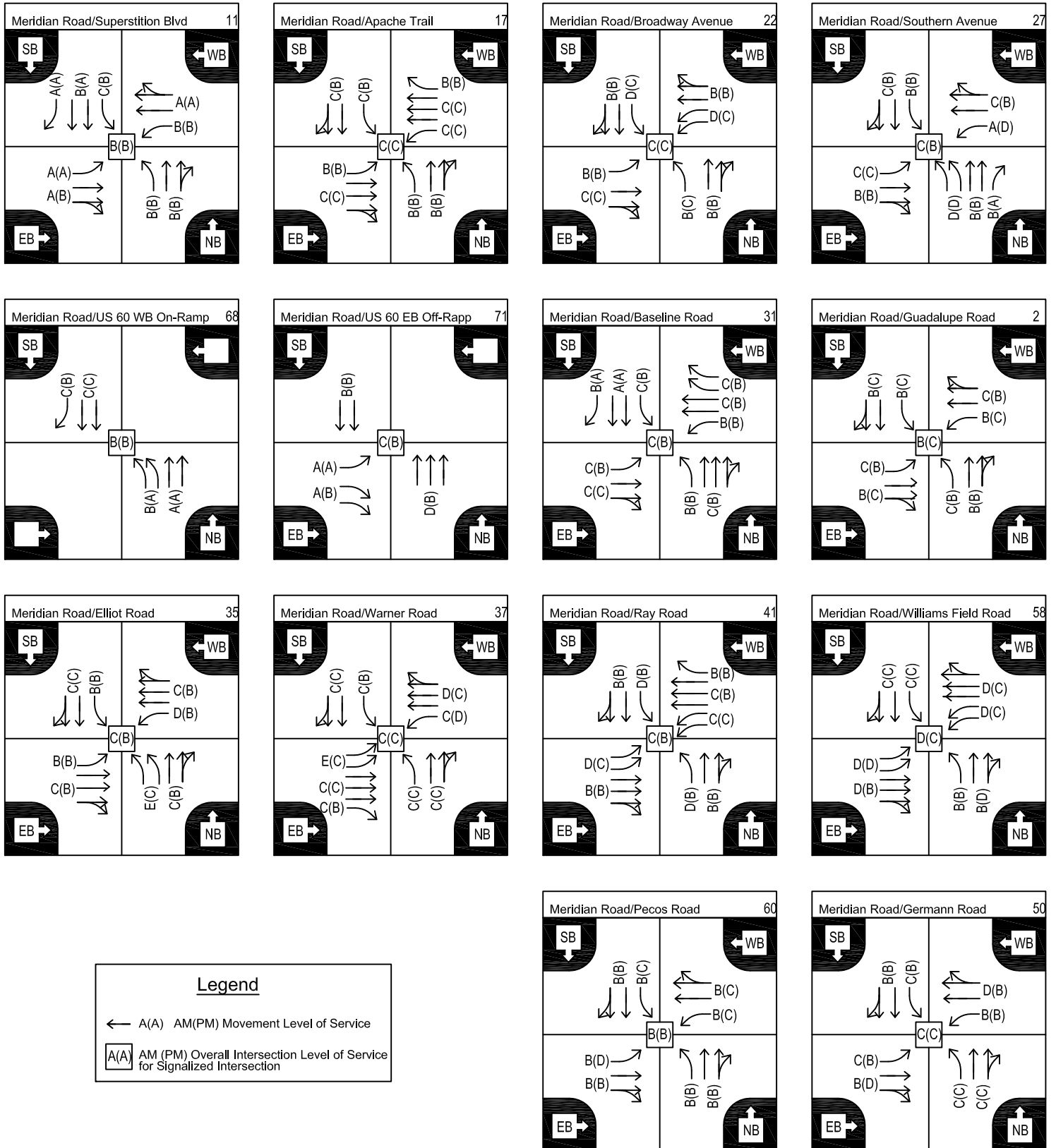
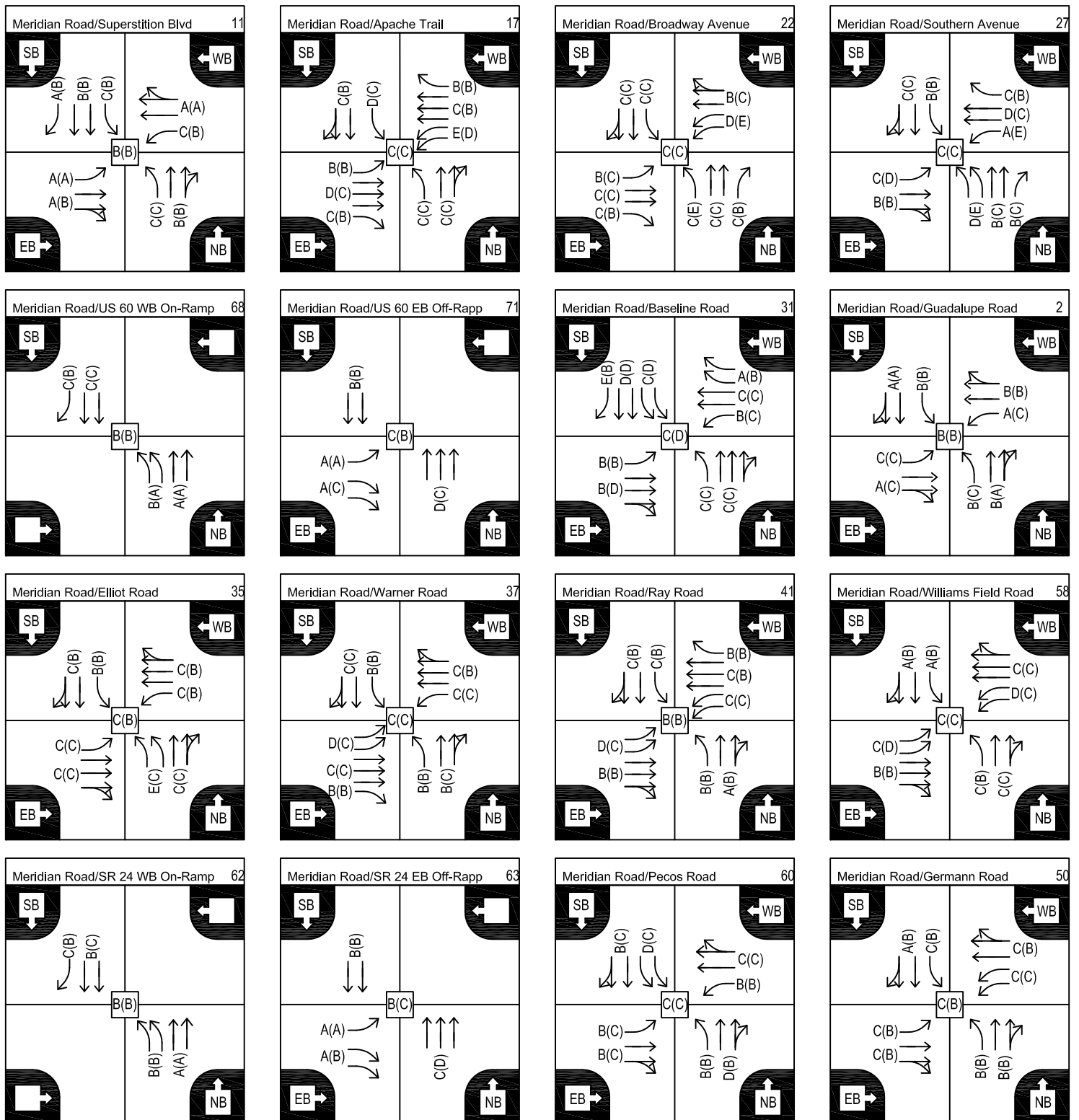

Figure 23  
2025 Intersection Level of Service



**Legend**

← A(A) AM(PM) Movement Level of Service

A(A) AM (PM) Overall Intersection Level of Service for Signalized Intersection

Figure 24  
2035 Intersection Level of Service

**Traffic Impacts**

The results of the 2025 LOS analysis for a roadway segment indicate that most segments of Meridian Road south of Southern Avenue will operate unacceptably as a three-lane section. It is anticipated that Meridian Road will operate within the threshold of acceptable operations at a LOS of C or better as a two-lane undivided roadway between McDowell Boulevard and Lost Dutchman Boulevard, as a three-lane section south of Lost Dutchman Boulevard to Southern Avenue and as four-lane divided roadway south of Southern Avenue to Germann Road. The results of the 2025 roadway segment analysis are depicted in **Figure 25**.

The results of the 2035 LOS analysis for a roadway segment indicate that most segments of Meridian Road south of Superstition Boulevard will operate unacceptably as a three-lane section. It is anticipated that Meridian Road will operate within the threshold of acceptable operations at a LOS of C or better as a two-lane undivided roadway between McDowell Boulevard and Lost Dutchman Boulevard and as four-lane divided roadway south of Lost Dutchman Boulevard to Germann Road. The results of the 2035 roadway segment analysis are depicted in **Figure 26**.

The results of the 2025 and 2035 Synchro analysis show that the typical intersection lane configuration for Meridian Road within the study area is a single left-turn and one through lane with a shared through/right-turn lane for the northbound and southbound directions. Several intersections deviate from this typical intersection lane configuration and are shown in **Table 11** and **Table 12**, respectively for 2025 and 2035.

**Table 11: 2025 Meridian Road Intersection Lane Configuration Deviations**

Meridian Road Intersection	Movement	Deviation		
		Dual Left-Turn Lanes	Exclusive Right-Turn Lane	Three Through Lanes
University Drive/ Superstition Boulevard	SB		X*	
Southern Avenue	NB	X	X	
US 60	NB	X		X
	SB		X	
Baseline Road	NB			X
	SB		X	
Elliot Road	NB	X		

\*Under existing conditions

**Table 12: 2035 Meridian Road Intersection Lane Configuration Deviations**

Meridian Road Intersection	Movement	Deviation		
		Dual Left-Turn Lanes	Exclusive Right-Turn Lane	Three Through Lanes
University Drive/ Superstition Boulevard	SB		X*	
Broadway Road	NB		X	
Southern Avenue	NB	X	X	
US 60	NB	X		X
	SB		X	
Baseline Road	NB			X
	SB	X	X	
Elliot Road	NB	X		
SR 24	NB	X		X
	SB		X	
Pecos Road	SB	X		

\*Under existing conditions



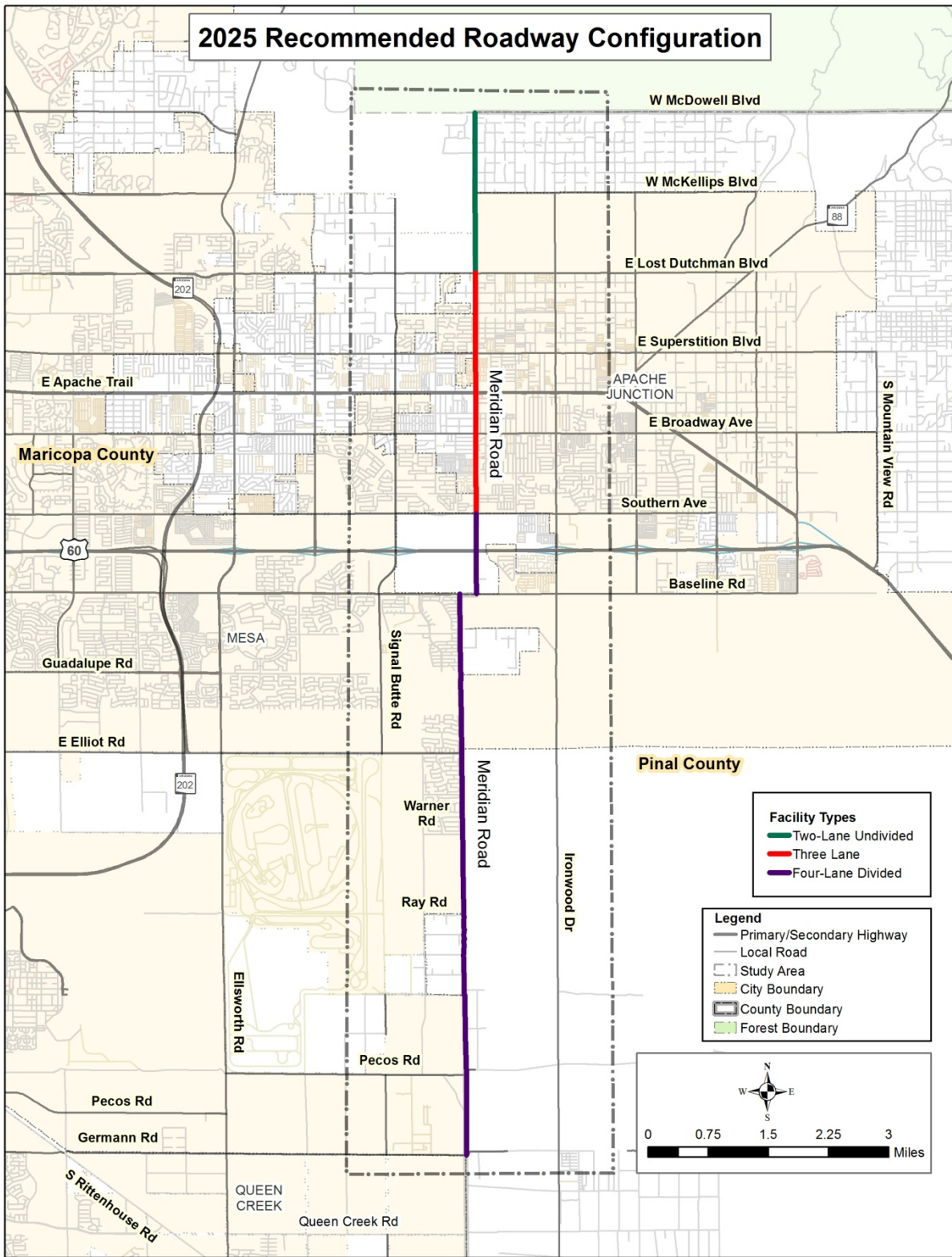

Figure 25: 2025 Recommended Roadway Configuration

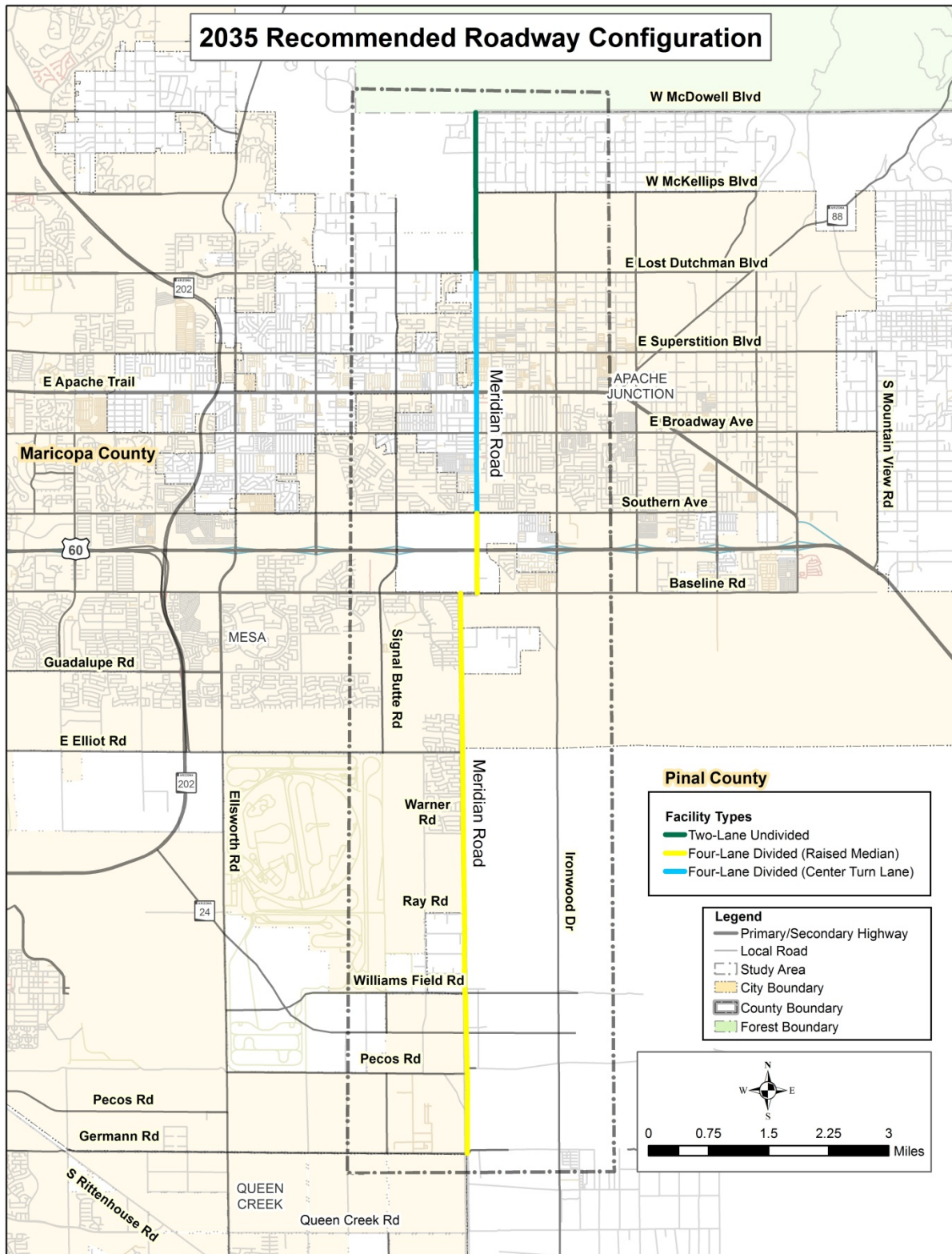

Figure 26: 2035 Recommended Roadway Configuration

## V. Environmental Summary

This section summarizes the existing environmental conditions for the Meridian Road Corridor Study Area, which is generally bounded by Germann Road on the south, McDowell Boulevard on the north, Ironwood Road on the east and Signal Butte Road on the west. This environmental overview is not intended to meet the requirements of the National Environmental Policy Act (NEPA). Additional information is available in *Working Paper #1: Existing and Future Conditions Inventory*.

The Environmental Summary describes the study area in terms of its physical and natural, and cultural resources contexts. The study area includes lands within the Cities of Mesa and Apache Junction, and the counties of Maricopa and Pinal. The information presented is based on existing data sources from municipal, county, state, and federal agencies; and, on a “windshield” survey of the study area.

### Summary of Socioeconomic Environment Findings

The study area falls within the jurisdictional boundaries of City of Apache Junction, City of Mesa, Town of Queen Creek, Pinal County and Maricopa County. Private entities own a majority of the land within the study area, with a small portion owned by Arizona State Land Department and the Bureau of Reclamation.

The study area is predominately White with some Hispanics, African American, Asian, American Indian Alaskan Native, Native Hawaiian Pacific Islanders, and others. Based on 2010 US Census there are elderly, low-income, disabled and female heads of household populations found in the study area; however, these groups represent a small percentage of the overall population.

### Summary of Physical and Natural Environment Findings

The southern portion of the study area is located in the Lower Colorado River Sonoran Desert scrub. The northern portion of the study area is in the Sonoran Desert scrub - Arizona Upland Subdivision where vegetation generally appears similar to a scrubland or low woodland of leguminous trees with intervening spaces held by several open layers of shrubs and perennials succulents. No permanent natural water sources exist within the study area; however, numerous ephemeral washes dissect the study area. The middle portion of the study area is dominated by creosote bushes with scattered ironwood, mesquite and palo verde. The study area provides cover and foraging opportunities for wildlife due to the presence of vegetation and ephemeral washes.

A scoping letter was submitted to Arizona Game and Fish Department (AGFD) for any listing of threatened and endangered species in the study area. Available and existing literature review shows the study area provides suitable habitat for various native wildlife species, but does not contain suitable habitat for any federally threatened and endangered species or candidates species listed in for the southern portion of the study area south of US 60.

The Meridian Road corridor is in an air nonattainment area for carbon monoxide, ozone, and particulate matter smaller than 10 microns, which have transportation control measures in the State Implementation Plans and Federal Implementation Plan. Existing noise data are not currently available for the study area. During subsequent environmental documentation activities for the study area,

ambient noise levels may need to be monitored at specific locations. The future noise quality for the study area would need to be evaluated against the existing noise data to conform to the ADOT Noise Abatement Policy.

Potential jurisdictional waters of the US located in the study area include several unnamed washes. These should be delineated before construction to determine the need for Sections 401 and 404 permits. The Central Arizona Project (CAP) canal traverses the study area at US 60 and Meridian Road. The area south of the Powerline Floodway is part of the East Mesa Area Drainage Master Plan which is under study. There are portions of the northern part of study area that occur within Zone A of the FEMA Flood Map.

A review of available Arizona Department of Quality (ADEQ) databases revealed leaking underground storage tank (LUST) locations which are shown in **Table 13**.

**Table 13: Leaking Underground Storage Tank Locations**

Location	UTM	Type
At Signal Butte along West Apache Trail	X:444424, Y: 3697549	LUST
Between Meridian and Mountain Road along West Apache Trail	X: 445532, Y: 3697589	LUST
Between Meridian Road and Ironwood along West Apache Trail	X: 447071, Y: 3697589	LUST
At Ironwood along West Apache Trail	X: 447644, Y: 3697393	LUST
At Delaware Road and Broadway	X:446862, Y: 3696650	LUST
East Baseline Road east of Meridian Road	X: 446340, Y: 3693443	LUST
On West Germann Road east of Meridian Road	X: 446288, Y: 3682205	LUST

Under Resource Conservation and Recovery Act (RCRA) the Environmental Protection Agency compiles a database of facilities that are involved in the generation of hazardous materials. This database is from the Arizona Department of Environmental Quality RCRAInfo Database, dated June, 2012 and Allands checked for Federal RCRA facilities located within a 0.125 mile search distance from subject property exterior boundaries. **Table 14** lists the RCRA facilities within 0.125 mile of the Meridian Road Corridor Study study area.



Table 14: Resource Conservation and Recovery Act (RCRA) Facilities

EPA ID	FACILITY	ADDRESS	NOTIFICATION DATE	STATUS
AZR000047035	Apache Junction Cancer Center	2080 W Southern Ave	3/1/2008	CEG
AZR000047034	Apache Junction Cancer Center	2080 W Southern Ave	2/23/2009	CEG
AZR000044545	EVDI Medical Imaging Ironwood	2080 W Southern Ave	1/29/2009	SQG
AZS000047480	HD Automotive & Machine Shop	2210 W Apache Trail	8/31/2004	N
AZR000500769	Statewide Environmental Oil Services	2475 W Dallas Ave	2/10/2008	N
AZR000043166	Wal Mart Store 1381	2555 W Apache Trail	3/2/2009	CEG
AZR000042374	Solvents Systems Inc	4793 S Desert View Dr	5/8/2006	N
AZE050323002	Sunbelt Tank Services	4932 S Penny Lane	6/21/2005	N
AZR000037812	MUSD 4 Pur Oper / Sousa Elem	616 N Mountain	2/14/2005	CEG
AZD982491649	TRW VSSI / TRW Vehicle Safety Systems Mesa II Facility	11202 E Germann Rd	2/3/2010	LQG / CORRACTS
AZR000506931	CMC Steel Arizona	11444 E Germann Rd	2/2/2009	N
AZE060911001	CRM Of America LLC	11400 E Pecos Rd	4/23/2008	SQG
AZR000004846	Walgreens 2963	11545 E Apache Trail	7/31/2001	N
AZR000503607	Wal-Mart Super Center 3833	1606 S Signal Butte Rd	3/2/2009	SQG
AZR000506899	Bright Now Dental	1804 S Signal Butte Rd	1/12/2009	CEG
AZR000506196	Gateway Smiles	1901 S Signal Butte Rd	1/8/2009	CEG
AZR000001016	Fuji Film Electronic Materials USA / Arch Chemicals Inc / Olin Electronic Materials	6550 S Mountain Rd	3/25/2010	LQG
AZR000002394	MGC Pure Chemicals America Inc	6560 S Mountain Rd	2/21/2008	N
AZR000046987	Top Drawer Components Apache Junction	5154 S Delaware Dr	2/17/2009	CEG

### Summary of Cultural Inventory Findings

Approximately 65 archaeological projects have taken place within one mile of the project area; because none of them examined any portion of the project corridor within the past 10 years, no further information about these previous projects is provided herein. Twenty-five sites have been previously recorded in the review area, of which three occur within or immediately adjacent to the 200-foot-wide corridor. The three sites that occur within or immediately adjacent to the 200-foot-wide corridor are:

- **NA15612** – a small Hohokam artifact scatter on the west side of Meridian Road between US 60 and Baseline Road; AZSITE has no record of its National Register eligibility.
- **AZ FF:9:17(ASM)** – the historic US Highway 80, which follows the Apache Trail alignment across the project corridor; the site as a whole has been determined eligible under Criteria A and D, but the segment through the project corridor lacks integrity of design, setting, materials, workmanship, and feeling, so it does not contribute to the site’s overall eligibility.
- **AZ U:10:36(ASM)** – a large Hohokam resource procurement site; the western extent of the site intersects the project corridor roughly midway between Guadalupe and Elliot roads.

Based on the results of the desktop search of the AZSITE database, the Meridian Road corridor has not been surveyed within the past 10 years. The windshield survey conducted on July 26, 2012 revealed that the corridor occurs in a mixed urban and rural environment; although portions of the corridor have been

developed, others contain largely undisturbed desert. Therefore, it is recommended that the undeveloped areas within the project corridor be subject to a Class III pedestrian survey to identify any previously recorded cultural resources. It is possible that AZ U:10:36(ASM) will require mitigation prior to construction; NA15612 may also require additional work if the survey determines that the site extends into the project corridor. It is unlikely that AZ FF:9:17(ASM) will require further work due to the lack of integrity; it is recommended that a formal evaluation of the historic highway alignment be conducted at the time of the Class III survey. In addition, a historic building assessment is recommended to determine if any standing buildings 45 years or older occur along the project corridor.

## VI. Development of Alternatives

This section documents the development of conceptual alternatives considered for Meridian Road. The development of alternatives were based upon information collected and documented in the Working Papers, jurisdiction design guidelines and criteria, and input received from the Meridian Road Technical Advisory Committee (TAC).

### Alignment Alternatives

The study has been examined in two sections. The roadway alignment for the northern half of the corridor between US 60 and McDowell Boulevard forms the westerly boundary of the City of Apache Junction's roadway network. For the majority of its length Meridian Road is a two lane roadway with some widening to three and four lanes at the approach and departure of the intersections at Broadway Road, Apache Trail and Superstition Boulevard.

The roadway alignment for the southern half of the Meridian Road corridor between Baseline Road and Germann Road is largely undefined. A two mile section from half mile north of Elliot Road to half mile south of Warner Road is a two lane street off-set west of the section line. The alignment is either a dirt road or non-existent on other sections of undeveloped land.

### **Conceptual Analysis for Northern Section of Meridian Road**

Concepts were developed for the northern section of the project relating to the lane configuration and right-of-way requirements. See the *Existing Right-of-Way* section for more detailed information on existing right-of-way along this section of the Meridian Road corridor. The roadway lane configuration is dealt with in the *Roadway Segment Lane Configuration* section of the report.

### **Conceptual Alternatives for Southern Section of Meridian Road**

Conceptual alternatives for the southern section were developed based upon identified corridor issues, the projected traffic volumes and transportation/connectivity needs. Design guidelines relating to roadway cross sections and horizontal alignment from City of Apache Junction, City of Mesa, Maricopa County Department of Transportation (MCDOT) and Pinal County were used to generate the conceptual alternatives.

#### ***Alternative 1 – No Build Alternative***

The no-build alternative considers how the existing roadway network would function if the southern section of the corridor was not constructed.

#### ***Alternative 2 – Section Line Alignment***

This alternative proposes to locate the corridor improvements symmetrically about the section line. It makes full use of the existing right-of-way dedicated to the west of the section line. Alternative 2 is depicted in **Figure 27**.

#### ***Alternative 3 – Eastern Shift***

An easterly shift alignment is considered to minimize impacts on existing residential parcels and a drainage channel adjacent to the section line. An alignment shift of 1,100 feet to the east is proposed to

line-up with the section of the Meridian Road north of Baseline Road. Alternative 3 is depicted in **Figure 27**.

#### *Alternative 4 – Meandering Alignment*

The meandering alignment consists of minor shifts in the alignment either east or west of the section line to reduce impact to existing properties and use existing right-of-way. Alternative 4 is depicted in **Figure 27**.

#### **Section Line Shift at Baseline Road**

Two reverse curve alignment adjustments were considered to align the off-set in the monument line that occurs at Baseline Road and are described below. The section line shifts at Baseline Road Alternatives are shown in **Figure 28**.

#### *Alternative B1 – US 60 to Baseline Road*

With this alternative the alignment shift to the west begins just south of US 60 and ties into the monument line at Baseline Road. This alignment would require a frontage road connector to maintain access to the existing businesses on the east side of Meridian Road.

#### *Alternative B2 – South of Baseline Road*

This alternative holds the Meridian Road alignment on the monument line until Baseline Road. South of Baseline Road the alignment would curve to the west to line up with the section line approximately half mile south of Baseline Road. This alignment would maintain access to Meridian Road businesses between US 60 and Baseline Road.



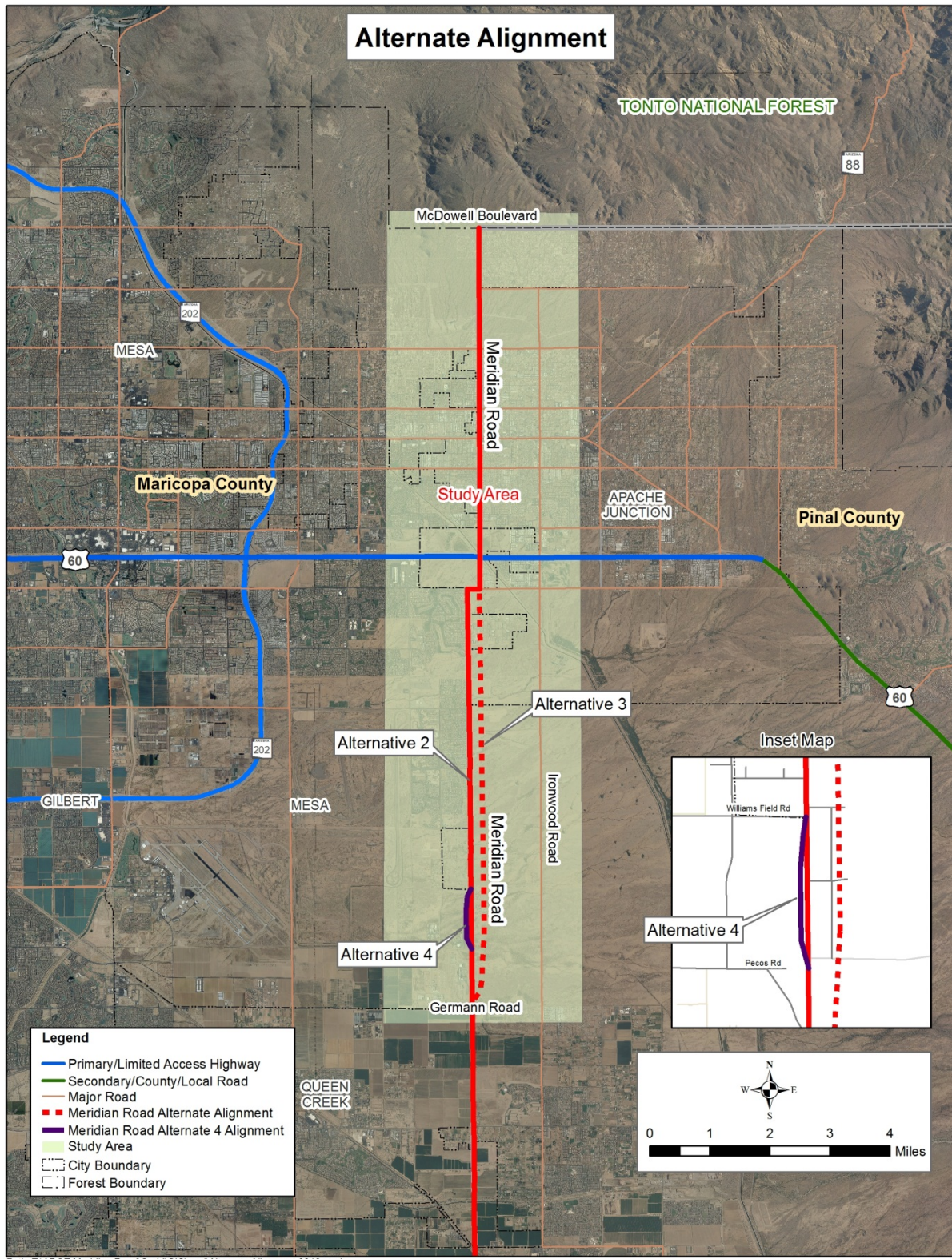

Figure 27: Conceptual Alternatives for Southern Section of Meridian Road



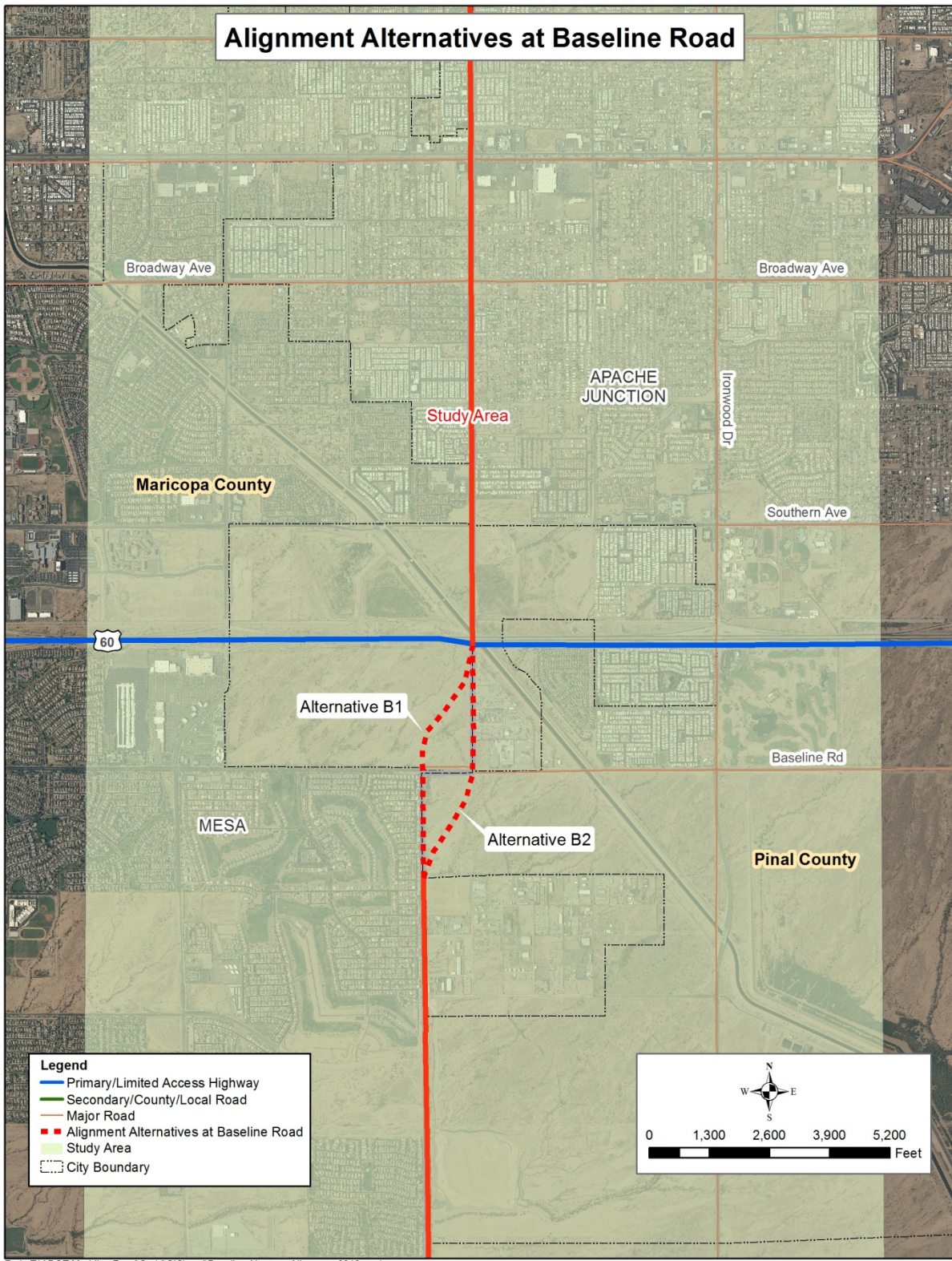

Figure 28: Section Line Shift at Baseline Road Alternatives

## VII. Evaluation of Alternatives

This section documents the evaluation of the conceptual alternatives developed for Meridian Road. The evaluation of alternatives was based upon jurisdiction design guidelines and criteria, input received from the Meridian Road TAC, and input received during the public open houses. The alternatives evaluation was conducted to the extent necessary to provide a meaningful comparative analysis of feasible improvement alternatives, leading to the selection of a preferred alternative.

### Evaluation Criteria

A preliminary matrix was developed in order to evaluate the alternatives. The evaluation criteria and corresponding questions to be addressed are as follows:

- Constructability Issues – Is the alternative constructible?
- Engineering Complexity – Does the alternative involve a more complicated design or create additional engineering challenges?
- Environmental/Cultural Issues – Is there the potential for finding historical and/or archeological artifacts? Are historic preservation activities likely required?
- Potential Utility Conflicts – Will the alternative impact existing utilities. Will new utilities be required?
- Traffic Operations – Will the alternative improve traffic flow and increase regional connectivity?
- Public Acceptability – Is the corridor alternative likely to generate negative feedback from the community?
- Socioeconomic Impacts – Does the alternative impact existing residential parcels/developments (i.e. right-of- way, or existing homes)?

The corridor alternatives were evaluated using one of three rankings based upon the perceived response for each evaluation criteria question. The three ranking levels are as follows: Minimum impact/high performance, Moderate impact/moderate performance, or High impact/low performance.

### Alternative Screening

**Table 15** summarizes the results of the initial alternative screening.

Table 15: Alternative Screening Results

Evaluation Criteria	Alternative Alignments			
	Alt 1	Alt 2	Alt 3	Alt 4
Constructability Issues	○	○	○	○
Engineering Complexity	○	○	⊗	⊗
Environmental/Cultural Issues	○	○	○	○
Potential Utility Conflicts	○	⊗	●	⊗
Traffic Operations	●	○	○	○
Public Acceptability	●	⊗	⊗	○
Socioeconomic Impacts	○	⊗	○	⊗

○ Minimal impact/high performance

⊗ Moderate impact/performance

● High impact/low performance

## Preferred Alternative

### Preferred Meridian Road Alignment

All three of the build alternatives are anticipated to have similar amount of constructability issues related to traffic control and maintenance of traffic during construction. Minimal environmental issues are anticipated with all the alternatives. Input received on the alternatives from the TAC at the meeting and a subsequent agency meeting with ASLD was generally in favor of the alignment staying on the section line because it resulted in more equitable right-of-way takes from property owners and did not place a large burden on State Trust Land. Alternative 4 was selected as the preferred alternative because it followed the section line for most of its length except the area between Williams Field Road and Pecos Road where the alignment shifted east to avoid impacting existing residential developments.

### Preferred Section Line Shift

Based on the input received from the TAC team and engineering considerations the preferred alternative for the two reverse curve alignments would be Alternative B1. While there was no real preferences between the alternatives from the TAC team, both were considered viable alignments, the alignment south of Baseline Road would pass through an area of land subsidence and earth fissures. In addition, consideration has to be given to the provision of a traffic interchange (TI) with US 60. Currently a half-TI consisting of a partial cloverleaf with ramps to/from the west is proposed. A new study is proposed by ADOT to investigate the provision of additional general purpose lanes along US 60. As part of this study the location of a full interchange will be examined. Preliminary work suggest that the TI will be placed west of the existing Meridian Road bridge and probably line up with the section line south of Baseline Road.



### VIII. Design Features

There are four separate jurisdictions within the Meridian Road Corridor, each with their own set of design guidelines. Those jurisdictions are the City of Apache Junction, City of Mesa, Maricopa County and Pinal County. In order to address the needs and purposes of the Meridian Road Corridor Study, a consensus had to be reached between the Local agencies/jurisdictions and private stakeholders regarding the preferred interim and ultimate facility type and access control design elements. Additional information on the major design features and access control design elements is available in *Working Paper #2: Evaluation Criteria and Plan for Improvements*.

At this time the local agencies have not determined which of them will have the ultimate responsibility for what segments of Meridian Road. When that decision is made, and when the road is improved, the lead agencies design standards will govern the development of the roadway. Until that time, the agencies generally agree to the guidelines presented in the typical cross sections below.

A number of interviews were carried out with the individual agencies with a view to agreeing on a Memorandum of Understanding (MOU) on how the Meridian Road corridor will develop and who would have the ultimate responsibility to maintain the certain sections of the road. A sample MOU was developed (See **Appendix D**) based on feedback from the agencies. Although this MOU does not set out specific standards or responsibilities it will allow the agencies to ‘pledge’ to work together to develop Meridian Road in the future.

#### Typical Cross Section

An Ultimate Roadway Cross Section was developed for Meridian Road between Southern Avenue and Germann Road providing a 6-lane roadway with a 16’ raised median, bike lanes and detached sidewalks as depicted in **Figure 29**.

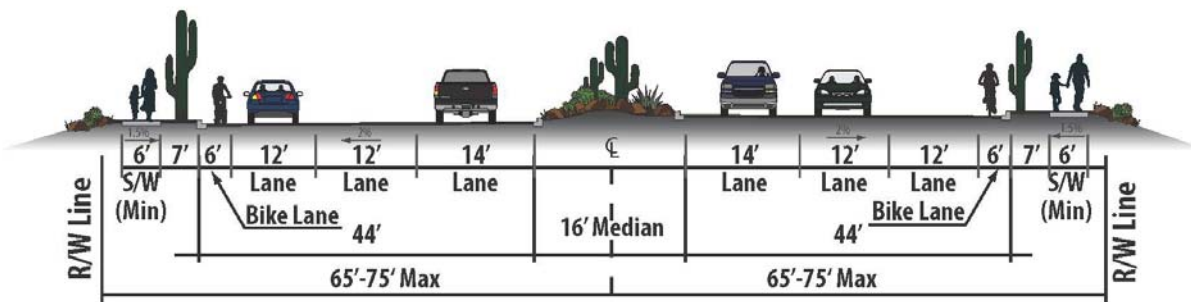

**Figure 29: Ultimate Roadway Cross Section – Southern Avenue to Germann Road**

A preferred Ultimate Roadway Cross Section was developed for Meridian Road north of Southern Avenue providing a 4-lane roadway with a 16’ painted or raised median, bike lanes and detached sidewalks as depicted in **Figure 30**.



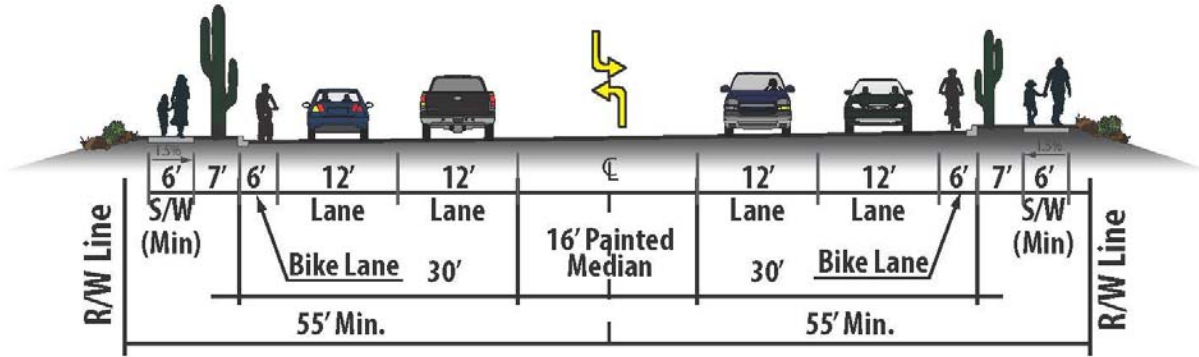

Figure 30: Ultimate Roadway Cross Section – Lost Dutchman Boulevard to Southern Avenue

A preferred Ultimate Roadway Cross Section was developed for Meridian Road between Lost Dutchman Boulevard and McDowell Boulevard providing a two lane road, bike lanes and detached sidewalks as depicted in **Figure 31**.

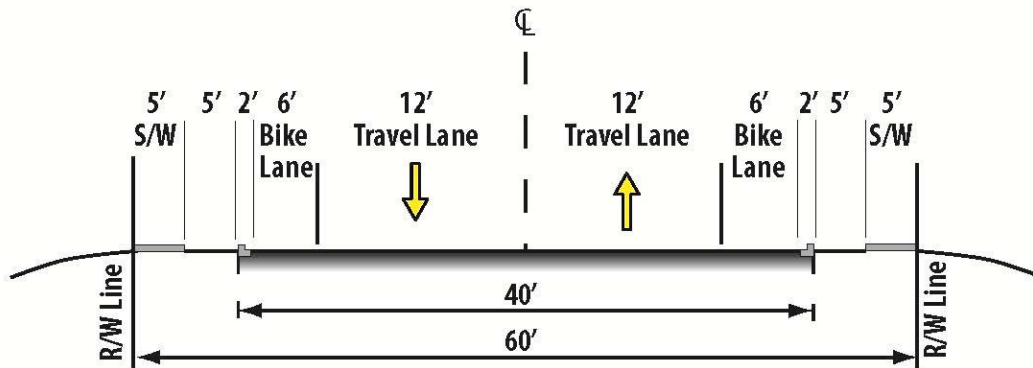

Figure 31: Ultimate Roadway Cross Section – Lost Dutchman Boulevard to McDowell Boulevard

Until development and traffic volumes warrant the ultimate cross section, interim cross sections were developed based on the results of the roadway segment LOS analysis. **Figure 32** shows the recommended interim cross section for Meridian Road between McDowell Boulevard and Lost Dutchman Boulevard. **Figure 33** depicts potential interim cross section for Meridian Road between Lost Dutchman Boulevard and Germann Road. **Figure 34** depicts potential interim cross section for Meridian Road between Southern Avenue and Germann Road. The only difference between **Figure 33** and **Figure 34** between Southern Avenue and Germann Road is the median type. The median type will depend on the access control requirements developed and agreed upon by the key agencies. As traffic warrants, a second travel lane can be added in each direction to the interim cross section to obtain the ultimate cross sections.

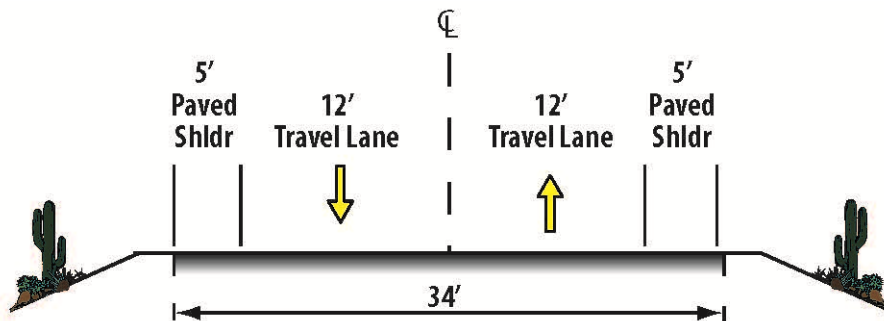

Figure 32: Interim Cross Section: McDowell Boulevard to Lost Dutchman Boulevard

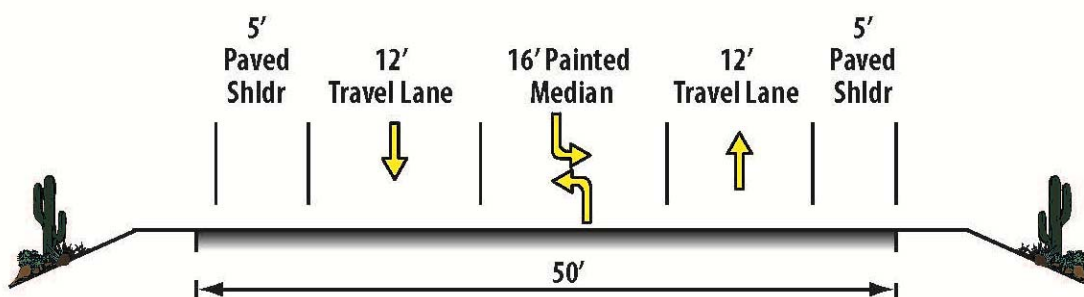

Figure 33: Interim Cross Section: Lost Dutchman Boulevard to Germann Road

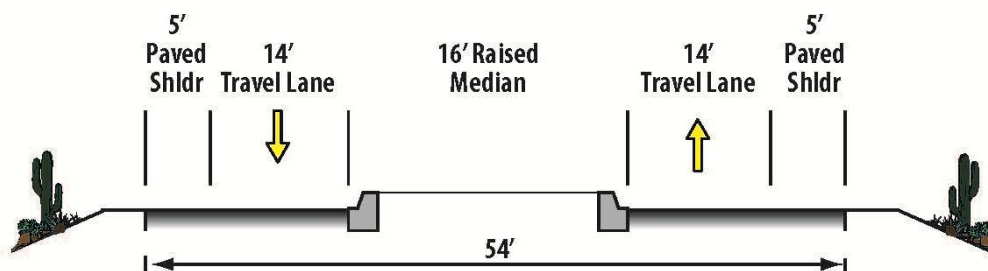

Figure 34: Interim Cross Section: Southern Avenue to Germann Road

## Phased Construction

### Near-Term Improvement Recommendations

Based on the traffic analysis results and the projected development patterns, the following improvements are either programmed or recommended for the near-term (by 2017), although the timing of these improvements will be dependent on the surrounding area development:

- The US 60/Meridian Road Traffic Interchange is programmed to be constructed by 2017;

- The Southern Avenue/Meridian Road intersection is programmed to be signalized by 2017 and widened to accommodate a left-turn lane and a shared through/right-turn lane in each direction; and
- By 2017, Meridian Road is recommended to be extended from Baseline Road to Elliot Road with intersection improvements at Baseline Road, Guadalupe Road and Elliot Road to improve connectivity within the corridor with the addition of programmed improvements.

### **Mid-Term Improvement Recommendations**

Based on the development pattern projected by the MAG, the following improvements are anticipated to occur in the mid-term (2017-2025), although the timing of these improvements will be dependent on the surrounding area development:

- Meridian Road is anticipated to be widened to a three-lane roadway from Lost Dutchman Boulevard to Southern Avenue;
- Meridian Road is anticipated to be widened to a four-lane divided roadway from Southern Avenue to Elliot Road; and
- Meridian Road is anticipated to be extended from Warner Road to Germann Road as a four-lane divided roadway by 2025 including constructing Meridian Road intersections with Ray Road, Williams Field Road, Pecos Road and Germann Road as well as the SR 24/Meridian Road Traffic Interchange.

With the gaps that currently exist in Meridian Road likely to be filled during the mid-term timeframe, this will result in a continuous arterial with freeway access to US 60. These improvements are anticipated to significantly alter traffic volumes on Meridian Road as well as along some of the adjacent parallel arterials, such as Ironwood Road.

### **Long-Term Improvement Recommendations**

Based on the development pattern projected by MAG, the following improvements are anticipated to occur in the mid-term (2025-2035), although the timing of these improvements will be dependent on the surrounding area development:

- Meridian Road is anticipated to be widened to a four-lane roadway from Lost Dutchman Boulevard to Southern Avenue; and
- The SR 24/Meridian Road Traffic Interchange is anticipated to be constructed by 2035.

### **Ultimate Improvement Recommendations**

The following improvement is anticipated to occur in the ultimate condition (beyond 2035), although the timing of these improvements will be dependent on the surrounding area development:

- Meridian Road is anticipated to be widened to the full six-lane cross-section between Southern Avenue and Germann Road.

## Access Management Recommendations

Access management guidelines from the various agencies were reviewed to establish the access management strategy for the Meridian Road Corridor. This can be accomplished by establishing a program of legal, administrative, and technical strategies with the appropriate balance between property access and the need to control access to serve public need. Ideally, these strategies will be implemented through planning practices, rules, engineering standards, and procedures resulting in access decisions that successfully, fairly, and consistently determine access management for each unique situation. **Table 16** summarizes the access control within the study corridor for the various jurisdictions.

As an arterial street, Meridian Road must accommodate traffic operations and a moderate level of property access while promoting safety of travel. To accomplish these goals recommendations on intersection, driveway and median placement are set out below.

### **Intersection Spacing**

Meridian Road is part of an arterial street grid system. Therefore, it is encouraged to restrict signalized intersections to the half-mile and mile locations only. It is recommended that each intersection be constructed to its ultimate configuration including dedicated left and right turn lanes where practical. Non-signalized intersections should be placed a minimum of 660 feet apart. Opportunities to consolidate non-signalized intersections with less than 660 feet of separation should be considered.

### **Driveway Locations**

It is recommended that access be limited for new residential driveways along the Meridian Road Corridor. Future residential developments shall be encouraged to tie directly into east-west collector or minor arterial roadways that connect to Meridian Road.

### **Median Locations**

Raised medians provide access control and improve safety and operations by minimizing midblock left turns. Median openings may allow for full or partial turning movement access. Full access allows for left turns into and out of an adjacent site. Partial access allows for left turns from the street to an adjacent site only. Care should be taken to limit the number of median openings so as not to defeat the purpose of the raised median. In general, full access median openings may be provided at sixth-mile increments (880 feet). Additional median openings should be the partial access type. Median openings are not recommended less than 660 feet from an arterial-to-arterial intersection.



Table 16: Access Control Guidelines per Jurisdiction (for Urban Arterial Roads)

Access Control Feature	Pinal County	City of Mesa	City of Apache Junction	MCDOT
Medians	Divided with full or directional median openings at ¼ mile spacing	Divided with full or directional median openings at ¼ mile spacing	Divided with full or directional median openings at ¼ mile spacing	Divided with full or directional median openings at ¼ mile spacing
Traffic Signal Spacing	¼ mile and ½ mile locations fully coordinated and progressed where warranted	Between ¼ and ½ mile and between ¼ and ½ mile locations fully coordinated and progressed where warranted	¼ mile and ½ mile locations fully coordinated and progressed where warranted	¼ mile minimum, preferably ½ mile
Typical Traffic Control	Signalized, four-way stop	Signalized, four-way stop	Signalized, four-way stop	Signalized, four-way stop
Access Driveway	100 feet from intersection	100 feet from intersection	100 feet from intersection	85 feet from intersection
Full Access Driveway from Signal	660 feet	880 feet	880 feet	230 feet
Partial Access Driveway from Signal	330 feet	660 feet	660 feet	115 feet
Driveway spacing	165 feet to 330 feet	60 feet (min)	No Data	65 feet to 330 feet dependent on land use
Grade Separated Interchange Spacing	One mile location where warranted	One mile location where warranted	No Data	No Data
Grade Separated Interchange Type	May include SPUI or tight diamond if warranted and feasible	May include SPUI or tight diamond if warranted and feasible	No Data	No Data
Frontage Road	Possible	Possible	No Data	No Data
On-Street Parking	Prohibited	Prohibited	No Data	No Data

### Additional Recommendations

Adequate sight distance shall be provided at all driveways and intersections. The majority of the land adjacent to the southern half of the Meridian Road Corridor is currently undeveloped. The agencies may want to require developers to dedicate a controlled vehicular access easement to help enforce access control guidelines.

### Right-Of-Way

#### Existing Right-of-Way

The existing right-of-way does not consistently accommodate the typical right-of-way requirements for the desired arterial cross section. Existing right-of-way conditions can generally be characterized as follows and is illustrated in **Table 17**:

- *McDowell Boulevard to Baseline Road* – The existing right-of-way through this segment is primarily 33 feet or 50 feet either side of the section line. Research was carried out by David Evans and Associates, Inc. for the City of Apache Junction which indicated that for some sections of the roadway there was documentation demonstrating that right-of-way had not been preserved. We have assumed that full right-of-way is required in these areas however; further investigation should be carried out to verify this.
- *Baseline Road to Germann Road* – The existing right-of-way through this section is primarily 65 feet to the west of the section line (Maricopa County) with small sections of 55 feet. To the east of the section line (Pinal County) the area is undeveloped State Trust Land and on right-of-way has been preserved at this stage.

**Table 17: Existing Right-of-Way**

Meridian Road Segments		Existing ROW Width		Existing Pavement
From	To	West of Centerline (MCDOT)	East of Centerline (PCDOT)	
McDowell Road	McKellips Boulevard	<ul style="list-style-type: none"> <li>●40' North of Canyon St</li> <li>●55' South of Canyon St</li> </ul>	N/A	●24'
McKellips Boulevard	Lost Dutchman Road	<ul style="list-style-type: none"> <li>●55' from 1/2 mile south of McKellips Blvd to Lost Dutchman</li> </ul>	N/A	●24'
Lost Dutchman Road	Superstition Boulevard	<ul style="list-style-type: none"> <li>●33' North of Windsong St</li> <li>●33' South of Windsong St</li> <li>●55' South of Smoke Tree St</li> <li>●65' South of Silverado Estates</li> </ul>	<ul style="list-style-type: none"> <li>●50' between Lost Dutchman Rd and Concho Street</li> <li>●33' between Concho Street and Tepee St</li> <li>●50' between Tepee St and Shiprock St</li> <li>●33' between Shiprock St and Silverado Estates</li> <li>●50' between Silverado Estates and Superstition Boulevard</li> </ul>	<ul style="list-style-type: none"> <li>●24'</li> <li>●40'</li> <li>●45'</li> <li>●45'</li> <li>●76'</li> </ul>
Superstition Boulevard	Apache Trail	<ul style="list-style-type: none"> <li>●55'</li> </ul>	<ul style="list-style-type: none"> <li>●50' for a 300' segment south of Superstition Boulevard</li> <li>●None from 300' south of Superstition Boulevard to Gregory Street</li> <li>●50' from Gregory St to Apache Trail</li> </ul>	<ul style="list-style-type: none"> <li>●62'</li> <li>●24'</li> <li>●62' at intersection</li> </ul>
Apache Trail	Broadway Avenue	<ul style="list-style-type: none"> <li>●Undefined from Apache Trail to 4th Street</li> <li>●55' from 4th St to 220' north of Broadway Road</li> <li>●40' from 220' north of Broadway Rd to Broadway Rd</li> </ul>	<ul style="list-style-type: none"> <li>●40'</li> </ul>	<ul style="list-style-type: none"> <li>●65'</li> <li>●26'</li> <li>●65' at intersection</li> </ul>
Broadway Avenue	Southern Avenue	<ul style="list-style-type: none"> <li>●65' North of Wier Ave</li> <li>●0' South of Wier Ave to Pueblo Ave</li> <li>●55' from Pueblo Ave to Southern Ave</li> </ul>	<ul style="list-style-type: none"> <li>●0' Broadway Ave to 9th place</li> <li>●50' from 9th place to 16th Avenue</li> <li>●33' from 16th Avenue for 1/4 mile</li> <li>●50' from 1/4 mile south of 16th Street to Southern Avenue</li> </ul>	<ul style="list-style-type: none"> <li>●26'</li> <li>●widens at intersection</li> </ul>
Southern Avenue	Baseline Road	<ul style="list-style-type: none"> <li>●55'</li> </ul>	<ul style="list-style-type: none"> <li>●50'</li> </ul>	●26'
Baseline Road	Guadalupe Road	<ul style="list-style-type: none"> <li>●65'</li> </ul>	N/A	●No Pavement
Guadalupe Road	Elliot Road	<ul style="list-style-type: none"> <li>●55' for 1/2 mile south of Guadalupe</li> <li>●65' for 1/2 mile north of Elliot</li> </ul>	N/A	●No Pavement
Elliot Road	Warner Road	<ul style="list-style-type: none"> <li>●65' north of Mesquite St</li> <li>●55' south of Mesquite St</li> <li>●65' from 200' north of Renfield Ave</li> <li>●70' from 600' north of Warner Road</li> </ul>	N/A	●36'
Warner Road	Ray Road	<ul style="list-style-type: none"> <li>●55' to north of Starkey Ave</li> <li>●65' South of Starke Ave to 545' north of Ray Rd</li> <li>●75' from 545' north of Ray Rd to Ray Road</li> </ul>	N/A	<ul style="list-style-type: none"> <li>●32'</li> <li>●No Pavement</li> <li>●No Pavement</li> </ul>
Ray Road	Williams Field Road	<ul style="list-style-type: none"> <li>●65'</li> </ul>	N/A	●No Pavement
Williams Field Road	Pecos Road	<ul style="list-style-type: none"> <li>●55'</li> </ul>	N/A	●No Pavement
Pecos Road	Germann Road	<ul style="list-style-type: none"> <li>●65' from Pecos Road to 565' north of Germann Road</li> <li>●75' for a 565' segment north of Germann Road</li> </ul>	N/A	●No Pavement

**Required Right-of-Way**

**Table 18** illustrates the required right-of-way based on the following assumptions:

- *McDowell Boulevard to Lost Dutchman Road* – Two-lane road with 40 feet of right-of-way;
- *Lost Dutchman Road to Southern Avenue* – Four-lane arterial street with 110 feet of right-of-way; and
- *Southern Avenue to Germann Road* – Six-lane arterial street with 130 feet of right-of-way.

**Table 18: Right-of-Way Requirements**

Meridian Road Segments		ROW Width Required		Required Pavement Width
From	To	West of Centerline (MCDOT)	East of Centerline (PCDOT)	
McDowell Road	McKellips Boulevard	●None	●40'	●40'
McKellips Boulevard	Lost Dutchman Road	●None from McKellips to 1/2 mile south ●40' from 1/2 mile south of McKellips Blvd to Lost Dutchman	●40'	●40'
Lost Dutchman Road	Superstition Boulevard	●22' North of Smoketree Steet ●None South of Smoketree Street	●5' between Lost Dutchman Rd and Concho Street	●76'
			●22' between Concho Street and Tepee St	●72'
			●5' between Tepee St and Shiprock St	●72'
			●22' between Shiprock St and Silverado Estates	●72'
			●5' between Silverado Estates and Superstition Boulevard	●72'
Superstition Boulevard	Apache Trail	●None to 350' north of Apache Trail ●55' for 350' north of Apache Trail	●5' for a 300' segment south of Superstition Boulevard	●76'
			●55' from 300' south of Superstition Boulevard to Gregory Street	●76'
			●55' from Gregory St to Apache Trail	●76'
Apache Trail	Broadway Avenue	●55' from Apache Trail to 4th Street ●None from 4th St to 220' north of Broadway Road ●10' from 220' north of Broadway Rd to Broadway Rd	●15'	●76' ●76' ●76'
			●55' Broadway Ave to 9th place	●76'
			●5' from 9th Place to 16th Avenue	
Broadway Avenue	Southern Avenue	●None North of Wier Ave ●55' South of Wier Ave to Puelo Ave ●None between Pueblo Ave to Southern Ave	●22' from 16th Avenue for 1/4 mile	●76'
			●5' from 1/4 mile south of 16th Street to Southern Avenue	
			●10'	
Southern Avenue	Baseline Road	●10'	●15'	●104'
Baseline Road	Guadalupe Road	●None	●65'	●104'
Guadalupe Road	Elliot Road	●None except for a 1/2 mile section south of Guadalupe Road where 10' is required	●65'	●104'
Elliot Road	Warner Road	●None except for a 1/4 mile section south of Mesquite St where 10' is required	●65'	●104'
Warner Road	Ray Road	●10' from Warner Rd to Starkey Ave ●None from Starke Ave to Ray Rd	●65'	●104'
Ray Road	Williams Field Road	●None	●65'	●104'
Williams Field Road	Pecos Road	●10'	●65'	●104'
Pecos Road	Germann Road	●None	●65'	●104'



## IX. Cost

Preliminary cost estimates for roadway construction and right-of-way acquisition were prepared for the corridor alternatives. This section summarizes the cost estimate for the recommended alternative, and the methodology used to develop the order of magnitude estimate. **Table 19** presents the order of magnitude cost estimate for the northern section of the corridor plus the alternatives for the southern section of the corridor. Detailed estimates for the corridor alternative may be found in *Working Paper #2: Evaluation Criteria and Plan for Improvements*.

**Table 19: Summary of Corridor Segment Estimates**

Phased Construction	Northern Section	Southern Section Alternatives			
		Alternative 1	Alternative 2	Alternative 3	Alternative 4
Near-Term	\$ -	\$ -	\$5,210,947	\$5,210,947	\$5,210,947
Mid/Long-Term	\$20,344,040	\$ -	\$25,613,040	\$28,956,720	\$25,613,040
Ultimate	\$ -	\$ -	\$11,394,480	\$12,524,640	\$11,394,480
<b>Total Cost (Northern plus Southern)</b>	<b>\$ -</b>	<b>\$ -</b>	<b>\$62,562,507</b>	<b>\$67,036,347</b>	<b>\$62,562,507</b>

The methodologies used to determine the quantity and costs for each item listed in the estimate are described below:

- Pavement – New pavement quantities were determined by multiplying the pavement width from the typical cross section of the proposed roadway by the total length of the corridor segment. The unit of measurement is square yards and the costs are based on recent ADOT construction bids.
- Earthwork and Drainage - A vertical alignment was not developed for the corridor with this study. Consequently, cost estimates for earthwork are based on length of roadway and anticipated terrain characteristics. The cost for Earthwork and Drainage were based on similar projects with a profile designed at or near existing grade. Earthwork percentage was 25% of new pavement costs while 15% of the new pavement costs were used to estimate Drainage costs.
- Structures – Based on size of structure needed to cross Powerline Floodway.
- Maintenance of Traffic, Lighting, Signing, Signals, Utilities, & Incidental Work – Costs for these items were based on a percentage of the subtotal generated from the items listed above.
- Right-of-Way Acquisition – Right-of-way costs of \$20,000 per acre (based on costs used in the *Signal Butte Corridor Improvement Study*, *Elliot Road Corridor Improvement Study* and *Meridian Road Access Control and Corridor Improvement Study*).
- Design and Construction Management – An estimate of 25 percent was used which include design and construction management.
- Contingency - An estimate of 25 percent of the total costs, including right-of-way acquisition, was used given the macro scale design effort of this corridor study.

**Table 20** presents the itemized cost estimate for the near-term improvements of the Meridian Road Corridor. **Table 21** and **Table 22** presents the itemized cost estimate for the northern segment of the Meridian Road Corridor between McDowell Boulevard and Southern Avenue for under the mid-term and long-term recommendations, respectively. **Table 23** and **Table 24** present the itemized cost

estimate for the southern segment's preferred Meridian Road Corridor between Southern Avenue and Germann Road under the mid/long-term and ultimate recommendations, respectively. The near-term, mid-term, long-term and ultimate phasing recommendations are described in further detail under the section titled *Phased Construction*.

**Table 20: Itemized Cost Estimate for Near-Term Recommendations**

Item	Item Description	Unit	Unit Price	Quantity	Total
-	(Segment Length)	MILES	-	2	-
1	New Pavement	SY	\$32.00	46934	\$1,501,888
2	Earthwork	LSUM	N/A	25% of Item 1	\$375,472
3	Drainage	LSUM	N/A	15% of Item 1	\$225,283
4	Structures	LSUM	\$500,000.00	0	\$ -
5	Maintenance of Traffic	LSUM	N/A	10% of Items 1-3	\$210,264
6	Lighting	LSUM	N/A	5% of Items 1-3	\$105,132
7	Signing/Signals	LSUM	N/A	15% of Items 1-3	\$315,396
8	Utilities	LSUM	N/A	5% of Items 1-3	\$105,132
9	Incidental Work	LSUM	N/A	15% of Items 1-3	\$315,396
<b>Total Construction Cost =</b>					<b>\$3,153,965</b>
10	ROW Acquisition	ACRE	\$20,000.00	16	\$320,000
11	Design & Construction Management	LSUM	N/A	25% of Item 1-10	\$868,491
12	Contingency	LSUM	N/A	25% of Item 1-10	\$868,491
<b>Order of Magnitude Project Cost =</b>					<b>\$5,210,947</b>

\*Cost excludes Meridian Road TI and Southern Avenue intersection improvements

**Table 21: Itemized Cost Estimate for the Northern Segment under Mid-Term Recommendations:  
McDowell Boulevard to Southern Avenue**

Item	Item Description	Unit	Unit Price	Quantity	Total
-	(Segment Length)	MILES	-	5.5	-
1	New Pavement	SY	\$32.00	129067	\$4,130,144
2	Earthwork	LSUM	N/A	5% of Item 1	\$206,507
3	Drainage	LSUM	N/A	15% of Item 1	\$619,522
4	Structures	LSUM	\$500,000.00	0	\$ -
5	Maintenance of Traffic	LSUM	N/A	10% of Items 1-3	\$495,617
6	Lighting	LSUM	N/A	1% of Items 1-3	\$49,562
7	Signing/Signals	LSUM	N/A	10% of Items 1-3	\$495,617
8	Utilities	LSUM	N/A	15% of Items 1-3	\$743,426
9	Incidental Work	LSUM	N/A	15% of Items 1-3	\$743,426
<b>Total Construction Cost =</b>					<b>\$7,483,821</b>
10	ROW Acquisition	ACRE	\$20,000.00	25	\$500,000
11	Design & Construction Management	LSUM	N/A	25% of Item 1-10	\$1,995,955
12	Contingency	LSUM	N/A	25% of Item 1-10	\$1,995,955
<b>Order of Magnitude Project Cost =</b>					<b>\$11,975,731</b>

**Table 22: Itemized Cost Estimate for the Northern Segment under Long-Term Recommendations:  
McDowell Boulevard to Southern Avenue**

Item	Item Description	Unit	Unit Price	Quantity	Total
-	(Segment Length)	MILES	-	5.5	-
1	New Pavement	SY	\$32.00	96214	\$3,078,848
2	Earthwork	LSUM	N/A	5% of Item 1	\$153,942
3	Drainage	LSUM	N/A	15% of Item 1	\$461,827
4	Structures	LSUM	\$500,000.00	0	\$ -
5	Maintenance of Traffic	LSUM	N/A	10% of Items 1-3	\$369,462
6	Lighting	LSUM	N/A	1% of Items 1-3	\$36,946
7	Signing/Signals	LSUM	N/A	10% of Items 1-3	\$369,462
8	Utilities	LSUM	N/A	15% of Items 1-3	\$554,193
9	Incidental Work	LSUM	N/A	15% of Items 1-3	\$554,193
<b>Total Construction Cost =</b>					<b>\$5,578,873</b>
10	ROW Acquisition	ACRE	\$20,000.00	0	\$ -
11	Design & Construction Management	LSUM	N/A	25% of Item 1-10	\$1,394,718
12	Contingency	LSUM	N/A	25% of Item 1-10	\$1,394,718
<b>Order of Magnitude Project Cost =</b>					<b>\$8,368,309</b>

**Table 23: Itemized Cost Estimate for the Preferred Corridor under Mid/Long-Term Recommendations:  
Southern Avenue to Germann Road**

Item	Item Description	Unit	Unit Price	Quantity	Total
-	(Segment Length)	MILES	-	7.5	-
1	New Pavement	SY	\$32.00	228800	\$7,321,600
2	Earthwork	LSUM	N/A	25% of Item 1	\$1,830,400
3	Drainage	LSUM	N/A	15% of Item 1	\$1,098,240
4	Structures	LSUM	\$500,000.00	1	\$500,000
5	Maintenance of Traffic	LSUM	N/A	10% of Items 1-3	\$1,025,024
6	Lighting	LSUM	N/A	5% of Items 1-3	\$512,512
7	Signing/Signals	LSUM	N/A	15% of Items 1-3	\$1,537,536
8	Utilities	LSUM	N/A	5% of Items 1-3	\$512,512
9	Incidental Work	LSUM	N/A	15% of Items 1-3	\$1,537,536
<b>Total Construction Cost =</b>					<b>\$15,875,360</b>
10	ROW Acquisition	ACRE	\$20,000.00	60	\$1,200,000
11	Design & Construction Management	LSUM	N/A	25% of Item 1-10	\$4,268,840
12	Contingency	LSUM	N/A	25% of Item 1-10	\$4,268,840
<b>Order of Magnitude Project Cost =</b>					<b>\$25,613,040</b>

**Table 24: Itemized Cost Estimate for the Preferred Corridor under Ultimate Recommendations:  
Southern Avenue to Germann Road**

Item	Item Description	Unit	Unit Price	Quantity	Total
-	(Segment Length)	MILES	-	7.5	-
1	New Pavement	SY	\$32.00	105600	\$3,379,200
2	Earthwork	LSUM	N/A	25% of Item 1	\$844,800
3	Drainage	LSUM	N/A	15% of Item 1	\$506,880
4	Structures	LSUM	\$500,000.00	1	\$500,000
5	Maintenance of Traffic	LSUM	N/A	10% of Items 1-3	\$473,088
6	Lighting	LSUM	N/A	5% of Items 1-3	\$236,544
7	Signing/Signals	LSUM	N/A	15% of Items 1-3	\$709,632
8	Utilities	LSUM	N/A	5% of Items 1-3	\$236,544
9	Incidental Work	LSUM	N/A	15% of Items 1-3	\$709,632
<b>Total Construction Cost =</b>					<b>\$7,596,320</b>
10	ROW Acquisition	ACRE	\$20,000.00	0	\$ -
11	Design & Construction Management	LSUM	N/A	25% of Item 1-10	\$1,899,080
12	Contingency	LSUM	N/A	25% of Item 1-10	\$1,899,080
<b>Order of Magnitude Project Cost =</b>					<b>\$11,394,480</b>

## X. Agency, Stakeholder and Public Involvement

This section documents the results of the interaction with affected agencies, stakeholders, and the general public during the Meridian Road Corridor Study. Additional information on agency, stakeholder and public involvement is available in **Appendix C**.

### Technical Advisory Committee

A Technical Advisory Committee (TAC) was established to solicit feedback from partnering agencies and key stakeholders at multiple stages of the corridor study. The following agencies are represented on this Committee:

- Pinal County
- City of Apache Junction
- City of Mesa
- Central Arizona Governments
- Maricopa County Department of Transportation
- FHWA
- ADOT Environmental Planning
- Maricopa County Flood Control District
- Town of Queen Creek
- Maricopa Association of Governments
- Arizona State Land Department
- Arizona Department of Transportation, Multimodal Planning Division
- Arizona Department of Transportation, Communications and Community Partnerships

Three separate TAC meetings were held over the course of the study. The first TAC meeting was held on May 16, 2012. The purpose of this meeting was to provide a general project overview, define the Planning and Environmental Linkages Program, discuss corridor specific issues, present the project schedule and solicit feedback from participating TAC members.

The second TAC meeting was held on November 14, 2012. The purpose of this meeting was to present *Working Paper #1: Existing and Future Conditions Inventory* and develop an approach to define the desired, future roadway classification, cross section and configuration for the Meridian Road corridor.

The third TAC meeting was held on February 26, 2013. The purpose of this meeting was to present *Working Paper #2: Evaluation Criteria and Plan for Improvements* and to review and address comments to finalize the report.

Meeting notes from the three TAC meetings are located in **Appendix E**.

### Stakeholder Coordination

Representatives from the TAC, Arizona State Land Department, Entellus and LTM Engineering met on a number of occasions to discuss the update to the East Mesa ADMP, along with coordination efforts between the two projects and how both projects will affect ASLD property. This effort culminated in a meeting on December 12, 2012 to discuss the various alternatives for both projects and how best to move forward. Following highlights the discussion of coordination and areas of consensus that were reached:



- Arizona State Land Department would prefer to keep the flood control facility adjacent to the roadway facility and would not favor a channel that meanders or jogs away from the roadway alignment;
- Interest was articulated in evaluating how a flood control facility could be designed to handle built-environment off-site drainage from Pinal County (specifically related to future development on State Land);
- Consensus was reached that the Meridian Road alignment should be on section line;
- Consensus was reached that the flood control facility (channel) should stay upstream (or east) of the Meridian Road corridor and that the Meridian Road Corridor Study can reference the forthcoming ADMP update to this point; and
- Consensus was reached that the combined footprint for the flood control and roadway facilities should be refined/reduced as much as possible.

Further separate coordination meetings were held with the various agencies/stakeholders to discuss the working papers and to provide input into existing and future development that could affect the corridor development.

### Public Outreach

Effective public participation facilitates understanding and improves decision making by providing a reasonable opportunity for all interested parties to provide input, identify issues and concerns and ensuring that this input informs the study's technical planning. Both the public and decision makers are given an opportunity to fully understand the problems, opportunities and available options for planning acceptable transportation solutions.

Tactics utilized for public outreach for the Meridian Road Corridor Study included the use of a survey instrument to garner feedback, a mailer was developed and sent to property owners adjacent to the corridor, a business walk was planned to hand deliver the information flier and to encourage businesses to take the on-line survey, distribution of fliers, and solicitation via partner communications (agency newsletters, social media, etc.). These tactics were used to obtain feedback on the following corridor topics:

- Opportunities, constraints and observations?
- Experience any problems?
- Agree/disagree: 6-lane divided arterial south of US 60 (Superstition Freeway)?
- Agree/disagree: 4-lane divided arterial between US 60 (Superstition Freeway) and Superstition Boulevard; 2-lane roadway north?
- Opportunities for non-motorized improvements and/or how would you utilize non-motorized improvements?
- Ideas for long-range plans?
- How often do you travel the corridor?
- Do you live/work/own property along the corridor?

## Public Meeting

A public meeting, held on May 16<sup>th</sup>, was conducted to present recommended (preferred) roadway type and corridor selection, a recommended timeline for the prioritization and construction of phased improvements, along with existing and future traffic data.

The public meeting was conducted in an "open house" format which provided a free, open and accurate exchange of information between area residents with specific issues or questions and the project team. The following agency and consultant representatives attended the public meetings:

- ADOT MPD: Charla Glendening
- City of Apache Junction: Giao Pham
- Pinal County: Doug Hansen
- Michael Baker: Simon Pratt and Mike Sabatini
- Planning for Strategic Action: Audra Koester Thomas

The majority of the comments received from the public were from residents of Sunland Springs Village which extends south from Baseline Road. The residents were concerned about the proximity of a new arterial four or six lane street adjacent to the sub-division wall. Consequently the majority of the comments centered on continuing the Meridian Road alignment south of Baseline Road east of the section line.

A Public Involvement Report was developed summarizing the outreach and feedback received and is included as part the **Appendix C** for this report.

## XI. Planning and Environmental Linkage (PEL)

The purpose of the Planning and Environmental Linkages (PEL) approach is to streamline the project development and environmental review process by improving coordination among stakeholders during planning and project-level decision-making. The PEL methodology encourages agencies to take an integrated, systems perspective to support transportation, environmental, and community goals. It allows agencies to better understand and agree to the purpose and need, define a reasonable range of alternatives and eliminate unreasonable alternatives, and begin the public involvement and the National Environmental Policy Act (NEPA) compliant documentation during the planning stage.

The overall goal of the PEL approach is to document certain activities in the planning process that can be used to inform project development by encouraging planning and environmental staff in transportation and resource agencies to share tools and improve coordination. When successfully implemented, the PEL approach makes the entire life cycle of a transportation project a more seamless process and more sensitive to environmental resources, from transportation planning to satisfying NEPA requirements to design, construction, and maintenance. It minimizes duplication of effort, reduces delays in transportation improvements, and results in a more environmentally sensitive project.

During the scoping meeting, the planning project partners reached an agreement on the level of detail that the corridor planning study should entail. The scoping material included identification and evaluation of such matters as:

- The project's purpose and need;
- Reasonable alternatives for the project; and
- The project's impacts on the environment.

An opportunity for public involvement was undertaken as well as strong participation from other agencies such as the City of Apache Junction, Pinal County, City of Mesa, Maricopa County and MAG along with resource agencies that have jurisdiction or an interest in the area of study. For those involved, the goal was to have early and meaningful involvement throughout the process.

Finally, the results and decisions of the planning process need to be documented in a way that is clear, suitable, and readily available for incorporation into the NEPA document. If a study or decision is to be used in a NEPA review, the study and the documented decision will need to be publicly available for those wishing to comment on the NEPA document, so it is important to maintain public access to the planning documents until the NEPA process is complete.

While planning studies, such as this corridor study, will generally not determine in detail what the impacts of a future project would be, these studies can be an effective basis for consideration of direct, indirect and cumulative impacts in NEPA analysis. As noted earlier, it is important for this corridor study to provide an overview of the planning area's current and future development patterns, growth, and demographics. By describing the interconnections between the transportation system, community resources, and the environment and natural ecosystem, this report will provide a baseline for measuring how the current environment will change and helps to identify what those changes may look like.

One of the main emphasis of this planning level study is to avoid and/or minimize environmental effects through the use of early screening as well as to start interagency discussions in advance on any mitigation agreements. By utilizing the analyses of both environmental data and transportation planning information, it was possible to screen planning-level decisions, such as the general travel corridor, for their impact on watersheds or habitat areas. Knowing the potential impact earlier will allow the involved agencies to develop more effective and economical mitigation strategies to meet both environmental and transportation objectives as the project progress through the next stages.

FHWA recommends documenting planning-level analysis that can be used to inform NEPA. One tool to accomplish this is the Planning/Environmental Linkages Questionnaire. The questionnaire is intended to:

- Inform planners about the requirements and options to consider while developing a planning study with a goal to inform the NEPA process; and
- Document and share relevant planning information with NEPA practitioners to build understanding about a project – both the information studied and areas that require more analysis.

The completed questionnaire will act as a summary of the planning process and it will ease the transition from planning to NEPA. The questionnaire is an adaptation of one developed by the Colorado Department of Transportation and FHWA Colorado Division Office. The questionnaire is included in **Appendix F**.

In addition to the questionnaire a checklist was developed to allow planning studies to progress through the NEPA process. The checklist was used as guidance at the beginning of and throughout the corridor planning process, and for confirmation at the end of the study.

# APPENDIX A

## WORKING PAPER #1: EXISTING AND FUTURE CONDITIONS INVENTORY

**Baker**

**Michael Baker Jr., Inc.**  
*Phoenix, Arizona*



September 2012

# Meridian Road Corridor Study

## Germann Road to McDowell Boulevard

### Working Paper #1

### Existing and Future Conditions Inventory

*Prepared for:*



PINAL • COUNTY

*Wide open opportunity*



*Prepared by*

**Baker**

**Michael Baker Jr., Inc.**  
*Phoenix, Arizona*

## Table of Contents

- I. Introduction ..... 4
- II. Study Area ..... 4
- III. Summary of Existing Plans and Studies ..... 7
  - Inventory ..... 7
  - General Findings and Recommendations ..... 8
    - Socioeconomic Data Compiled from Other Studies ..... 8
    - Roadway Characteristics of Meridian Road ..... 10
    - Summary of Transportation Issues Identified by Other Studies ..... 12
- IV. Existing Features Inventory ..... 15
  - Drainage Features ..... 15
  - East Mesa ADMP Structures Impacting Meridian Road ..... 19
  - Topography from Existing Sources ..... 20
  - Existing Utilities ..... 20
  - Recreation Trails, Parks/Areas, and Open Space ..... 24
  - Existing Access Management Conditions and Policy/Guidelines ..... 24
  - Existing Network and Roadway Classifications ..... 25
  - Existing Pavement Evaluation ..... 30
  - Existing Multimodal Transportation ..... 32
- V. Existing Socioeconomic Data ..... 32
  - Jurisdictions within the Corridor ..... 32
  - Existing Land Use ..... 32
  - Existing Zoning ..... 33
  - Land Jurisdiction and Ownership ..... 33
- VI. Existing Traffic Data ..... 37
  - Existing 2012 Traffic Volumes ..... 37
  - Existing 2012 Level of service ..... 41
  - Crash Data ..... 46
- VII. Environmental Summary ..... 48
  - Population Living within Study Area ..... 48
  - Environmental Justice ..... 48

Biotic Community..... 48

Wildlife ..... 49

Visual Character and Noise ..... 49

Water Resources ..... 50

Section 4(f) and Section 6(f) Properties ..... 50

Hazardous Materials ..... 50

Cultural Resources ..... 52

    Background Research ..... 52

    Windshield Survey..... 53

    Recommendations for Further Cultural Resource Work ..... 55

VIII. Future Conditions..... 55

    Flood Control District Channels ..... 55

    Future Recreation Trails, Parks/Areas and Open Space ..... 57

    Future Multimodal Transportation ..... 57

IX. Future Socioeconomic Data ..... 58

    Planned Land Use..... 58

    Future Land Development within the Corridor ..... 58

    Population and Employment ..... 59

X. Future Traffic Volumes..... 62

XI. Roadway Network Deficiencies ..... 71

    2025 Lane Deficiencies..... 71

    2035 Lane Deficiencies..... 71

    Pavement Deficiencies ..... 71

    Transportation Deficiencies ..... 71

**List of Figures**

Figure 1: Study Area ..... 6

Figure 2: Drainage Basins ..... 16

Figure 3: Existing FEMA Data ..... 17

Figure 4: Existing Drainage Features..... 18

Figure 5: General Topography ..... 21

Figure 6: Existing Utilities..... 22

Figure 7: Existing Number of Lanes..... 26

Figure 8: Posted Speed Limits ..... 27

Figure 9: Existing 2012 Intersection Lane Configuration and Control Type ..... 28

Figure 10: Existing FHWA Functional Classification ..... 29

Figure 11: Existing Land Uses ..... 35

Figure 12: Existing Land Ownership ..... 36

Figure 13: Existing 2012 Average Daily Traffic Volumes ..... 39

Figure 14: Existing 2012 Turning Movement Volumes ..... 40

Figure 15: 2012 Average Daily Level of Service ..... 43

Figure 16: Existing 2012 Intersection Level of Service ..... 45

Figure 17: Crash Location and Type ..... 47

Figure 18: Future Land Use ..... 61

Figure 19: 2025 Daily Traffic Volumes ..... 65

Figure 20: 2035 Daily Traffic Volumes ..... 66

Figure 21: Future 2025 Turning Movement Volumes ..... 67

Figure 22: Future 2035 Turning Movement Volumes ..... 68

Figure 23: 2025 Average Daily Traffic Level of Service ..... 69

Figure 24: 2035 Average Daily Traffic Level of Service ..... 70

**List of Tables**

Table 1: Summary of Collected Documentation ..... 7

Table 2: Existing Crossing Facilities within Study Area ..... 19

Table 3: Utility Stakeholders within the Meridian Road Corridor ..... 23

Table 4: Access Control Guidelines per Jurisdiction (for Urban Arterial Roads) ..... 25

Table 5: Existing Right-of-Way Widths ..... 30

Table 6: Current Pavement Condition Survey ..... 31

Table 7: Pavement Condition Rating ..... 31

Table 8: International Roughness Index ..... 31

Table 9: 2012 Average Daily Traffic Volumes ..... 38

Table 10: Level of Service Criteria for Urban Street Facilities ..... 41

Table 11: Summary of Generalized Annual Average Daily Volume Threshold Values by Facility Type ..... 42

Table 12: Level-of-Service Criteria for Signalized Intersections ..... 44

Table 13: Level-of-Service Criteria for Unsignalized Intersections ..... 44

Table 14: Leaking Underground Storage Tank Locations ..... 51

Table 15: Resource Conservation and Recovery Act (RCRA) Facilities ..... 52

Table 16: Summary of Previously Recorded Cultural Resources within the Study Area ..... 53

Table 17: Summary of Current Corridor Conditions ..... 54

Table 18: Project Influence Area Population Projections ..... 60

Table 19: 2025 and 2035 Daily Traffic Volumes ..... 63

## I. Introduction

The principal focus of the Meridian Road Corridor Study is to address the transportation planning needs identified by the jurisdictions and more particularly to lead the local jurisdictions to develop consensus on facility type, number of lanes and right-of-way requirements to guide the future development of the road. This could be memorialized through an intergovernmental agreement or a memorandum of understanding.

Pinal County is the local sponsor in cooperation with the City of Apache Junction. Meridian Road is a section line alignment road that is located on the boundary between Pinal County and Maricopa County. Pinal County, Apache Junction, Maricopa County, Queen Creek and Mesa all control portions of Meridian Road. They anticipate that future design and construction, particularly in the more developed areas, will depend upon federal funding. Therefore, this study will utilize the ADOT Planning and Environmental Linkages (PEL) process.

The proposed project is needed to support the continuing development and growth, occurring and anticipated, in the East Mesa, Apache Junction, and the San Tan Valley region. Significant growth is anticipated in this region that could result in population growth, economic development, and increased traffic volumes. The purpose of the Meridian Road Corridor Study is to evaluate the growing demands placed on local roads and streets by development in the region. The study will address the transportation planning needs identified by the jurisdictions and more particularly to lead the local jurisdictions to develop consensus on socio-economic demographic, modeling forecasts, roadway facility type, number of lanes, and right-of-way requirements to guide the future development of the road. The study will also include roadway improvement phasing plans, cost estimates and implementation plans. Additionally, the study will examine multimodal opportunities necessary to accommodate growth and development, such as, bicycle and pedestrian needs.

The purpose of this working paper is to document recent plans and current and future conditions in the project study area; build a solid foundation for the alternatives analysis; ensure consideration of all relevant information; develop an understanding of community objectives, opportunities and constraints; and identify any deficiencies in the study area.

## II. Study Area

The study area for the Meridian Road Corridor Study is approximately 13 miles in length and is generally bounded by Germann Road on the south, McDowell Boulevard on the north, Ironwood Road on the east and Signal Butte Road on the west. Meridian Road is a section line alignment road that is located on the boundary between Pinal County and Maricopa County. Pinal County, Apache Junction, Maricopa County, Queen Creek and Mesa all control portions of Meridian Road. Although Arizona State Land Department does not control portions of Meridian Road, ASLD does own a majority of the land to the east of Meridian Road, south of Baseline Road. Currently, Meridian Road is a discontinuous road within the study area. Meridian Road is a paved two-lane roadway from McDowell Boulevard to Baseline Road and between a half mile



north of Elliot Road and a half mile south of Warner Road. Meridian Road widens to provide a two-way left-turn lane between a half mile south of Lost Dutchman Boulevard and Superstitions Boulevard and a half mile north of Elliot Road to Warner Road. Meridian Road is a discontinuous dirt road within all remaining segments of the study area.

The study area is depicted in **Figure 1**.

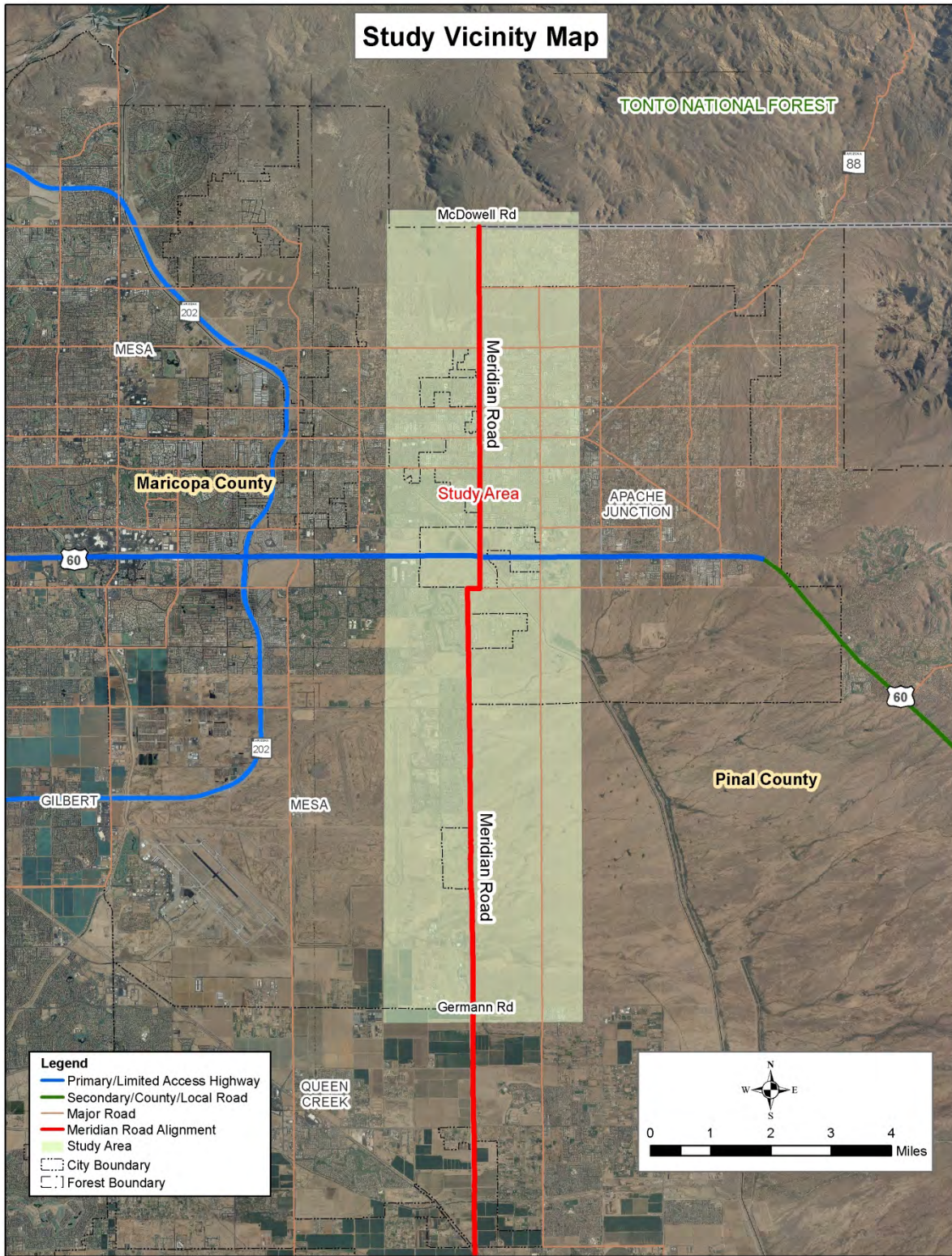

Figure 1: Study Area

### III. Summary of Existing Plans and Studies

Related plans, reports and studies completed during the last ten years were collected to compile available information and data pertinent to the Meridian Road Corridor Study. The purpose of this review is to gain an understanding of current issues and future plans within the study area. This chapter summarizes the available relevant information on existing and future conditions as contained in the plans, reports and studies collected.

#### Inventory

This section lists the reports and studies that were obtained and reviewed as part of the Meridian Road Corridor Study. **Table 1** provides a listing of the documents collected including document type, date completed, and agency/jurisdiction.

**Table 1: Summary of Collected Documentation**

Doc. Type	Jurisdiction Agency	Author/Originator	Document Title	Date
Report	Arizona Department of Transportation, City of Apache Junction	Jacobs	Apache Junction Transit Feasibility Study Update	Jun-12
Report	Arizona Department of Transportation, City of Apache Junction	Jacobs	Apache Junction Comprehensive Transportation Study	May-12
Report	Arizona Department of Transportation	HDR Engineering, Inc.	North-South Corridor Study Draft Purpose and Need	Dec-11
Report	Arizona Department of Transportation	N/A	Germann Road Corridor Improvement Study Power Road to Ironwood Road A Planning Assistance for Rural Areas Study Phase I Public Involvement Report	Dec-11
PARA Study Application	Arizona Department of Transportation	Pinal County	Meridian Road Corridor Study	Aug-11
Report	Arizona Department of Transportation	N/A	State Route 802, Williams Gateway Freeway Final Environmental Assessment and Appendices	Apr-11
Report	Arizona State Land Department	Robert Grow Consulting	Superstition Vistas: Final Report and Strategic Actions	Spring 2011
Exhibit	Arizona State Land Department	N/A	Pinal County (Superstition Vistas) Proposed Comprehensive Plan Amendment	May-11
Report	Arizona State Land Department	Jackie Guthrie & Associates	Superstition Vistas: Pinal County Comprehensive Plan Amendment	Jun-11
Memorandum	Arizona State Land Department	Robert Charles Lesser & Company, Inc.	Underlying Assumptions and Argument in Support of Household and Employment Growth Projections for Superstition Vistas Arizona State Trust Land	May-09
Report	Arizona State Land Department	Robert Grow Consulting	Superstition Vistas: Environmental Armature Concept Summary	Apr-09
White Paper	N/A	EDAW Inc.	Superstition Vistas Water Strategy White Paper	Apr-09
White Paper	N/A	Kimley-Horn and Associates, Inc.	Superstition Vistas Transportation Planning White Paper	N/A
White Paper	N/A	Fregonese Associates	Superstition Vistas White Paper: Land Use Scenario Development	Mar-09
Report	City of Mesa	HDR Engineering, Inc.	Mesa Gateway Strategic Development Plan: Transportation Analysis Memorandum	Jan-09
Report	City of Mesa	N/A	City of Mesa Transportation Plan	Jun-02
Plans	Flood Control District of Maricopa County; City of Mesa	Stanley Consultants, Inc.	Siphon Draw Improvements Phase 2	Apr-09
Plans	Flood Control District of Maricopa County; City of Mesa	Stanley Consultants, Inc.	Siphon Draw Improvements Phase 1	Jan-09
Plans	Maricopa County Department of Transportation	YSMA Transportation Engineering Solutions	Intersection Improvements of Southern Avenue and Meridian Road	Jul-11
Book of Summaries	Maricopa County Department of Transportation	N/A	2010 Maricopa County Department of Transportation Corridor Studies Book of Summaries	Jan-11
Report	Maricopa County Department of Transportation	EPS Group, Inc.	Signal Butte Corridor Improvement Study: US 60 to Rittenhouse Road	Dec-09
Memorandum of Understanding	Maricopa County Department of Transportation, City of Mesa	N/A	Memorandum of Understanding Between Maricopa County and the City of Mesa for Plan Review, Plan Approval, Permitting, Inspection, Construction, Annexation, Operation and Maintenance of Elliot Road from Power Road to Meridian Road	Aug-08
Report	Maricopa County Department of Transportation	Kimley-Horn and Associates, Inc.	Elliot Road Corridor Improvement Study: Power Road to the Central Arizona Project Canal	Jun-08
Report	Maricopa County Department of Transportation	URS	Meridian Road Access Control and Corridor Improvement Study	Jan-06
Report	Pinal County	Nygaard/Nelson Consulting Associates	Pinal County Transit Feasibility Study Final Report	Apr-11
Report	Pinal County	Lima & Associates	Regionally Significant Routes for Safety and Mobility	Dec-08
Report	Pinal County	Kirkham Michael Consulting Engineers	Pinal County Small Area Transportation Study Final Report	Aug-06



**Table 1 (continued): Summary of Collected Documentation**

Doc. Type	Jurisdiction Agency	Author/Originator	Document Title	Date
Report	Pinal County	Kirkham Michael Consulting Engineers	Pinal County Small Area Transportation Study Final Transit Element Report	Aug-06
Report	Town of Queen Creek	Cambridge Systematics, Inc.	Queen Creek Small Area Transportation Study	May-07

## General Findings and Recommendations

This section documents the findings and recommendations from existing studies and reports that are relevant to the study area.

### **Socioeconomic Data Compiled from Other Studies**

#### *Apache Junction Comprehensive Transportation Study (May 2012)*

The study states that the City of Apache Junction has experienced a population growth rate of 1.41% per year from 2000 to 2010, which is lower than the average statewide growth rate of 2.46% per year and significantly lower than the Pinal County growth rate of 10.91% per year. Housing unit growth rates between 2000 and 2010 in the City of Apache Junction were 0.31% per year, which is lower than the average statewide rate of 2.99% per year and significantly less than the Pinal County rate of 9.62% per year. (Page 7)

The study mentioned that the proposed Portalis Master Plan Community, a 7,700-acre master-planned community in Superstition Vistas, will have a large impact on the future growth of the City of Apache Junction. If the Portalis Master Plan Community becomes a reality the population of the City could more than double; however, development time frames for this area are uncertain. (Page 42)

#### *Mesa Transportation Plan (June 2002)*

The most recent transportation plan for the City of Mesa was completed in 2002. The Mesa Transportation Plan discusses all transportation issues affecting the City of Mesa and the implementation of the transportation plan expected to occur in phases between 2000 and 2025. The study states that the traffic volume growth within the City of Mesa from 1994 to 2000 ranges from 3% in the western part of the City to 59% in east Mesa. The largest percent increases occurred in east Mesa and south of US 60. (Page 4-6)

#### *Elliot Road Corridor Improvement Study (June 2008)*

The Elliot Road corridor encompasses Elliot Road alignment between Power Road and the Central Arizona Project (CAP), extending past Meridian Road. The study shows the existing (2006) and project future (2015 and 2030) population and employment in the Elliot Road corridor. The annual population and employment growth rates along the Elliot Road corridor between 2006 and 2015 are 6.0% and 19.7%, respectively. The annual population and employment growth rates along the Elliot Road corridor between 2006 and 2030 are 5.1% and 11.2%, respectively. (Page 15)

#### *Pinal County Small Area Transportation Study (August 2006)*

This study cites an 11% annual growth rate in population between 2005 and 2025 within Pinal County with most of the county's population located in the north central portion of the county.

(Page 48) A 13% annual increase in employment is anticipated to occur between 2005 and 2025 within Pinal County with most of the county's employment located in the western portion of the county. (Page 52)

*North-South Corridor Study, Draft Purpose and Need (December 2011)*

This study cited population projections for Maricopa, Pima and Pinal Counties between 2010 and 2050 at 100%, 103%, and 462% change, respectively. Employment projections for Maricopa, Pima and Pinal Counties between 2009 and 2050 result in a 132%, 87% and 850% change, respectively. Finally, population and employment projections for the North-South Corridor between 2005 and 2050 result in a 832% and 3,927% change, respectively. (Page 12-13)

*Meridian Road Corridor Study (August 2011)*

The study cited that the MAG Regional Transportation Plan indicated that Meridian Road from Baseline Road to Germann Road would be constructed under Phase 3 (Years 2016-2020), a traffic interchange at Meridian Road/US 60 would be constructed under Phase 2 (Years 2011-2015) and Williams Gateway Freeway from the State Route 202 (SR 202L) to Meridian Road would be constructed under Phase 3 (Years 2016-2020) of the Plan. (Page 2-14)

*Superstition Vistas Final Report and Strategic Actions (Spring 2011)*

Superstition Vistas comprises of approximately 175,000 acres of undeveloped land. The land is held in trust by the Arizona State Land Department and is managed for beneficiaries, the public schools and other state public institutions. (Page 13)

There are six possible scenarios for the Superstition Vistas area. All scenarios assume that one million people would occupy the Superstition Vistas area (Page 4)

*Mesa Gateway Strategic Development Plan: Transportation Analysis Memorandum (January 2009)*

The Phoenix-Mesa Gateway Airport is expected to become a major East Valley employment center. The vision of the Mesa Gateway Strategic Development Plan is to attract 100,000 high wage/high value jobs, create a financially sustainable area, protect and promote the airport, and create a live, work, play community. The preferred land use concept includes 36,100 households and 165,700 of employment. The land use concept and traffic projections take into account the expansion of the Arizona State University Polytechnic Campus and a residential and commercial mixed-use development planned on the site of the former General Motors Proving Grounds. (Pages 24-32)

*Pinal County Transit Feasibility Study (April 2011)*

Between 2000 and 2007, Apache Junction's population grew from 32,000 to nearly 37,000. In addition to the City's year-round residents, the city estimates that it also has over 40,000 winter residents, many of whom are seniors. The city is largely residential, and has a very large proportion of mobile homes (50% of all housing units) and second homes (up to 40%). The city also has a significant number of adult-only communities. (Page 3-3)



The study mentioned that Pinal County is still sparsely developed, and most new development has been large-scale residential communities. The number of major activity centers within the county is limited. The commercial district along Apache Trail and the Walmart in Apache Junction are included in the list of major activity centers with Pinal County. (Page 3-15)

### **Roadway Characteristics of Meridian Road**

#### *Meridian Road Corridor Study (August 2011)*

Meridian Road is proposed to be a full six-lane facility with a right-turn lane and a left-turn lane in each direction at the arterial intersections. In addition, bike lanes in each direction are proposed, along with sidewalks, curb and gutters, shoulder landscaping and raised landscaped median. The study limits begin at Empire Boulevard and end at Southern Avenue. (Page viii)

Meridian Road is proposed to be a full six-lane facility up to the intersection with Southern Avenue with the northbound outside third lane serving as a dedicated right-turn lane at Southern Avenue. A full access traffic interchange at US 60 is also proposed. It was recommended to shift the section line alignment westward beginning just south of US 60 and tie into the existing section line at the intersection with Baseline Road. A meandering section line alignment from Baseline Road to Empire Boulevard was recommended to optimize the use of existing right-of-way and to avoid impacts to existing facilities. Finally, a single point urban interchange (SPUI) is recommended for the future Williams-Gateway Freeway. (Pages 7-1 – 7-12)

#### *Apache Junction Comprehensive Transportation Study (May 2012)*

The study listed several short term improvements needed to meet the traffic demand as the study area reached a population of 60,000. These improvements included:

- Half diamond interchange at US 60 and Meridian Road;
- Widen Meridian Road to four lanes from Broadway Road to Baseline Road;
- Intersection improvements at Southern Avenue and Meridian Road; and
- US 60 and Meridian Road Bridge rehabilitation. (Page 43)

The study listed several midterm improvements needed to meet the traffic demand as the study area reached a population of 75,000. These improvements included extending Meridian Road south of Baseline Road to the Apache Junction city limits as a four-lane roadway. The study recommends that the extension of Meridian Road as a four-lane roadway south of the city limits to Hunt Highway to improve capacity within the project influence area. (Page 64)

The study listed several long term improvements needed to meet the traffic demand as the study area reached a population of 130,000. These improvements under the preferred alternative included widening Meridian Road to six lanes between Apache Trail and Baseline Road. (Page 49-50)

#### *Elliot Road Corridor Improvement Study (June 2008)*

The preferred alternative for the Elliot Road Corridor recommended in this study places the right-of-way centerline for the new typical cross-section on the existing roadway centerline.

This will result in an offset in Elliot Road at Meridian Road of more than 300 feet due to the existing section lines not lining up across the Maricopa/Pinal county line. The preferred Elliot Road Corridor alternative includes a 10,000-foot radius reverse curve that will not require superelevation, avoids an existing drainage wash, and aligns better with the planned Lost Dutchman Heights development roadway network and Siphon Draw Wash drainage basin. (Pages 47-49) Ultimately, once the City is built out, Meridian Road will be widened to a six-lane roadway from Apache Trail to Superstitions Boulevard. (Page 120)

#### *Signal Butte Road Corridor Improvement Study (December 2009)*

The study stated that on April 15, 2009, the Town of Queen Creek approved a general plan amendment that called for a realignment of Signal Butte Road and Meridian Road to consolidate the two transportation corridors between Queen Creek Road and Ocotillo Road. By combining the two transportation corridors, it will eliminate the need for a railroad crossing on Signal Butte Road and could expedite the development of a needed north-south corridor within the area. (Page 13)

#### *Mesa Transportation Plan (June 2002)*

The Mesa Transportation Plan was completed in June 24, 2002. This study recommended the construction of the Williams Field Freeway (now called SR 24), a 6-lane parkway, from SR 202L to Meridian Road within 6 to 10 years. (Page 4-36) The construction of Elliot Road from Ellsworth Road to Meridian Road as 6-lane arterial and widening of Guadalupe Road and Baseline Road from Ellsworth Road and Meridian Road is recommended within 11 to 15 years. (Page 4-37) The construction of McKellips Boulevard from Sossaman Road to Meridian Road, Warner Road from Ellsworth Road to Meridian Road, Pecos Road from Power Road to Meridian Road and Signal Butte Road from Broadway Road to Warner Road as 6-lane arterial roadways and the widening Southern Avenue from Ellsworth Road to Meridian Road and Signal Butte Road from Main Street to Broadway Road is recommended within 16 to 20 years. (Page 4-38) Finally, the construction of Meridian Road from Baseline Road to Germann Road and Signal Butte Road from Warner Road to Germann Road as 6-lane arterial roadways and the construction of Brown Road from Ellsworth Road to Meridian Road and Signal Butte Road from McKellips Road to University Drive as 4-lane arterial roadways is recommended within 21 to 25 years. (Page 4-39)

The study recommended future transit improvements including a local bus route along Signal Butte Road from Baseline Road to Pecos Road, an express bus route along US 60, a Transit Priority Corridor/BRT Line along Main Street, and recommends future service expansion as demand warrants within the area between US 60 and Germann Road and between Ellsworth Road and Meridian Road. (Page 5-25)

Future bicycle lanes are recommended along Meridian Road from Baseline Road to Germann Road and along every major crossroad from Brown Road to Germann Road. (Page 6-7)

### *Pinal County Small Area Transportation Study (August 2006)*

This study cites recommended improvements to include:

- All regionally significant routes as 6-lane major arterial facilities and
- All state highways as 4-lane roadways except for the following, listed below:
  - Widen US 60 from SR 79 to Pinal/Gila County Line to 6 lanes;
  - Widen SR 347 from I-10 to SR 84 to 6 lanes;
  - Widen SR 287 from SR 79 to proposed North-South freeway to 6 lanes; and
  - Widen SR 79 from US 60 to Pinal/Pima County line to 6 lanes. (Page 63)

This study recommends adding an additional north-south roadway corridor to alleviate future congestion anticipated from new economic developments planned for the north central study area. The additional roadway should be a 6-lane major arterial to accommodate the increase in traffic volumes and congestion that are expected in the area bounded by Williams Gateway, SR 79, SR 287 and Hunt Highway. (Page 75)

### *Queen Creek Small Area Transportation Study (May 2007)*

The study shows improvements to the roadway network including a modified expressway connecting to the Williams Gateway Freeway at Meridian Road, a limited set of arterial improvements, widening of the Williams Gateway Freeway from Meridian Road to SR 202L, and an additional connector from Queen Creek Road to Germann Road just west of Hawes Road. (Page 3-4)

This study identified additional projects as part of the small area transportation study including improvements to Meridian Road from Germann Road to Riggs Road. The study classifies this section of Meridian Road as a high capacity facility or an access-limited facility. It is believed that by adding one high capacity facility, traffic on the arterial system can be reduced by 35%. Development of this road requires completion of the segment of Meridian Road within Mesa from the Williams Gateway Freeway to Germann Road and a potential southeast extension of this route into Pinal County. (Page 5-4)

## **Summary of Transportation Issues Identified by Other Studies**

### *Meridian Road Corridor Study (August 2011)*

The highest traffic volumes along Meridian Road are in the southern portion of the study area with 2030 average daily traffic of 30,000 to 60,000 vehicles per day between Williams Field Road and Empire Boulevard (Page 3-10).

The study cites that as a six-lane facility, the Year 2030 daily volume on Meridian Road is projected to exceed six-lane planning level volume threshold of 45,000 vehicles per day south of the intersection with Riggs Road/Combs Road. (Pages 3-13 – 3-14)

The study states that minimal existing right-of-way along Meridian Road has been dedicated. As a result, more than 65 feet of the right-of-way may be needed on one side of Meridian Road in some areas to accommodate the recommended alignment. (Page 8-11)

*Apache Junction Comprehensive Transportation Study (May 2012)*

The study showed that under no build conditions and population projections at 75,000, Meridian Road is anticipated to operate at a level of service C and D south of Southern Avenue. (Page 48) Under no build conditions and population projections at 130,000, Meridian Road is anticipated to operate at a level of service C and D south of Apache Trail with the segment between Southern and Baseline operating at a level of service E and F. (Page 52)

Under the preferred alternative (includes widening Meridian Road between Apache Trail and Baseline Road to six lanes) when the population within the study area reaches 130,000, the highest traffic volumes along Meridian Road are between Southern and US 60 at greater than 30,000 vehicles per day (Page 91). Level of service is anticipated to be at A and B for entire segment of Meridian Road under the preferred alternative. (Page 92)

The study recommends a local bus route along Meridian Road between Superstition Boulevard and Baseline Road when the population within the study area reaches 130,000. (Page 113)

*Apache Junction Transit Feasibility Study Update (May 2012)*

The study listed a “starter” service to be implemented to meet traffic demands as the study area reaches a population of 60,000. This “starter” route serves an area of the City that has the highest combined residential and employment densities, together with regional commuter services the City with Valley Metro. The route would provide service to the area bounded by Apache Trail to the north, Southern to the south, Delaware Drive to the west and SR 88 to the east. (Pages 78-81)

The study proposed several additional routes to be added to the area to meet traffic demand as the population reaches 75,000. These routes are proposed along Idaho Road and Baseline Road, Ironwood Drive and Meridian Road. The City of Apache Junction is proposing a local bus route along Meridian Road from University Drive/Superstition Boulevard to Broadway Avenue. This transit route would provide additional service to the area bounded by Meridian Road to the west, Apache Trail to the north, Ironwood Road on the east, and Baseline on the south that has a high combined residential and employment density. Wal-Mart, the County/DMV office, City Hall, mixed use center and a transit hub are significant trip generators located along the proposed route. (Pages 81, 84-90)

The study proposed several additional routes and an expansion of a previously proposed route to meet traffic demands at the population reaches 130,000. The new routes proposed will provide service along Idaho Road and Southern Avenue as well as Apache Trail, Old West Highway and Tomahawk Road. Additional service was proposed along Meridian Road between Broadway Avenue and Baseline Road. (Pages 91-98)

*Elliot Road Corridor Improvement Study (June 2008)*

The study shows 2030 average daily traffic (ADT) along Elliot Road west of Meridian Road at 29,500 vehicles per day and 23,600 vehicles per day east of Meridian Road based on 2030 MAG model outputs. 2030 average daily traffic along Meridian Road north of Elliot Road is

anticipated to be 14,600 vehicles per day and 25,600 vehicles per day south of Elliot Road based on 2030 MAG model outputs. Discrepancies between the 2030 MAG model and other travel demand models along the eastern portion of the study area resulted in an alternate set of 2030 ADT's. The alternate set of 2030 ADT's showed 40,400 vehicles per day and 32,300 vehicles per day along Elliot Road west and east of Meridian Road, respectively, and 38,900 vehicles per day and 48,400 vehicles per day along Meridian Road north and south of Elliot Road, respectively. (Pages 22-23)

#### *Signal Butte Road Corridor Improvement Study (December 2009)*

The highest traffic volumes along the Signal Butte Road corridor are south of Germann Road ranging between 37,000 vehicles per day and 52,000 vehicles per day. Due to the realignment of the Signal Butte Road and Meridian Road corridors, the traffic volumes along Meridian Road north of Ocotillo Road to SR 802 (SR 24) are anticipated to decrease significantly and the volumes along Signal Butte Road north of Queen Creek Road to SR 802 (SR 24) are anticipated to increase. (Pages 14-15)

#### *Mesa Transportation Plan (June 2002)*

The highest traffic volumes along Meridian Road are between Baseline Road and Warner Road ranging between 25,000 vehicles per day to 30,000 vehicles per day. (Page 4-19)

#### *Pinal County Small Area Transportation Study (August 2006)*

The highest traffic volumes along Meridian Road are located between State Route 802 (SR 802) and Hunt Highway ranging from 38,000 vehicles per day and 68,000 vehicles per day. (Page 76) Level of service along Meridian Road is anticipated to be at a LOS of C or better except at the following locations:

- The segment between Broadway Road to Southern Avenue is anticipated to operate at a LOS D;
- The segment between Southern Avenue and US 60 is anticipated to operate at a LOS F;
- The segment between US 60 and Baseline Road is anticipated to operate at a LOS E;
- The segment between Queen Creek Road and Combs Road is anticipated to operate at a LOS D; and
- The segment between Combs Road and Hunt Highway is anticipated to operate at a LOS F. (Page 67)

#### *Pinal County Transit Feasibility Study (April 2011)*

The study cited that in 2006, the largest volume of travel for all trip purposes was between Pinal County and Maricopa County. The majority of these were from Apache Junction at 99,000 per day. The largest numbers of trips between areas within Pinal County are from Eloy, Maricopa, and Coolidge to Casa Grande, and from Florence to Coolidge. The largest flows to Pima County are from the Oracle area.

For work trips, the highest travel flows are also from Pinal County to Maricopa County. The largest of these are from Apache Junction at 20,000 per day. The largest work trip flows within Pinal County are to Casa Grande: 10,000 per day from Maricopa (which is the same level as to



Maricopa County) 8,000 per day from Eloy, and 6,000 per day from Florence. Given the popular success of Maricopa Xpress, these flows indicate that at the present time, commuter services could be feasible between Apache Junction and Maricopa County, between Maricopa and Casa Grande, and Eloy and Casa Grande. (Page 3-19)

There is already significant demand for transit from Apache Junction to Maricopa County, and over the next 15 years, work trip travel volumes will quadruple. In addition, work trip travel volumes from Maricopa County to Apache Junction will grow to almost as high as from Apache Junction to Maricopa County. Potential transit improvement includes the extension of Valley Metro services across the county line into Apache Junction to provide connections to and from the Phoenix area, and/or dedicated services between Apache Junction and Maricopa County. There will also likely be demand for service between Apache Junction and Florence. (Page 4-10)

## IV. Existing Features Inventory

The following sections provide an inventory of existing features within the study area.

### Drainage Features

Existing drainage features within the study corridor include several watersheds, floodplain, washes, flood control projects, bridges, culverts, low water crossings and the Central Arizona Project (CAP) Canal which crosses at US 60. Runoff throughout the area generally flows from northeast to southwest. Meridian Road, from McDowell Boulevard south, is generally the boundary between Maricopa County and Pinal County. Watershed runoff that originates in Pinal County flows into Maricopa County, crossing Meridian Road. All existing flood control projects along the Meridian Road project corridor belong to the Flood Control District of Maricopa County (FCDMC), with intent to mitigate flooding impacts of upstream watersheds on Maricopa County property.

**Figure 2** shows the watersheds that are bisected by Meridian Road. These watersheds include:

- Bulldog Wash – Buckhorn Mesa FRS
- Town of Apache Junction – Roosevelt Canal
- Siphon Draw
- Dinosaur Mountain-Roosevelt Canal
- Middle Queen Creek
- Peralta Canyon
- Apache Land Tank

**Figure 3** shows the FEMA watershed that impact Meridian Road. These floodplains include seven Zone A floodplains and one Zone AH floodplain.

**Figure 4** shows all existing crossing facilities within the project corridor. These crossings are identified in **Table 2** and include three FCDMC Projects: Signal Butte Flood Retarding Structure (FRS) and Floodway, the Siphon Draw Drainage improvements, and the Powerline FRS and Floodway.

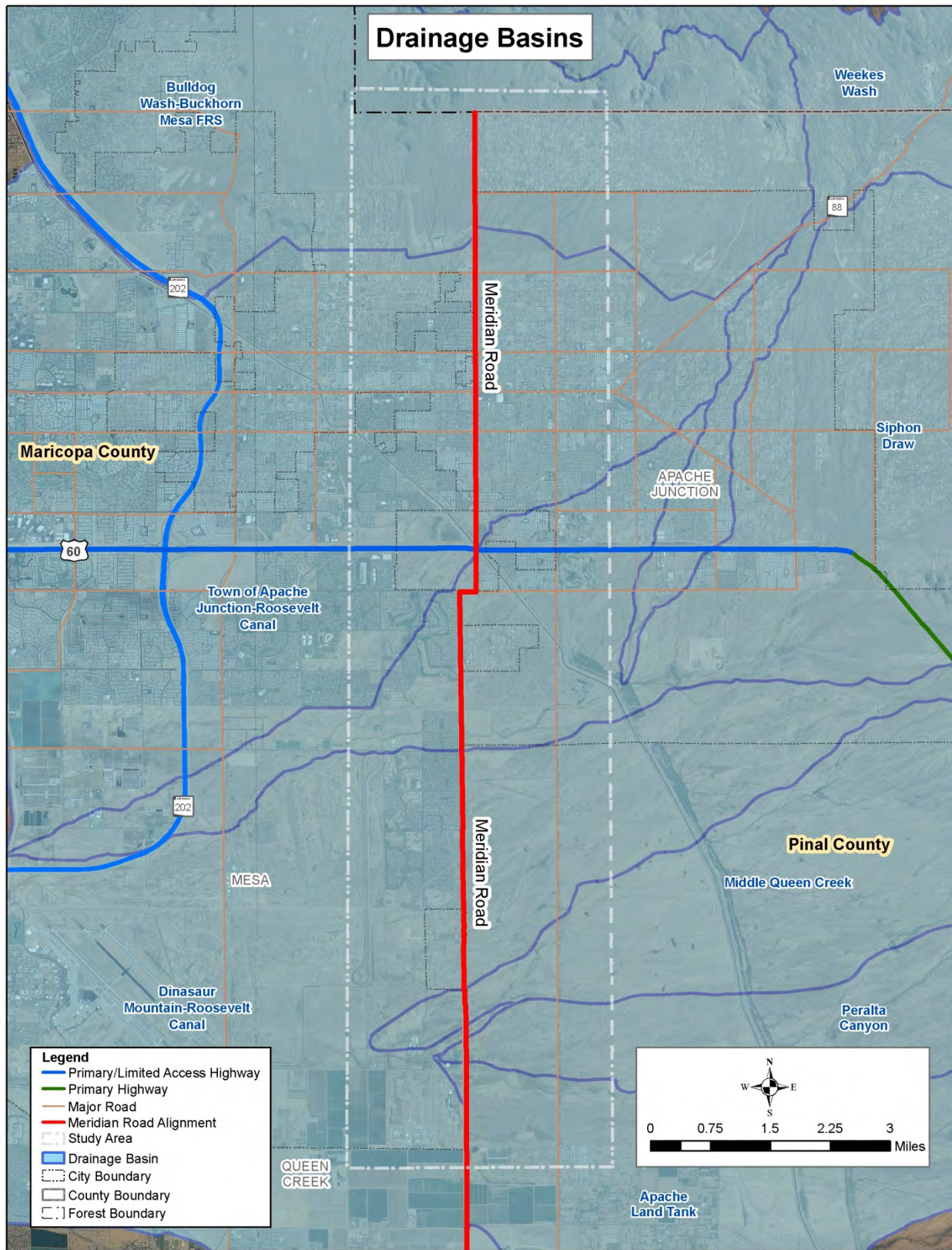
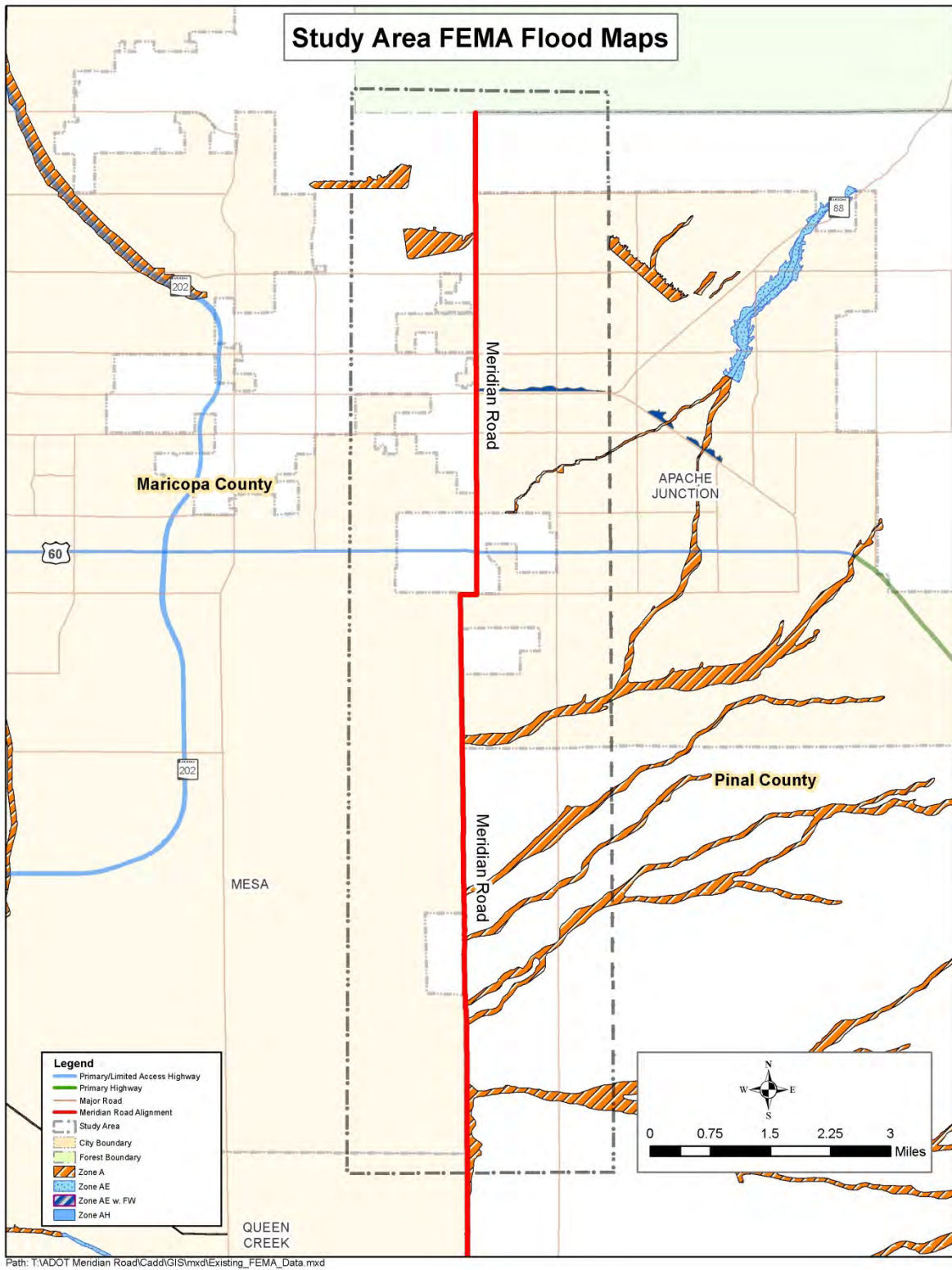

Figure 2: Drainage Basins





**Figure 3: Existing FEMA Data**

(The area west of Meridian Road and south of US 60 is located on unmapped, unprinted FEMA FIRM panels, and thus contains no delineated floodplains.)



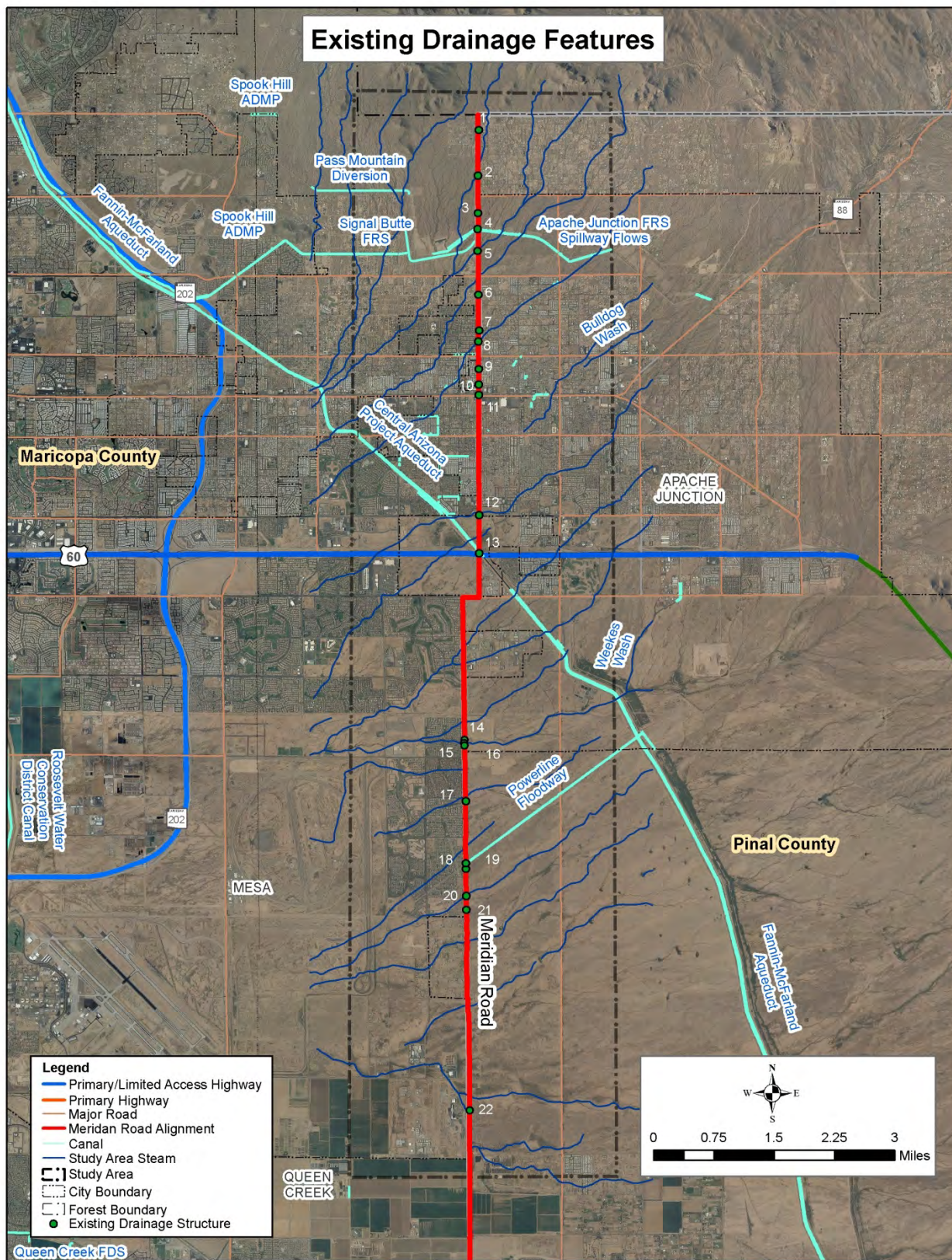

Figure 4: Existing Drainage Features

**Table 2: Existing Crossing Facilities within Study Area**

Crossing No.	Structure	Description	Location
1	18" RCP	existing cross-drainage	0.2 miles south of McDowell Blvd.
2	3-8' x 4' RCBC's	existing cross-drainage	0.1 miles north of Whiteley St.
3	Low Water Crossing	existing cross-drainage	0.2 miles south of McKellips Blvd.
4	Bridge (50' x 8.5')	Signal Butte FRS & Floodway	Flood Control Project: 0.43 miles south of McKellips Blvd.
5	4-48" CMP's	existing cross-drainage	0.3 miles north of Brown Rd.
6	2-40" x 30" CMP Squash	existing cross-drainage	@ Foothill St.
7	24" RCP	existing cross-drainage	Manzanita St.
8	10' x 3' RCBC	existing cross-drainage	0.04 miles north of Greasewood St.
9	Low Water Crossing	existing cross-drainage	channel between Happy Days Park and D Ave
10	Low Water Crossing	existing cross-drainage	A Ave
11	18" CMP	existing cross-drainage	Median of Main St./ Apache Trail
12	Low Water Crossing	existing cross-drainage	0.2 miles north of US 60
13	Bridge	CAP Canal	US 60
14	2-10' x 4' RCBC's	Siphon Draw Drainage Improvements	Flood Control Project: 0.07 miles north of Pronghorn Ave.
15	10' x 3' RCBC	existing cross-drainage	0.01 miles north of Pronghorn Ave.
16	2-24" RCP's	existing cross-drainage	0.05 miles south of Pronghorn Ave.
17	2-10' x 4' RCBC's	existing cross-drainage	0.04 miles south of Mesquite St.
18	4-10' x 4' RCBC's	existing cross-drainage	0.09 miles south of Segura Ave.
19	Bridge	Powerline FRS & Floodway	Flood Control Project: 0.11 miles south of Segura Ave.
20	Low Water Crossing	existing cross-drainage	0.23 miles south of Starfire Ave.
21	36" RCP	existing cross-drainage	0.09 miles north of Ray Rd.
22	Diversion Dike	existing cross-drainage	0.46 miles south of Pecos Rd.

### East Mesa ADMP Structures Impacting Meridian Road

The purpose of an Area Drainage Master Plan (ADMP) is to identify existing flood-prone areas as well as projections of future conditions. Several existing and proposed detention basins, cross culverts, and collector channels identified in the East Mesa ADMP directly impact the Meridian Road corridor and are summarized below:

#### *Signal Butte:*

Signal Butte Flood Retarding Structure (FRS) is an earth-fill dam with a geo-membrane which is part of the Buckhorn-Mesa system. The Signal Butte FRS is 1.3 miles in length and has a height of 39 feet, with a storage capacity of 1620-acre feet. It is situated 100 feet to the west of Meridian Road north of Brown Road/Lost Dutchman Boulevard. Any impact to the geo-membrane would be a fatal flaw for the Flood Control District. There is a maintenance road running alongside the dam which would need to be maintained at all times if Meridian Road is constructed or reconstructed. Any impact to the dam would require the involvement of Arizona Department of Water Resources (ADWR) and National Resources Conservation Service (NRCS) as well as the Flood Control District of Maricopa County.

#### *Bulldog Floodway:*

Part of the Signal Butte FRS, the channel crosses Meridian Road approximately a half mile north of Brown Road/Lost Dutchman Boulevard. The flow in this channel is not supercritical which would allow for the placement of new piers if the new structure was required to carry Meridian Road over the floodway. Access to the floodway is from Meridian Road which would need to be maintained at all times during any construction or reconstruction of Meridian Road.



#### *Sunland Springs Channel and Siphon Draw Detention Basin:*

The Siphon Draw Detention Basin is located east of Meridian Road in Pinal County and north of the Elliot Road alignment. The Sunland Springs Channel follows the Meridian Road alignment north of the Siphon Draw Basin. These facilities convey runoff reaching the site from two the Central Arizona Project (CAP) over chutes and intercept runoff at the Pinal County line (Meridian Road alignment). The Siphon Draw Detention Basin collects channelized runoff and runoff from Siphon Draw and attenuates flows to allow a reduction in the size of downstream improvements. The Sunland Springs Channel which runs along the east side of Meridian Road is a concrete lined channel with eight drop structures extending 6,800 feet north of the Siphon Draw Basin. The channel acts as a flow-by system that discharges excess flows into the basin through a side channel spillway. The Siphon Draw Basin collects the overflow from the Sunland Springs Channel and from two additional locations.

#### *Powerline Floodway:*

Powerline Flood Retarding Structure (FRS) is the northern-most of a system of three flood control structures (Powerline FRS, Vineyard Road FRS and Rittenhouse FRS) running parallel to the CAP between the Baseline Road and Ocotillo Road alignments in Pinal County. Despite being located in Pinal County, the structures primarily provide flood protection for downstream portions of Maricopa County. Powerline FRS conveys storm water runoff to the Powerline Floodway which crosses Meridian Road a half mile south of Warner Road and outfalls at the East Maricopa Floodway. No structural impacts will be permitted to the Floodway. Any new bridge will require a clear span in order not to affect the supercritical flow in the channel. The Natural Resources Conservation Service (NCRS) will need to permit any construction impacts to the Floodway.

### **Topography from Existing Sources**

The topography along the Meridian Road alignment falls generally to the south. Approximately 15 unnamed washes are identified as crossing Meridian Road within the project limits. Additionally, Weekes Wash and Siphon Draw Wash combine upstream of Meridian Road and cross at one location. The average slope of the Meridian Road alignment varies along the corridor and is steeper in the northern section. **Figure 5** illustrates the general topography within the study area.

### **Existing Utilities**

Arizona Blue Stake was contacted to identify the utility stakeholders within one mile either side of the study area. **Figure 6** illustrates the existing utilities within the study area. **Table 3** contains a list of the utility owners and utility types identified by Blue Stake within the study area.

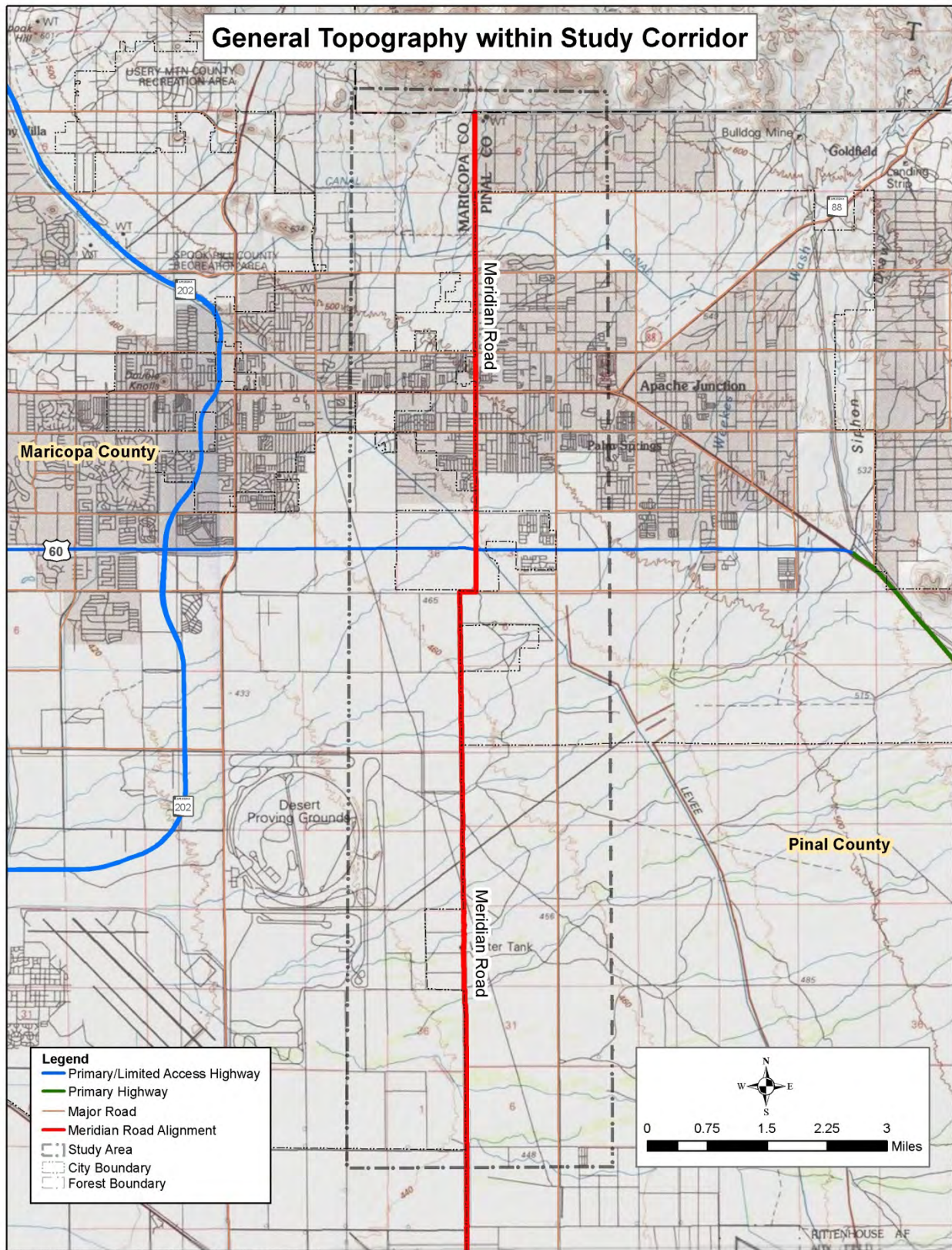

Figure 5: General Topography



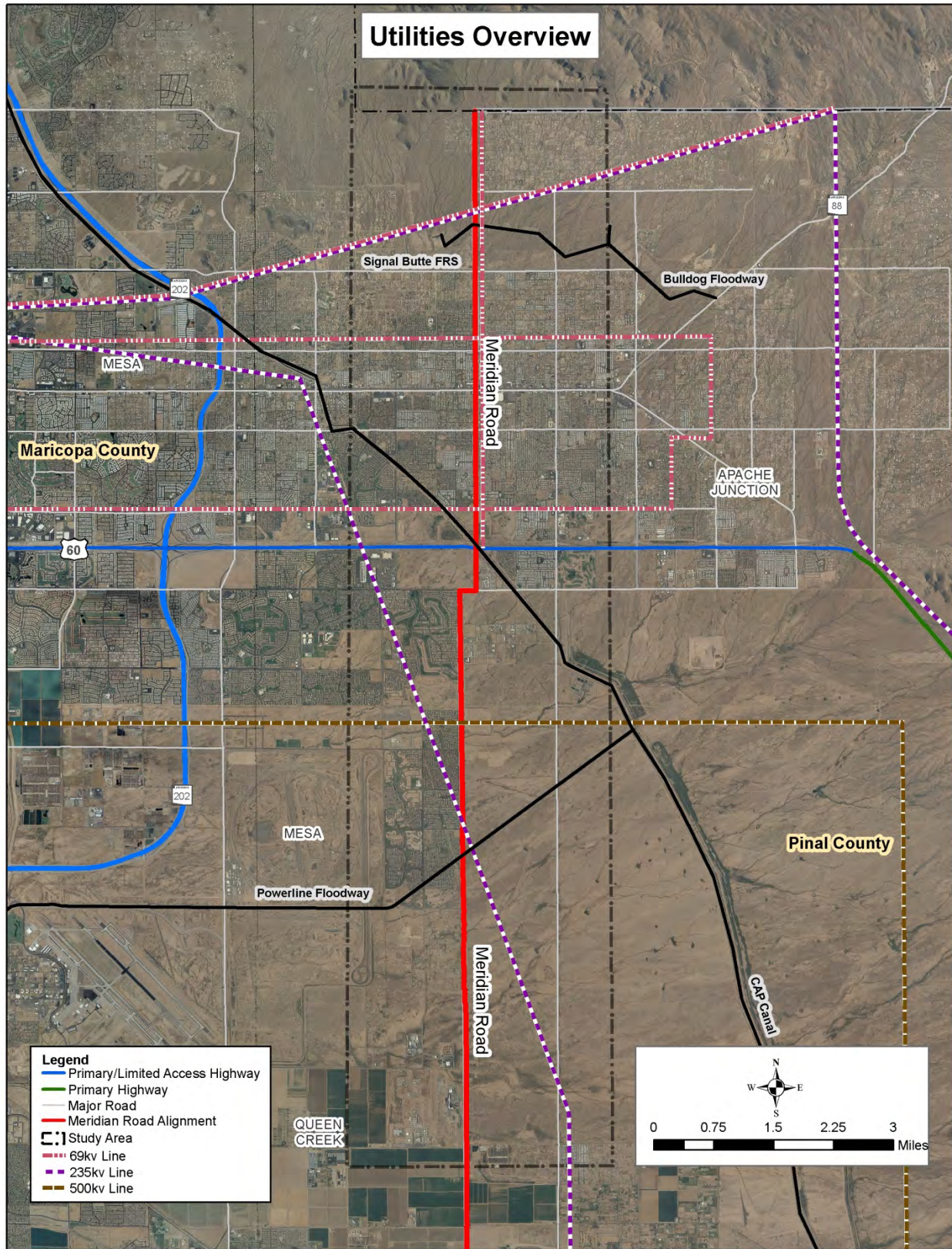

Figure 6: Existing Utilities

**Table 3: Utility Stakeholders within the Meridian Road Corridor**

Utility Company	Type of Facility
Salt River Project (SRP)	Communication, Electrical, Irrigation
Century Link	Coaxial, Fiber Optic
Cox Communication	CATV, Fiber Optic
Southwest Gas	Gas
Media Com	CATV
Arizona Water Company	Water
Central Arizona Canal (CAP)	Irrigation
AT&T	Fiber Optic
City of Mesa Utilities	Gas, Water

The utility stakeholders identified by Blue Stake were contacted to determine what facilities are within in the project study area and to request mapping. The following provides descriptions of the existing utilities within the Meridian Road corridor by utility stakeholder.

*Overhead Electric:* SRP overhead electric lines exist for the majority of the alignment of Meridian Road along the east side of the right-of-way. In addition, there are 500kV overhead electric transmission lines crossing Meridian Road diagonally just south of the Powerline Floodway and between Elliot Road and Guadalupe Road. 69kV overhead electricity lines cross Meridian Road at Southern Avenue, University Drive/Superstition Boulevard and just north of Brown Road/Lost Dutchman Boulevard. Finally, a pair of 230 KV lines paralleling the 69kV line also crosses Meridian Road just north of Brown Road.

*Underground Electric:* SRP underground electric lines exist in the vicinity of the new subdivisions along Meridian Road from half mile north of Elliot Road to one mile south of Elliot Road.

*Irrigation:* The CAP canal crosses Meridian Road at the US 60 overpass.

*Natural Gas:* The City of Mesa operates natural gas facilities in the corridor including a 4-inch pipeline extending in Meridian Road from Germann Road south to Queen Creek Road.

*Potable Water:* Arizona Water Company has numerous facilities in Meridian Road from Southern Avenue north to McDowell Boulevard. The City of Mesa operates a potable water system along Meridian Road. These facilities consist of a pipeline ranging from 12 inches to 20 inches in diameter extending from half mile north of Elliot Road to Warner Road and a pipeline ranging from 12 inches to 16 inches extending from Pecos Road to Germann Road. In addition, there are two City of Mesa well sites along Meridian Road located at the northwest corner of Germann Road and Meridian Road and at half mile south of Pecos Road on the west side of Meridian Road.

*Sanitary Sewer:* North of US 60 there are sanitary sewers located both under Meridian Road and crossing at major intersections within the study area.



*Telephone:* Both CenutryLink and Cox Communication have facilities along Meridian Road between Ocotillo Road and Lenora Road and from Rittenhouse Road to Empire Boulevard.

*Cable TV:* Cox Cable has facilities along Meridian Road in the vicinity of the new subdivisions on the west side of Meridian Road between half mile north of Elliot Road and one mile south of Elliot Road. Media Com has facilities along Meridian Road north of US 60.

### **Recreation Trails, Parks/Areas, and Open Space**

There is one National Forest and one regional park located within the study area: the Tonto National Forest located at the northern terminus of Meridian Road and Uesry Mountain Regional Park located northwest of the intersection of McKellips Boulevard and Meridian Road, adjacent to the Tonto National Forest. There are several access points to trails associated with these two regional parks along Meridian Road north of McKellips Boulevard. There is an existing Mesa Community Park, Skyline Park, located at Broadway Road and Crismon Road, approximately two miles west of Meridian Road. An existing Mesa Neighborhood Park, Augusta Ranch Park, is located at Guadalupe Road and Ellsworth Road, approximately three miles west of Meridian Road. An existing Apache Junction Community Park, Prospector Park, is located on Bureau of Land Management land north of Lost Dutchman Boulevard on Idaho Road, approximately two miles east of Meridian Road within the City of Apache Junction. Several lineal parks are located between Apache Trail and Southern Avenue and Idaho Road and Meridian Road. These lineal parks are oriented towards hiking, biking, horseback riding and walking trails.

### **Existing Access Management Conditions and Policy/Guidelines**

Access management is a set of techniques that can be used to control access to highways, major arterials and other roads. The benefits of access management include improved traffic movement, reduced accidents, and fewer vehicle conflicts. Successful access management managed by change in access density seeks to simultaneously enhance safety, preserve capacity and provide for pedestrian and bicycles needs.

The corridor is split into two unique areas. Between Southern Avenue and Brown Road/Lost Dutchman Boulevard is an urban environment where as south of Southern Avenue is more rural. North of Southern Avenue stop signs control traffic turning into Meridian Road at most access points. The exceptions are Broadway Avenue, Apache Trail and University Drive/Superstition Boulevard where traffic signals control access on to and from Meridian Road. South of Southern Avenue the rural nature of the study corridor combined with low traffic volumes and the lack of paved roadways means that most of the roadway does not have access control. Access to the few paved sections of Meridian Road further south of Southern Avenue is by partial stop access control.

Access control procedures and design vary within the study corridor depending on the controlling jurisdictions although only minimally. Pinal County Comprehensive Plan references the access management policies set out in the Regional Significant Routes Plan for Safety and Mobility. Within the Cities of Mesa and Apache Junction there are no specific access control



guidelines; however, access control is governed by their respective Design Standards. **Table 4** summarizes the access control within the study corridor. With Meridian Road following the section line between the various jurisdictions, approval for revisions to existing access or the establishment of new access points will need to be governed through some form of mutual agreement.

**Table 4: Access Control Guidelines per Jurisdiction (for Urban Arterial Roads)**

Access Control Feature	Pinal County	City of Mesa	City of Apache Junction
Medians	Divided with full or directional median openings at ¼ mile spacing	Divided with full or directional median openings at ¼ mile spacing	Divided with full or directional median openings at ¼ mile spacing
Traffic Signal Spacing	¼ mile and ½ mile locations fully coordinated and progressed where warranted	Between ¼ and ½ mile and between ½ and ¾ mile locations fully coordinated and progressed where warranted	¼ mile and ½ mile locations fully coordinated and progressed where warranted
Typical Traffic Control	Signalized, two-way stop	Signalized, two-way stop	Signalized, two-way stop
Access Driveway	100 feet from intersection	100 feet from intersection	100 feet from intersection
Full Access Driveway from Signal	660 feet	880 feet	880 feet
Partial; Access Driveway from Signal	330 feet	660 feet	660 feet
Driveway spacing	165 feet to 330 feet	60 feet (min)	N/A
Grade Separated Interchange Spacing	One mile location where warranted	One mile location where warranted	N/A
Grade Separated Interchange Type	May include SPUI or tight diamond if warranted and feasible	May include SPUI or tight diamond if warranted and feasible	N/A
Frontage Road	Possible	Possible	N/A
On-Street Parking	Prohibited	Prohibited	N/A

Within the more rural areas, access control will be established by identifying the supporting street system necessary to sustain existing and planned development in the corridor. The anticipated street system that will serve as the backbone for development in the study corridor will generally be the arterial street grid system. These roadways are expected to be developed as urban arterials as the population of the region grows. Existing developed arterials located within the more rural areas that intersect Meridian Road include Southern Avenue, Baseline Road, and Elliot Road. The remaining section lines that will serve as the corridors for future arterials are undeveloped. Other existing and future facilities in the corridor listed within the section of this report titled **Roadway Network Deficiencies** will also have a profound effect on future access control.

**Existing Network and Roadway Classifications**

A field review was conducted to inventory the existing number of lanes, posted speed limits, intersection lane configurations and traffic control type. The resulting information is depicted in **Figure 7**, **Figure 8** and **Figure 9** respectively.

Functional classification is the grouping of streets and highways into classes according to the character of service in which they are intended to provide. **Figure 10** depicts the current FHWA approved functional classification for roadways within the study area.

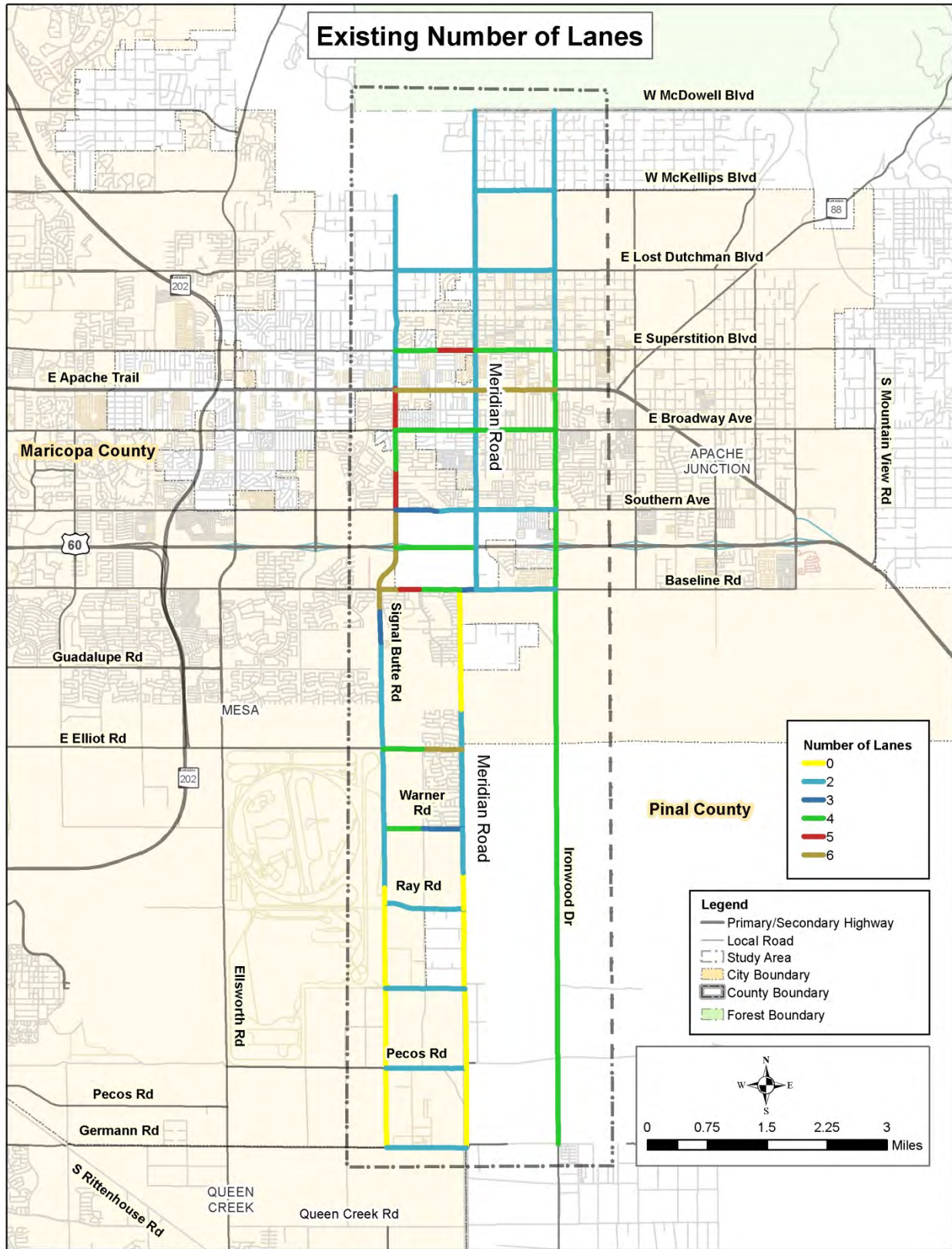

Figure 7: Existing Number of Lanes



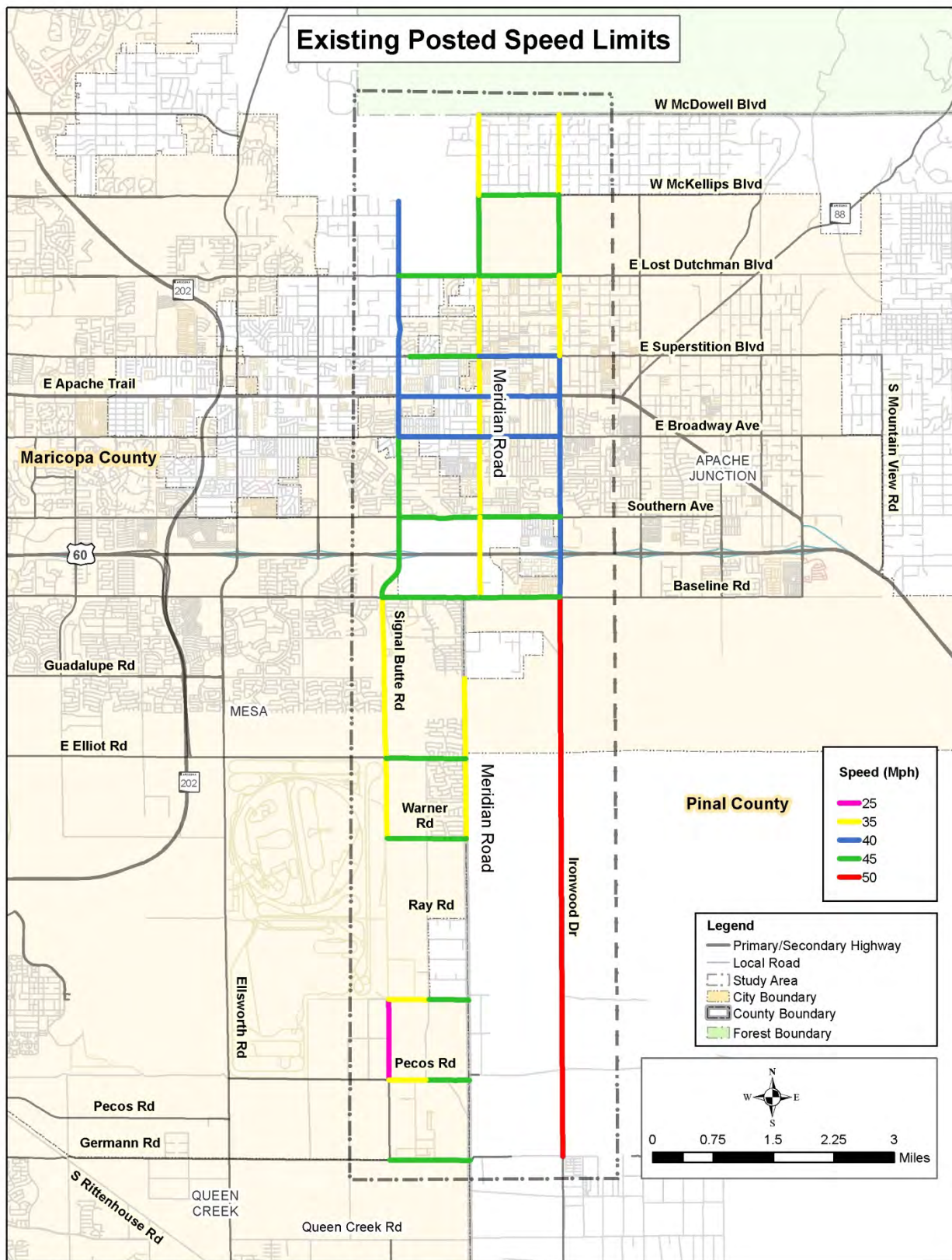

Figure 8: Posted Speed Limits

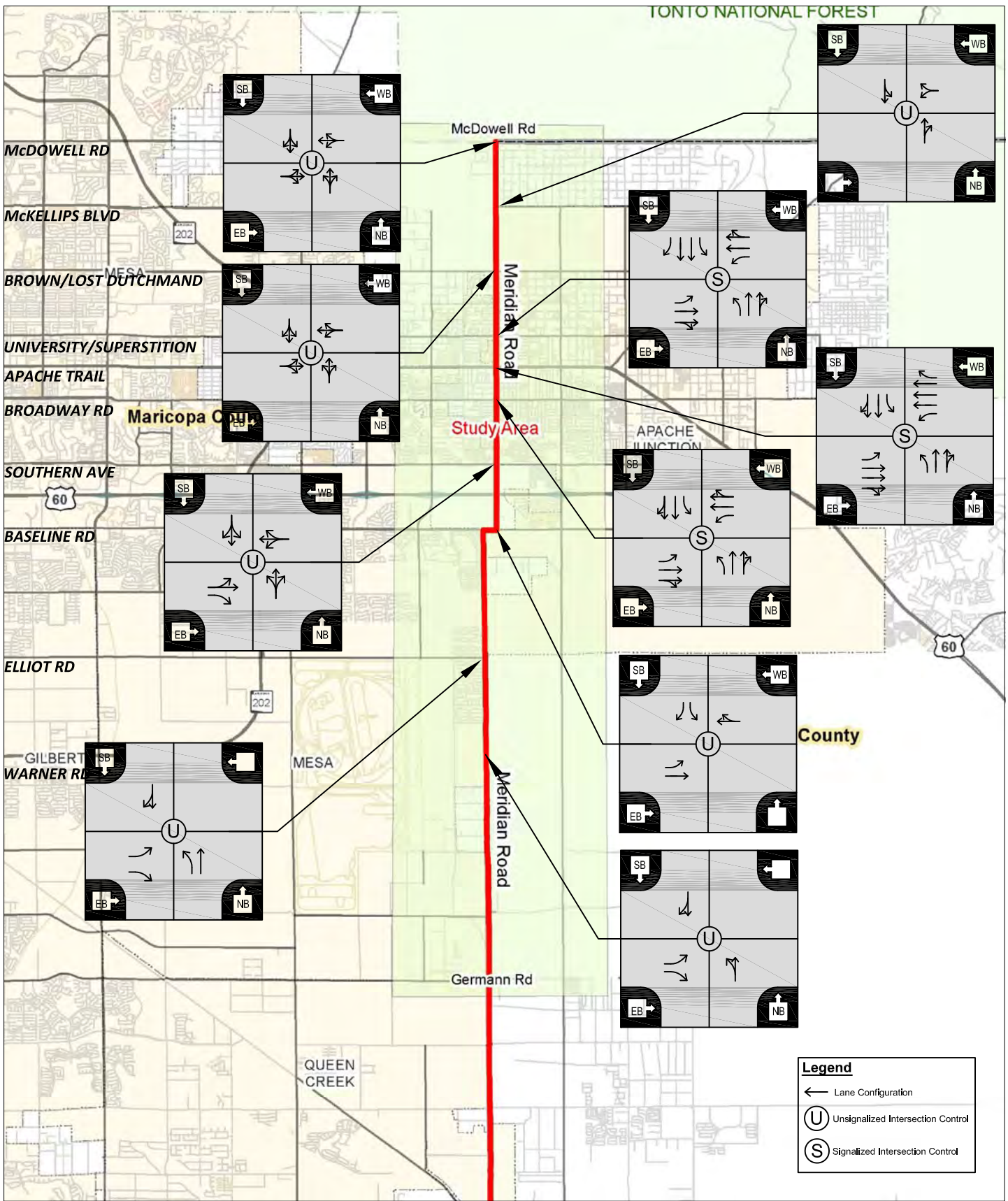

Figure 9  
Existing 2012 Lane Configuration



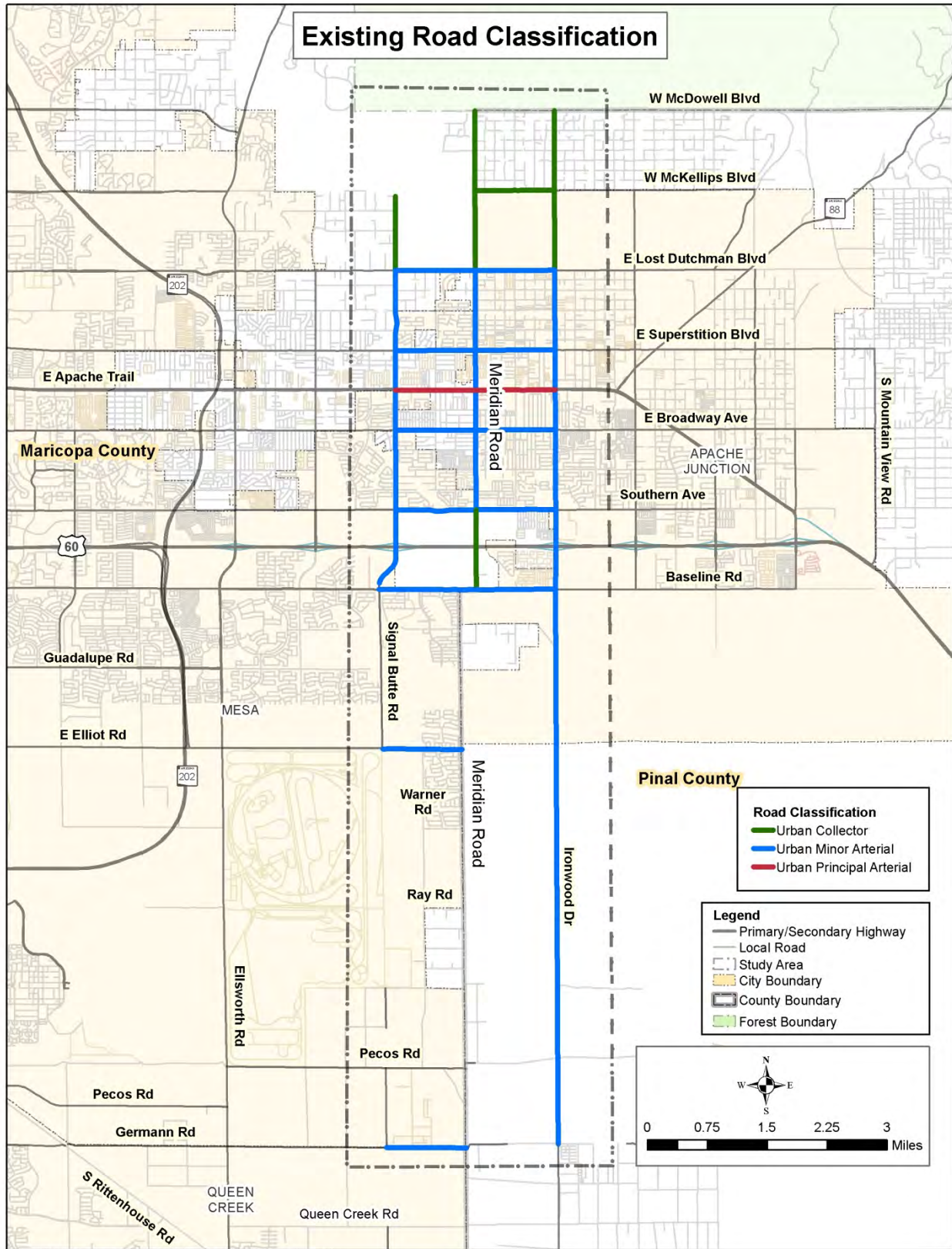

Figure 10: Existing FHWA Functional Classification

Existing right-of-way along Meridian Road varies between 33’ feet and 75’ feet with the majority of the existing right-of-way north of Baseline Road at 55 feet and the majority of the existing right-of-way south of Baseline Road at 65 feet. **Table 5** provides the existing right-of-way along Meridian Road.

**Table 5: Existing Right-of-Way Widths**

Roadway	From	To	ROW Width		Pavement Width
			West of Centerline (MCDOT)	East of Centerline (PCDOT)	
Meridian Road	McDowell Road	McKellips Boulevard	●40' North of Canyon St ●55' South of Canyon St	N/A	●24'
	McKellips Boulevard	Lost Dutchman Road	●55' from 1/2 mile south of McKellips Blvd to Lost Dutchman	N/A	●24'
	Lost Dutchman Road	Superstition Boulevard	●55' North of Windsong St ●33' South of Windsong St ●55' South of Smoke Tree St ●65' South of Silverado Estates	●50' for a 285' segment south of Lost Dutchman ●50' between Windsong St and Concho Street ●50' between Tepee St and 160' south of Shiprock St ●33' between 160' south of Shiprock St and Roundup St ●33' between Mockingbird St and Silverado Estates ●50' between Silverado Estates and Superstition Boulevard	●24' ●40' ●45' ●45' ●45' ●76'
	Superstition Boulevard	Apache Trail	●55'	●50' for a 95' segment south of Superstition Boulevard ●50' from Gregory St to Apache Trail	●62' ●24' ●62' at intersection
	Apache Trail	Broadway Avenue	●33' for a 200' segment south of Apache ●55' from 200' south of Apache Trail to 6th Ave ●40' between 6th Ave and Southern	●40'	●65' ●26' ●65' at intersection
	Broadway Avenue	Southern Avenue	●65' North of Wier Ave ●55' South of Wier Ave ●65' for 143' near Flower Cir	●50' from 290' south of Broadway Ave to Southern Ave	●26' ●widens at intersection
	Southern Avenue	Baseline Road	●55'	●50'	●26'
	Baseline Road	Guadalupe Road	●65'	N/A	No Pavement
	Guadalupe Road	Elliot Road	●55' for 1/2 mile south of Guadalupe ●65' for 1/2 mile north of Elliot	N/A	No Pavement
	Elliot Road	Warner Road	●65' north of Mesquite St ●55' south of Mesquite St ●65' from 200' north of Renfield Ave ●70' from 600' north of Warner Road	N/A	●36'
	Warner Road	Ray Road	●55' to north of Starkey Ave ●65' South of Starke Ave to 545' north of Ray Rd ●75' from 545' north of Ray Rd to Ray Road	N/A	●32' ●No Pavement ●No Pavement
	Ray Road	Williams Field Road	●65'	N/A	No Pavement
	Williams Field Road	Pecos Road	●55'	N/A	No Pavement
	Pecos Road	Germann Road	●65' from Pecos Road to 565' north of Germann Road ●75' for a 565' segment north of Germann Road	N/A	No Pavement

**Existing Pavement Evaluation**

Maricopa County Department of Transportation (MCDOT) operates a Pavement Management Program which provides a systematic process to plan pavement preservation activities. The program provides, analyzes and summarizes roadway and pavement information in order to

identify optimum strategies and select cost-effective pavement preservation methods. MCDOT Operations uses three categories to evaluate the roadway. The first category is the pavement condition rating (PCR) which rates the condition of the pavement by measuring the physical distresses in the pavement such as cracking and potholes. The next rating category is the international roughness index (IRI), which measure the roughness of the pavement surface. The final rating is the Sufficiency Rating. This rating is based on six different types of geometric distress which are inventoried for safety. These distresses are: lane width, shoulder width, bottlenecks, drainage, and horizontal and vertical sight distance. **Table 6** provides the current pavement condition survey for the roadways within the study area. **Table 7** provides a description for the pavement condition ratings.

**Table 6: Current Pavement Condition Survey**

From Road	To Road	PCR	IRI	Suff	Last Work Done	Date
Warner Road	Renfield Avenue	88	88	89	Open,Grade,Drain,Base & Pvmt	5/20/2009
Renfield Avenue	Mesquite Street	88	88	89	Open,Grade,Drain,Base & Pvmt	5/20/2009
Baseline Road	Southern Avenue	40	225	91	Crack-fill	11/12/2010
Southern Avenue	Pueblo Avenue	40	361	86	Crack-fill	11/16/2010
Pueblo Avenue	Broadway Road	40	361	86	Crack-fill	11/15/2010
Broadway Road	Apache Trail	54	325	83	Crack-fill	11/16/2010
Apache Trail	Apache Trail	60	325	91	Crack-fill	11/17/2010
Apache Trail	University Drive	73	218	97	Crack-fill	11/18/2010
University Drive	Brown Road	58	218	89	Crack-fill	11/18/2010
Brown Road	McKellips Boulevard	60	225	89	Crack-fill	11/17/2010
McKellips Boulevard	McDowell Road	85	149	97	Crack-fill	11/17/2010

**Table 7: Pavement Condition Rating**

Rating	Description
Less than 40	Poor
40-54	Fair
55-70	Good
71-84	Very Good
85-100	Excellent

The average PCR for county roads in Maricopa County is 82.61. The average PCR for Meridian Road from Warner Road to McDowell Boulevard is a good rating at 62.00. **Table 8** provides a description for the international roughness Index.

**Table 8: International Roughness Index**

Rating	Description
0-59	Very Smooth
60-94	Smooth
95-170	Average
171-220	Rough
Greater than 220	Very Rough



The average roughness of the county roads in Maricopa County is 163.09, which is rated as average. The average IRI rating for Meridian Road between Warner Road and McDowell Boulevard is 235, which is rated as very rough.

A sufficiency rating number between 0 and 100 is determined for each section of road with 100 being the best. If the rating is less than 35, the roadway is programmed for re-construction. The average sufficiency rating for Meridian Road between Warner Road to McDowell Boulevard is 90.

### Existing Multimodal Transportation

City of Apache Junction has limited transit providers in the area. Two private-sector operators currently provide demand-response public transportation service in the area. These providers offer service to either Phoenix Sky Harbor or Phoenix Mesa Gateway Airport, as well as local service to Wal-Mart, Superstition Springs Mall, and a variety of medical appointments. The remaining transit providers within the City of Apache Junction are operated by East Valley Senior Services provided mileage reimbursement programs, coupon booklets for cab fare, and passenger van service for medical appointments and grocery shopping. There are currently bike lanes along Meridian Road between University Drive/Superstition Boulevard and Tepee Street (half mile north of University Drive/Superstition Boulevard). There is an existing sidewalk along the west side of Meridian Road between Tepee Street and University Drive/Superstition Boulevard, between a half mile north of Elliot Road and Warner Road, and for an approximately half mile segment south of Warner Road. A discontinuous sidewalk exists along Meridian Road between University Drive/Superstition Boulevard and Southern Avenue.

## V. Existing Socioeconomic Data

### Jurisdictions within the Corridor

The study area is segmented into five separate jurisdictions (City of Apache Junction, City of Mesa, Town of Queen Creek, Pinal County and Maricopa County) that control development through their own adopted general/comprehensive plans, zoning ordinances, and subdivision regulations.

### Existing Land Use

From McDowell Boulevard to Southern Avenue the primary land use is low to medium density residential with pockets of commercial. The residential is characterized by a number of RV parks such as El Dorado Mobile Home Resort and Coral Sand RV Park. Southern Avenue to Baseline Road land use patterns include primarily rural-residential with small parcels of commercial, industrial and low density residential. A small pocket of fabrication and heavy equipment manufacturing uses is located among other commercial and industrial operations south of Baseline Road. Further south the existing land use pattern within the study area primarily reflects the rural residential and agricultural themes that have existed in the region for decades. The eastern half of the study area is occupied largely by agricultural uses and large-lot, single-family homes such as Sunland Springs Subdivision, Bella Via and Superstition View Ranchettes.



Currently undeveloped rural land platted for future development is located to the west of Meridian Road. The residential developments located to the north typically exhibit smaller lot sizes (approximately six units to the acre) than those located to the south.

Several industrial employment areas are located in south Mesa and east Queen Creek. Specifically, the Landstar Polymer plant, located at the northwest corner of the intersection of Meridian and Pecos roads, is a rubber recycling facility currently under development that is expected to be a cornerstone of the Meridian Business Park in Mesa. Similar uses nearby include TRW Safety Systems, which manufactures automobile airbags, and the Arch Chemical semiconductor chemical manufacturing plant. **Figure 11** shows the existing land uses within the study corridor.

### Existing Zoning

The existing zoning districts utilized by the City of Mesa, City of Apache Junction, Maricopa County and Pinal County that fall within the study area have been collapsed into five general categories to illustrate a consistent pattern of zoning among differing county and city/town designations. The majority of the planning area is primarily occupied by single-family residential, agricultural, and farming-related uses.

The majority of the northern portion of the study area from Southern Avenue to University Drive/Superstition Boulevard, is zoned for medium density single-family homes. In addition there are several isolated areas of community commercial mainly at the corners of the major arterial intersections. North of University Drive/Superstition Boulevard, the zoning changes to low density residential with large areas of park and open space notably Utery Mountain Regional Park and the Tonto National Forest. Between Southern Avenue and Baseline Road, the zoning is categorized as light industry/ Business Park.

South of Baseline Road most of the corridor has been designated as low to medium density single-family residential. Small islands of light industrial zoning exist just north of Guadalupe Road on the east side of Meridian Road and again on the west side around Pecos Road and Germann Road.

### Land Jurisdiction and Ownership

The study area contains property within portions of unincorporated Pinal and Maricopa Counties as well as substantial land areas currently incorporated into the communities of Mesa, and Apache Junction. The City of Mesa's land occupies a majority of the western portion of the corridor. To the east, the land is occupied by the City of Apache Junction north of Elliot Road and by Unincorporated Pinal County to the south. Private entities own a majority of the land within the study area. The only exception to this trend exists on the west side of the study area bordered by Baseline Road to the south and Southern Avenue to the north. At this location, Arizona State Trust land and the Bureau of Reclamation, which operates the CAP canal, are the property owners. On the east side of the study area, in Pinal County from Baseline Road to Germann Road, nearly all of the study area is held as Arizona State Trust land in both unincorporated Pinal County and the City of Apache Junction. In addition, the Bureau of

Reclamation also owns a small portion of this region located to the north of Guadalupe Road that is occupied partially by industrial and manufacturing uses. **Figure 12** shows the land ownership within the study area.

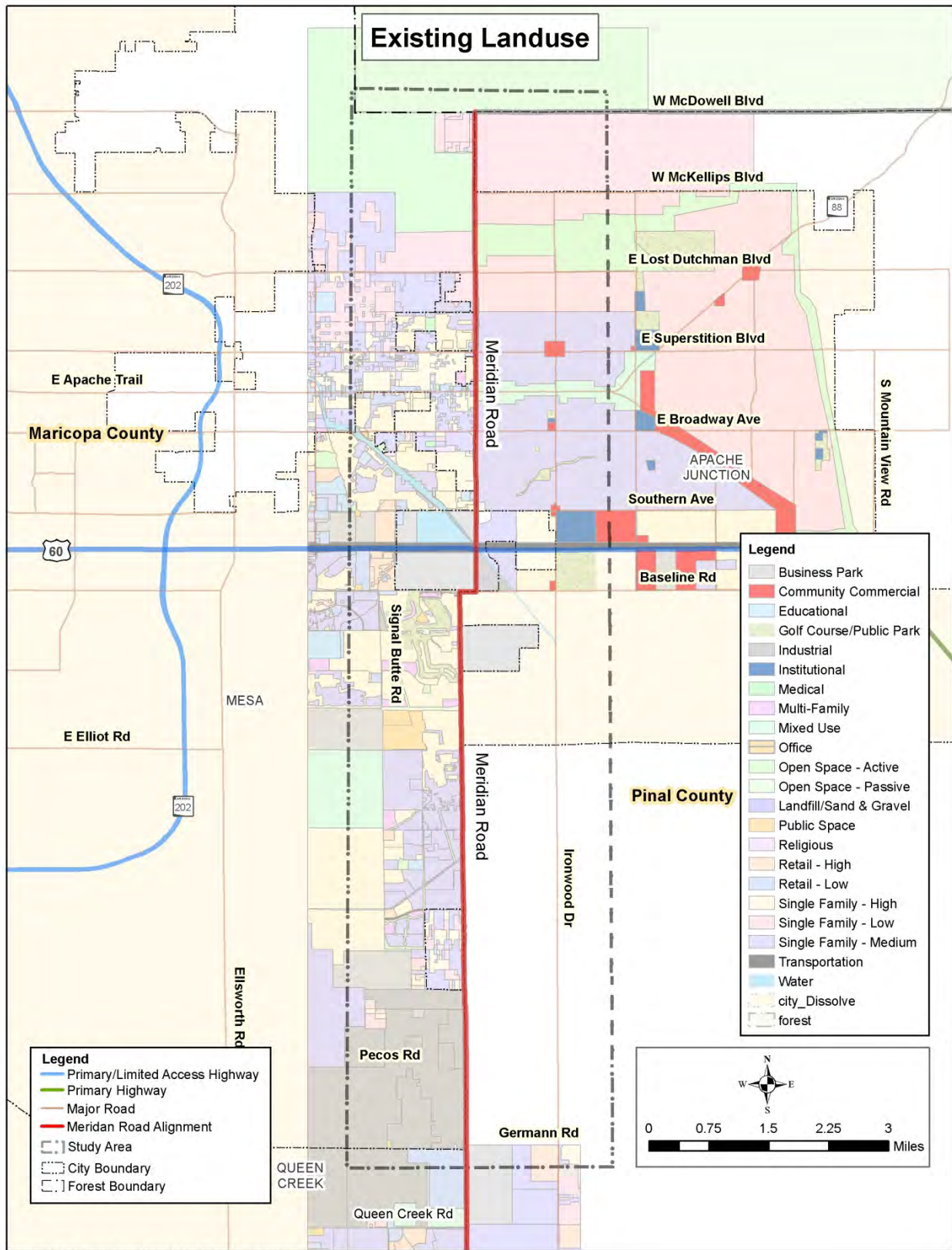

Figure 11: Existing Land Uses



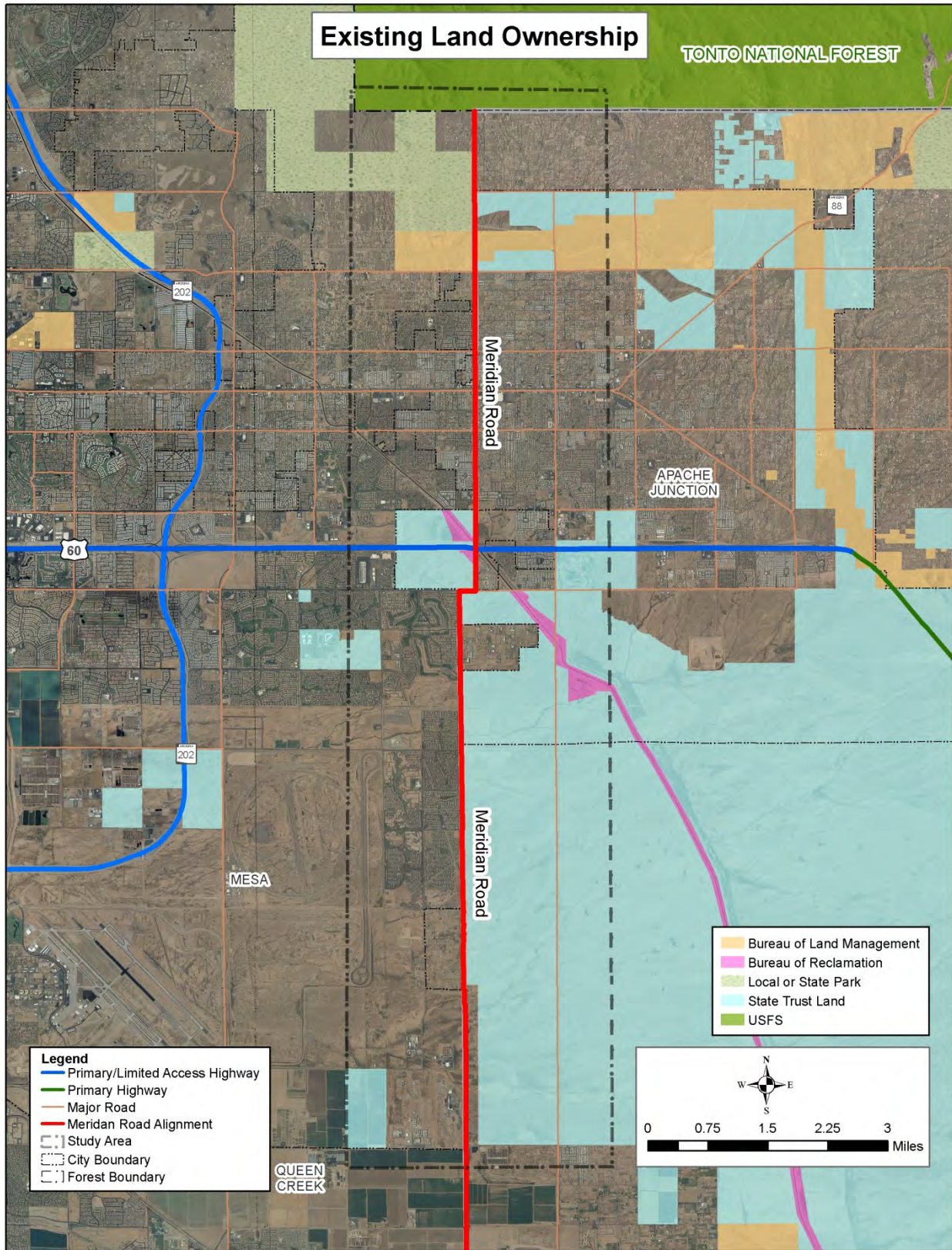

Figure 12: Existing Land Ownership



## VI. Existing Traffic Data

### Existing 2012 Traffic Volumes

Traffic Research and Analysis (TRA) collected forty-eight-hour approach and departure volumes with automatic traffic recorders in fifteen minute intervals at nine locations within the study area along Meridian Road to obtain the ADT volumes. A seasonal adjustment factor of 20% was applied to the approach and departure volumes. The seasonal adjustment factor was determined based upon ADOT's monthly ADT volumes collected within the study area. The 2012 adjusted ADT volumes are shown in **Table 9** and illustrated in **Figure 13**. A detailed report of the traffic counts are contained in Appendix A.

TRA counted current traffic volumes at ten existing intersections within the study area on Tuesday, May 22, 2012. Turning movement counts were collected in fifteen minute intervals from 6:00 AM to 9:00 AM and from 3:30 PM to 6:30 PM.

Based on information from the ADOT Transportation Data Management System, in the Apache Junction area the month in which the traffic volumes peak is 20 percent higher than traffic volumes in the month of May. Therefore, a seasonal adjustment factor of 20% was applied to the turning movement volumes. The 2012 adjusted turning movement counts for the AM and PM peak periods are shown in **Figure 14**. A detailed report of the turning movement counts are contained in Appendix A.

Table 9: 2012 Average Daily Traffic Volumes

Meridian Road Segment	Direction	Average Daily Traffic (VPD) 2012*
McDowell Road to McKellips Boulevard	NB	612
	SB	655
McKellips Boulevard to Brown Road/Lost Dutchman Boulevard	NB	1,534
	SB	1,632
Brown Road/Lost Dutchman Boulevard to University Drive/Superstition Boulevard	NB	2,707
	SB	2,914
University Drive/Superstitions Boulevard to Apache Trail	NB	3,494
	SB	3,352
Apache Trail to Broadway Road	NB	3,350
	SB	3,673
Broadway Road to Southern Avenue	NB	2,633
	SB	2,467
Southern Avenue to US 60	NB	2,633
	SB	2,467
US 60 to Baseline Road	NB	1,570
	SB	1,495
Guadalupe Road to Elliot Road	NB	731
	SB	697
Elliot Road to Warner Road	NB	781
	SB	713

\* Approach and Departure volumes are adjusted to account for a 20% seasonal factor

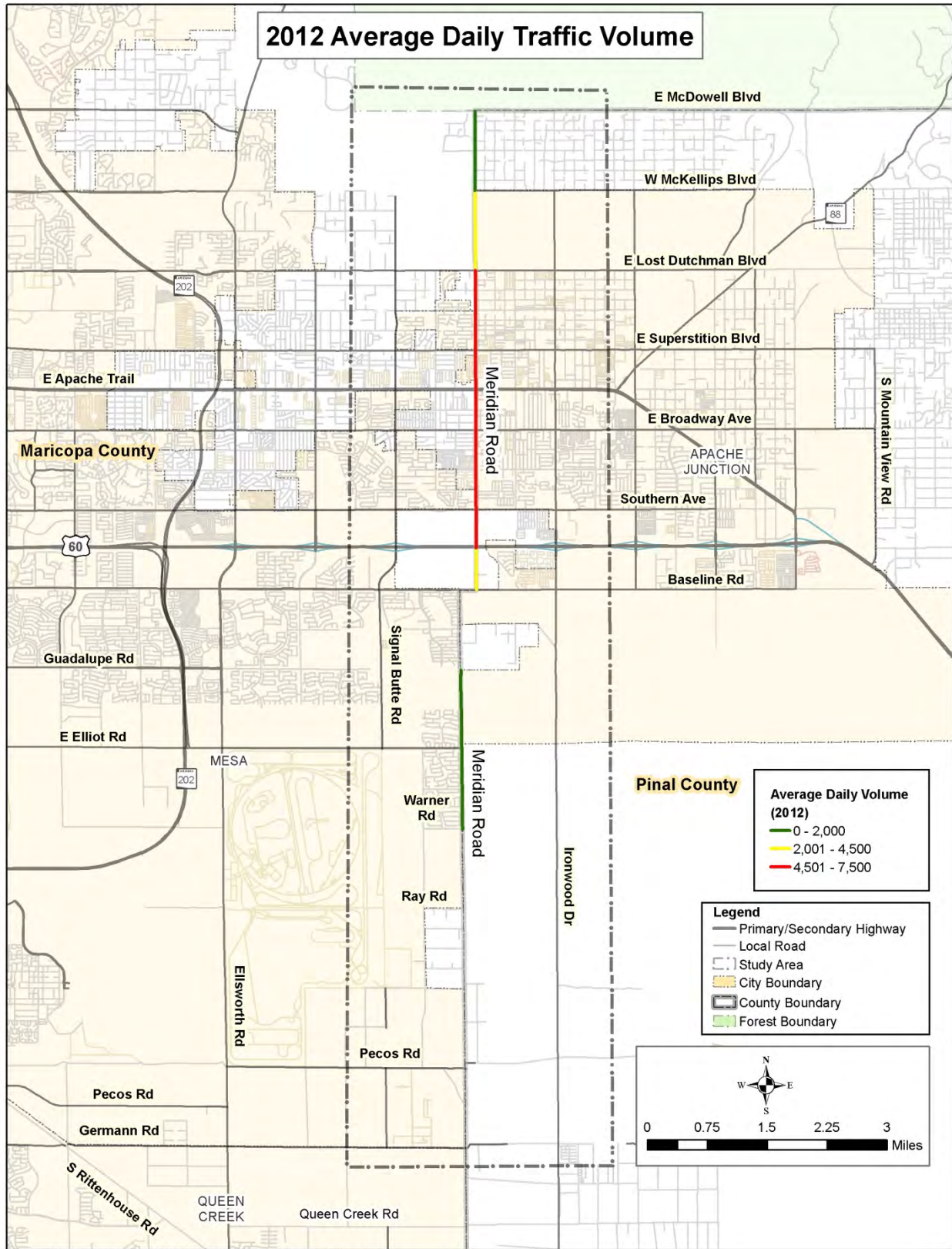

Figure 13: Existing 2012 Average Daily Traffic Volumes

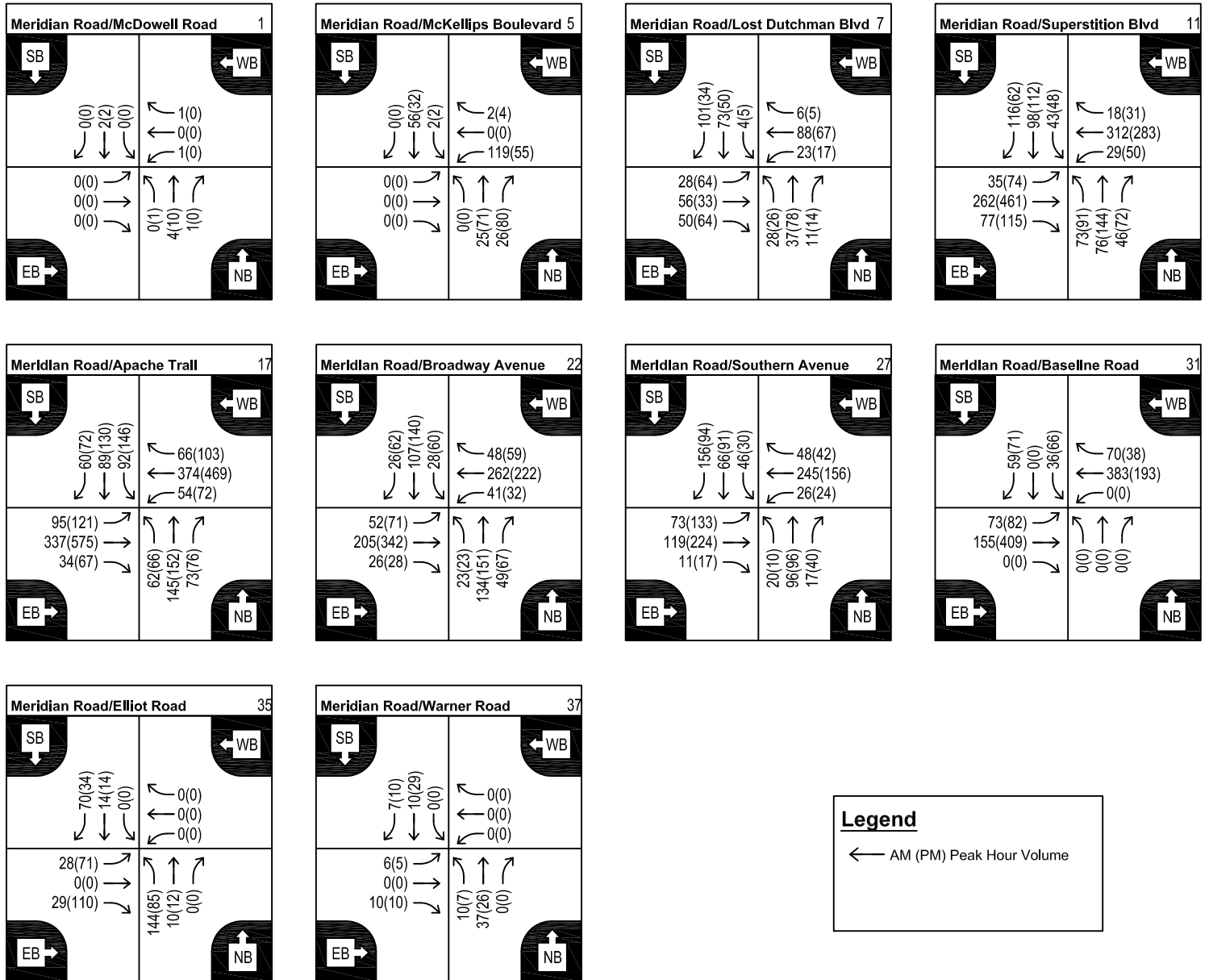

Figure 14  
Existing 2012 Turning Movement Volumes



### Existing 2012 Level of service

The ability of a transportation system to transmit the transportation demand is characterized as its level of service (LOS). LOS is a rating system from “A”, representing the best operation, to “F”, representing the worst operation. The appropriate reference for LOS operation is the *Highway Capacity Manual*, published by the Transportation Research Board. This manual characterizes the LOS for an urban street facility as described in **Table 10**.

**Table 10: Level of Service Criteria for Urban Street Facilities**

Level-of-Service	Characterized by HCM as:
A	Primarily free-flow speed. Vehicles are completely unimpeded in their ability to maneuver within the traffic stream. Control delay at the boundary intersections is minimal. The travel speed exceeds 85% of the base free-flow speed.
B	Reasonably unimpeded operation. The ability to maneuver within the traffic stream is only slightly restricted and control delay at the boundary intersections is not significant. The travel speed is between 67% and 85% of the base free-flow speed.
C	Stable operation. The ability to maneuver and change lanes at mid-segment locations may be more restricted than at LOS B. Longer queues at the boundary intersections may contribute to lower travel speeds. The travel speed is between 50% and 67% of the base free-flow speed.
D	Less stable condition in which small increases in flow may cause substantial increases in delay and decrease in travel speed. This operation may be due to adverse signal progression, high volume, or inappropriate signal timing at the boundary intersections. The travel speed is between 40% and 50% of the base free-flow speed.
E	Unstable operation and significant delay. Such operation may be due to some combination of adverse progression, high volume, and inappropriate signal timing at the boundary intersections. The travel speed is between 30% and 40% of the base free-flow speed.
F	Flow at extremely low speed. Congestion is likely occurring at the boundary intersections, as indicated by high delay and extensive queuing. The travel speed is 30% or less of the base free-flow speed. Also, LOS F is assigned to the subject direction of travel if the through movement at one or more boundary intersections has a volume -to-capacity ratio greater than 1.0.

In general, LOS A and B represent no congestion, LOS C and D represent moderate congestion, and LOS E and F represent severe congestion.

LOS can be calculated for roadway segments, intersections, and freeway mainline lanes and ramps. LOS estimates also can be calculated for different periods, including daily conditions and peak hour conditions. The LOS analysis discussed in this section focuses on planning level roadway segment performance within the study area based on daily roadway segment volumes. Analysis of study area intersections based on peak hour turning movement volumes and anticipated delay is discussed in the following section.

The widely accepted *2009 Quality/Level of Service Handbook* published by the Florida Department of Transportation was the planning guidelines relating LOS to daily volumes to

estimate capacity for roadway segments. These guidelines are not an exact description of the actual operating LOS on a particular roadway segment, but they give an indication of when the roadway falls below acceptable levels of service.

**Table 11** shows the capacity threshold values for the ADT levels obtained in May of 2012 for this study. Arterial street capacity thresholds were derived directly from “Table 4-1, Generalized Annual Average Daily Volumes for Florida’s Urbanized Areas (Freeway & State Two-Way Arterial Facilities),” published by the Florida Department of Transportation (FDOT) in the widely accepted 2009 Quality/Level of Service Handbook. Information relevant to arterial facilities in FDOT’s 2009 Quality/Level of Service Handbook served as reference for the development of specific values to reflect current Metropolitan Phoenix area conditions and future conditions anticipated to exist ultimately in the Study Area. Pertinent data related to the 2009 Quality/Level of Service Handbook is included in Appendix B.

As indicated in **Table 11**, LOS D was considered the threshold of acceptable operations for arterial facilities. The LOS threshold measures reflect the traffic volume characteristics of each facility or grouping of facility types. The selection of these LOS threshold values accounts for the expectations of the drivers as well as the relative costs associated with the construction of each facility type. ADT volumes in excess of the thresholds illustrated in **Table 11** indicate a condition in which the volumes on a given roadway segment exceeds the planning-level capacity for that facility.

**Table 11: Summary of Generalized Annual Average Daily Volume Threshold Values by Facility Type**

Facility Type	Number of Through Lanes	Roadway Classification	Level of Service Threshold	Daily Volume Threshold Values
Major Arterial	6	Class I (<2 Signals/Mi.)	LOS D	55,300
Minor Arterial	5	Class I (<2 Signals/Mi.)	LOS D	46,000
Minor Arterial	4	Class I (<2 Signals/Mi.)	LOS D	36,700
Minor Arterial	2	Class I (<2 Signals/Mi.)	LOS D	16,500

**Figure 15** depicts the current LOS for segments of Meridian Road within the study area.

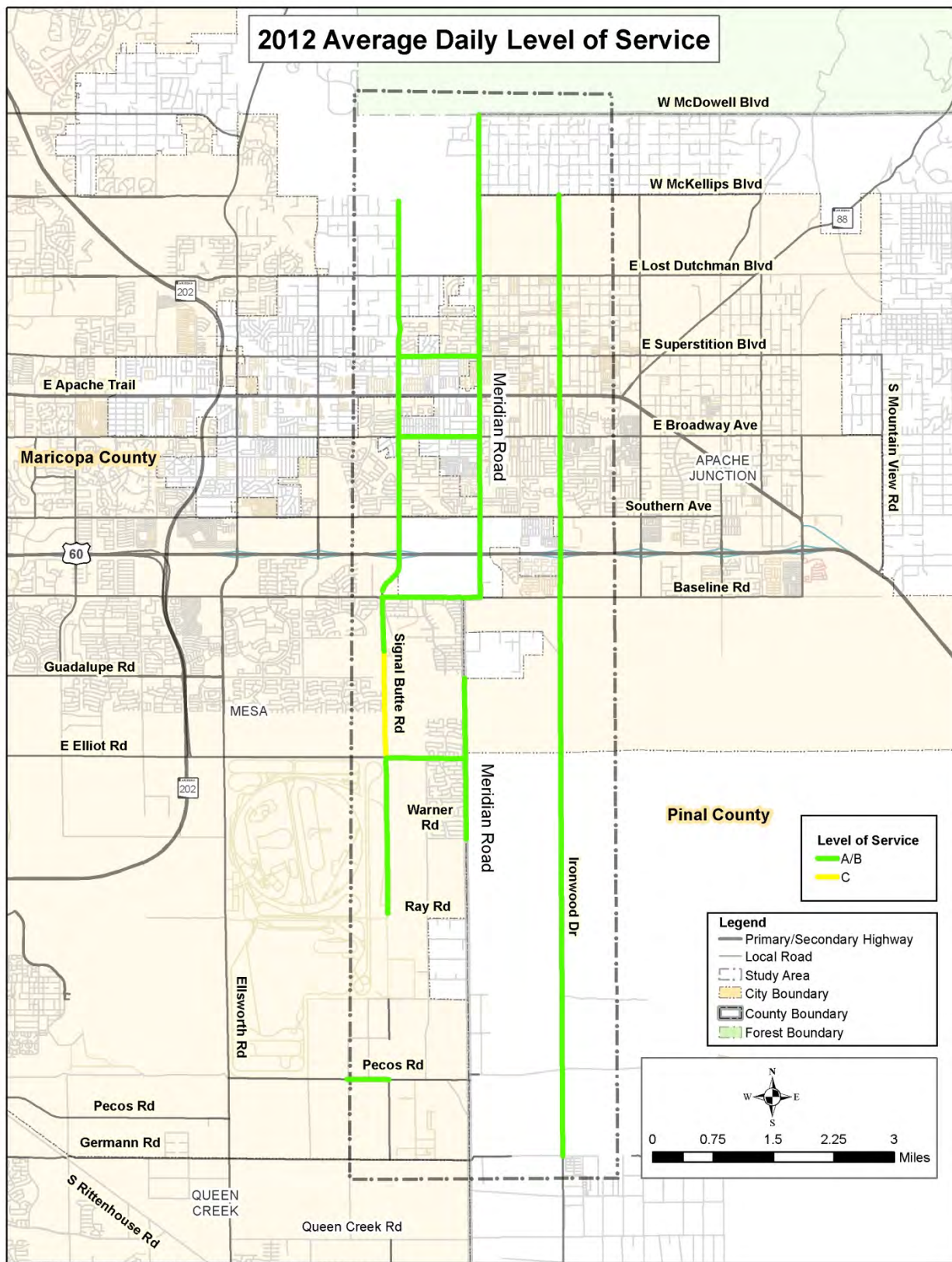

Figure 15: 2012 Average Daily Level of Service

The HCM considers the average delay per vehicle as the measure to determine the LOS of a signalized intersection. The delay and LOS are calculated for the intersection, each approach, and each turning movement. **Table 12** lists the LOS criteria for signalized intersections as stated in the *Highway Capacity Manual*. **Table 13** the level-of-service criteria for the unsignalized study area intersections.

**Table 12: Level-of-Service Criteria for Signalized Intersections**

Level-of-Service	Average Control Delay (s/veh)
A	≤ 10
B	> 10-20
C	> 20-35
D	> 35-55
E	> 55-80
F	> 80

**Table 13: Level-of-Service Criteria for Unsignalized Intersections**

Level-of-Service	Average Control Delay (s/veh)
A	≤ 10
B	> 10-15
C	> 15-25
D	> 25-35
E	> 35-50
F	> 50

One of the important conditions for determining LOS at an intersection is the number of lanes provided for each movement on each approach at the intersection. The existing intersection geometry for each study intersection is discussed within the section of this report titled **Existing Roadway Network**. The existing intersection geometry for the study area intersections is shown in **Figure 9**.

The LOS for the study area intersections was evaluated using *Synchro* software, which utilizes the criteria described in **Table 12** and **Table 13**. The existing LOS for the signalized and unsignalized intersections within the study area are shown in **Figure 16**. **Appendix C** provides the complete results of the existing 2012 LOS analyses.



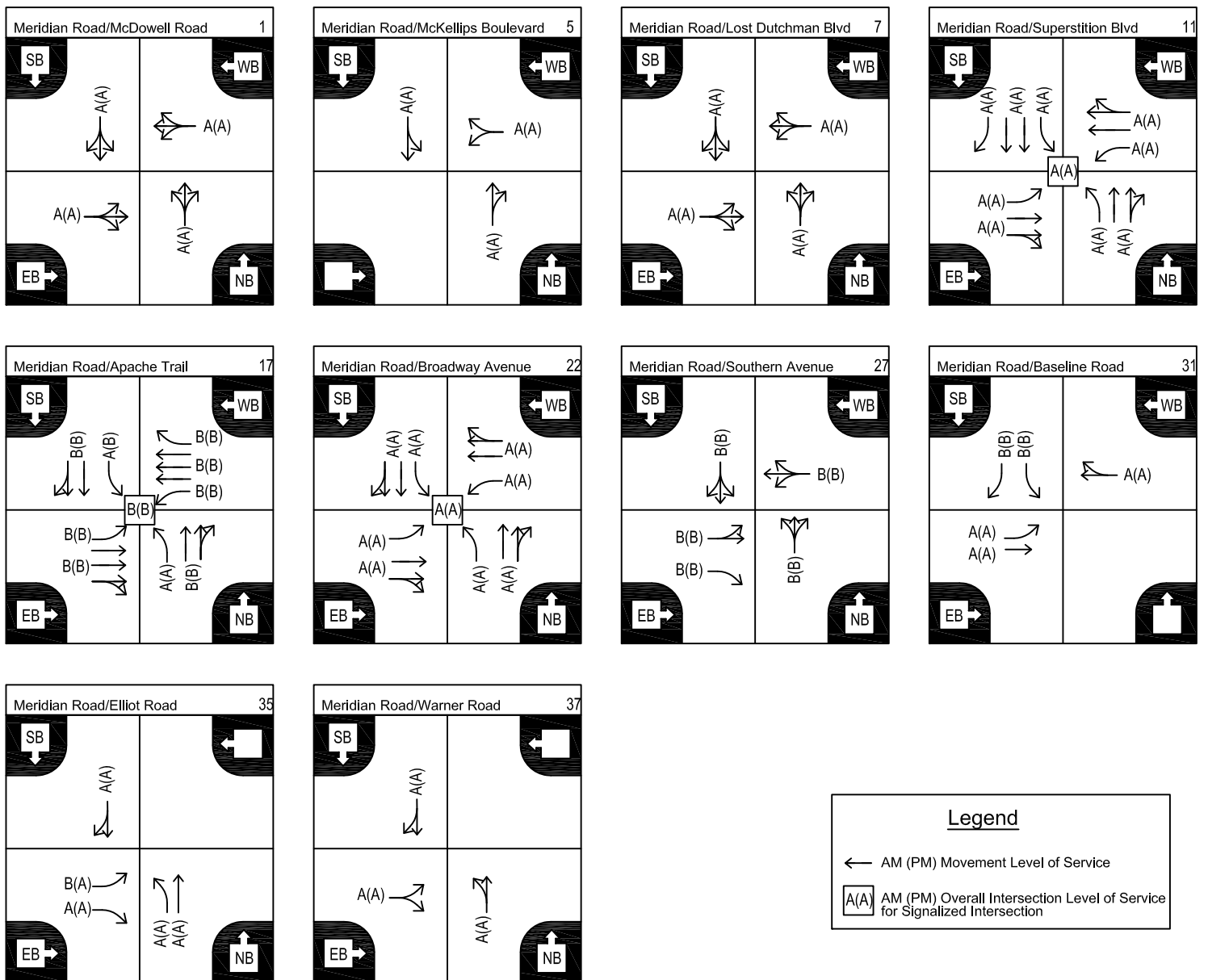

Figure 16  
Existing 2012 Level of Service

## Crash Data

Crash analysis was conducted for Meridian Road within the study area to identify trends, patterns, predominant crash reasons, and high crash rate intersections. The purpose of the crash analysis is to identify locations that need to be addressed to improve safety. Data for crashes occurring between June 2007 and June 2012 was obtained from ADOT's Accident Location Identification Surveillance System (ALISS) database. During this five year period, a total of 7 crashes occurred within the study area. **Figure 17** illustrates the location and type of each crash during the analysis period.

Of the 7 crashes within the study area, analysis of the crash data found:

- 3-single vehicle, 2-rear-end, 1-rear-to-side and 1-left-turn
- 4 were non-injury crashes, 1 possible injury, 1 incapacitating injury and 1 fatality
- 2 following too close, 2 failure to stop at stop sign, 1 unknown, 1 exceeding lawful speed and 1 inattention/distraction
- All 7 crashed occurred during dry conditions
- 3 crashes occurred during daylight and 4 in the dark

Fatality crash rates were computed for roadway segments with high numbers of crashes. Crash rates for roadway segments are expressed as "crashes per 100 million vehicle miles traveled" (MVMt). The following formula was used to calculate the fatality rate:

$$\frac{100,000,000 \times \text{no. of fatalities}}{\text{ADT} \times \text{no. of years} \times 365 \times \text{length of segment}}$$

Similarly average annual total crash rates were calculated for particular segments using the following formula:

$$\frac{1,000,000 \times \text{no. of crashes}}{\text{ADT} \times \text{no. of years} \times 365 \times \text{length of segment}}$$

## Crash Rate Comparisons

The fatality crash rate for the Meridian Road study area is 0.014. This fatality rate is considerably lower than the 2005-2009 average Arizona and U.S. fatality crash rate of 1.29 and 1.13, respectively (per the 2009 Arizona Crash Facts Summary prepared by ADOT Intermodal Transportation Division). The average annual total crash rates for the Meridian Road study area segment is 0.099. This rate is predominantly lower than the 2009 Arizona and U.S. crash rates of 1.7 and 1.8, respectively (per 2009 Arizona Crash Facts Summary prepared by ADOT Intermodal Transportation Division and the Traffic Safety Facts 2009 prepared by NHTSA).

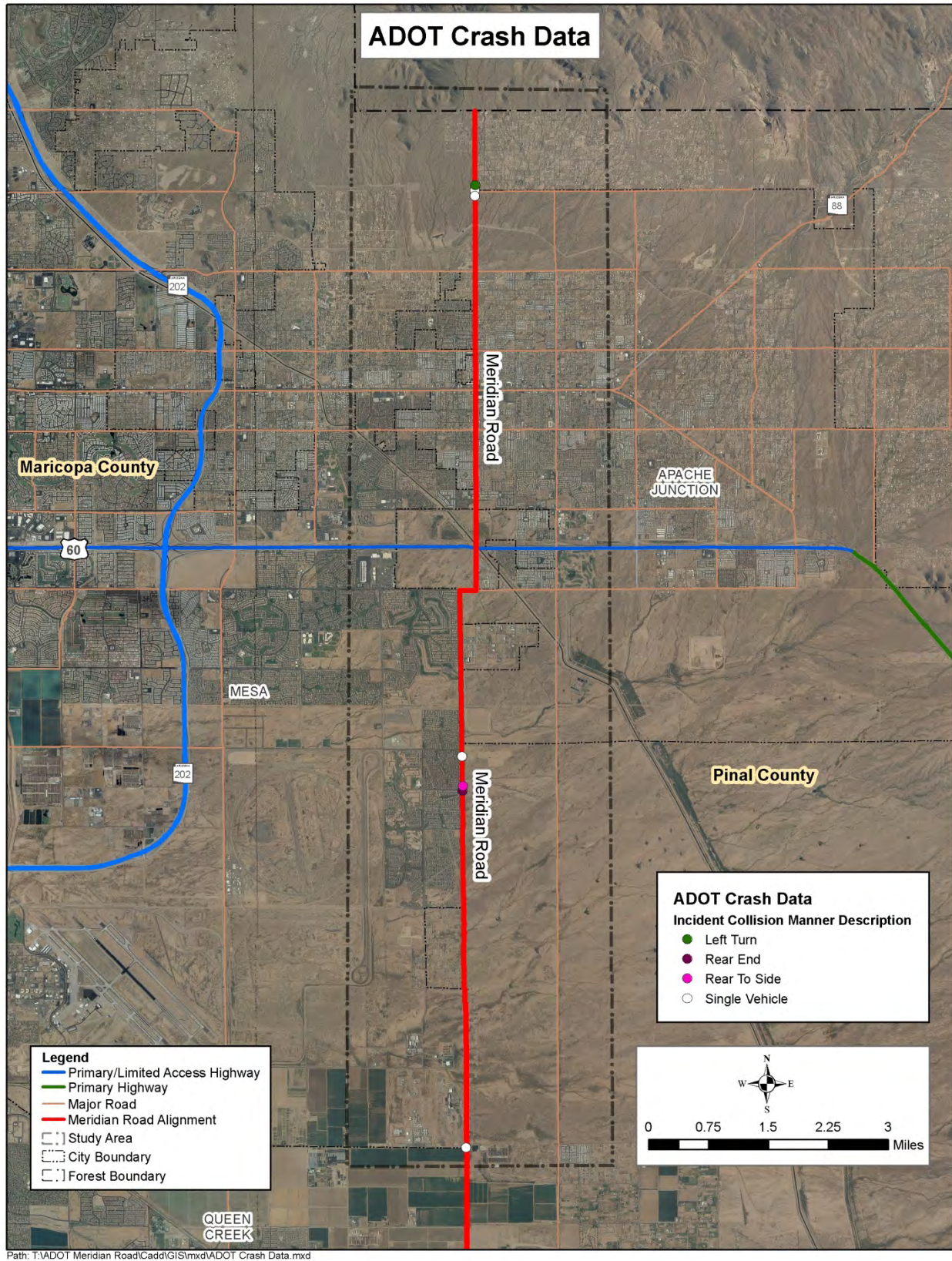

Figure 17: Crash Location and Type



## VII. Environmental Summary

This section summarizes the existing environmental conditions for the Meridian Road Corridor Study Area, which is generally bounded by Germann Road on the south, McDowell Boulevard on the north, Ironwood Road on the east and Signal Butte Road on the west. This environmental overview is not intended to meet the requirements of the National Environmental Policy Act (NEPA).

The Environmental Summary describes the study area in terms of its physical and natural, and cultural resources contexts. The study area includes lands within the City of Mesa, Apache Junction, Maricopa County, and Pinal County. The information presented is based on existing data sources from municipal, county, state, and federal agencies; and, on a “windshield” survey of the study area.

### Population Living within Study Area

The study area is predominately White with some Hispanics, African American, Asian, American Indian Alaskan Native, Native Hawaiian Pacific Islanders, and others. Based on 2010 US Census there are elderly, low-income, disabled and female heads of household populations are found in the study area; however, these groups represent a small percentage of the overall population. There are approximately 51,779 White, 1,339 African American, 1,282 Asian, 540 American Indian Alaskan Native, 141 Native Hawaiians Pacific Islanders, and 3,568 Other in the study area. There are 10,075 Hispanic and 48,962 Non-Hispanic. The approximate population is 60,768 for the Meridian Road Corridor Study Area. Four the census tracts overlap outside the study area.

### Environmental Justice

The study area contains a population of approximately 60,768 persons with an average of 85 percent being white. Title VI Environmental Justice populations are relatively low in the study area.

### Biotic Community

The majority of the study area is relatively flat with an average elevation of 1,200 feet above sea level. No permanent natural water sources exist within the study area; however, numerous ephemeral washes dissect the study area. The middle portion of the study area is dominated by creosote bushes with scattered ironwood, mesquite and palo verde. The study area provides cover and foraging opportunities for wildlife due to the presence of vegetation and ephemeral washes.

The southern portion of the study area is located in the Lower Colorado River Sonoran Desertscrub with vegetation that include honey mesquite (*Prosopis glandulosa*), ironwood (*Olneya tesota*), blue paloverde (*Cercidium floridum*), desert willow (*Chiopsis linearis*), creosotebush (*Larrea tridentata*), white bursage (*Ambrosia dumosa*), canyon ragweed (*Ambrosia ambrosioides*), indigo bush (*Psoralea schottii*), big galleta (*Hilaria rigida*), catclaw acacia (*Acacia greggii*), burrobrush (*Hymenoclea salsola*), saltbush (*Atriplex polycarpa*), and desert broom (*Baccharis sarothroides*). The northern portion of the study area is in the Sonoran Desertscrub - Arizona Upland Subdivision where vegetation generally appears similar to a



scrubland or low woodland of leguminous trees with intervening spaces held by several open layers of shrubs and perennials succulents. Species found within this subdivision include: blue paloverde, ironwood, mesquites (*Prosopis* spp.), catclaw acacia, foothill paloverde (*Cercidium microphyllum*), crucifixion thorn (*Canotia holacantha*), chollas (*Opuntia* spp.), saguaro (*Carnegie gigantea*), organ pipe (*Stenocereus thurberi*), barrel cactus (*Echinocactus horizonthanlonius*), and fishhook barrel cactus (*Ferocactus wislizenii*) (Brown, D.E., 1994).

### Wildlife

Wildlife found in the Sonoran Desertscrub (Lower Colorado River and Arizona Upland subdivisions) includes the following:

*Mammals:* Desert mule deer (*Odocoileus hemionuscrooki*), feral burros (*Equus asinus*), coyote (*Canis latrans*), javelina (*Dicotyles tajacu*), desert cottontail (*Sylvilagus auduboni*), black-tailed jackrabbit (*Lepus californicus*), ground squirrels (*Ammospermophilus* spp.), pocket mice (*Perognathus* spp.).

*Birds:* Burrowing owl (*Athene cunicularia*), quail (*Lophortyx* spp.), mourning dove (*Zenaida macroura*), doves (*Zenaida* spp.), road-runner (*Geococcyx californianus*), raven (*Covus cryptoleucus*), cactus wren (*Campylorhynchus brunneicapillus*).

*Reptiles:* Chuckwalla (*Sauromalus obesus*), common lizards (*Uma* spp.), whiptails (*Cnemidophorus* spp.), horned lizards (*Phrynosoma* spp.), rattlesnakes (*Crotalus* spp.).

*Amphibians:* Couch's spadefoot (*Scaphiopus couchii*), red-spotted toad (*Bufo punctatus*), Sonoran Desert toad (*B. alvarius*), Great Plains toad (*B. cognatus*), American bullfrog (*Ranacatesbeiana*) (Brown, D.E., 1994).

A scoping letter has been submitted to Arizona Game and Fish Department (AGFD) for any listing of threatened and endangered species in the study area. Available and existing literature review shows the study area provides suitable habitat for various native wildlife species, but does not contain suitable habitat for any federally threatened and endangered species or candidates species listed in for the southern portion of the study area south of US 60.

### Visual Character and Noise

The Meridian Road corridor is in an air nonattainment area for carbon monoxide, ozone, and particulate matter smaller than 10 microns, which have transportation control measures in the State Implementation Plans and Federal Implementation Plan.

Potential sensitive noise receivers located adjacent to the Meridian Road alignment include residences, school, and churches. Grace Community Church on Apache Trail is located approximately one quarter of mile from Meridian Road. There are four other churches between Meridian Road and Ironwood Road. The Imagine Prep at Superstition school is located south of Broadway Road near Ironwood Road. Other schools within the study area include Excalibur Charter High School at Main Street and Signal Butte, Briton Elementary School at the northwest

corner of southern Blvd and Meridian Road, and Meridian Elementary School at the northwest corner of Mountain Road and Mesquite St.

Potential sensitive noise receivers within the study area include residences located adjacent to the Meridian Road alignment. Existing noise data are not currently available for the study area. During subsequent environmental documentation activities for the study area, ambient noise levels may need to be monitored at specific locations. The future noise quality for the study area would need to be evaluated against the existing noise data to conform to the ADOT Noise Abatement Policy.

### Water Resources

Potential jurisdictional waters of the US located in the study area include several unnamed washes. These should be delineated before construction to determine the need for Sections 401 and 404 permits. The Central Arizona Project (CAP) canal traverses the study area at US 60 and Meridian Road. The area south of the Powerline Floodway is part of the East Mesa Area Drainage Master Plan which is under study. There are portions of the northern part of study area that occur within Zone A of the FEMA Flood Map.

### Section 4(f) and Section 6(f) Properties

In the newer residential development between Baseline Road and Ray Road, there are multi-use facilities as retention basins during periods of increased flooding and may function as parks, trails and recreation areas during times of reduced rainfall and water run-off. The Little League Park is located at southwest corner of Apache Trail and Ironwood.

There are numerous hiking and equestrian trails within the study area and the most northern trail is the Pass Mountain Trail within the Utery Mountain Regional Recreation Area north of McDowell Boulevard. There is also a recreational trail than runs parallel to the CAP canal which may serve as multi-use and equestrian trail.

P & M Equestrian Park is located at the northwest corner of Brown Road and Meridian Road. The project may impact the equestrian park since it is adjacent to the Meridian Road. The Superstition Air Park (park for model airplanes) is located within the large earthen bermed retention basin north of Brown Rd and east Meridian Road.

### Hazardous Materials

A review of available Arizona Department of Quality (ADEQ) databases revealed leaking underground storage tank (LUST) locations which are shown in **Table 14**.

**Table 14: Leaking Underground Storage Tank Locations**

Location	UTM	Type
At Signal Butte along West Apache Trail	X:444424, Y: 3697549	LUST
Between Meridian and Mountain Road along West Apache Trail	X: 445532, Y: 3697589	LUST
Between Meridian Road and Ironwood along West Apache Trail	X: 447071, Y: 3697589	LUST
At Ironwood along West Apache Trail	X: 447644, Y: 3697393	LUST
At Delaware Road and Broadway	X:446862, Y: 3696650	LUST
East Baseline Road east of Meridian Road	X: 446340, Y: 3693443	LUST
On West Germann Road east of Meridian Road	X: 446288, Y: 3682205	LUST

Sharon Hodges of Allands conducted the Comprehensive Environmental Response, Compensation, and Liability Information System (CERCLIS) and the Resource Conservation and Recovery Act (RCRA) database search for the property located South of McDowell Road and North of Germann Road, from Signal Butte Road to just East of Ironwood Drive, Mesa and Apache Junction, Arizona, being in Sections 1, 12, 13, 24, 25 and 36, Township 1 North, Range 7 East; Sections 5 through 8, 17 through 20, and 29 through 32, Township 1 North, Range 8 East; Sections 1, 12, 13, 24, 25 and 36, Township 1 South, Range 7 East; Sections 5 through 8, 17 through 20, and 29 through 32, Township 1 South, Range 8 East; Section 1, Township 2 South, Range 7 East; and Sections 5 and 6, Township 2 South, Range 8 East, Gila and Salt River Base and Meridian.

The CERCLIS list contains sites which are either proposed to or on the National Priority List (NPL) and sites which are in the screening and assessment phase for possible inclusion on the NPL. Those sites on the No Further Action Planned (NFRAP) list have no further remedial action planned. This database is provided by EPA dated June, 2012, and Allands searched for facilities within a 0.5 mile search distance from subject property exterior boundaries. There were no CERCLIS / NFRAP facilities found located within subject property boundaries.

Under Resource Conservation and Recovery Act (RCRA) the Environmental Protection Agency compiles a database of facilities that are involved in the generation of hazardous materials. This database is from the Arizona Department of Environmental Quality RCRAInfo Database, dated June, 2012 and Allands checked for Federal RCRA facilities located within a 0.125 mile search distance from subject property exterior boundaries. **Table 15** lists the RCRA facilities within 0.125 mile of the Meridian Road Corridor Study study area.

Table 15: Resource Conservation and Recovery Act (RCRA) Facilities

EPA ID	FACILITY	ADDRESS	NOTIFICATION DATE	STATUS
AZR000047035	Apache Junction Cancer Center	2080 W Southern Ave	3/1/2008	CEG
AZR000047034	Apache Junction Cancer Center	2080 W Southern Ave	2/23/2009	CEG
AZR000044545	EVDI Medical Imaging Ironwood	2080 W Southern Ave	1/29/2009	SQG
AZS000047480	HD Automotive & Machine Shop	2210 W Apache Trail	8/31/2004	N
AZR000500769	Statewide Environmental Oil Services	2475 W Dallas Ave	2/10/2008	N
AZR000043166	Wal Mart Store 1381	2555 W Apache Trail	3/2/2009	CEG
AZR000042374	Solvents Systems Inc	4793 S Desert View Dr	5/8/2006	N
AZE050323002	Sunbelt Tank Services	4932 S Penny Lane	6/21/2005	N
AZR000037812	MUSD 4 Pur Oper / Sousa Elem	616 N Mountain	2/14/2005	CEG
AZD982491649	TRW VSSI / TRW Vehicle Safety Systems Mesa li Facility	11202 E Germann Rd	2/3/2010	LQG / CORRACTS
AZR000506931	CMC Steel Arizona	11444 E Germann Rd	2/2/2009	N
AZE060911001	CRM Of America LLC	11400 E Pecos Rd	4/23/2008	SQG
AZR000004846	Walgreens 2963	11545 E Apache Trail	7/31/2001	N
AZR000503607	Wal-Mart Super Center 3833	1606 S Signal Butte Rd	3/2/2009	SQG
AZR000506899	Bright Now Dental	1804 S Signal Butte Rd	1/12/2009	CEG
AZR000506196	Gateway Smiles	1901 S Signal Butte Rd	1/8/2009	CEG
AZR000001016	Fuji Film Electronic Materials USA / Arch Chemicals Inc / Olin Electronic Materials	6550 S Mountain Rd	3/25/2010	LQG
AZR000002394	MGC Pure Chemicals America Inc	6560 S Mountain Rd	2/21/2008	N
AZR000046987	Top Drawer Components Apache Junction	5154 S Delaware Dr	2/17/2009	CEG

LQG: Large quantity generator (more than 1000 kg per month)

SQG: Small quantity generator (100 – 1000 kg per month)

CEG: Conditionally exempt small quantity generator (less than 100 kg per month)

N: Not a generator verified or inactive generator

## Cultural Resources

### Background Research

A site file check covering both the area identified as the project corridor and a 1-mile study area buffer was conducted. The online AZSITE Cultural Resource Database was checked. Approximately 65 archaeological projects have taken place within 1 mile of the project area; because none of them examined any portion of the project corridor within the past 10 years, no further information about these previous projects is provided herein. Twenty-five sites have been previously recorded in the review area, of which three occur within or immediately adjacent to the 200-ft-wide corridor (**Table 16**). NA15612 is a small Hohokam artifact scatter on the west side of Meridian Road between US Highway 60 and Baseline Road; AZSITE has no record of its National Register eligibility. AZ FF:9:17(ASM) is the historic US Highway 80, which follows the Apache Trail alignment across the project corridor; the site as a whole has been determined eligible under Criteria A and D, but the segment through the project corridor lacks integrity of design, setting, materials, workmanship, and feeling, so it does not contribute to the site's overall eligibility. AZ U:10:36(ASM) is a large Hohokam resource procurement site; the



western extent of the site intersects the project corridor roughly midway between Guadalupe and Elliot Roads.

AZSITE shows no historic buildings in the review area. A review of the online Maricopa County Assessor's GIS database did not identify any buildings 45 years or older on the west of the corridor. The Pinal County Assessor Office does not maintain a similar online database so additional research would be required to determine if any buildings on the east side of the corridor are historic.

**Table 16: Summary of Previously Recorded Cultural Resources within the Study Area**

Agency Site No.*	Site Type	Eligibility Recommendation
NA15611	Hohokam artifact scatter	No data
<b>NA15612</b>	Hohokam artifact scatter	No data
NA15613	Historic homestead	No data
<b>AZ FF:9:17(ASM)</b>	Historic US Highway 80	Determined eligible (Criteria A and D)
AZ U:10:7(ASM)	Historic habitation site	Not evaluated
AZ U:10:12(ASM)	Hohokam artifact scatter	Not evaluated
AZ U:10:12(ASU)	Hohokam artifact scatter	No data
AZ U:10:13(ASM)	Hohokam artifact scatter	Not evaluated
<b>AZ U:10:36(ASM)</b>	Hohokam resource procurement site with artifact scatter and 32 roasting pits	Recommended eligible (Criterion D)
AZ U:10:37(ASM)	Hohokam artifact scatter with rock pile	Recommended eligible (Criterion D)
AZ U:10:38(ASM)	Hohokam sherd scatter with rock scatter	Unknown
AZ U:10:40(ASM)	Hohokam sherd scatter with rock scatter	Unknown
AZ U:10:41(ASM)	Hohokam artifact scatter	Unknown
AZ U:10:45(ASU)	Hohokam sherd scatter	No data
AZ U:10:78(ASM)	Hohokam artifact scatter	Recommended eligible (Criterion D)
AZ U:10:79(ASM)	Hohokam artifact scatter	Recommended eligible (Criterion D)
AZ U:10:80(ASM)	Hohokam artifact scatter	Recommended eligible (Criterion D)
AZ U:10:104(ASM)	Hohokam artifact scatter	Recommended eligible (Criterion D)
AZ U:10:105(ASM)	Hohokam artifact scatter	Recommended eligible (Criterion D)
AZ U:10:137(ASM)	Hohokam artifact scatter	Recommended not eligible
AZ U:10:139(ASM)	Hohokam artifact scatter	Recommended eligible (Criterion D)
AZ U:10:151(ASM)	Hohokam artifact scatter	Determined not eligible
AZ U:10:178(ASM)	Hohokam artifact scatter	Recommended not eligible
AZ U:10:179(ASM)	Hohokam artifact scatter with rock cluster	Recommended not eligible

*Bold indicates sites within or immediately adjacent to the project corridor*

### Windshield Survey

A windshield survey of the project area was conducted on July 26, 2012 by Kristin Fangmeier. The entire length of the corridor was driven in both directions except where access was restricted by fences or no paved or dirt road existed. **Table 17** describes the current conditions along the project corridor. North of US 60, much of the project corridor is developed and

Meridian Road is paved; south of US 60, Meridian Road is largely unpaved and crosses through mostly undeveloped land.

**Table 17: Summary of Current Corridor Conditions**

Northern Crossroad	Southern Crossroad	Current Corridor Conditions	Recommendations for Further Work
McDowell Boulevard	McKellips Boulevard	Paved two-lane road with bladed shoulders. Some adjacent parcels are developed but corridor along road is largely natural vegetation (60 percent).	Conduct Class III survey of undeveloped areas
McKellips Road	Lost Dutchman Boulevard	Paved two-lane road with bladed shoulders. Some adjacent parcels are developed but corridor along road is largely natural vegetation (80 percent).	Conduct Class III survey of undeveloped areas
Lost Dutchman Boulevard	Superstitions Boulevard	Paved two-lane road with bladed or landscaped shoulders. Widens to include center turn lane south of Smoketree Street. Widens to four lanes with center turn lane and right-turn lane north of University Drive. Most adjacent parcels are developed but corridor along road has some natural vegetation (40 percent).	Conduct Class III survey of undeveloped areas
Superstitions Boulevard	Broadway Avenue	Paved two-lane road with bladed or landscaped shoulders. Widens to four lanes with center turn lane near intersections at each end and at Apache Trail. Adjacent parcels are developed with little to no natural vegetation (less than 10 percent).	No further work
Broadway Avenue	Southern Avenue	Paved two-lane road with bladed or landscaped shoulders, with occasional right turn lanes. Widens to four lanes with center turn lane near intersection at Broadway Road. Most adjacent parcels are developed with no natural vegetation, but a small section (approx. 500 ft long) on both sides of road north of Southern Avenue is undeveloped.	Conduct Class III survey of undeveloped area north of Southern Ave.
Southern Avenue	Baseline Road	Paved two-lane road with bladed shoulders. Few adjacent parcels are developed so majority of project corridor is open (80 percent).	Conduct Class III survey of undeveloped area
Baseline Road	Guadalupe Road	Corridor not accessible (fenced off) but aerial imagery shows moderate disturbance. Some adjacent development.	Conduct Class III survey
Guadalupe Road	Elliot Road	Northern half not accessible but aerial imagery shows moderate disturbance (blading and/or dirt road). Southern half is paved two-lane road with center turn lane. Shoulder is landscaped on west side (back of residential development) and bladed on east side (undeveloped).	Conduct Class III survey of undeveloped areas
Elliot Road	Warner Road	Paved two-lane road with center turn lane. Shoulder is landscaped on west side (back of residential development) and bladed on east side (undeveloped).	Conduct Class III survey of undeveloped areas

**Table 17: Summary of Current Corridor Conditions (continued)**

Northern Crossroad	Southern Crossroad	Current Corridor Conditions	Recommendations for Further Work
Warner Road	Ray Road	North half is paved two lane road. Shoulder is landscaped on west side (back of residential development) except parcel at southwest corner of intersection at Warner Road and bladed on east side (undeveloped). South half is inaccessible but aerial imagery shows moderate disturbance (blading and/or dirt road) between residential development and undisturbed desert.	Conduct Class III survey of undeveloped areas
Ray Road	Williams Field Road	Bladed dirt road or two-track through disturbed but largely undeveloped desert. Some houses along the road.	Conduct Class III survey of undeveloped areas
Williams Field Road	Pecos Road	Bladed dirt road or two-track through disturbed but largely undeveloped desert. Some houses along the road.	Conduct Class III survey of undeveloped areas
Pecos Road	Germann Road	Bladed dirt road or two-track through disturbed but largely undeveloped desert. Some adjacent development.	Conduct Class III survey of undeveloped areas

**Recommendations for Further Cultural Resource Work**

Based on the results of the desktop search of the AZSITE database, the Meridian Road corridor has not been surveyed within the past 10 years. The windshield survey revealed that the corridor occurs in a mixed urban and rural environment; although portions of the corridor have been developed, others contain largely undisturbed desert. Therefore, it is recommended that the undeveloped areas within the project corridor be subject to a Class III pedestrian survey to identify any previously recorded cultural resources. It is possible that AZ U:10:36(ASM) will require mitigation prior to construction; NA15612 may also require additional work if the survey determines that the site extends into the project corridor. It is unlikely that AZ FF:9:17(ASM) will require further work due to the lack of integrity; it is recommended that a formal evaluation of the historic highway alignment be conducted at the time of the Class III survey. In addition, a historic building assessment is recommended to determine if any standing buildings 45 years or older occur along the project corridor.

**VIII. Future Conditions**

The following sections provide an inventory of future conditions within the study area.

**Flood Control District Channels**

As part of an update of the Area Drainage Master Plan (ADMP), the Flood Control District of Maricopa County (FCDMC) is studying a number of options for drainage and capacity issues. The study area is divided into three somewhat independent zones which include three proposed alternatives for consideration. These are summarized below:

*ADOT SR 24 Zone:*

The SR 24 Zone includes the contributing area between the Powerline Floodway and the future State Route 24 (SR 24) freeway. The future freeway drainage system is the back bone of this zone and will intercept runoff and convey it to the Powerline Floodway. The remaining drainage issues are concentrated between the Mountain View Road and Meridian Road alignments from Ray Road on the north to Williams Field Road on the south. Significant runoff generated in Pinal County combines with local flow and floods large tracks of land and impedes traffic and local access. Three alternatives have been developed for this area. Alternative 1 includes an interceptor channel along Meridian Road south of Ray Road to SR 24 along with an interim detention basin within the SR 24 right-of-way. Alternative 2 is similar to Alternative 1 except the detention basin would be permanent and be located further north at Galveston Road. Alternative 3 addresses more frequent, smaller flooding, rather than the 100-year protection of the regional issues. The components of this alternative include a series of roadside channels which discharge into an existing channel.

*Ellsworth Zone:*

This zone extends from the proposed SR 24 freeway to Queen Creek Road and includes the drainage area contributing to the exiting Ellsworth Channel which has capacity concerns. Other drainage issues include chronic flooding along Pecos Road. Three alternative solutions have been recommended for this zone. Alternative 1 includes channels along Meridian Road from the proposed SR 24 to Queen Creek Road together with a channel along Pecos Road. A detention basin is also proposed at the intersection of Meridian Road and Pecos Road as well as at Pecos Road and Ellsworth Road. Alternative 2 is similar to Alternative 1 except that the Pecos Road Channel is offset from the road to follow historic drainage patterns and the basin at the intersection Pecos Road and Ellsworth Road is eliminated. Alternative 3 is again similar to Alternative 1 except a portion to the Pecos Road Channel is shifted a quarter mile to the south and would require some modification to the existing Ellsworth Channel.

*Rittenhouse Zone:*

The Rittenhouse Zone includes the area from Germann Road to Queen Creek Road and deals with drainage complaints along Germann Road and capacity concerns with the Rittenhouse Channel. As with the other zones three alternatives have been developed to alleviate the drainage problems. Alternative 1 includes regional channels on Germann Road and Queen Creek Road from Meridian Road to the existing Rittenhouse Channel along with lateral channels connecting the two channels. Detention basins along each regional channel will also be included. Alternative 2 replaces the Germann and Queen Creek channels with a single channel roughly following historic flow paths. Several lateral channels will also be included to convey flow into the main regional channel. Similar to Alternative 1, Alternative 3 eliminates the detention basins and instead recommends that a future development would be subject to a higher retention requirement. The alternative will include the preservation of some agricultural land within the drainage area to reduce overall runoff.



The proposed channels for the regional facility will be constructed with 8:1 landscaped slopes with a low-flow movable bed channel. This will produce a top width of approximately 125 feet. Combined with the roadway right-of-way this gives an overall width of around 250 feet. Potential conflicts arise on how to best center the proposed channel and roadway to make best use of the existing right-of-way, limit conflicts with existing properties and limit land take within Pinal County. The majority of the land adjoining Meridian Road in Pinal County is owned by Arizona State Land Department (ASLD). ASLD will advocate that the channels be designed for post development conditions; enabling them to potentially waive on-site detention. This would give ASLD an incentive to participate in the regional system. However, FCDMC assumes the post development condition will include on-site detention, therefore allowing for a smaller regional facility. It will be incumbent for the designers to coordinate the roadway alignments and cross sections with ASLD and FCDMC as well as other project partners.

### **Future Recreation Trails, Parks/Areas and Open Space**

The *City of Apache Junction 2010 General Plan Park and Recreation Implementation Plan* states plans for expansion of Prospector Park, development and implementation of community parks, neighborhood parks, trails and open spaces, and special use facilities within the Portalis and Superstition Vistas Communities, development and implementation of a master plan for Siphon Draw Park, and expand and implement non-motorized trails and open spaces guidelines within the City. One future community park is planned at Elliot Road and Meridian Road.

The *City of Mesa 2025 General Plan* shows three future neighborhood parks within two miles of Meridian Road at Crismon Road and Brown Road, Signal Butte Road and Baseline Road, and Crismon Road and Ray Road. The City is also proposing a community park and metro park at Signal Butte Road and Guadalupe Road and a metro park at Crismon Road and Brown Road.

### **Future Multimodal Transportation**

The City of Mesa is proposing to expand the express bus route along US 60 east past Meridian Road. The City is proposing that Main Street east of the light rail terminus to Meridian Road become a transit priority corridor. A transit priority corridor will provide enhanced bus service and can improve level of service within the corridor by improving intersection capacity and providing buses a dedicated or shared lane with assigned traffic signal priority. Local bus routes along major crossroads between McKellips Boulevard and Southern Avenue was expanded from Power Road to Ellsworth Road. Local bus routes along Baseline Road are proposed to be expanded from Power Road to Signal Butte Road. New local routes are proposed for all major crossroads south of Baseline Road. The City of Mesa is also proposing new bike lanes along Meridian Road south of Baseline Road as well as along all major crossroads between Brown Road and Germann Road in the vicinity of the study area.

The City of Apache Junction is proposing a local bus route along Meridian Road from University Drive/Superstition Boulevard to Baseline Road. This transit route would provide additional service to the area bounded by Meridian Road to the west, Apache Trail to the north, Ironwood Road on the east, and Baseline on the south that has a high combined residential and employment density. Wal-Mart, the County/DMV office, City Hall, mixed use center and a

transit hub are significant trip generators located along the proposed route. The City is proposing bike lanes or bike paths along Tepee Street, Apache Trail, and 16<sup>th</sup> Avenue (half mile south of Broadway Avenue) in the vicinity of the study area. An equestrian route is proposed a quarter mile south of Lost Dutchman Boulevard in the vicinity of the study area.

## IX. Future Socioeconomic Data

### Planned Land Use

Located between Meridian Road and Signal Butte Road in Mesa is the Master Planned Community of Bell Via, which incorporates a mix of residential densities ranging from four to six units to the acre. The Portalis development (formerly Lost Dutchman Heights) is 7,700 acres of State Trust Land set to be developed as a master planned community. It is estimated that full build out will be 2045 with 39,000 units of future residential development and a population of 90,000 residents, 6-8 million square feet of future commercial building development and 250+/- acres of light industrial/business park development with 24,000 employees.

Superstition Vistas includes 175,000 acres of raw desert land held in trust by the Arizona State Land Department situated east of Meridian Road and extending to US60. The area is designed as an integrated master planned community featuring housing, employment centers and interconnected transportation system. Though the region would benefit from Superstition Vistas' capacity to handle future growth, the extent of development of Superstition Vistas depends immediately on State Trust Land policy and actions and the delivery of adequate infrastructure. Without adequate transportation infrastructure the growth of Superstition Vistas will stall. Economic development is necessary for Superstition Vistas' future growth, though the degree to which this area can reach its economic development potential will depend on adequate transportation infrastructure. Depending on future growth rates the estimated population will be between 250,000 and 1 million.

### Future Land Development within the Corridor

Future growth along and within the study area is expected to respond to three key development related influences. Most prominently in Mesa is the conversion of the Phoenix-Mesa Gateway Airport from a general aviation airport to a reliever commercial facility for Sky Harbor International Airport in Phoenix. This has triggered further significant commercial and residential expansion not only for the southeast valley, but northern Pinal County as well. Complementing the transition and development of this aviation facility is the construction of the SR 24 Freeway. This limited access roadway is expected to accommodate new residential growth in the southeast valley and to generate substantial commercial, office, and industrial opportunities at its intersection with primary arterial roadways in the area. General Motors (GM) operated a 5,000-acre proving ground and research facility. Closure of the proving grounds operations will lead to redevelopment and disposition of this property in various configurations that include both residential and employment opportunities. The Mesa Gateway Strategic Development Plan shows blended residential along with medium-high density residential and

urban centers at strategic node points within the research facility. Furthermore, Mesa's adopted General Plan also identifies a substantial amount of land for light and general industrial development. This is in response to the expansion of services at Williams Gateway Airport and reflects the anticipated employment development within this region.

On the east side of the Meridian Road corridor in Pinal County, future land uses are recommended to occur in a much more generalized manner. The Pinal County Comprehensive Plan permits both flexibility and innovation for future development. Anticipating continued annexation and subsequent development in the area near the incorporated City of Apache Junction. The goal of this area is to retain large tracts of rural parcels in single ownership so that master planned communities can be devolved in the future along with the establishment of roadways, service areas and other infrastructure improvements. This is typified by the planned region area known as Superstition Vistas, in northern Pinal County, which is expected to create additional internal and external trips within the study area.

Pinal County's Land Use Plan also shows an employment corridor between Williams Field Road and Pecos Road. A High Intensity Activity Center, Williams Gateway Freeway Activity Center, is located at Ironwood Road between Williams Field Road and Pecos Road. The Williams Gateway Freeway Activity Center includes medium and high density residential development. Build out population associated with this residential development could accommodate approximately 21,000 people. Approximately 300 acres of various employment types are also identified for planning purposes that could result in the potential for 29,000 jobs in this area. **Figure 18** shows the future land uses within the study corridor.

### **Population and Employment**

In 2010, the total residential population within the boundaries of the project influence area includes nearly 210,000 people within the three jurisdictions of Mesa, Apache Junction and Queen Creek and the two counties of Pinal and Maricopa that encompass the area. The area of influence is generally bounded by McDowell Boulevard to the north, Germann Road to the south, US 60 to the east, and SR 202L to the west. By the year 2031, the resident population in the influence area is expected to grow more than 250 percent, reaching nearly 583,000 residents. The most dramatic population gain among the jurisdictions and the counties is expected to occur in Pinal County. The majority of this area is currently owned by the Arizona State Land Department, and includes Portalis and Superstition Vistas master planned communities. The future development of these communities will trigger a population jump from approximately 34,300 in 2010 to nearly 240,000 in 2031. Significant population increases in Apache Junction, Mesa, Pinal County and Queen Creek are also reflected in **Table 18**.

Job growth in the area of influence is also expected to rise through the year 2031 and will generally follow the pattern of growth for residential population. Nearly 43,700 jobs currently exist within the project influence area, a majority of which are contained in the industrial and commercial core of southeast Mesa. However, as the Williams Gateway Airport and SR 24 Freeway corridor continues to develop, future jobs will locate on the eastern portion of the corridor as well. Pinal County, which is estimated to produce the greatest rise in resident

population, will also exhibit the greatest gain in job growth. Currently, approximately 2,800 jobs exist in Pinal County. The county only captured six percent of the total jobs located within the entire project influence area. In 2031, the approximate 24,500 jobs expected to exist in Pinal County will account for 12.5 percent of the total study area employment. Queen Creek, Mesa, and Apache Junction are all expected to experience significant employment gains.

**Table 18: Project Influence Area Population Projections**

MPA	Total Population Observed in 2010 Census	Total Population Projected for 2010	Total Population Projected for 2025	Total Population Projected for 2031
Apache Junction	42,570	75,186	134,424	151,419
Mesa	137,170	128,639	163,436	171,912
Pinal County	14,243	34,339	181,212	223,632
Queen Creek	13,233	15,611	32,052	36,322
<b>TOTAL</b>	<b>207,216</b>	<b>253,775</b>	<b>511,124</b>	<b>583,285</b>

Source: MAG 2007 Socioeconomic Projections

Note: Populations are for the portions of the MPA that falls in the Meridian Road Corridor study area only



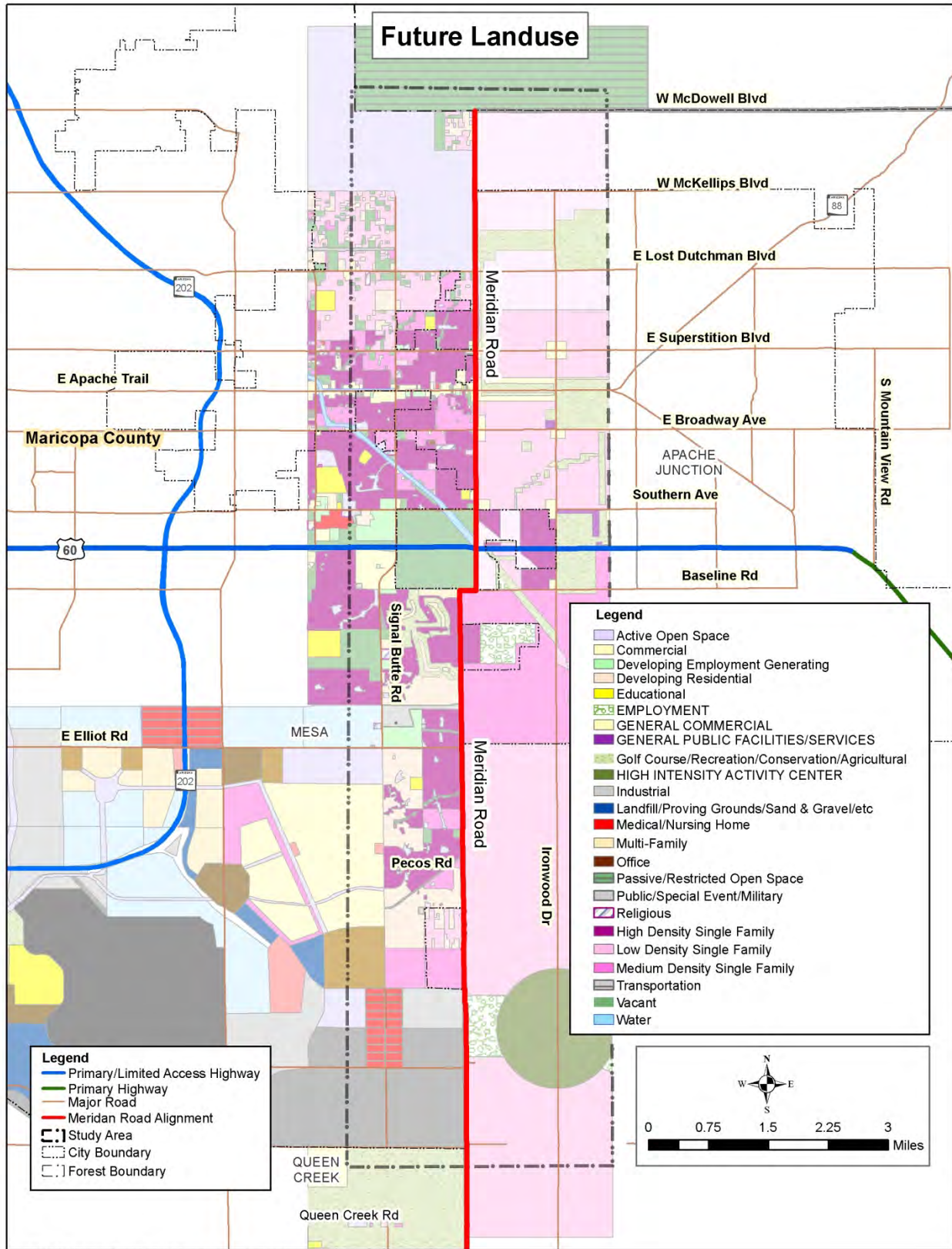

Figure 18: Future Land Use

## X. Future Traffic Volumes

Characteristics of the future transportation network were developed after reviewing relevant plans and studies described in the section of this report titled **Summary of Existing Plans and Studies**. The specific studies used to determine practical 2025 and 2035 traffic volumes were the *MCDOT Meridian Road Access Control and Corridor Improvement Study* and the *Apache Junction Comprehensive Transportation Study*. MAG's 2025 and 2035 travel demand forecasts were also reviewed to determine 2025 and 2035 future traffic volumes.

After review of the *MCDOT Meridian Road Access Control and Corridor Improvement Study* it was determined that the roadway network south of the US 60 was not consistent with more current plans and studies. 2025 and 2035 traffic volumes on the major streets crossing Meridian Road were significantly different between the MCDOT study and the MAG models. These differences are likely due to the planned changes in roadway network since the MCDOT study was completed. Therefore the MAG models for 2025 and 2035 traffic volumes were used for this study for traffic volumes south of the US 60. After review of the MAG 2025 travel demand model north of the US 60, it was noted that the traffic volumes decreased from 2025 to 2035 and did not show good agreement with the traffic volume in the *Apache Junction Comprehensive Transportation Study*. Between the MAG 2025 model and the MAG 2035 model, two miles of McKellips Boulevard between Meridian Road and Crismon Road was opened thus changing the dynamics of the traffic flow in that area. Under the MAG 2025 model roadway network, traffic heading from the northwest and desiring to go to the southeast (or vice versa) is forced onto Brown Road/Lost Dutchman Boulevard due to McKellips Boulevard not extending west past Meridian Road. With the opening of this segment of McKellips Boulevard under the MAG 2035 model, this route became the shortest path for the model to send the traffic along. A significant amount of the demand was shifted from Brown Road/Lost Dutchman Boulevard to McKellips Boulevard thus reducing the estimated volumes along Brown Road/Lost Dutchman Boulevard from 2025 to 2035. After review of the relevant studies and plans collected, it did not appear that McKellips Boulevard will extend west of Meridian Road; therefore, the traffic volumes from the *Apache Junction Comprehensive Transportation Study* were utilized for this study north of US 60. This information led to the development of the assumed future year 2025 and 2035 roadway network and the 2025 and 2035 daily traffic volumes shown in **Table 19** and graphically in **Figure 19** and **Figure 20**, respectively. Turning movement volume forecasts are shown in **Figure 21** and **Figure 22**, respectively for 2025 and 2035.

**Table 19: 2025 and 2035 Daily Traffic Volumes**

Meridian Road Segment	Direction	2025 ADT	2035 ADT
McDowell Road to McKellips Boulevard	NB	0-5,000*	0-5,000*
	SB		
McKellips Boulevard to Brown Road/Lost Dutchman Boulevard	NB	0-5,000*	0-5,000*
	SB		
Brown Road/Lost Dutchman Boulevard to University Drive/Superstition Boulevard	NB	0-5,000*	5,001-10,000*
	SB		
University Drive/Superstitions Boulevard to Apache Trail	NB	5,001-10,000*	10,001-20,000*
	SB		
Apache Trail to Broadway Road	NB	5,001-10,000*	10,001-20,000*
	SB		
Broadway Road to Southern Avenue	NB	5,001-10,000*	10,001-20,000*
	SB		
Southern Avenue to US 60	NB	10,001-20,000*	20,001-30,000*
	SB		
US 60 to Baseline Road	NB	14,315	14,761
	SB	14,709	15,129
Baseline Road to Guadalupe Road	NB	12,087	12,445
	SB	12,070	12,434
Guadalupe Road to Elliot Road	NB	6,664	5,878
	SB	6,618	5,994
Elliot Road to Warner Road	NB	14,945	13,251
	SB	14,621	13,376
Warner Road to Ray Road	NB	9,647	8,312
	SB	8,666	8,339
Ray Road to Williams Field Road	NB	8,835	9,355
	SB	7,775	9,473
Williams Field Road to SR 24	NB	12,846	4,413
	SB	12,516	5,347
SR 24 to Pecos Road	NB	10,556	15,484
	SB	10,226	16,181
Pecos Road to Germann Road	NB	6,516	10,751
	SB	6,076	11,586

\* ADT range as shown in the Apache Junction Comprehensive Transportation Study for population levels 2 & 3

The 2025 and 2035 average daily traffic level of service was determined using the same methodologies as discussed in the section of this report titled **Existing 2012 Level-of-Service**. The number of lanes depicted in the MAG models were used to determine the LOS. MAG

indicated a three lane section for Meridian Road in 2025 and 2035 within the study area. The LOS thresholds used for a two lane undivided roadway were adjusted by 5% to account for the center lane or exclusive left turn lanes as shown in **Appendix B**.

The 2025 and 2035 average daily traffic LOS within the study area are shown in **Figure 23** and **Figure 24**, respectively.



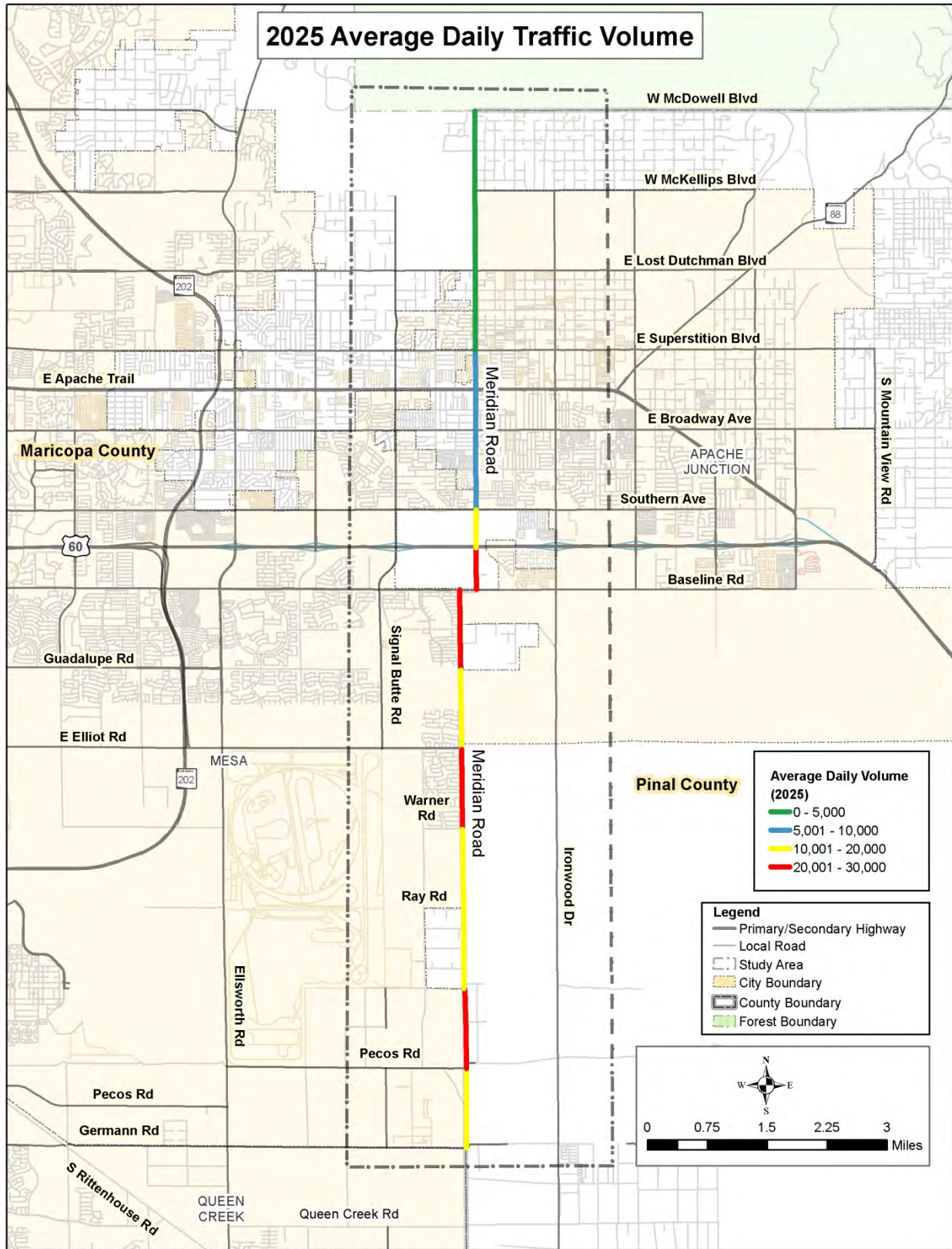

Figure 19: 2025 Daily Traffic Volumes

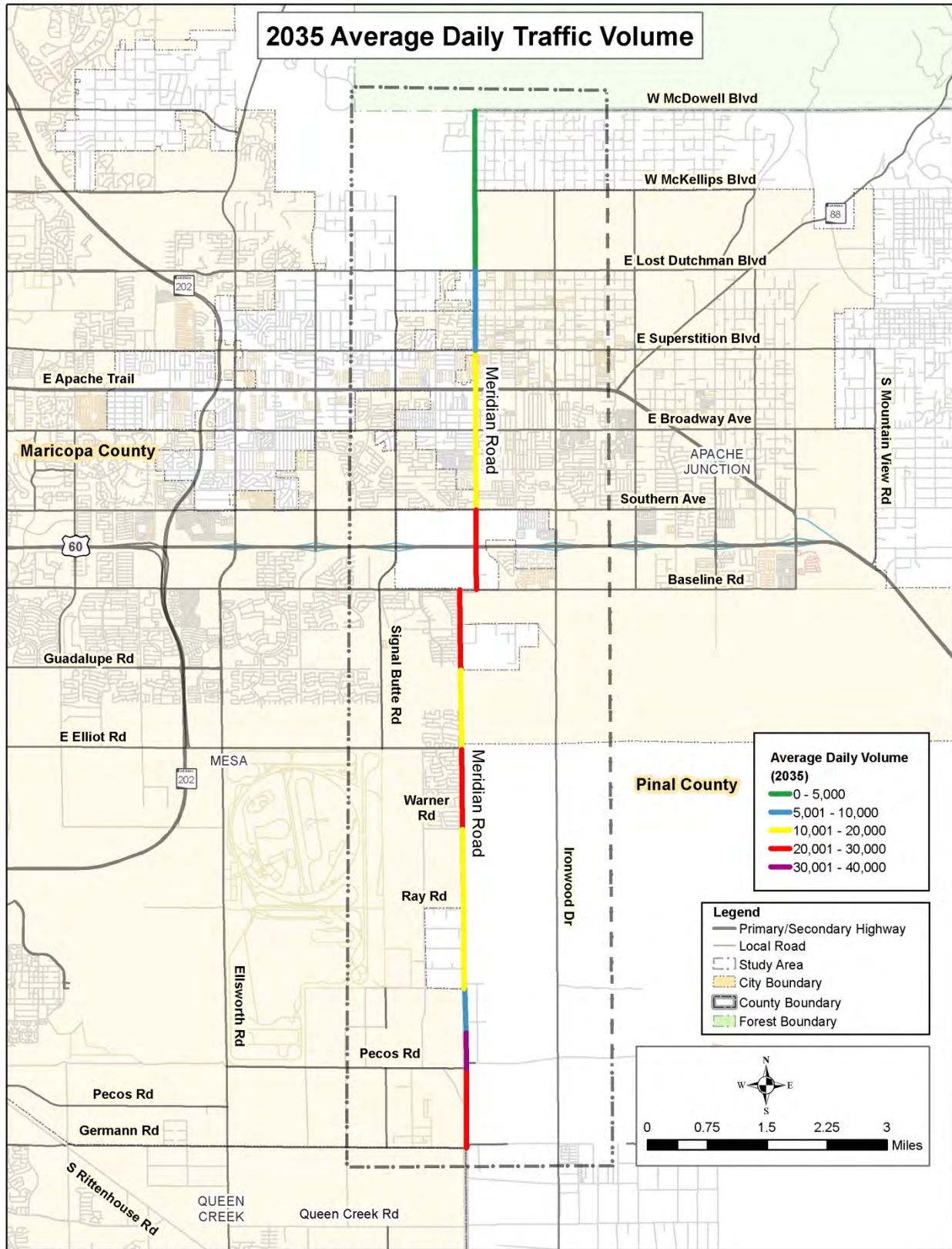
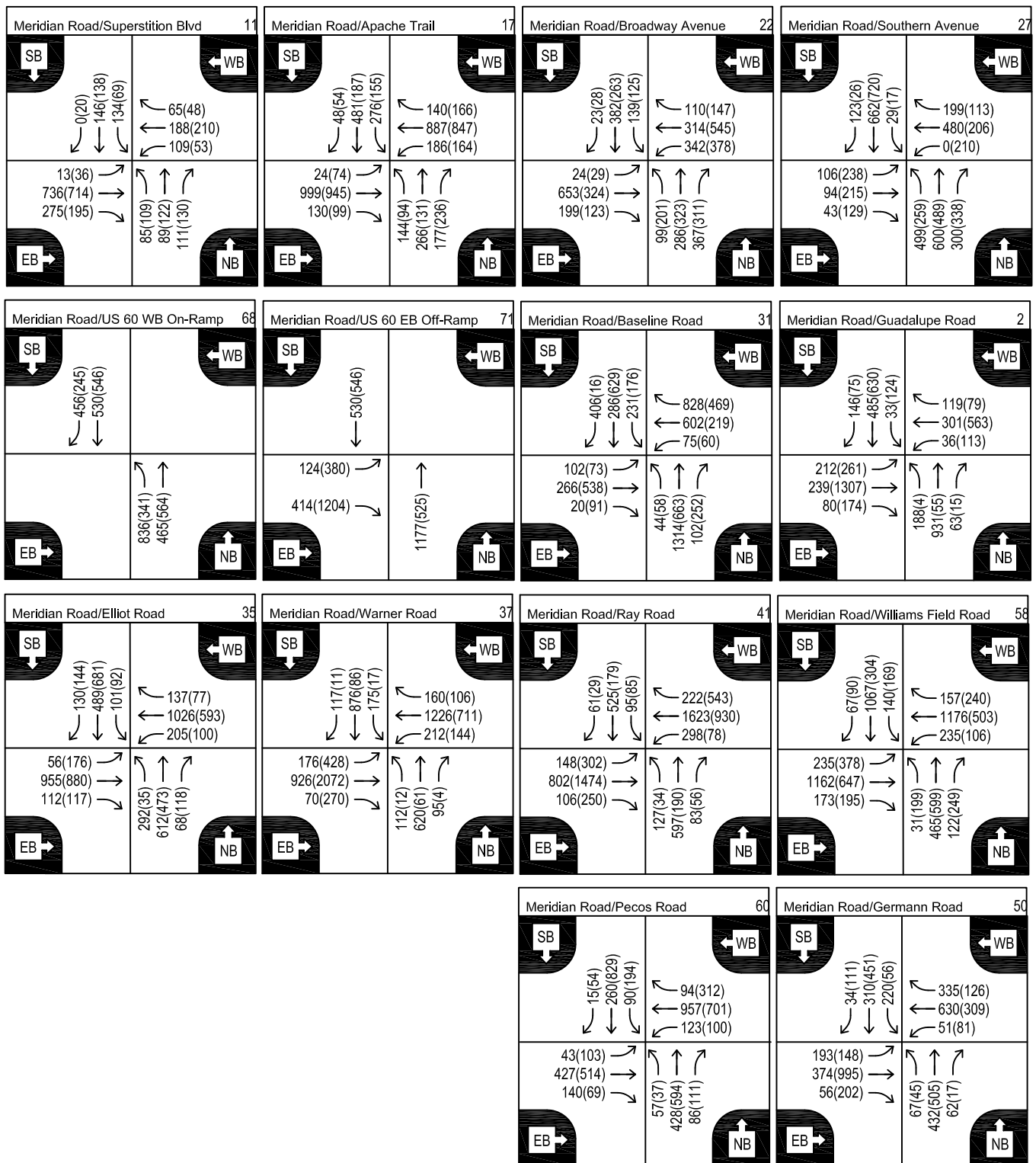

Figure 20: 2035 Daily Traffic Volumes





**Legend**  
 ← AM (PM) Peak Hour Volume

Figure 21  
 2025 Turning Movement Volumes

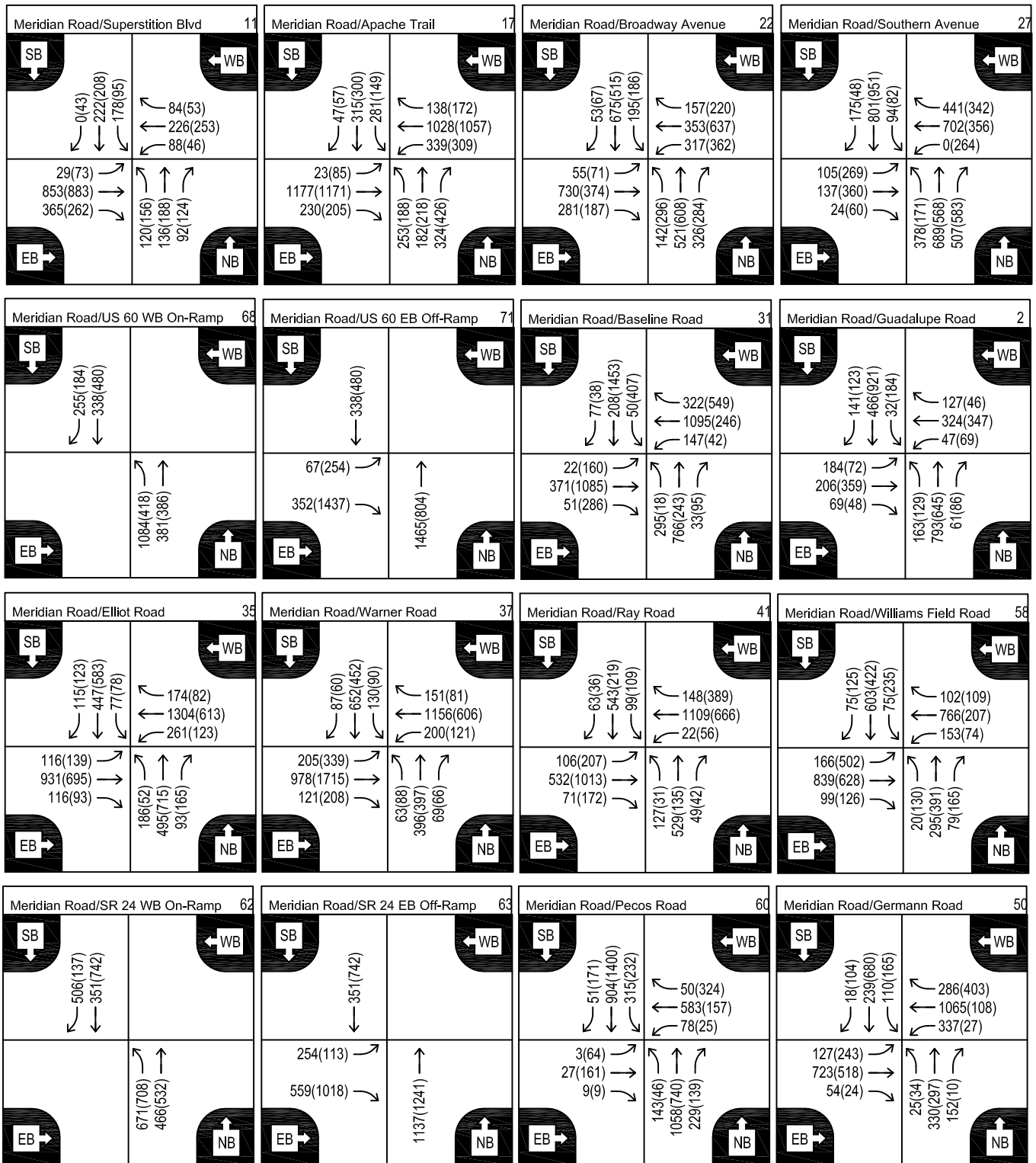

**Legend**  
 ← AM (PM) Peak Hour Volume

Figure 22  
 2035 Turning Movement Volumes



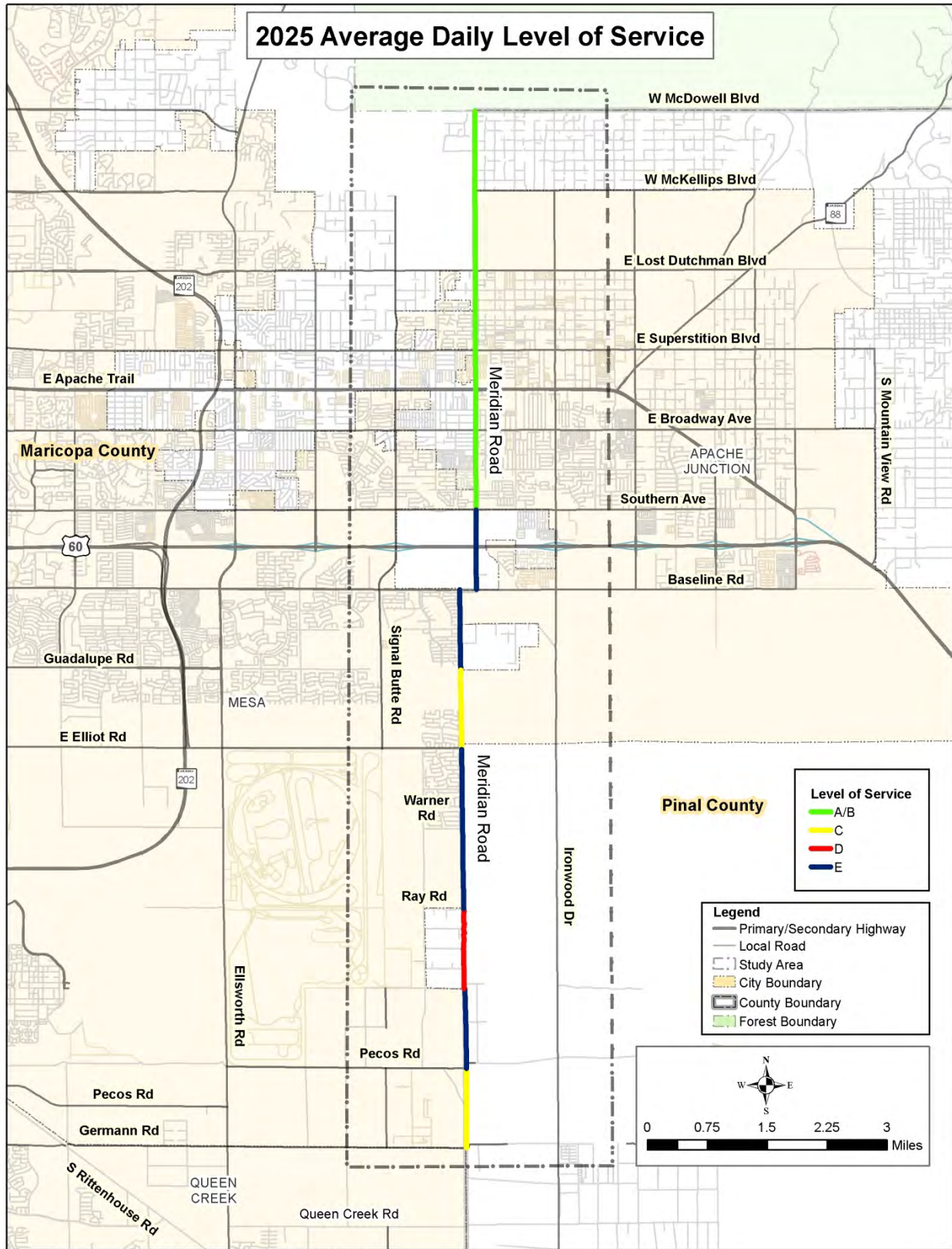

Figure 23: 2025 Average Daily Traffic Level of Service

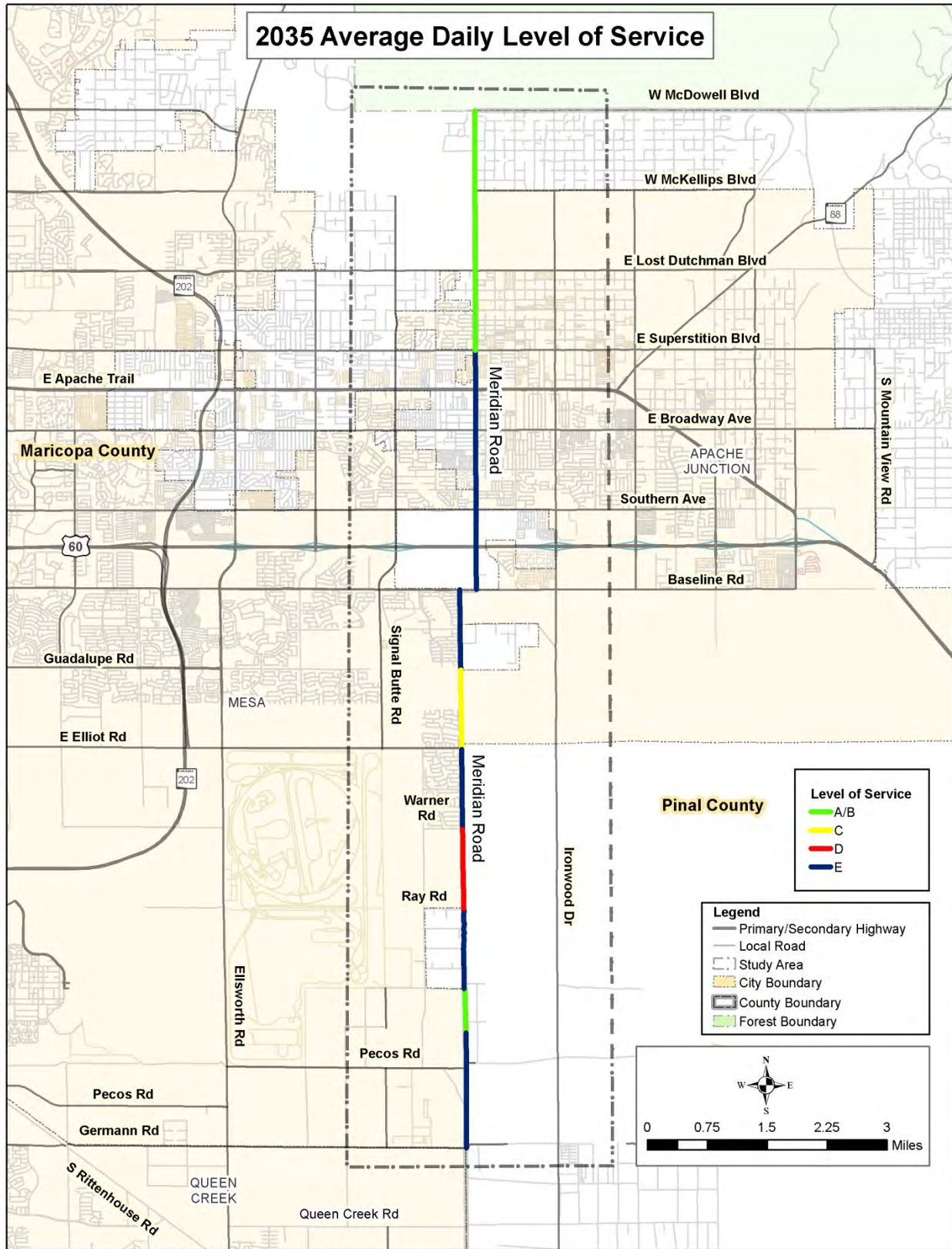

Figure 24: 2035 Average Daily Traffic Level of Service



## XI. Roadway Network Deficiencies

### 2025 Lane Deficiencies

Meridian Road between McDowell Boulevard and Southern Avenue is anticipated to operate at an acceptable LOS as a three-lane roadway in 2025. South of Southern Avenue, Meridian Road is expected to operate with poor LOS in 2025 as a three-lane roadway to Pecos Road. The segment of Meridian Road between Guadalupe Road and Elliot Road and the segment between Pecos Road and Germann Road operate with acceptable LOS in 2025 as a three-lane roadway.

### 2035 Lane Deficiencies

Meridian Road between McDowell Boulevard and Superstition Boulevard is anticipated to operate at an acceptable LOS as a three-lane roadway in 2035. South of Superstition Boulevard, Meridian Road is expected to operate with poor LOS in 2035 as a three-lane roadway to Germann Road with the exception of the segment between Guadalupe Road and Elliot Road and the ½ mile segment just south of Williams Field Road which are expected to operate with acceptable LOS in 2035 as a three-lane roadway.

### Pavement Deficiencies

MCDOT's evaluation of the existing pavement has indicated that the roadway conditions range from good to poor. Furthermore, significant crack sealing has taken place along most of Meridian Road between Baseline Road and McDowell Road/Boulevard leading to an international roughness rating of over 220 which is categorized as 'very rough'. Some of these deficiencies will be addressed with the completion of pavement preservation project programmed in FY13.

### Transportation Deficiencies

The development of the Meridian Road Corridor will be impacted by the following structures and features:

*US 60 Overpass:* The existing overpass structure at the US 60 presently carries traffic on Meridian Road across the US 60. The structure is approximately 60 feet wide and 425 feet long.

*US 60 Traffic Interchange at Meridian Road:* An interchange is planned for Meridian Road at US 60 with construction scheduled for a start in summer 2013. Initially ADOT is proposing to construct an interim, partial interchange. The design will consist of on and off ramps to the west of Meridian Road. In the interim condition no improvements will be made to the existing structure over the US 60. The bridge will accommodate one 11ft and one 14ft lane in each direction along with a 5ft sidewalk. Meridian Road will be widened to the north of US 60 to accommodate four through lanes plus two left turn lanes. Similarly to the south the road will be widened to four through lanes and will be tapered back to the existing road width as soon as possible.

A full traffic interchange to accommodate a six lane divided Meridian Road will necessitate the construction of a new structure which will have to provide for a new 14ft clearance requirements over the CAP canal.

*Central Arizona Project Canal:* The CAP canal crosses US 60 and Meridian Road diagonally at the overpass. The CAP canal and appurtenant facilities are important considerations in constructing an interchange at this location.

*Powerline Floodway:* The Powerline Floodway crosses the Meridian Road alignment diagonally just south of the Warner Road alignment. The floodway is operated and maintained by the FCDMC and is an earthen-lined channel flowing northeast to southwest across the Meridian Road alignment.

*Diversion Dike:* An old, existing diversion dike exists between Pecos Road and Germann Road in the vicinity of the Meridian Road alignment. The dike diverts surface water flow from a defined wash east of the Meridian Road alignment to provide flooding protection for a manufacturing facility west of the Meridian Road alignment and just north of Germann Road.

*US 60 Widening:* Crismon Road to Meridian Road – US 60 is planned to be widened from four lanes to six lanes from Crismon Road to Meridian Road in Phase 3 of the MAG Regional Transportation Plan (2015-2020).

*Gateway Freeway (SR 24):* The SR 24 corridor is located in southeast Mesa and northwest Pinal County. The freeway would begin at Loop 202 near the Hawes Road interchange and extend southeasterly into Pinal County and connect to US 60 or SR 79 north of the Florence Junction. The SR 24 study area lies within or adjacent to the jurisdictional boundaries of the cities of Mesa and Apache Junction, the Towns of Queen Creek and Gilbert, and unincorporated portions of Maricopa and Pinal Counties. The section from Loop 202 to Meridian Road is in Phase 3 of the MAG Regional Transportation Plan (2015-2020). The proposed route crosses Meridian Road ½ mile south of Williams Field Road with a full grade separated traffic interchange.

*North-South Corridor:* The North-South Corridor (US 60 to I-10) is planned to extend 45 miles in the north-south direction along an alignment east of Meridian Road in Pinal County. The concept is to provide a controlled access facility between US 60 in Apache Junction and I-10 near Eloy and Picacho. A current study by ADOT is underway to identify a preferred corridor.

*Intercity Rail:* The Intercity Rail Study is looking at both high speed and commuter rail services between Phoenix and Tucson. Currently there are a number of alternatives being analyzed which will provide the back bone for a transit service along the 'Sun Corridor'. One potential route crosses Meridian Road adjacent to the proposed SR 24 heading east to make use of transit corridors identified in the Superstition Vistas strategic plan.



# APPENDIX A

## 2012 TRAFFIC COUNTS

**Baker**

**Michael Baker Jr., Inc.**  
*Phoenix, Arizona*



Intersection TMC: 1200161  
Count Date: 5/22/2012

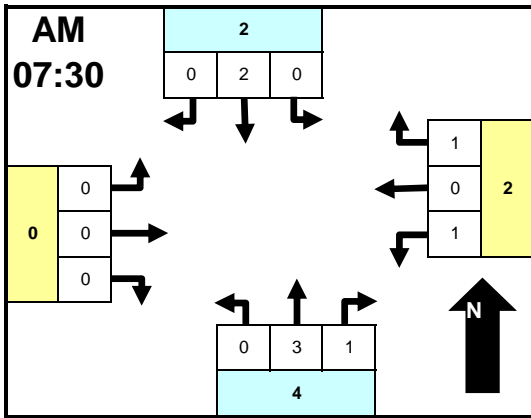

Time	From North DIRT RD DRWY				From East MCDOWELL RD				From South MERIDIAN RD				From West MCDOWELL RD				INTSEC	
	LT	Thru	RT	Ped	LT	Thru	RT	Ped	LT	Thru	RT	Ped	LT	Thru	RT	Ped		
6:00	0	0	0	0	0	0	0	0	0	0	0	0	0	0	0	0	0	0
6:15	0	0	0	0	0	0	0	0	0	0	0	0	0	0	0	0	0	0
6:30	0	0	0	0	0	0	0	0	0	0	0	0	0	0	0	0	0	0
6:45	0	1	0	0	0	0	0	0	0	0	1	0	0	0	0	1	0	3
7:00	0	0	0	0	0	0	0	0	0	0	0	0	0	0	0	0	0	0
7:15	0	0	0	0	0	0	0	0	0	0	0	0	0	0	0	0	0	0
7:30	0	0	0	0	0	0	0	0	0	0	0	0	0	0	0	0	0	0
7:45	0	1	0	0	0	0	0	0	0	0	2	0	0	0	0	0	0	3
8:00	0	0	0	0	0	0	0	0	0	0	0	0	0	0	0	0	0	0
8:15	0	1	0	0	1	0	1	0	0	1	1	0	0	0	0	0	0	5
8:30	0	0	0	0	0	0	0	0	0	0	0	0	0	0	0	0	0	0
8:45	0	0	0	0	0	0	0	0	0	0	0	0	0	0	0	0	0	0
Total	0	3	0	0	1	0	1	0	0	4	1	0	0	0	0	1	0	11
Peak	0	2	0	0	1	0	1	0	0	3	1	0	0	0	0	0	0	8

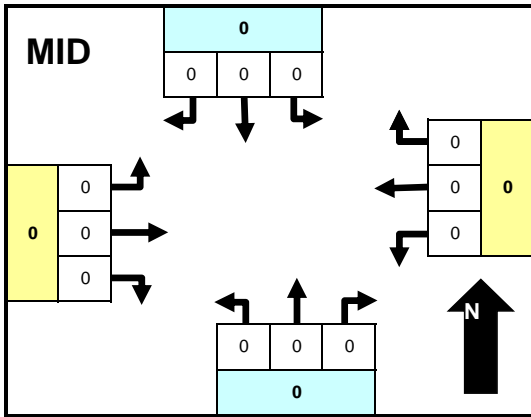

Time	LT	Thru	RT	Ped	LT	Thru	RT	Ped	LT	Thru	RT	Ped	LT	Thru	RT	Ped	TOTAL	
Total	0	0	0	0	0	0	0	0	0	0	0	0	0	0	0	0	0	0
Peak																		0

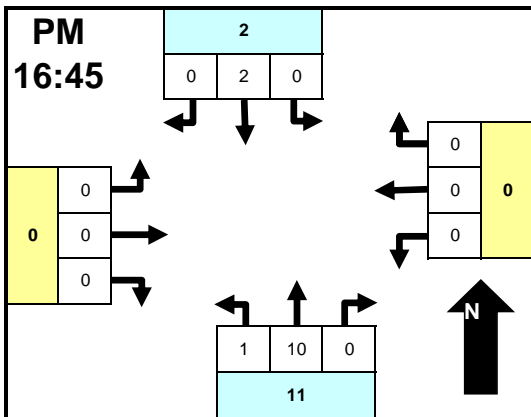

Time	LT	Thru	RT	Ped	LT	Thru	RT	Ped	LT	Thru	RT	Ped	LT	Thru	RT	Ped	TOTAL
15:30	0	0	0	0	0	0	0	0	0	1	0	0	0	0	1	0	2
15:45	0	0	0	0	0	0	0	0	0	1	0	0	0	1	0	0	2
16:00	0	0	0	0	0	0	1	0	0	0	0	0	0	0	0	0	1
16:15	0	0	0	0	0	0	0	0	0	1	0	0	0	0	0	0	1
16:30	0	0	0	0	0	0	0	0	0	1	0	0	0	0	0	0	1
16:45	0	1	0	0	0	0	0	0	0	2	0	0	0	0	0	0	3
17:00	0	1	0	0	0	0	0	0	0	1	0	0	0	0	0	0	2
17:15	0	0	0	0	0	0	0	0	0	1	0	0	0	0	0	0	1
17:30	0	0	0	0	0	0	0	0	1	6	0	0	0	0	0	0	7
17:45	0	0	0	0	1	0	0	0	0	1	1	0	0	0	0	0	3
18:00	0	1	0	0	0	0	0	0	0	0	0	0	0	0	0	0	1
18:15	0	0	0	0	0	0	0	0	0	0	0	0	0	0	0	0	0
Total	0	3	0	0	1	0	1	0	1	15	1	0	0	1	1	0	24
Peak	0	2	0	0	0	0	0	0	1	10	0	0	0	0	0	0	13

**Intersection Statistics**

Per	Peak Hour	Pk Hr Vol	Peak Intvl	Pk Intv Vol
AM	7:30 AM	8	8:15 AM	5
MID				
PM	4:45 PM	13	5:30 PM	7

**Approach Statistics**

Per	Peak Hour	Pk Hr Vol	Peak Hour	Pk Hr Vol	Peak Hour	Pk Hr Vol	Peak Hour	Pk Hr Vol
AM	7:30 AM	2	7:30 AM	2	7:30 AM	4	6:00 AM	1
MID								
PM	4:15 PM	2	3:30 PM	1	4:45 PM	11	3:30 PM	2

**Comments**

**Approach & Departure Volumes (No Peds)**

Per	Approach	Depart	Approach	Depart	Approach	Depart	Approach	Depart
AM	3	5	2	1	5	5	1	0
MID	0	0	0	0	0	0	0	0
PM	3	16	2	2	17	5	2	1



Intersection TMC: 1200162  
Count Date: 5/22/2012

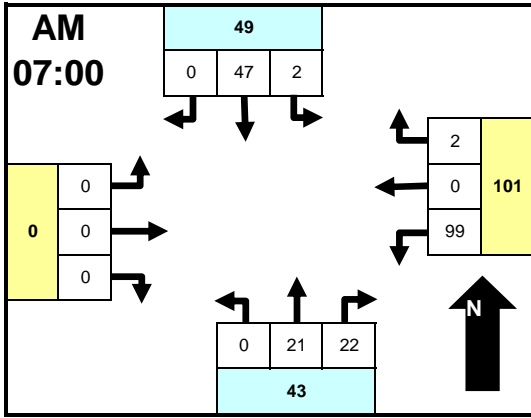

Time	From North MERIDIAN RD				From East MCKELLIPS RD				From South MERIDIAN RD				From West NONE				INTSEC TOTAL	
	LT	Thru	RT	Ped	LT	Thru	RT	Ped	LT	Thru	RT	Ped	LT	Thru	RT	Ped		
6:00	0	9	0	0	11	0	0	0	0	4	1	0	0	0	0	0	0	25
6:15	0	6	0	0	22	0	1	0	0	0	1	0	0	0	0	0	0	30
6:30	1	7	0	0	23	0	1	0	0	3	9	0	0	0	0	0	0	44
6:45	1	14	0	0	21	0	0	0	0	3	2	0	0	0	0	0	0	41
7:00	0	16	0	0	24	0	1	0	0	5	1	0	0	0	0	0	0	47
7:15	0	12	0	0	20	0	1	0	0	3	4	0	0	0	0	0	0	40
7:30	1	15	0	0	34	0	0	0	0	5	7	0	0	0	0	0	0	62
7:45	1	4	0	0	21	0	0	0	0	8	10	0	0	0	0	0	0	44
8:00	0	9	0	0	16	0	1	0	0	1	8	0	0	0	0	0	0	35
8:15	0	8	0	0	11	0	2	0	0	4	3	0	0	0	0	0	0	28
8:30	0	9	0	0	19	0	1	0	0	4	7	0	0	0	0	0	0	40
8:45	0	5	0	0	11	0	0	0	0	4	6	0	0	0	0	0	0	26
<b>Total</b>	<b>4</b>	<b>114</b>	<b>0</b>	<b>0</b>	<b>233</b>	<b>0</b>	<b>8</b>	<b>0</b>	<b>0</b>	<b>44</b>	<b>59</b>	<b>0</b>	<b>0</b>	<b>0</b>	<b>0</b>	<b>0</b>	<b>0</b>	<b>462</b>
<b>Peak</b>	<b>2</b>	<b>47</b>	<b>0</b>	<b>0</b>	<b>99</b>	<b>0</b>	<b>2</b>	<b>0</b>	<b>0</b>	<b>21</b>	<b>22</b>	<b>0</b>	<b>0</b>	<b>0</b>	<b>0</b>	<b>0</b>	<b>0</b>	<b>193</b>

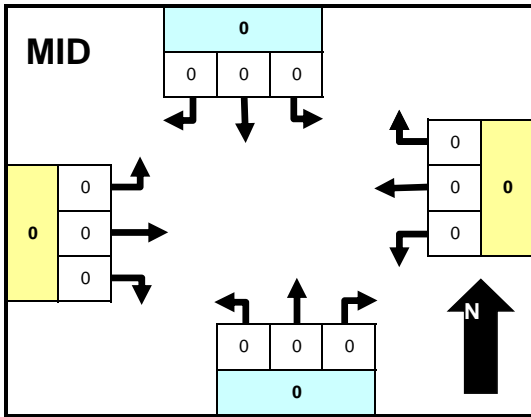

Time	LT	Thru	RT	Ped	LT	Thru	RT	Ped	LT	Thru	RT	Ped	LT	Thru	RT	Ped	TOTAL	
Total	0	0	0	0	0	0	0	0	0	0	0	0	0	0	0	0	0	0
Peak																		0

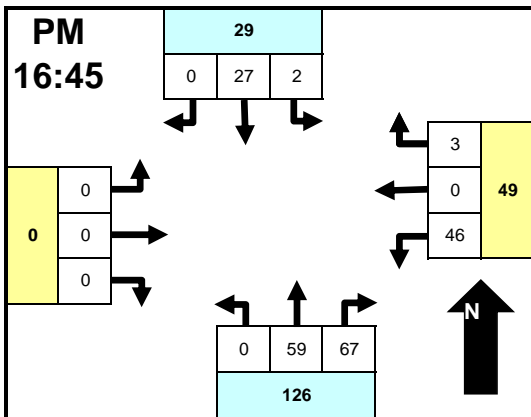

Time	LT	Thru	RT	Ped	LT	Thru	RT	Ped	LT	Thru	RT	Ped	LT	Thru	RT	Ped	TOTAL	
15:30	2	6	0	0	11	0	1	0	0	4	23	0	0	0	0	0	0	47
15:45	0	9	0	0	11	0	2	0	0	8	20	0	0	0	0	0	0	50
16:00	0	8	0	0	16	0	0	0	0	9	26	0	0	0	0	0	0	59
16:15	0	6	0	0	6	0	0	0	0	10	16	0	0	0	0	0	0	38
16:30	0	7	0	0	9	0	2	0	0	12	19	0	0	0	0	0	0	49
16:45	0	8	0	0	11	0	1	0	0	14	10	0	0	0	0	0	0	44
17:00	0	7	0	0	16	0	0	0	0	13	22	0	0	0	0	0	0	58
17:15	0	5	0	0	10	0	1	0	0	11	19	0	0	0	0	0	0	46
17:30	2	7	0	0	9	0	1	0	0	21	16	0	0	0	0	0	0	56
17:45	2	7	0	0	9	0	3	0	0	9	14	0	0	0	0	0	0	44
18:00	4	8	0	0	7	0	7	0	0	5	13	0	0	0	0	0	0	44
18:15	0	4	0	0	9	0	1	0	0	7	19	0	0	0	0	0	0	40
<b>Total</b>	<b>10</b>	<b>82</b>	<b>0</b>	<b>0</b>	<b>124</b>	<b>0</b>	<b>19</b>	<b>0</b>	<b>0</b>	<b>123</b>	<b>217</b>	<b>0</b>	<b>0</b>	<b>0</b>	<b>0</b>	<b>0</b>	<b>0</b>	<b>575</b>
<b>Peak</b>	<b>2</b>	<b>27</b>	<b>0</b>	<b>0</b>	<b>46</b>	<b>0</b>	<b>3</b>	<b>0</b>	<b>0</b>	<b>59</b>	<b>67</b>	<b>0</b>	<b>0</b>	<b>0</b>	<b>0</b>	<b>0</b>	<b>0</b>	<b>204</b>

**Intersection Statistics**

Per	Peak Hour	Pk Hr Vol	Peak Intvl	Pk Intv Vol
AM	7:00 AM	193	7:30 AM	62
MID				
PM	4:45 PM	204	4:00 PM	59

**Approach Statistics**

Per	Peak Hour	Pk Hr Vol	Peak Hour	Pk Hr Vol	Peak Hour	Pk Hr Vol	Peak Hour	Pk Hr Vol
AM	6:45 AM	59	6:45 AM	101	7:15 AM	46		
MID								
PM	5:15 PM	35	4:30 PM	50	4:45 PM	126		

**Comments**

**Approach & Departure Volumes (No Peds)**

Per	Approach	Depart	Approach	Depart	Approach	Depart	Approach	Depart
AM	118	52	241	63	103	347	0	0
MID	0	0	0	0	0	0	0	0
PM	92	142	143	227	340	206	0	0



Intersection TMC: 1200163  
Count Date: 5/22/2012

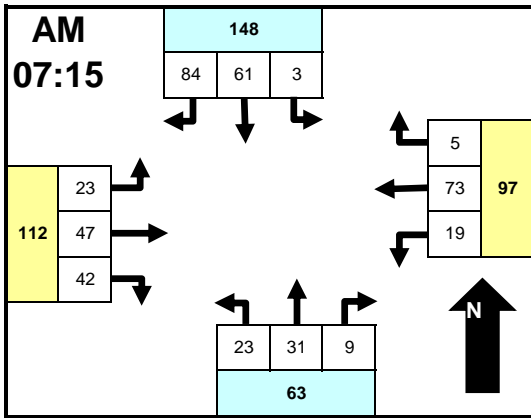

Time	From North MERIDIAN RD				From East LOST DUTCHMAN BLVD				From South MERIDIAN RD				From West BROWN RD				INTSEC	TOTAL
	LT	Thru	RT	Ped	LT	Thru	RT	Ped	LT	Thru	RT	Ped	LT	Thru	RT	Ped		
6:00	0	8	1	0	2	21	0	0	9	4	4	0	2	4	2	0	57	
6:15	0	10	18	0	0	19	1	0	5	1	2	0	1	10	2	0	69	
6:30	0	5	22	0	1	24	3	0	4	7	3	0	7	8	4	0	88	
6:45	2	11	23	0	3	14	1	0	6	5	1	0	3	6	11	0	86	
7:00	0	14	27	0	2	15	2	0	2	5	1	0	3	7	11	0	89	
7:15	0	17	20	0	10	23	3	0	3	4	2	0	4	9	6	0	101	
7:30	1	19	32	0	3	23	1	0	14	9	4	0	4	8	15	0	133	
7:45	1	15	14	0	2	14	1	0	5	9	1	0	11	10	7	0	90	
8:00	1	10	18	0	4	13	0	0	1	9	2	0	4	20	14	0	96	
8:15	0	12	12	0	5	10	0	0	2	5	2	0	1	16	9	0	74	
8:30	1	8	15	0	1	19	1	0	4	9	0	0	3	11	7	0	79	
8:45	3	7	10	0	4	20	1	0	4	6	5	0	2	17	10	0	89	
<b>Total</b>	<b>9</b>	<b>136</b>	<b>212</b>	<b>0</b>	<b>37</b>	<b>215</b>	<b>14</b>	<b>0</b>	<b>59</b>	<b>73</b>	<b>27</b>	<b>0</b>	<b>45</b>	<b>126</b>	<b>98</b>	<b>0</b>	<b>1051</b>	
<b>Peak</b>	<b>3</b>	<b>61</b>	<b>84</b>	<b>0</b>	<b>19</b>	<b>73</b>	<b>5</b>	<b>0</b>	<b>23</b>	<b>31</b>	<b>9</b>	<b>0</b>	<b>23</b>	<b>47</b>	<b>42</b>	<b>0</b>	<b>420</b>	

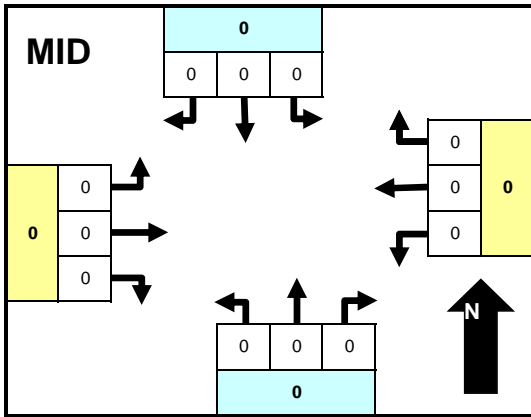

Time	LT	Thru	RT	Ped	LT	Thru	RT	Ped	LT	Thru	RT	Ped	LT	Thru	RT	Ped	TOTAL
<b>Total</b>	<b>0</b>	<b>0</b>	<b>0</b>	<b>0</b>	<b>0</b>	<b>0</b>	<b>0</b>	<b>0</b>	<b>0</b>	<b>0</b>	<b>0</b>	<b>0</b>	<b>0</b>	<b>0</b>	<b>0</b>	<b>0</b>	<b>0</b>
<b>Peak</b>																	<b>0</b>

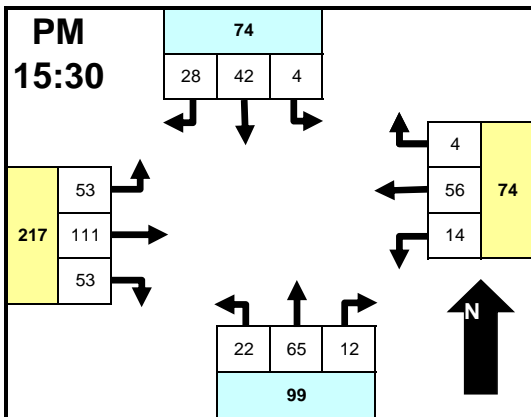

Time	LT	Thru	RT	Ped	LT	Thru	RT	Ped	LT	Thru	RT	Ped	LT	Thru	RT	Ped	TOTAL
15:30	4	8	9	0	5	21	0	0	1	20	5	0	12	23	16	0	124
15:45	0	11	8	0	3	16	1	0	9	18	3	0	11	32	8	0	120
16:00	0	14	9	0	4	13	2	0	6	11	2	0	17	26	19	0	123
16:15	0	9	2	0	2	6	1	0	6	16	2	0	13	30	10	0	97
16:30	0	12	7	0	2	11	0	0	5	18	3	0	12	37	8	0	115
16:45	0	10	4	0	2	13	1	0	2	15	3	0	15	27	7	0	99
17:00	0	11	9	0	1	15	0	0	5	11	1	0	21	29	11	0	114
17:15	1	8	8	0	2	15	1	0	7	20	1	0	11	22	15	0	111
17:30	0	11	9	0	3	10	2	0	4	18	0	0	26	32	4	0	119
17:45	1	7	5	0	0	10	0	0	4	8	2	0	15	22	3	0	77
18:00	1	11	6	0	4	9	2	0	9	8	1	0	25	34	7	0	117
18:15	0	8	3	0	2	12	2	0	3	17	2	0	15	24	5	0	93
<b>Total</b>	<b>7</b>	<b>120</b>	<b>79</b>	<b>0</b>	<b>30</b>	<b>151</b>	<b>12</b>	<b>0</b>	<b>61</b>	<b>180</b>	<b>25</b>	<b>0</b>	<b>193</b>	<b>338</b>	<b>113</b>	<b>0</b>	<b>1309</b>
<b>Peak</b>	<b>4</b>	<b>42</b>	<b>28</b>	<b>0</b>	<b>14</b>	<b>56</b>	<b>4</b>	<b>0</b>	<b>22</b>	<b>65</b>	<b>12</b>	<b>0</b>	<b>53</b>	<b>111</b>	<b>53</b>	<b>0</b>	<b>464</b>

Intersection Statistics

Per	Peak Hour	Pk Hr Vol	Peak Intvl	Pk Intv Vol
AM	7:15 AM	420	7:30 AM	133
MID				
PM	3:30 PM	464	3:30 PM	124

Approach Statistics

Per	Peak Hour	Pk Hr Vol	Peak Hour	Pk Hr Vol	Peak Hour	Pk Hr Vol	Peak Hour	Pk Hr Vol
AM	6:45 AM	166	6:30 AM	101	7:15 AM	63	7:30 AM	119
MID								
PM	3:30 PM	74	3:30 PM	74	3:30 PM	99	3:45 PM	223

Comments

Approach & Departure Volumes (No Peds)

Per	Approach	Depart	Approach	Depart	Approach	Depart	Approach	Depart
AM	357	132	266	162	159	271	269	486
MID	0	0	0	0	0	0	0	0
PM	206	385	193	370	266	263	644	291





Intersection TMC: 1200164  
Count Date: 5/22/2012

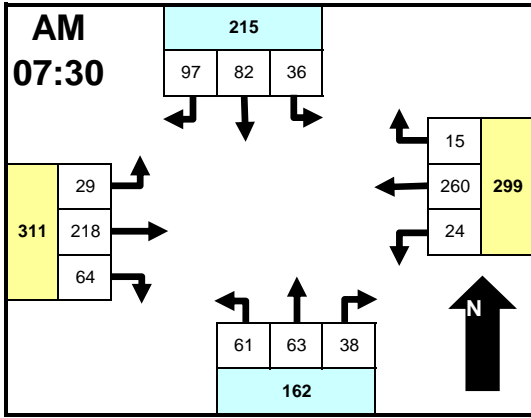

Time	From North MERIDIAN RD				From East SUPERSTITION BLVD				From South MERIDIAN RD				From West UNIVERSITY DR				INTSEC	TOTAL
	LT	Thru	RT	Ped	LT	Thru	RT	Ped	LT	Thru	RT	Ped	LT	Thru	RT	Ped		
6:00	3	7	16	0	0	52	2	0	6	7	2	0	3	16	4	0	118	
6:15	6	10	14	0	3	47	1	0	12	4	4	0	3	19	5	0	128	
6:30	5	10	11	0	5	46	1	0	7	9	3	0	6	28	8	0	139	
6:45	11	9	16	0	3	62	2	0	11	10	1	0	3	49	7	0	184	
7:00	8	17	21	0	2	68	4	0	17	9	6	0	5	36	12	0	205	
7:15	12	19	27	0	12	65	3	0	15	8	5	0	5	44	11	0	226	
7:30	11	30	33	0	6	75	4	0	11	14	9	0	10	59	14	0	276	
7:45	4	22	25	0	6	68	2	0	10	15	9	0	6	53	14	0	234	
8:00	10	14	20	0	6	59	3	0	23	18	10	0	8	49	19	0	239	
8:15	11	16	19	0	6	58	6	0	17	16	10	0	5	57	17	0	238	
8:30	3	20	14	0	7	47	3	0	16	19	10	0	9	64	17	0	229	
8:45	3	19	12	0	8	71	3	0	17	16	15	0	3	51	12	0	230	
<b>Total</b>	<b>87</b>	<b>193</b>	<b>228</b>	<b>0</b>	<b>64</b>	<b>718</b>	<b>34</b>	<b>0</b>	<b>162</b>	<b>145</b>	<b>84</b>	<b>0</b>	<b>66</b>	<b>525</b>	<b>140</b>	<b>0</b>	<b>2446</b>	
<b>Peak</b>	<b>36</b>	<b>82</b>	<b>97</b>	<b>0</b>	<b>24</b>	<b>260</b>	<b>15</b>	<b>0</b>	<b>61</b>	<b>63</b>	<b>38</b>	<b>0</b>	<b>29</b>	<b>218</b>	<b>64</b>	<b>0</b>	<b>987</b>	

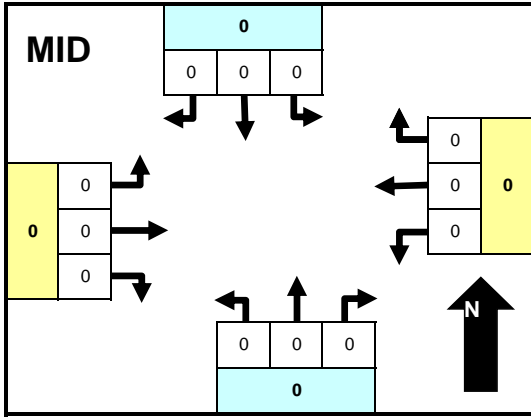

Time	LT	Thru	RT	Ped	LT	Thru	RT	Ped	LT	Thru	RT	Ped	LT	Thru	RT	Ped	TOTAL	
<b>Total</b>	<b>0</b>	<b>0</b>	<b>0</b>	<b>0</b>	<b>0</b>	<b>0</b>	<b>0</b>	<b>0</b>	<b>0</b>	<b>0</b>	<b>0</b>	<b>0</b>	<b>0</b>	<b>0</b>	<b>0</b>	<b>0</b>	<b>0</b>	<b>0</b>
<b>Peak</b>																		<b>0</b>

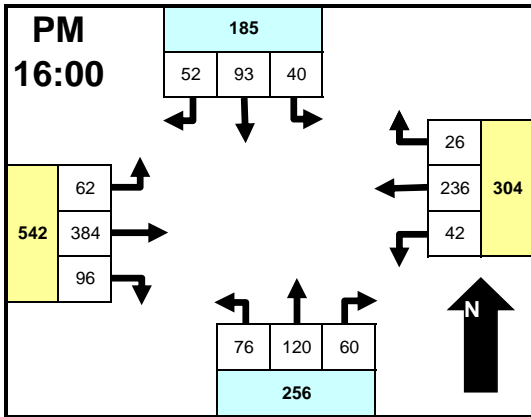

Time	LT	Thru	RT	Ped	LT	Thru	RT	Ped	LT	Thru	RT	Ped	LT	Thru	RT	Ped	TOTAL
15:30	10	22	16	0	15	57	4	0	15	28	20	0	16	93	12	0	308
15:45	13	26	12	0	10	44	3	0	15	33	18	0	22	88	19	0	303
16:00	15	23	12	0	9	58	9	0	20	20	15	0	14	88	27	0	310
16:15	9	24	15	0	15	68	4	0	24	32	15	0	15	108	20	0	349
16:30	7	25	12	0	10	50	6	0	18	36	15	0	22	90	22	0	313
16:45	9	21	13	0	8	60	7	0	14	32	15	0	11	98	27	0	315
17:00	11	21	10	0	8	60	7	0	14	30	13	0	17	87	17	0	295
17:15	17	20	16	0	4	47	9	0	15	33	6	0	22	91	15	0	295
17:30	8	14	8	0	4	49	5	0	24	24	7	0	20	77	20	0	260
17:45	4	13	7	0	0	47	5	0	14	16	15	0	16	75	16	0	228
18:00	8	12	9	0	7	36	6	0	15	24	10	0	13	62	20	0	222
18:15	7	16	6	0	6	48	4	0	8	20	7	0	16	61	14	0	213
<b>Total</b>	<b>118</b>	<b>237</b>	<b>136</b>	<b>0</b>	<b>96</b>	<b>624</b>	<b>69</b>	<b>0</b>	<b>196</b>	<b>328</b>	<b>156</b>	<b>0</b>	<b>204</b>	<b>1018</b>	<b>229</b>	<b>0</b>	<b>3411</b>
<b>Peak</b>	<b>40</b>	<b>93</b>	<b>52</b>	<b>0</b>	<b>42</b>	<b>236</b>	<b>26</b>	<b>0</b>	<b>76</b>	<b>120</b>	<b>60</b>	<b>0</b>	<b>62</b>	<b>384</b>	<b>96</b>	<b>0</b>	<b>1287</b>

Intersection Statistics

Per	Peak Hour	Pk Hr Vol	Peak Intvl	Pk Intv Vol
AM	7:30 AM	987	7:30 AM	276
MID				
PM	4:00 PM	1287	4:15 PM	349

Approach Statistics

Per	Peak Hour	Pk Hr Vol	Peak Hour	Pk Hr Vol	Peak Hour	Pk Hr Vol	Peak Hour	Pk Hr Vol
AM	7:00 AM	229	7:00 AM	315	8:00 AM	187	7:45 AM	318
MID								
PM	3:30 PM	197	4:00 PM	304	3:45 PM	261	4:00 PM	542

Comments

Approach & Departure Volumes (No Peds)

Per	Approach	Depart	Approach	Depart	Approach	Depart	Approach	Depart
AM	508	245	816	696	391	397	731	1108
MID	0	0	0	0	0	0	0	0
PM	491	601	789	1292	680	562	1451	956



Intersection TMC: 1200165  
Count Date: 5/22/2012

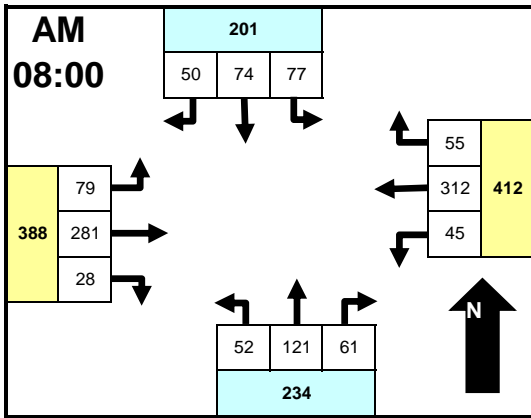

Time	From North MERIDIAN RD				From East APACHE TRAIL				From South MERIDIAN RD				From West APACHE TRAIL				INTSEC	TOTAL
	LT	Thru	RT	Ped	LT	Thru	RT	Ped	LT	Thru	RT	Ped	LT	Thru	RT	Ped		
6:00	5	7	2	0	1	34	5	0	2	9	6	0	0	13	2	0	86	
6:15	5	13	8	0	0	25	4	0	4	9	6	0	9	14	6	0	103	
6:30	6	20	9	0	4	37	8	0	3	10	3	0	5	27	2	0	134	
6:45	11	12	6	0	3	53	12	0	3	17	4	0	5	30	4	0	160	
7:00	15	26	11	0	5	36	11	0	9	14	4	0	5	40	2	0	178	
7:15	12	31	8	0	9	62	17	0	8	15	11	0	12	44	6	0	235	
7:30	16	28	15	0	8	71	12	0	9	16	5	0	21	52	4	0	257	
7:45	28	21	7	0	8	62	13	0	13	20	8	0	16	61	6	0	263	
8:00	14	18	10	0	9	68	16	0	10	30	17	0	18	67	7	0	284	
8:15	19	22	11	0	12	75	16	0	15	31	18	0	20	63	4	0	306	
8:30	23	24	17	0	8	91	13	0	16	33	18	0	21	75	6	0	345	
8:45	21	10	12	0	16	78	10	0	11	27	8	0	20	76	11	0	300	
<b>Total</b>	<b>175</b>	<b>232</b>	<b>116</b>	<b>0</b>	<b>83</b>	<b>692</b>	<b>137</b>	<b>0</b>	<b>103</b>	<b>231</b>	<b>108</b>	<b>0</b>	<b>152</b>	<b>562</b>	<b>60</b>	<b>0</b>	<b>2651</b>	
<b>Peak</b>	<b>77</b>	<b>74</b>	<b>50</b>	<b>0</b>	<b>45</b>	<b>312</b>	<b>55</b>	<b>0</b>	<b>52</b>	<b>121</b>	<b>61</b>	<b>0</b>	<b>79</b>	<b>281</b>	<b>28</b>	<b>0</b>	<b>1235</b>	

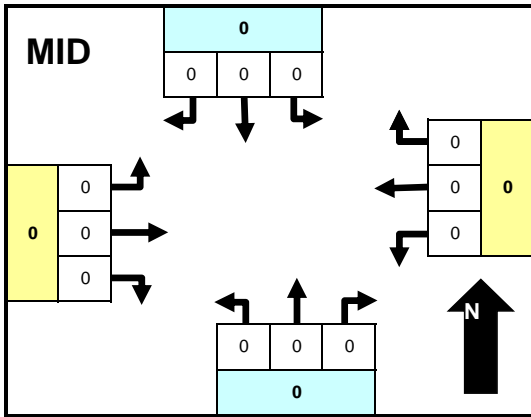

Time	LT	Thru	RT	Ped	LT	Thru	RT	Ped	LT	Thru	RT	Ped	LT	Thru	RT	Ped	TOTAL	
<b>Total</b>	<b>0</b>	<b>0</b>	<b>0</b>	<b>0</b>	<b>0</b>	<b>0</b>	<b>0</b>	<b>0</b>	<b>0</b>	<b>0</b>	<b>0</b>	<b>0</b>	<b>0</b>	<b>0</b>	<b>0</b>	<b>0</b>	<b>0</b>	<b>0</b>
<b>Peak</b>																		<b>0</b>

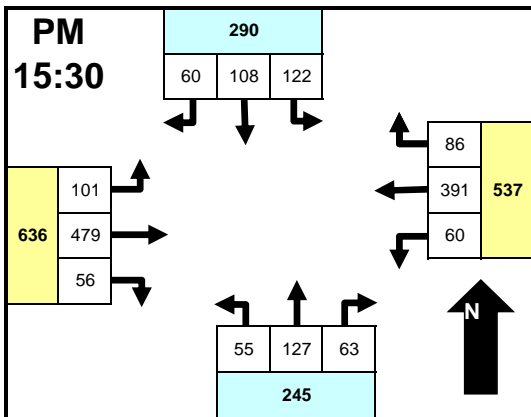

Time	LT	Thru	RT	Ped	LT	Thru	RT	Ped	LT	Thru	RT	Ped	LT	Thru	RT	Ped	TOTAL
15:30	27	23	14	0	17	104	20	0	18	24	12	0	32	118	14	0	423
15:45	30	23	23	0	13	101	21	0	11	37	19	0	19	123	12	0	432
16:00	36	32	10	0	12	82	22	0	14	26	18	0	22	106	12	0	392
16:15	29	30	13	0	18	104	23	0	12	40	14	0	28	132	18	0	461
16:30	22	24	12	0	14	77	27	0	18	32	14	0	41	93	9	0	383
16:45	34	31	14	0	15	88	23	0	17	22	14	0	28	120	7	0	413
17:00	34	25	15	0	15	82	20	0	7	24	13	0	27	96	10	0	368
17:15	22	30	11	0	19	76	13	0	11	33	20	0	15	111	10	0	371
17:30	22	23	7	0	11	72	25	0	9	23	17	0	17	120	10	0	356
17:45	20	30	8	0	20	72	19	0	9	25	6	0	22	76	14	0	321
18:00	12	24	7	0	20	64	24	0	7	20	10	0	22	88	5	0	303
18:15	22	22	7	0	14	59	16	0	15	19	16	0	14	75	8	0	287
<b>Total</b>	<b>310</b>	<b>317</b>	<b>141</b>	<b>0</b>	<b>188</b>	<b>981</b>	<b>253</b>	<b>0</b>	<b>148</b>	<b>325</b>	<b>173</b>	<b>0</b>	<b>287</b>	<b>1258</b>	<b>129</b>	<b>0</b>	<b>4510</b>
<b>Peak</b>	<b>122</b>	<b>108</b>	<b>60</b>	<b>0</b>	<b>60</b>	<b>391</b>	<b>86</b>	<b>0</b>	<b>55</b>	<b>127</b>	<b>63</b>	<b>0</b>	<b>101</b>	<b>479</b>	<b>56</b>	<b>0</b>	<b>1708</b>

**Intersection Statistics**

Per	Peak Hour	Pk Hr Vol	Peak Intvl	Pk Intv Vol
AM	8:00 AM	1235	8:30 AM	345
MID				
PM	3:30 PM	1708	4:15 PM	461

**Approach Statistics**

Per	Peak Hour	Pk Hr Vol	Peak Hour	Pk Hr Vol	Peak Hour	Pk Hr Vol	Peak Hour	Pk Hr Vol
AM	7:00 AM	218	8:00 AM	412	8:00 AM	234	8:00 AM	388
MID								
PM	3:30 PM	290	3:30 PM	537	3:45 PM	255	3:30 PM	636

**Comments**

**Approach & Departure Volumes (No Peds)**

Per	Approach	Depart	Approach	Depart	Approach	Depart	Approach	Depart
AM	523	520	912	845	442	375	774	911
MID	0	0	0	0	0	0	0	0
PM	768	865	1422	1741	646	634	1674	1270



Intersection TMC: 1200166  
Count Date: 5/22/2012

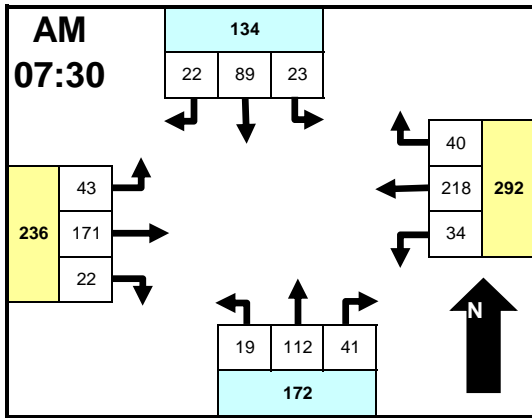

Time	From North MERIDIAN RD				From East BROADWAY RD				From South MERIDIAN RD				From West BROADWAY RD				INTSEC	TOTAL
	LT	Thru	RT	Ped	LT	Thru	RT	Ped	LT	Thru	RT	Ped	LT	Thru	RT	Ped		
6:00	1	7	1	0	3	39	1	0	1	7	4	0	5	17	1	0	87	
6:15	2	14	4	0	1	40	2	0	2	10	2	0	5	11	1	0	94	
6:30	5	11	3	0	3	46	2	0	3	11	6	0	1	23	6	0	120	
6:45	2	12	2	0	7	54	5	0	3	12	2	0	6	34	3	0	142	
7:00	4	18	7	0	6	51	7	0	2	14	3	0	4	32	5	0	153	
7:15	10	31	4	0	10	56	6	0	5	22	6	0	2	38	4	0	194	
7:30	5	27	5	0	8	61	7	0	6	31	10	0	5	35	6	0	206	
7:45	7	19	5	0	7	58	13	0	3	30	9	0	9	50	3	0	213	
8:00	6	19	6	0	10	61	13	0	3	22	9	0	14	48	5	0	216	
8:15	5	24	6	0	9	38	7	0	7	29	13	0	15	38	8	0	199	
8:30	7	18	7	0	6	39	3	0	6	39	13	0	13	41	4	0	196	
8:45	8	22	7	0	8	39	12	0	7	27	6	0	16	40	5	0	197	
<b>Total</b>	<b>62</b>	<b>222</b>	<b>57</b>	<b>0</b>	<b>78</b>	<b>582</b>	<b>78</b>	<b>0</b>	<b>48</b>	<b>254</b>	<b>83</b>	<b>0</b>	<b>95</b>	<b>407</b>	<b>51</b>	<b>0</b>	<b>2017</b>	
<b>Peak</b>	<b>23</b>	<b>89</b>	<b>22</b>	<b>0</b>	<b>34</b>	<b>218</b>	<b>40</b>	<b>0</b>	<b>19</b>	<b>112</b>	<b>41</b>	<b>0</b>	<b>43</b>	<b>171</b>	<b>22</b>	<b>0</b>	<b>834</b>	

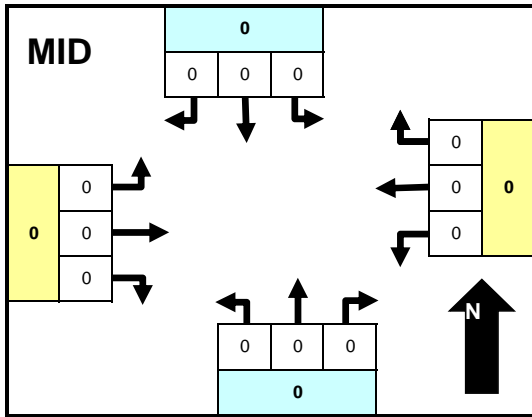

Time	LT	Thru	RT	Ped	LT	Thru	RT	Ped	LT	Thru	RT	Ped	LT	Thru	RT	Ped	TOTAL
<b>Total</b>	<b>0</b>	<b>0</b>	<b>0</b>	<b>0</b>	<b>0</b>	<b>0</b>	<b>0</b>	<b>0</b>	<b>0</b>	<b>0</b>	<b>0</b>	<b>0</b>	<b>0</b>	<b>0</b>	<b>0</b>	<b>0</b>	<b>0</b>
<b>Peak</b>																	<b>0</b>

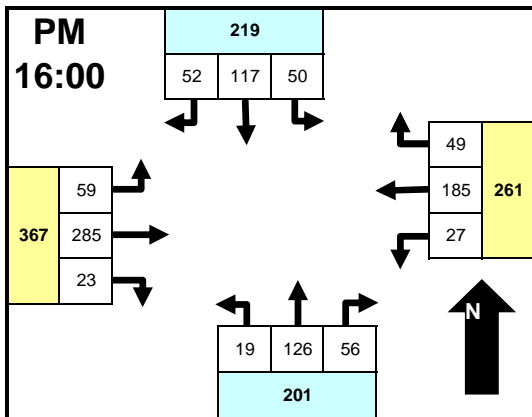

Time	LT	Thru	RT	Ped	LT	Thru	RT	Ped	LT	Thru	RT	Ped	LT	Thru	RT	Ped	TOTAL
15:30	14	30	8	0	4	54	9	0	3	19	19	0	12	73	4	0	249
15:45	14	28	10	0	10	43	11	0	4	26	20	0	20	56	4	0	246
16:00	16	24	15	0	6	42	12	0	2	34	9	0	18	66	9	0	253
16:15	12	35	17	0	8	45	16	0	7	26	16	0	10	74	8	0	274
16:30	7	30	13	0	5	46	7	0	5	31	14	0	13	77	3	0	251
16:45	15	28	7	0	8	52	14	0	5	35	17	0	18	68	3	0	270
17:00	11	36	12	0	10	33	11	0	1	24	9	0	11	63	9	0	230
17:15	14	32	6	0	5	55	11	0	3	24	2	0	12	75	5	0	244
17:30	11	33	9	0	6	49	9	0	1	25	4	0	10	62	3	0	222
17:45	10	22	16	0	7	32	4	0	4	14	11	0	10	56	3	0	189
18:00	6	31	8	0	10	52	7	0	3	22	16	0	6	60	3	0	224
18:15	9	15	9	0	5	30	10	0	4	18	13	0	11	48	1	0	173
<b>Total</b>	<b>139</b>	<b>344</b>	<b>130</b>	<b>0</b>	<b>84</b>	<b>533</b>	<b>121</b>	<b>0</b>	<b>42</b>	<b>298</b>	<b>150</b>	<b>0</b>	<b>151</b>	<b>778</b>	<b>55</b>	<b>0</b>	<b>2825</b>
<b>Peak</b>	<b>50</b>	<b>117</b>	<b>52</b>	<b>0</b>	<b>27</b>	<b>185</b>	<b>49</b>	<b>0</b>	<b>19</b>	<b>126</b>	<b>56</b>	<b>0</b>	<b>59</b>	<b>285</b>	<b>23</b>	<b>0</b>	<b>1048</b>

**Intersection Statistics**

Per	Peak Hour	Pk Hr Vol	Peak Intvl	Pk Intv Vol
AM	7:30 AM	834	8:00 AM	216
MID				
PM	4:00 PM	1048	4:15 PM	274

**Approach Statistics**

Per	Peak Hour	Pk Hr Vol	Peak Hour	Pk Hr Vol	Peak Hour	Pk Hr Vol	Peak Hour	Pk Hr Vol
AM	7:15 AM	144	7:15 AM	310	7:45 AM	183	7:45 AM	248
MID								
PM	3:30 PM	223	4:45 PM	263	4:00 PM	201	4:00 PM	367

**Comments**

**Approach & Departure Volumes (No Peds)**

Per	Approach	Depart	Approach	Depart	Approach	Depart	Approach	Depart
AM	341	427	738	552	385	351	553	687
MID	0	0	0	0	0	0	0	0
PM	613	570	738	1067	490	483	984	705



Intersection TMC: 1200167  
Count Date: 5/22/2012

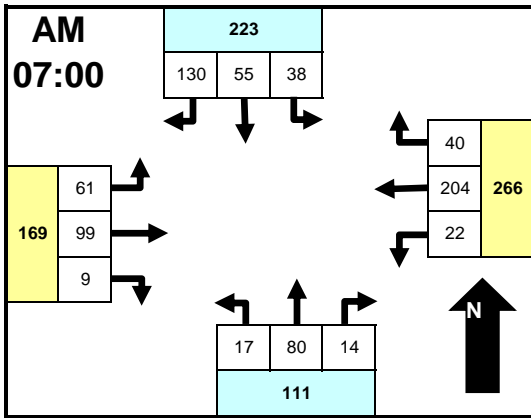

Time	From North MERIDIAN RD				From East SOUTHERN AVE				From South MERIDIAN RD				From West SOUTHERN AVE				INTSEC	TOTAL
	LT	Thru	RT	Ped	LT	Thru	RT	Ped	LT	Thru	RT	Ped	LT	Thru	RT	Ped		
6:00	2	8	9	0	3	29	5	0	0	3	4	0	5	10	1	0	79	
6:15	6	9	12	0	3	22	3	0	1	8	1	0	5	9	0	0	79	
6:30	5	15	17	0	5	32	4	0	3	5	4	0	8	14	0	0	112	
6:45	9	9	11	0	3	30	3	0	8	17	4	0	12	29	6	0	141	
7:00	10	10	27	0	5	55	9	0	3	14	3	0	17	21	2	0	176	
7:15	10	13	41	0	5	52	14	0	6	19	3	0	17	17	4	0	201	
7:30	7	24	40	0	5	53	11	0	2	19	5	0	16	34	2	0	218	
7:45	11	8	22	0	7	44	6	0	6	28	3	0	11	27	1	0	174	
8:00	2	10	20	0	6	33	9	0	3	15	6	0	10	18	2	0	134	
8:15	5	11	19	0	5	23	15	0	3	18	3	0	12	21	6	0	141	
8:30	6	6	19	0	2	42	19	0	0	29	6	0	14	18	6	0	167	
8:45	7	10	17	0	4	28	2	0	4	10	5	0	19	12	0	0	118	
<b>Total</b>	<b>80</b>	<b>133</b>	<b>254</b>	<b>0</b>	<b>53</b>	<b>443</b>	<b>100</b>	<b>0</b>	<b>39</b>	<b>185</b>	<b>47</b>	<b>0</b>	<b>146</b>	<b>230</b>	<b>30</b>	<b>0</b>	<b>1740</b>	
<b>Peak</b>	<b>38</b>	<b>55</b>	<b>130</b>	<b>0</b>	<b>22</b>	<b>204</b>	<b>40</b>	<b>0</b>	<b>17</b>	<b>80</b>	<b>14</b>	<b>0</b>	<b>61</b>	<b>99</b>	<b>9</b>	<b>0</b>	<b>769</b>	

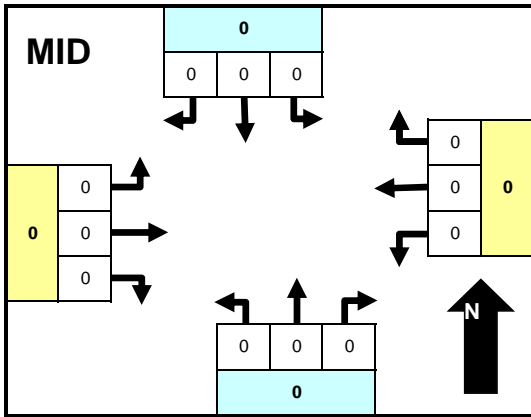

Time	LT	Thru	RT	Ped	LT	Thru	RT	Ped	LT	Thru	RT	Ped	LT	Thru	RT	Ped	TOTAL	
<b>Total</b>	<b>0</b>	<b>0</b>	<b>0</b>	<b>0</b>	<b>0</b>	<b>0</b>	<b>0</b>	<b>0</b>	<b>0</b>	<b>0</b>	<b>0</b>	<b>0</b>	<b>0</b>	<b>0</b>	<b>0</b>	<b>0</b>	<b>0</b>	<b>0</b>
<b>Peak</b>																		<b>0</b>

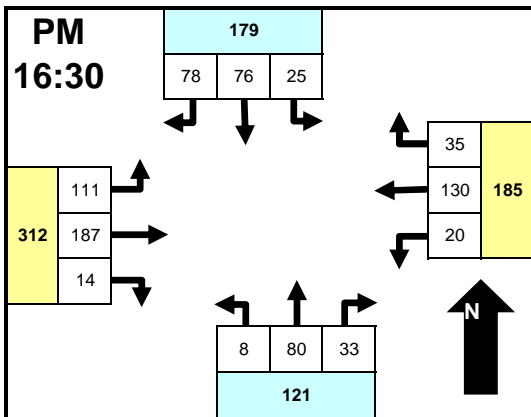

Time	LT	Thru	RT	Ped	LT	Thru	RT	Ped	LT	Thru	RT	Ped	LT	Thru	RT	Ped	TOTAL
15:30	9	14	21	0	2	20	9	0	3	15	5	0	24	44	1	0	167
15:45	8	12	18	0	2	26	9	0	2	22	8	0	31	47	2	0	187
16:00	4	16	20	0	3	39	7	0	4	32	4	0	25	49	3	0	206
16:15	2	17	17	0	4	26	11	0	1	11	6	0	30	46	8	0	179
16:30	9	14	25	0	6	27	5	0	3	25	6	0	25	49	6	0	200
16:45	5	16	17	0	6	34	17	0	1	24	6	0	30	46	4	0	206
17:00	6	17	19	0	6	35	9	0	2	15	6	0	27	47	2	0	191
17:15	5	29	17	0	2	34	4	0	2	16	15	0	29	45	2	0	200
17:30	6	18	17	0	1	28	7	0	5	9	2	0	21	33	3	0	150
17:45	4	12	13	0	0	33	3	0	1	20	4	0	24	46	3	0	163
18:00	3	15	11	0	3	23	7	0	1	13	2	0	24	33	0	0	135
18:15	5	16	12	0	4	19	11	0	3	7	5	0	28	27	2	0	139
<b>Total</b>	<b>66</b>	<b>196</b>	<b>207</b>	<b>0</b>	<b>39</b>	<b>344</b>	<b>99</b>	<b>0</b>	<b>28</b>	<b>209</b>	<b>69</b>	<b>0</b>	<b>318</b>	<b>512</b>	<b>36</b>	<b>0</b>	<b>2123</b>
<b>Peak</b>	<b>25</b>	<b>76</b>	<b>78</b>	<b>0</b>	<b>20</b>	<b>130</b>	<b>35</b>	<b>0</b>	<b>8</b>	<b>80</b>	<b>33</b>	<b>0</b>	<b>111</b>	<b>187</b>	<b>14</b>	<b>0</b>	<b>797</b>

**Intersection Statistics**

Per	Peak Hour	Pk Hr Vol	Peak Intvl	Pk Intv Vol
AM	7:00 AM	769	7:30 AM	218
MID				
PM	4:30 PM	797	4:00 PM	206

**Approach Statistics**

Per	Peak Hour	Pk Hr Vol	Peak Hour	Pk Hr Vol	Peak Hour	Pk Hr Vol	Peak Hour	Pk Hr Vol
AM	7:00 AM	223	7:00 AM	266	7:45 AM	120	6:45 AM	177
MID								
PM	4:30 PM	179	4:15 PM	186	3:45 PM	124	3:45 PM	321

**Comments**

**Approach & Departure Volumes (No Peds)**

Per	Approach	Depart	Approach	Depart	Approach	Depart	Approach	Depart
AM	467	431	596	357	271	216	406	736
MID	0	0	0	0	0	0	0	0
PM	469	626	482	647	306	271	866	579





Intersection TMC: 1200168  
Count Date: 5/22/2012

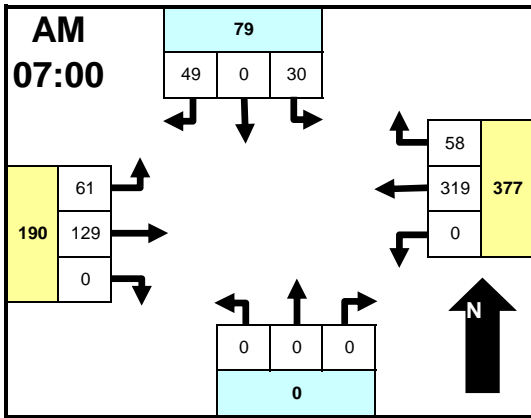

Time	From North MERIDIAN RD				From East BASELINE RD				From South NONE				From West BASELINE RD				INTSEC TOTAL	
	LT	Thru	RT	Ped	LT	Thru	RT	Ped	LT	Thru	RT	Ped	LT	Thru	RT	Ped		
6:00	7	0	5	0	0	39	4	0	0	0	0	0	0	4	14	0	0	73
6:15	5	0	7	0	0	68	7	0	0	0	0	0	0	5	13	0	0	105
6:30	13	0	4	0	0	75	8	0	0	0	0	0	0	5	21	0	0	126
6:45	9	0	10	0	0	72	21	0	0	0	0	0	0	11	24	0	0	147
7:00	4	0	9	0	0	93	8	0	0	0	0	0	0	11	33	0	0	158
7:15	7	0	11	0	0	93	13	0	0	0	0	0	0	15	30	0	0	169
7:30	11	0	20	0	0	71	12	0	0	0	0	0	0	16	34	0	0	164
7:45	8	0	9	0	0	62	25	0	0	0	0	0	0	19	32	0	0	155
8:00	3	0	11	0	0	54	11	0	0	0	0	0	0	15	34	0	0	128
8:15	6	0	13	0	0	53	12	0	0	0	0	0	0	13	29	0	0	126
8:30	8	0	7	0	0	51	16	0	0	0	0	0	0	14	23	0	0	119
8:45	6	0	7	0	0	32	6	0	0	0	0	0	0	11	27	0	0	89
<b>Total</b>	<b>87</b>	<b>0</b>	<b>113</b>	<b>0</b>	<b>0</b>	<b>763</b>	<b>143</b>	<b>0</b>	<b>0</b>	<b>0</b>	<b>0</b>	<b>0</b>	<b>139</b>	<b>314</b>	<b>0</b>	<b>0</b>	<b>1559</b>	
<b>Peak</b>	<b>30</b>	<b>0</b>	<b>49</b>	<b>0</b>	<b>0</b>	<b>319</b>	<b>58</b>	<b>0</b>	<b>0</b>	<b>0</b>	<b>0</b>	<b>0</b>	<b>61</b>	<b>129</b>	<b>0</b>	<b>0</b>	<b>646</b>	

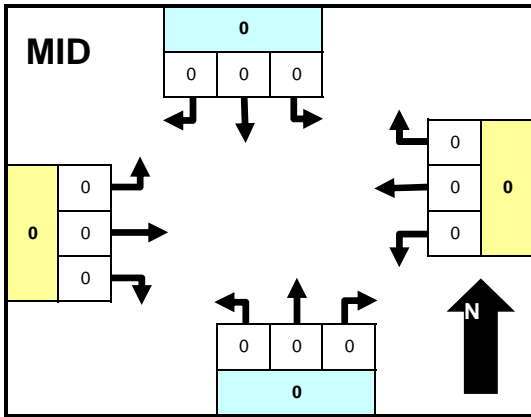

Time	LT	Thru	RT	Ped	LT	Thru	RT	Ped	LT	Thru	RT	Ped	LT	Thru	RT	Ped	TOTAL
Total	0	0	0	0	0	0	0	0	0	0	0	0	0	0	0	0	0
Peak																	0

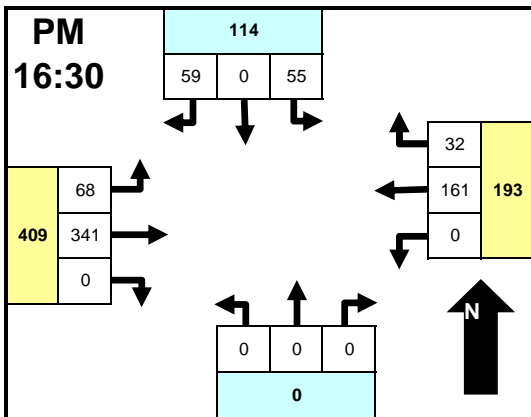

Time	LT	Thru	RT	Ped	LT	Thru	RT	Ped	LT	Thru	RT	Ped	LT	Thru	RT	Ped	TOTAL
15:30	8	0	12	0	0	44	4	0	0	0	0	0	19	56	0	0	143
15:45	6	0	9	0	0	30	8	0	0	0	0	0	22	60	0	0	135
16:00	9	0	13	0	0	44	12	0	0	0	0	0	21	71	0	0	170
16:15	15	0	9	0	0	37	7	0	0	0	0	0	14	69	0	0	151
16:30	16	0	13	0	0	26	10	0	0	0	0	0	19	71	0	0	155
16:45	12	0	13	0	0	53	8	0	0	0	0	0	21	84	0	0	191
17:00	10	0	18	0	0	39	8	0	0	0	0	0	13	83	0	0	171
17:15	17	0	15	0	0	43	6	0	0	0	0	0	15	103	0	0	199
17:30	9	0	14	0	0	31	8	0	0	0	0	0	8	80	0	0	150
17:45	10	0	8	0	0	24	4	0	0	0	0	0	15	66	0	0	127
18:00	6	0	7	0	0	32	4	0	0	0	0	0	10	82	0	0	141
18:15	10	0	13	0	0	20	2	0	0	0	0	0	12	52	0	0	109
<b>Total</b>	<b>128</b>	<b>0</b>	<b>144</b>	<b>0</b>	<b>0</b>	<b>423</b>	<b>81</b>	<b>0</b>	<b>0</b>	<b>0</b>	<b>0</b>	<b>0</b>	<b>189</b>	<b>877</b>	<b>0</b>	<b>0</b>	<b>1842</b>
<b>Peak</b>	<b>55</b>	<b>0</b>	<b>59</b>	<b>0</b>	<b>0</b>	<b>161</b>	<b>32</b>	<b>0</b>	<b>0</b>	<b>0</b>	<b>0</b>	<b>0</b>	<b>68</b>	<b>341</b>	<b>0</b>	<b>0</b>	<b>716</b>

**Intersection Statistics**

Per	Peak Hour	Pk Hr Vol	Peak Intvl	Pk Intv Vol
AM	7:00 AM	646	7:15 AM	169
MID				
PM	4:30 PM	716	5:15 PM	199

**Approach Statistics**

Per	Peak Hour	Pk Hr Vol	Peak Hour	Pk Hr Vol	Peak Hour	Pk Hr Vol	Peak Hour	Pk Hr Vol
AM	6:45 AM	81	6:30 AM	383			7:15 AM	195
MID								
PM	4:30 PM	114	4:00 PM	197			4:30 PM	409

**Comments**

**Approach & Departure Volumes (No Peds)**

Per	Approach	Depart	Approach	Depart	Approach	Depart	Approach	Depart
AM	200	282	906	401	0	0	453	876
MID	0	0	0	0	0	0	0	0
PM	272	270	504	1005	0	0	1066	567



Intersection TMC: 1200169  
Count Date: 5/22/2012

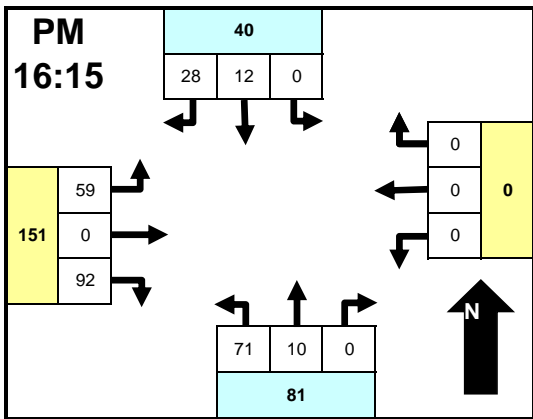
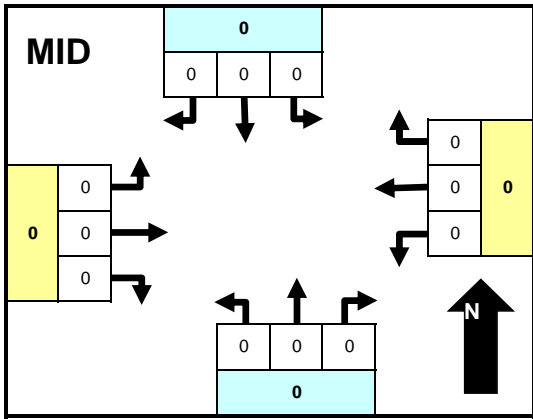
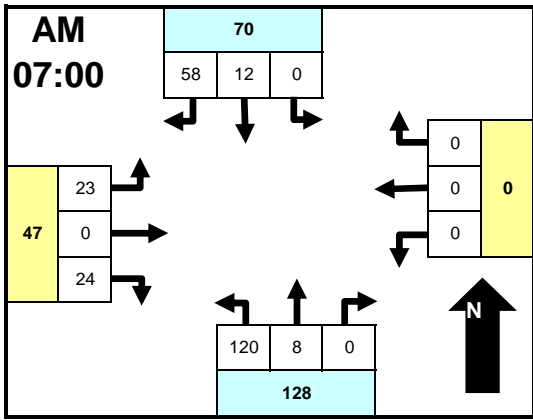

Time	From North MERIDIAN RD				From East NONE				From South MERIDIAN RD				From West ELLIOT RD				INTSEC
	LT	Thru	RT	Ped	LT	Thru	RT	Ped	LT	Thru	RT	Ped	LT	Thru	RT	Ped	
6:00	0	0	8	0	0	0	0	0	13	2	0	0	1	0	4	0	28
6:15	0	1	13	0	0	0	0	0	26	1	0	0	3	0	1	0	45
6:30	0	0	16	0	0	0	0	0	18	0	0	0	4	0	5	0	43
6:45	0	2	17	0	0	0	0	0	28	1	0	0	6	0	6	0	60
7:00	0	3	12	0	0	0	0	0	39	1	0	0	5	0	2	0	62
7:15	0	0	16	0	0	0	0	0	22	1	0	0	5	0	2	0	46
7:30	0	1	17	0	0	0	0	0	34	1	0	0	7	0	14	0	74
7:45	0	8	13	0	0	0	0	0	25	5	0	0	6	0	6	0	63
8:00	0	4	17	0	0	0	0	0	25	7	0	0	2	0	6	0	61
8:15	0	1	13	0	0	0	0	0	11	1	0	0	3	0	6	0	35
8:30	0	0	6	0	0	0	0	0	23	0	0	0	3	0	11	0	43
8:45	0	1	8	0	0	0	0	0	10	3	0	0	4	0	7	0	33
<b>Total</b>	<b>0</b>	<b>21</b>	<b>156</b>	<b>0</b>	<b>0</b>	<b>0</b>	<b>0</b>	<b>0</b>	<b>274</b>	<b>23</b>	<b>0</b>	<b>0</b>	<b>49</b>	<b>0</b>	<b>70</b>	<b>0</b>	<b>593</b>
<b>Peak</b>	<b>0</b>	<b>12</b>	<b>58</b>	<b>0</b>	<b>0</b>	<b>0</b>	<b>0</b>	<b>0</b>	<b>120</b>	<b>8</b>	<b>0</b>	<b>0</b>	<b>23</b>	<b>0</b>	<b>24</b>	<b>0</b>	<b>245</b>

Time	LT	Thru	RT	Ped	LT	Thru	RT	Ped	LT	Thru	RT	Ped	LT	Thru	RT	Ped	TOTAL
Total	0	0	0	0	0	0	0	0	0	0	0	0	0	0	0	0	0
Peak																	0

Time	LT	Thru	RT	Ped	LT	Thru	RT	Ped	LT	Thru	RT	Ped	LT	Thru	RT	Ped	TOTAL
15:30	0	0	11	0	0	0	0	0	21	0	0	0	15	0	18	0	65
15:45	0	1	7	0	0	0	0	0	12	0	0	0	8	0	28	0	56
16:00	0	2	4	0	0	0	0	0	8	1	0	0	10	0	25	0	50
16:15	0	3	6	0	0	0	0	0	23	3	0	0	14	0	26	0	75
16:30	0	6	7	0	0	0	0	0	14	4	0	0	12	0	26	0	69
16:45	0	1	9	0	0	0	0	0	20	2	0	0	19	0	13	0	64
17:00	0	2	6	0	0	0	0	0	14	1	0	0	14	0	27	0	64
17:15	0	3	7	0	0	0	0	0	7	1	0	0	17	0	27	0	62
17:30	0	0	4	0	0	0	0	0	12	0	0	0	15	0	23	0	54
17:45	0	1	5	0	0	0	0	0	11	3	0	0	11	0	22	0	53
18:00	0	1	3	0	0	0	0	0	8	0	0	0	6	0	24	0	42
18:15	0	0	6	0	0	0	0	0	12	4	0	0	17	0	18	0	57
<b>Total</b>	<b>0</b>	<b>20</b>	<b>75</b>	<b>0</b>	<b>0</b>	<b>0</b>	<b>0</b>	<b>0</b>	<b>162</b>	<b>19</b>	<b>0</b>	<b>0</b>	<b>158</b>	<b>0</b>	<b>277</b>	<b>0</b>	<b>711</b>
<b>Peak</b>	<b>0</b>	<b>12</b>	<b>28</b>	<b>0</b>	<b>0</b>	<b>0</b>	<b>0</b>	<b>0</b>	<b>71</b>	<b>10</b>	<b>0</b>	<b>0</b>	<b>59</b>	<b>0</b>	<b>92</b>	<b>0</b>	<b>272</b>

**Intersection Statistics**

Per	Peak Hour	Pk Hr Vol	Peak Intvl	Pk Intv Vol
AM	7:00 AM	245	7:30 AM	74
MID				
PM	4:15 PM	272	4:15 PM	75

**Approach Statistics**

Per	Peak Hour	Pk Hr Vol	Peak Hour	Pk Hr Vol	Peak Hour	Pk Hr Vol	Peak Hour	Pk Hr Vol
AM	7:15 AM	76			7:00 AM	128	7:30 AM	50
MID								
PM	4:30 PM	41			4:15 PM	81	5:00 PM	156

**Comments**

**Approach & Departure Volumes (No Peds)**

Per	Approach	Depart	Approach	Depart	Approach	Depart	Approach	Depart
AM	177	72	0	0	297	91	119	430
MID	0	0	0	0	0	0	0	0
PM	95	177	0	0	181	297	435	237



Intersection TMC: 1200170  
Count Date: 5/22/2012

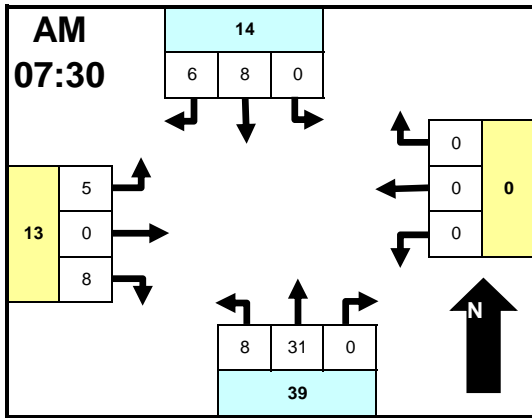

Time	From North MERIDIAN RD				From East NONE				From South MERIDIAN RD				From West WARNER RD				INTSEC	TOTAL
	LT	Thru	RT	Ped	LT	Thru	RT	Ped	LT	Thru	RT	Ped	LT	Thru	RT	Ped		
6:00	0	0	1	0	0	0	0	0	0	1	3	0	0	2	0	1	0	8
6:15	0	0	1	0	0	0	0	0	0	1	7	0	0	2	0	0	0	11
6:30	0	1	1	0	0	0	0	0	0	0	8	0	0	0	0	1	0	11
6:45	0	1	4	0	0	0	0	0	0	0	6	0	0	1	0	1	0	13
7:00	0	1	2	0	0	0	0	0	0	0	14	0	0	0	0	2	0	19
7:15	0	0	2	0	0	0	0	0	0	0	6	0	0	1	0	0	0	9
7:30	0	0	0	0	0	0	0	0	0	0	9	0	0	0	0	0	0	9
7:45	0	3	3	0	0	0	0	0	0	3	10	0	0	3	0	1	0	23
8:00	0	3	2	0	0	0	0	0	0	3	8	0	0	1	0	6	0	23
8:15	0	2	1	0	0	0	0	0	0	2	4	0	0	1	0	1	0	11
8:30	0	2	0	0	0	0	0	0	0	0	6	0	0	0	0	0	0	8
8:45	0	1	0	0	0	0	0	0	0	0	3	0	0	2	0	0	0	6
<b>Total</b>	<b>0</b>	<b>14</b>	<b>17</b>	<b>0</b>	<b>0</b>	<b>0</b>	<b>0</b>	<b>0</b>	<b>0</b>	<b>10</b>	<b>84</b>	<b>0</b>	<b>0</b>	<b>13</b>	<b>0</b>	<b>13</b>	<b>0</b>	<b>151</b>
<b>Peak</b>	<b>0</b>	<b>8</b>	<b>6</b>	<b>0</b>	<b>0</b>	<b>0</b>	<b>0</b>	<b>0</b>	<b>0</b>	<b>8</b>	<b>31</b>	<b>0</b>	<b>0</b>	<b>5</b>	<b>0</b>	<b>8</b>	<b>0</b>	<b>66</b>

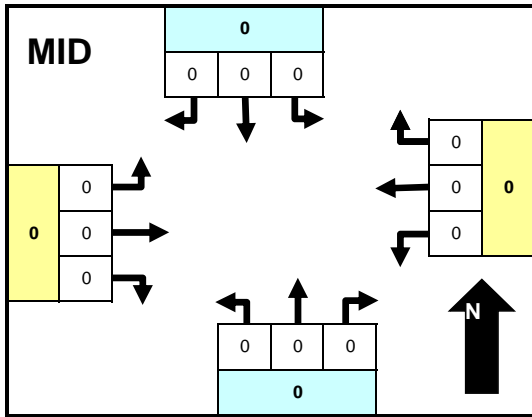

Time	LT	Thru	RT	Ped	LT	Thru	RT	Ped	LT	Thru	RT	Ped	LT	Thru	RT	Ped	TOTAL	
Total	0	0	0	0	0	0	0	0	0	0	0	0	0	0	0	0	0	0
Peak																		0

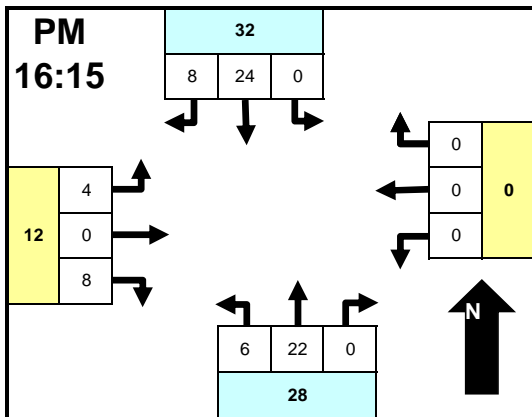

Time	LT	Thru	RT	Ped	LT	Thru	RT	Ped	LT	Thru	RT	Ped	LT	Thru	RT	Ped	TOTAL
15:30	0	4	4	0	0	0	0	0	3	4	0	0	1	0	3	0	19
15:45	0	6	2	0	0	0	0	0	0	5	0	0	1	0	2	0	16
16:00	0	4	2	0	0	0	0	0	0	4	0	0	5	0	0	0	15
16:15	0	7	1	0	0	0	0	0	0	1	7	0	2	0	2	0	20
16:30	0	4	4	0	0	0	0	0	2	4	0	0	0	0	2	0	16
16:45	0	5	2	0	0	0	0	0	0	1	9	0	0	0	1	0	18
17:00	0	8	1	0	0	0	0	0	2	2	0	0	2	0	3	0	18
17:15	0	8	3	0	0	0	0	0	0	5	0	0	1	0	0	0	17
17:30	0	4	2	0	0	1	0	0	0	4	0	0	0	0	4	0	15
17:45	0	6	2	0	0	0	0	0	0	2	0	0	2	0	3	0	15
18:00	0	6	1	0	0	0	0	0	1	2	0	0	1	0	2	0	13
18:15	0	5	2	0	0	0	0	0	1	2	0	0	1	0	3	0	14
<b>Total</b>	<b>0</b>	<b>67</b>	<b>26</b>	<b>0</b>	<b>0</b>	<b>1</b>	<b>0</b>	<b>0</b>	<b>11</b>	<b>50</b>	<b>0</b>	<b>0</b>	<b>16</b>	<b>0</b>	<b>25</b>	<b>0</b>	<b>196</b>
<b>Peak</b>	<b>0</b>	<b>24</b>	<b>8</b>	<b>0</b>	<b>0</b>	<b>0</b>	<b>0</b>	<b>0</b>	<b>6</b>	<b>22</b>	<b>0</b>	<b>0</b>	<b>4</b>	<b>0</b>	<b>8</b>	<b>0</b>	<b>72</b>

**Intersection Statistics**

Per	Peak Hour	Pk Hr Vol	Peak Intvl	Pk Intv Vol
AM	7:30 AM	66	7:45 AM	23
MID				
PM	4:15 PM	72	4:15 PM	20

**Approach Statistics**

Per	Peak Hour	Pk Hr Vol	Peak Hour	Pk Hr Vol	Peak Hour	Pk Hr Vol	Peak Hour	Pk Hr Vol
AM	7:45 AM	16			7:00 AM	42	7:30 AM	13
MID								
PM	4:30 PM	35	4:45 PM	1	4:00 PM	28	3:30 PM	16

**Comments**

**Approach & Departure Volumes (No Peds)**

Per	Approach	Depart	Approach	Depart	Approach	Depart	Approach	Depart
AM	31	97	0	0	94	27	26	27
MID	0	0	0	0	0	0	0	0
PM	93	66	1	0	61	92	41	38

Traffic Research and Analysis, Inc.  
3844 East Indian School Road  
Phoenix, AZ 85018  
(602) 840-1500

File Name	Route	Location	Direction	Count Dur	Start Date	Avg Vol	AM PkHr	AM PkVol	AM PHF	PM PkHr	PM PkVol	PM PHF	Day Corr	Dir Split	Avg Spd	Latitude
1201307	MERIDIAN RD	Btwn MCDOWELL RD & MCKELLIPS RD	NB	48	5/22/2012	510	6:45	52	0.9375	13:00	33	0.8250	0.6323	48.3%	37.3	33.4529
1201308	MERIDIAN RD	Btwn MCDOWELL RD & MCKELLIPS RD	SB	48	5/22/2012	546	11:30	42	0.9130	16:45	56	0.7708	0.7418	51.7%	40.5	33.4529
1201309	MERIDIAN RD	Btwn MCKELLIPS RD & BROWN RD	NB	48	5/22/2012	1278	11:45	82	0.8913	16:45	142	0.9500	0.8790	48.4%	45.9	33.4415
1201310	MERIDIAN RD	Btwn MCKELLIPS RD & BROWN RD	SB	48	5/22/2012	1360	6:45	154	0.9029	17:00	80	0.8944	0.8470	51.6%	56.8	33.4415
1201311	MERIDIAN RD	Btwn BROWN RD & UNIVERSITY DR	NB	48	5/22/2012	2256	11:45	141	0.8598	16:30	212	0.8638	0.9304	48.2%	36.4	33.4249
1201312	MERIDIAN RD	Btwn BROWN RD & UNIVERSITY DR	SB	48	5/22/2012	2428	7:00	208	0.8476	15:45	174	0.8788	0.9157	51.8%	42.7	33.4249
1201319	MERIDIAN RD	Btwn UNIVERSITY DR & APACHE TRAIL	NB	48	5/22/2012	2912	11:15	212	0.8740	16:15	256	0.9143	0.9355	51.0%	39.2	33.4191
1201320	MERIDIAN RD	Btwn UNIVERSITY DR & APACHE TRAIL	SB	48	5/22/2012	2793	10:00	198	0.9706	15:45	224	0.9803	0.9304	49.0%	40.0	33.4191
1201321	MERIDIAN RD	Btwn APACHE TRAIL & BROADWAY RD	NB	48	5/22/2012	2792	11:15	210	0.9437	16:00	232	0.9260	0.9552	47.7%	34.9	33.4114
1201322	MERIDIAN RD	Btwn APACHE TRAIL & BROADWAY RD	SB	48	5/22/2012	3061	11:15	244	0.9173	16:00	258	0.9485	0.9395	52.3%	35.3	33.4114
1201315	MERIDIAN RD	Btwn BROADWAY RD & SOUTHERN AVE	NB	48	5/22/2012	2194	11:15	170	0.9341	13:45	198	0.8161	0.9260	51.6%	36.8	33.3990
1201316	MERIDIAN RD	Btwn BROADWAY RD & SOUTHERN AVE	SB	48	5/22/2012	2056	11:15	163	0.9261	16:30	156	0.8892	0.9101	48.4%	43.3	33.3990
1201317	MERIDIAN RD	Btwn SOUTHERN AVE & BASELINE RD	NB	48	5/22/2012	1308	7:00	121	0.8403	15:15	122	0.7500	0.9076	51.2%	49.9	33.3893
1201318	MERIDIAN RD	Btwn SOUTHERN AVE & BASELINE RD	SB	48	5/22/2012	1246	11:15	91	0.9100	16:30	102	0.9273	0.8582	48.8%	43.6	33.3893
1201325	MERIDIAN RD	N of ELLIOT RD	NB	48	5/22/2012	609	11:30	34	0.8947	16:15	63	0.9000	0.7747	51.2%	37.4	33.3515
1201326	MERIDIAN RD	N of ELLIOT RD	SB	48	5/22/2012	581	6:45	76	0.8138	14:30	40	0.8438	0.7961	48.8%	42.1	33.3515
1201323	MERIDIAN RD	Btwn ELLIOT RD & WARNER RD	NB	48	5/22/2012	651	7:00	80	0.7143	16:15	50	0.8250	0.8459	52.3%	47.0	33.3404
1201324	MERIDIAN RD	Btwn ELLIOT RD & WARNER RD	SB	48	5/22/2012	594	11:30	36	0.8068	16:30	67	0.9306	0.7919	47.7%	47.6	33.3404



Traffic Research and Analysis, Inc.  
 3844 East Indian School Road  
 Phoenix, AZ 85018  
 (602) 840-1500

File Name	Route	Location	Direction	Longitude	Comments
1201307	MERIDIAN RD	Btwn MCDOWELL RD & MCKELLIPS RD	NB	-111.5807	
1201308	MERIDIAN RD	Btwn MCDOWELL RD & MCKELLIPS RD	SB	-111.5807	
1201309	MERIDIAN RD	Btwn MCKELLIPS RD & BROWN RD	NB	-111.5806	
1201310	MERIDIAN RD	Btwn MCKELLIPS RD & BROWN RD	SB	-111.5806	
1201311	MERIDIAN RD	Btwn BROWN RD & UNIVERSITY DR	NB	-111.5806	
1201312	MERIDIAN RD	Btwn BROWN RD & UNIVERSITY DR	SB	-111.5806	
1201319	MERIDIAN RD	Btwn UNIVERSITY DR & APACHE TRAIL	NB	-111.5806	
1201320	MERIDIAN RD	Btwn UNIVERSITY DR & APACHE TRAIL	SB	-111.5806	
1201321	MERIDIAN RD	Btwn APACHE TRAIL & BROADWAY RD	NB	-111.5806	
1201322	MERIDIAN RD	Btwn APACHE TRAIL & BROADWAY RD	SB	-111.5806	
1201315	MERIDIAN RD	Btwn BROADWAY RD & SOUTHERN AVE	NB	-111.5805	
1201316	MERIDIAN RD	Btwn BROADWAY RD & SOUTHERN AVE	SB	-111.5805	
1201317	MERIDIAN RD	Btwn SOUTHERN AVE & BASELINE RD	NB	-111.5806	
1201318	MERIDIAN RD	Btwn SOUTHERN AVE & BASELINE RD	SB	-111.5806	
1201325	MERIDIAN RD	N of ELLIOT RD	NB	-111.5838	
1201326	MERIDIAN RD	N of ELLIOT RD	SB	-111.5838	
1201323	MERIDIAN RD	Btwn ELLIOT RD & WARNER RD	NB	-111.5837	
1201324	MERIDIAN RD	Btwn ELLIOT RD & WARNER RD	SB	-111.5837	

**TRAFFIC COUNT SUMMARY**

Site ID: 1  
 Location 1: MERIDIAN RD  
 Location 2: Btwn MCDOWELL RD & MCKELLIPS RD  
 Latitude: 33.45288 33.45288  
 Longitude: -111.58069 -111.58069

File Ref: 1201307 1201308  
 Start Date: Average Average **Combined Totals**

Direction:	NB	SB	NB/SB	Total
12:00 AM	2	1	3	3
12:15 AM	2	2	4	4
12:30 AM	1	1	1	1
12:45 AM	1	2	3	3
1:00 AM	1	3	4	4
1:15 AM	2	3	5	5
1:30 AM	1	2	2	2
1:45 AM	2	1	3	3
2:00 AM	1	1	2	2
2:15 AM	0	0	0	0
2:30 AM	0	1	1	1
2:45 AM	0	0	0	0
3:00 AM	0	2	2	2
3:15 AM	2	0	2	2
3:30 AM	1	0	1	1
3:45 AM	2	1	2	2
4:00 AM	2	2	3	3
4:15 AM	4	0	4	4
4:30 AM	2	1	2	2
4:45 AM	4	1	5	5
5:00 AM	5	2	6	6
5:15 AM	7	3	9	9
5:30 AM	7	2	9	9
5:45 AM	4	0	4	4
6:00 AM	7	3	10	10
6:15 AM	7	2	9	9
6:30 AM	9	4	13	13
6:45 AM	14	3	17	17
7:00 AM	12	4	16	16
7:15 AM	14	4	18	18
7:30 AM	13	3	16	16
7:45 AM	10	9	19	19
8:00 AM	11	4	15	15
8:15 AM	9	4	12	12
8:30 AM	10	7	17	17
8:45 AM	9	5	14	14
9:00 AM	6	7	13	13
9:15 AM	8	5	12	12
9:30 AM	9	8	16	16
9:45 AM	7	6	13	13
10:00 AM	8	8	15	15
10:15 AM	9	6	15	15
10:30 AM	7	8	15	15
10:45 AM	7	7	14	14
11:00 AM	10	6	16	16
11:15 AM	10	9	18	18
11:30 AM	8	11	19	19
11:45 AM	6	9	14	14

File Ref:	1201307	1201308	<b>Combined Totals</b>	
Start Date:	Average	Average		
Direction:	<b>NB</b>	<b>SB</b>	<b>NB/SB</b>	<b>Total</b>
12:00 PM	11	11	22	22
12:15 PM	6	12	18	18
12:30 PM	8	11	19	19
12:45 PM	6	10	16	16
1:00 PM	9	7	16	16
1:15 PM	8	9	17	17
1:30 PM	7	9	16	16
1:45 PM	10	11	21	21
2:00 PM	8	9	17	17
2:15 PM	5	13	17	17
2:30 PM	6	12	18	18
2:45 PM	9	8	16	16
3:00 PM	6	14	20	20
3:15 PM	5	13	18	18
3:30 PM	7	7	13	13
3:45 PM	9	10	19	19
4:00 PM	7	7	14	14
4:15 PM	9	9	18	18
4:30 PM	7	12	18	18
4:45 PM	5	16	21	21
5:00 PM	6	11	16	16
5:15 PM	5	12	17	17
5:30 PM	7	18	25	25
5:45 PM	10	13	23	23
6:00 PM	9	8	16	16
6:15 PM	5	11	16	16
6:30 PM	3	9	11	11
6:45 PM	6	5	11	11
7:00 PM	4	10	14	14
7:15 PM	8	9	17	17
7:30 PM	6	9	15	15
7:45 PM	5	10	15	15
8:00 PM	6	9	15	15
8:15 PM	6	4	9	9
8:30 PM	2	5	7	7
8:45 PM	1	5	6	6
9:00 PM	2	7	9	9
9:15 PM	4	3	7	7
9:30 PM	3	2	5	5
9:45 PM	2	3	5	5
10:00 PM	3	3	6	6
10:15 PM	1	5	5	5
10:30 PM	2	4	6	6
10:45 PM	2	3	5	5
11:00 PM	1	4	5	5
11:15 PM	1	1	2	2
11:30 PM	0	3	3	3
11:45 PM	1	2	3	3
<b>Total:</b>	<b>511</b>	<b>546</b>	<b>1056</b>	<b>1056</b>
AM Peak Hr:	6:45 AM	11:30 AM	11:45 AM	11:45 AM
AM Peak Vol:	52.5	42	73	73
AM PHF:	0.9375	0.9130	0.8295	0.8295
PM Peak Hr:	1:00 PM	4:45 PM	5:00 PM	5:00 PM
PM Peak Vol:	33	55.5	80	80
PM PHF:	0.8250	0.7708	0.8000	0.8000

**TRAFFIC COUNT SUMMARY**

Site ID:	2	
Location 1:	MERIDIAN RD	
Location 2:	Btwn MCKELLIPS RD & BROWN RD	
Latitude:	33.44152	33.44152
Longitude:	-111.58058	-111.58058

File Ref:	1201309	1201310	
Start Date:	Average	Average	<b>Combined Totals</b>

Direction:	NB	SB	NB/SB	Total
12:00 AM	2	2	4	4
12:15 AM	4	3	7	7
12:30 AM	1	1	2	2
12:45 AM	5	2	6	6
1:00 AM	4	3	6	6
1:15 AM	4	2	5	5
1:30 AM	3	1	4	4
1:45 AM	1	3	4	4
2:00 AM	2	1	3	3
2:15 AM	0	3	3	3
2:30 AM	1	1	1	1
2:45 AM	1	1	2	2
3:00 AM	2	3	5	5
3:15 AM	0	3	3	3
3:30 AM	1	3	3	3
3:45 AM	2	3	5	5
4:00 AM	2	7	9	9
4:15 AM	2	12	14	14
4:30 AM	1	10	11	11
4:45 AM	1	12	13	13
5:00 AM	5	15	20	20
5:15 AM	8	23	31	31
5:30 AM	9	22	31	31
5:45 AM	4	19	23	23
6:00 AM	6	17	22	22
6:15 AM	4	29	33	33
6:30 AM	13	29	42	42
6:45 AM	6	37	43	43
7:00 AM	7	38	45	45
7:15 AM	9	36	45	45
7:30 AM	11	43	53	53
7:45 AM	18	30	47	47
8:00 AM	12	30	41	41
8:15 AM	6	26	31	31
8:30 AM	11	23	34	34
8:45 AM	9	23	32	32
9:00 AM	16	21	37	37
9:15 AM	17	21	37	37
9:30 AM	14	20	34	34
9:45 AM	14	21	34	34
10:00 AM	14	20	33	33
10:15 AM	15	23	38	38
10:30 AM	14	20	34	34
10:45 AM	18	19	37	37
11:00 AM	11	20	31	31
11:15 AM	18	18	36	36
11:30 AM	18	15	33	33
11:45 AM	22	17	38	38



File Ref:	1201309	1201310	Combined Totals	
Start Date:	Average	Average		
Direction:	NB	SB	NB/SB	Total
12:00 PM	20	22	42	42
12:15 PM	18	19	36	36
12:30 PM	23	17	40	40
12:45 PM	16	20	36	36
1:00 PM	19	16	35	35
1:15 PM	17	18	35	35
1:30 PM	17	18	35	35
1:45 PM	24	20	44	44
2:00 PM	21	16	37	37
2:15 PM	28	13	41	41
2:30 PM	26	19	45	45
2:45 PM	25	18	43	43
3:00 PM	32	13	45	45
3:15 PM	29	16	44	44
3:30 PM	24	21	45	45
3:45 PM	28	22	49	49
4:00 PM	29	21	50	50
4:15 PM	28	17	45	45
4:30 PM	30	17	47	47
4:45 PM	31	17	48	48
5:00 PM	38	23	60	60
5:15 PM	37	21	58	58
5:30 PM	37	17	54	54
5:45 PM	25	20	45	45
6:00 PM	25	16	41	41
6:15 PM	25	12	36	36
6:30 PM	18	14	32	32
6:45 PM	16	11	27	27
7:00 PM	21	11	32	32
7:15 PM	22	13	35	35
7:30 PM	17	14	30	30
7:45 PM	22	11	33	33
8:00 PM	15	11	26	26
8:15 PM	14	10	24	24
8:30 PM	10	10	20	20
8:45 PM	9	8	17	17
9:00 PM	17	8	25	25
9:15 PM	13	7	20	20
9:30 PM	6	8	14	14
9:45 PM	8	5	13	13
10:00 PM	7	7	14	14
10:15 PM	6	3	9	9
10:30 PM	10	2	12	12
10:45 PM	8	3	11	11
11:00 PM	9	3	11	11
11:15 PM	5	2	7	7
11:30 PM	4	1	5	5
11:45 PM	4	1	4	4
<b>Total:</b>	<b>1278</b>	<b>1360</b>	<b>2638</b>	<b>2638</b>
AM Peak Hr:	11:45 AM	6:45 AM	7:00 AM	7:00 AM
AM Peak Vol:	82	153.5	188	188
AM PHF:	0.8913	0.9029	0.8868	0.8868
PM Peak Hr:	4:45 PM	5:00 PM	4:45 PM	4:45 PM
PM Peak Vol:	142.5	80.5	220	220
PM PHF:	0.9500	0.8944	0.9167	0.9167

**TRAFFIC COUNT SUMMARY**

Site ID:	3	
Location 1:	MERIDIAN RD	
Location 2:	Btwn BROWN RD & UNIVERSITY DR	
Latitude:	33.42492	33.42492
Longitude:	-111.58058	-111.58058

File Ref:	1201311	1201312	
Start Date:	Average	Average	<b>Combined Totals</b>

Direction:	NB	SB	NB/SB	Total
12:00 AM	4	5	9	9
12:15 AM	4	3	7	7
12:30 AM	2	2	3	3
12:45 AM	4	3	6	6
1:00 AM	5	1	6	6
1:15 AM	3	4	7	7
1:30 AM	4	3	7	7
1:45 AM	3	2	5	5
2:00 AM	4	5	8	8
2:15 AM	2	4	5	5
2:30 AM	2	2	4	4
2:45 AM	4	3	7	7
3:00 AM	1	3	4	4
3:15 AM	1	1	2	2
3:30 AM	2	5	6	6
3:45 AM	2	5	7	7
4:00 AM	2	11	13	13
4:15 AM	2	11	13	13
4:30 AM	2	10	12	12
4:45 AM	3	10	13	13
5:00 AM	6	17	22	22
5:15 AM	7	24	31	31
5:30 AM	9	24	33	33
5:45 AM	6	12	18	18
6:00 AM	14	24	38	38
6:15 AM	10	27	37	37
6:30 AM	14	29	42	42
6:45 AM	13	31	43	43
7:00 AM	19	45	64	64
7:15 AM	14	57	71	71
7:30 AM	24	62	86	86
7:45 AM	21	46	67	67
8:00 AM	28	41	69	69
8:15 AM	25	47	72	72
8:30 AM	22	39	60	60
8:45 AM	26	41	67	67
9:00 AM	23	44	66	66
9:15 AM	33	37	70	70
9:30 AM	21	36	57	57
9:45 AM	26	32	57	57
10:00 AM	29	42	71	71
10:15 AM	27	41	67	67
10:30 AM	27	45	72	72
10:45 AM	27	38	64	64
11:00 AM	29	41	70	70
11:15 AM	42	33	75	75
11:30 AM	37	33	69	69
11:45 AM	34	38	72	72

File Ref:	1201311	1201312	Combined Totals	
Start Date:	Average	Average		
Direction:	NB	SB	NB/SB	Total
12:00 PM	29	33	61	61
12:15 PM	41	36	77	77
12:30 PM	38	35	72	72
12:45 PM	33	40	73	73
1:00 PM	32	37	68	68
1:15 PM	43	37	79	79
1:30 PM	36	35	71	71
1:45 PM	40	38	78	78
2:00 PM	32	37	69	69
2:15 PM	39	31	70	70
2:30 PM	42	33	75	75
2:45 PM	50	35	85	85
3:00 PM	49	36	85	85
3:15 PM	52	37	88	88
3:30 PM	43	37	80	80
3:45 PM	51	44	95	95
4:00 PM	45	50	95	95
4:15 PM	49	43	91	91
4:30 PM	57	39	95	95
4:45 PM	50	41	90	90
5:00 PM	45	43	88	88
5:15 PM	62	52	113	113
5:30 PM	49	29	78	78
5:45 PM	44	33	77	77
6:00 PM	41	30	71	71
6:15 PM	39	29	68	68
6:30 PM	41	27	67	67
6:45 PM	32	25	56	56
7:00 PM	37	22	58	58
7:15 PM	36	28	64	64
7:30 PM	29	27	55	55
7:45 PM	32	30	61	61
8:00 PM	30	30	60	60
8:15 PM	29	24	53	53
8:30 PM	21	21	42	42
8:45 PM	26	18	44	44
9:00 PM	27	15	42	42
9:15 PM	18	18	36	36
9:30 PM	16	13	29	29
9:45 PM	19	14	33	33
10:00 PM	15	11	26	26
10:15 PM	16	10	25	25
10:30 PM	13	9	22	22
10:45 PM	12	6	18	18
11:00 PM	11	8	19	19
11:15 PM	7	6	12	12
11:30 PM	9	5	14	14
11:45 PM	4	3	6	6
<b>Total:</b>	<b>2256</b>	<b>2429</b>	<b>4684</b>	<b>4684</b>
AM Peak Hr:	11:45 AM	7:00 AM	7:30 AM	7:30 AM
AM Peak Vol:	141	208.5	292	292
AM PHF:	0.8598	0.8476	0.8488	0.8488
PM Peak Hr:	4:30 PM	3:45 PM	4:30 PM	4:30 PM
PM Peak Vol:	212.5	174	386	386
PM PHF:	0.8638	0.8788	0.8540	0.8540

**TRAFFIC COUNT SUMMARY**

Site ID: 4  
 Location 1: MERIDIAN RD  
 Location 2: Btwn UNIVERSITY DR & APACHE TRAIL  
 Latitude: 33.41909 33.41909  
 Longitude: -111.58056 -111.58056

File Ref: 1201319 1201320  
 Start Date: Average Average **Combined Totals**

Direction:	NB	SB	NB/SB	Total
12:00 AM	5	5	10	10
12:15 AM	6	4	9	9
12:30 AM	2	3	5	5
12:45 AM	3	2	5	5
1:00 AM	1	2	2	2
1:15 AM	3	2	4	4
1:30 AM	4	2	6	6
1:45 AM	3	5	8	8
2:00 AM	1	3	3	3
2:15 AM	1	1	2	2
2:30 AM	2	0	2	2
2:45 AM	2	2	3	3
3:00 AM	1	1	2	2
3:15 AM	1	1	2	2
3:30 AM	2	3	5	5
3:45 AM	2	4	5	5
4:00 AM	6	3	8	8
4:15 AM	2	5	6	6
4:30 AM	5	6	11	11
4:45 AM	7	8	14	14
5:00 AM	9	11	20	20
5:15 AM	9	8	17	17
5:30 AM	10	15	24	24
5:45 AM	11	15	25	25
6:00 AM	13	14	27	27
6:15 AM	17	23	40	40
6:30 AM	18	25	43	43
6:45 AM	18	22	39	39
7:00 AM	27	35	61	61
7:15 AM	30	43	73	73
7:30 AM	34	47	81	81
7:45 AM	27	47	74	74
8:00 AM	54	43	97	97
8:15 AM	37	49	86	86
8:30 AM	43	45	88	88
8:45 AM	48	47	95	95
9:00 AM	39	43	81	81
9:15 AM	43	43	85	85
9:30 AM	33	39	72	72
9:45 AM	43	45	87	87
10:00 AM	49	51	100	100
10:15 AM	42	50	91	91
10:30 AM	39	48	87	87
10:45 AM	39	50	89	89
11:00 AM	42	48	90	90
11:15 AM	61	46	107	107
11:30 AM	53	46	99	99
11:45 AM	45	55	100	100



File Ref:	1201319	1201320	<b>Combined Totals</b>	
Start Date:	Average	Average		
Direction:	<b>NB</b>	<b>SB</b>	<b>NB/SB</b>	<b>Total</b>
12:00 PM	54	49	103	103
12:15 PM	55	44	99	99
12:30 PM	47	49	96	96
12:45 PM	51	55	105	105
1:00 PM	51	49	100	100
1:15 PM	56	51	107	107
1:30 PM	58	47	104	104
1:45 PM	57	56	113	113
2:00 PM	53	41	93	93
2:15 PM	49	46	95	95
2:30 PM	58	52	110	110
2:45 PM	54	54	108	108
3:00 PM	56	56	112	112
3:15 PM	56	52	108	108
3:30 PM	59	54	112	112
3:45 PM	59	57	115	115
4:00 PM	51	57	108	108
4:15 PM	70	56	126	126
4:30 PM	66	54	120	120
4:45 PM	59	51	110	110
5:00 PM	62	53	115	115
5:15 PM	61	49	110	110
5:30 PM	55	43	98	98
5:45 PM	46	46	91	91
6:00 PM	51	45	95	95
6:15 PM	46	43	89	89
6:30 PM	47	37	84	84
6:45 PM	40	31	70	70
7:00 PM	41	28	69	69
7:15 PM	36	26	62	62
7:30 PM	31	31	62	62
7:45 PM	37	30	67	67
8:00 PM	40	27	66	66
8:15 PM	25	25	49	49
8:30 PM	30	26	56	56
8:45 PM	22	17	39	39
9:00 PM	24	17	40	40
9:15 PM	16	17	33	33
9:30 PM	14	13	26	26
9:45 PM	17	15	32	32
10:00 PM	18	16	34	34
10:15 PM	15	7	22	22
10:30 PM	8	6	14	14
10:45 PM	10	6	16	16
11:00 PM	14	7	21	21
11:15 PM	7	4	11	11
11:30 PM	9	4	13	13
11:45 PM	4	5	9	9
<b>Total:</b>	<b>2912</b>	<b>2793</b>	<b>5704</b>	<b>5704</b>
AM Peak Hr:	11:15 AM	10:00 AM	11:15 AM	11:15 AM
AM Peak Vol:	211.5	198	406	406
AM PHF:	0.8740	0.9706	0.9575	0.9575
PM Peak Hr:	4:15 PM	3:45 PM	4:15 PM	4:15 PM
PM Peak Vol:	256	223.5	471	471
PM PHF:	0.9143	0.9803	0.9345	0.9345

**TRAFFIC COUNT SUMMARY**

Site ID: 5  
 Location 1: MERIDIAN RD  
 Location 2: Btwn APACHE TRAIL & BROADWAY RD  
 Latitude: 33.41137 33.41137  
 Longitude: -111.58061 -111.58061

File Ref: 1201321 1201322  
 Start Date: Average Average **Combined Totals**

Direction:	NB	SB	NB/SB	Total
12:00 AM	3	4	7	7
12:15 AM	5	3	8	8
12:30 AM	3	3	6	6
12:45 AM	4	4	8	8
1:00 AM	2	1	2	2
1:15 AM	2	1	3	3
1:30 AM	2	4	6	6
1:45 AM	2	3	5	5
2:00 AM	2	2	4	4
2:15 AM	1	0	1	1
2:30 AM	2	2	3	3
2:45 AM	2	1	2	2
3:00 AM	0	1	1	1
3:15 AM	2	1	2	2
3:30 AM	4	2	6	6
3:45 AM	3	2	5	5
4:00 AM	4	2	6	6
4:15 AM	6	2	8	8
4:30 AM	6	4	10	10
4:45 AM	10	9	18	18
5:00 AM	12	9	21	21
5:15 AM	10	9	19	19
5:30 AM	9	9	18	18
5:45 AM	11	12	22	22
6:00 AM	12	14	26	26
6:15 AM	21	21	42	42
6:30 AM	19	17	35	35
6:45 AM	20	26	45	45
7:00 AM	31	28	59	59
7:15 AM	39	31	70	70
7:30 AM	33	39	71	71
7:45 AM	36	53	89	89
8:00 AM	28	46	73	73
8:15 AM	36	50	86	86
8:30 AM	33	58	90	90
8:45 AM	38	65	103	103
9:00 AM	41	54	95	95
9:15 AM	45	54	99	99
9:30 AM	44	55	99	99
9:45 AM	45	51	96	96
10:00 AM	39	60	99	99
10:15 AM	53	50	103	103
10:30 AM	48	57	105	105
10:45 AM	53	48	100	100
11:00 AM	48	52	100	100
11:15 AM	56	61	117	117
11:30 AM	51	62	113	113
11:45 AM	50	55	105	105

File Ref:	1201321	1201322	<b>Combined Totals</b>	
Start Date:	Average	Average		
Direction:	<b>NB</b>	<b>SB</b>	<b>NB/SB</b>	<b>Total</b>
12:00 PM	54	67	120	120
12:15 PM	49	51	100	100
12:30 PM	47	64	111	111
12:45 PM	47	57	104	104
1:00 PM	55	54	109	109
1:15 PM	46	50	96	96
1:30 PM	47	64	111	111
1:45 PM	53	60	112	112
2:00 PM	50	58	108	108
2:15 PM	49	65	114	114
2:30 PM	55	64	119	119
2:45 PM	59	52	111	111
3:00 PM	53	64	117	117
3:15 PM	45	58	103	103
3:30 PM	53	44	96	96
3:45 PM	51	64	114	114
4:00 PM	58	63	121	121
4:15 PM	63	65	127	127
4:30 PM	60	63	122	122
4:45 PM	52	68	120	120
5:00 PM	56	51	107	107
5:15 PM	62	56	118	118
5:30 PM	48	44	92	92
5:45 PM	49	35	84	84
6:00 PM	50	40	90	90
6:15 PM	50	45	95	95
6:30 PM	33	40	72	72
6:45 PM	46	37	83	83
7:00 PM	39	35	74	74
7:15 PM	34	31	65	65
7:30 PM	23	35	58	58
7:45 PM	32	34	66	66
8:00 PM	29	26	55	55
8:15 PM	35	21	56	56
8:30 PM	24	24	48	48
8:45 PM	14	17	31	31
9:00 PM	17	19	36	36
9:15 PM	16	16	32	32
9:30 PM	16	14	30	30
9:45 PM	18	12	30	30
10:00 PM	10	14	24	24
10:15 PM	9	13	22	22
10:30 PM	10	6	15	15
10:45 PM	6	6	12	12
11:00 PM	5	8	13	13
11:15 PM	5	5	10	10
11:30 PM	2	4	6	6
11:45 PM	4	3	7	7
<b>Total:</b>	<b>2792</b>	<b>3061</b>	<b>5853</b>	<b>5853</b>
AM Peak Hr:	11:15 AM	11:15 AM	11:15 AM	11:15 AM
AM Peak Vol:	209.5	244	452	452
AM PHF:	0.9437	0.9173	0.9417	0.9417
PM Peak Hr:	4:00 PM	4:00 PM	4:00 PM	4:00 PM
PM Peak Vol:	231.5	258	489	489
PM PHF:	0.9260	0.9485	0.9626	0.9626

**TRAFFIC COUNT SUMMARY**

Site ID: 6  
 Location 1: MERIDIAN RD  
 Location 2: Btwn BROADWAY RD & SOUTHERN AVE  
 Latitude: 33.39895 33.39895  
 Longitude: -111.58054 -111.58054

File Ref: 1201315 1201316  
 Start Date: Average Average **Combined Totals**

Direction:	NB	SB	NB/SB	Total
12:00 AM	2	3	5	5
12:15 AM	3	1	3	3
12:30 AM	2	0	2	2
12:45 AM	2	2	4	4
1:00 AM	0	0	0	0
1:15 AM	0	1	1	1
1:30 AM	1	1	1	1
1:45 AM	3	1	4	4
2:00 AM	1	1	2	2
2:15 AM	1	1	1	1
2:30 AM	0	0	0	0
2:45 AM	1	1	1	1
3:00 AM	0	2	2	2
3:15 AM	1	2	3	3
3:30 AM	2	2	4	4
3:45 AM	2	3	5	5
4:00 AM	1	4	5	5
4:15 AM	2	4	6	6
4:30 AM	3	9	11	11
4:45 AM	5	13	18	18
5:00 AM	4	13	16	16
5:15 AM	3	17	20	20
5:30 AM	4	12	16	16
5:45 AM	8	15	23	23
6:00 AM	10	10	20	20
6:15 AM	10	15	25	25
6:30 AM	13	18	31	31
6:45 AM	19	29	48	48
7:00 AM	17	32	48	48
7:15 AM	32	46	78	78
7:30 AM	44	49	93	93
7:45 AM	39	31	70	70
8:00 AM	25	28	52	52
8:15 AM	34	26	60	60
8:30 AM	42	34	76	76
8:45 AM	44	32	76	76
9:00 AM	29	29	58	58
9:15 AM	31	41	72	72
9:30 AM	35	36	71	71
9:45 AM	38	29	67	67
10:00 AM	43	39	81	81
10:15 AM	36	39	75	75
10:30 AM	33	35	68	68
10:45 AM	31	37	68	68
11:00 AM	38	32	70	70
11:15 AM	45	44	89	89
11:30 AM	46	44	89	89
11:45 AM	40	36	75	75

File Ref:	1201315	1201316	<b>Combined Totals</b>	
Start Date:	Average	Average		
Direction:	<b>NB</b>	<b>SB</b>	<b>NB/SB</b>	<b>Total</b>
12:00 PM	41	40	81	81
12:15 PM	34	29	63	63
12:30 PM	51	34	84	84
12:45 PM	35	35	70	70
1:00 PM	37	35	72	72
1:15 PM	33	39	71	71
1:30 PM	43	39	82	82
1:45 PM	49	37	86	86
2:00 PM	43	41	83	83
2:15 PM	61	33	93	93
2:30 PM	46	36	81	81
2:45 PM	41	43	84	84
3:00 PM	45	35	80	80
3:15 PM	38	36	74	74
3:30 PM	36	39	75	75
3:45 PM	45	35	80	80
4:00 PM	53	33	86	86
4:15 PM	46	39	84	84
4:30 PM	48	44	92	92
4:45 PM	49	34	83	83
5:00 PM	35	39	74	74
5:15 PM	42	41	82	82
5:30 PM	29	31	60	60
5:45 PM	32	30	62	62
6:00 PM	39	33	71	71
6:15 PM	32	33	64	64
6:30 PM	27	20	46	46
6:45 PM	33	24	57	57
7:00 PM	27	21	48	48
7:15 PM	22	23	45	45
7:30 PM	29	11	40	40
7:45 PM	26	16	41	41
8:00 PM	16	17	32	32
8:15 PM	13	22	35	35
8:30 PM	13	14	27	27
8:45 PM	14	7	21	21
9:00 PM	12	7	19	19
9:15 PM	7	14	20	20
9:30 PM	11	8	19	19
9:45 PM	11	9	19	19
10:00 PM	10	7	17	17
10:15 PM	6	4	10	10
10:30 PM	10	5	15	15
10:45 PM	10	2	11	11
11:00 PM	7	3	10	10
11:15 PM	2	3	5	5
11:30 PM	3	0	3	3
11:45 PM	3	1	4	4
<b>Total:</b>	<b>2194</b>	<b>2057</b>	<b>4250</b>	<b>4250</b>
AM Peak Hr:	11:15 AM	11:15 AM	11:15 AM	11:15 AM
AM Peak Vol:	170	163	332	332
AM PHF:	0.9341	0.9261	0.9326	0.9326
PM Peak Hr:	1:45 PM	4:30 PM	1:30 PM	1:30 PM
PM Peak Vol:	197.5	156.5	344	344
PM PHF:	0.8161	0.8892	0.9247	0.9247



**TRAFFIC COUNT SUMMARY**

Site ID:	7	
Location 1:	MERIDIAN RD	
Location 2:	Btwn SOUTHERN AVE & BASELINE RD	
Latitude:	33.38927	33.38927
Longitude:	-111.58058	-111.58058

File Ref:	1201317	1201318	
Start Date:	Average	Average	<b>Combined Totals</b>

Direction:	NB	SB	NB/SB	Total
12:00 AM	1	1	1	1
12:15 AM	3	0	3	3
12:30 AM	0	0	0	0
12:45 AM	0	1	1	1
1:00 AM	0	1	1	1
1:15 AM	1	2	3	3
1:30 AM	0	0	0	0
1:45 AM	1	1	1	1
2:00 AM	1	1	1	1
2:15 AM	0	0	0	0
2:30 AM	1	0	1	1
2:45 AM	0	1	1	1
3:00 AM	0	2	2	2
3:15 AM	0	2	2	2
3:30 AM	0	4	4	4
3:45 AM	1	5	6	6
4:00 AM	1	0	1	1
4:15 AM	1	4	4	4
4:30 AM	3	8	11	11
4:45 AM	3	13	16	16
5:00 AM	4	11	15	15
5:15 AM	2	9	11	11
5:30 AM	7	9	15	15
5:45 AM	10	13	23	23
6:00 AM	8	11	18	18
6:15 AM	7	10	17	17
6:30 AM	12	15	26	26
6:45 AM	26	19	45	45
7:00 AM	22	17	39	39
7:15 AM	32	21	53	53
7:30 AM	32	22	53	53
7:45 AM	36	21	57	57
8:00 AM	21	20	40	40
8:15 AM	25	17	42	42
8:30 AM	33	18	51	51
8:45 AM	20	15	34	34
9:00 AM	21	21	41	41
9:15 AM	14	17	31	31
9:30 AM	25	21	46	46
9:45 AM	21	20	41	41
10:00 AM	24	22	45	45
10:15 AM	19	23	41	41
10:30 AM	22	19	40	40
10:45 AM	15	23	37	37
11:00 AM	17	14	31	31
11:15 AM	25	25	50	50
11:30 AM	20	24	43	43
11:45 AM	25	19	44	44

File Ref:	1201317	1201318	Combined Totals	
Start Date:	Average	Average		
Direction:	NB	SB	NB/SB	Total
12:00 PM	24	24	48	48
12:15 PM	20	18	38	38
12:30 PM	27	21	48	48
12:45 PM	18	20	38	38
1:00 PM	18	24	41	41
1:15 PM	21	19	39	39
1:30 PM	23	21	43	43
1:45 PM	18	30	48	48
2:00 PM	22	22	44	44
2:15 PM	27	27	53	53
2:30 PM	27	22	49	49
2:45 PM	25	23	47	47
3:00 PM	28	28	55	55
3:15 PM	25	24	49	49
3:30 PM	29	21	50	50
3:45 PM	28	17	45	45
4:00 PM	41	21	61	61
4:15 PM	21	23	43	43
4:30 PM	32	28	60	60
4:45 PM	27	24	50	50
5:00 PM	24	26	50	50
5:15 PM	30	26	56	56
5:30 PM	14	19	33	33
5:45 PM	20	17	37	37
6:00 PM	13	20	33	33
6:15 PM	16	20	36	36
6:30 PM	21	15	35	35
6:45 PM	18	11	29	29
7:00 PM	17	13	30	30
7:15 PM	11	17	27	27
7:30 PM	8	9	17	17
7:45 PM	8	8	16	16
8:00 PM	9	9	18	18
8:15 PM	5	13	18	18
8:30 PM	5	11	15	15
8:45 PM	5	7	12	12
9:00 PM	7	3	10	10
9:15 PM	5	6	11	11
9:30 PM	5	5	10	10
9:45 PM	6	3	9	9
10:00 PM	6	3	9	9
10:15 PM	6	2	8	8
10:30 PM	2	2	4	4
10:45 PM	5	3	8	8
11:00 PM	2	2	3	3
11:15 PM	1	1	2	2
11:30 PM	0	1	1	1
11:45 PM	1	1	2	2
<b>Total:</b>	<b>1308</b>	<b>1247</b>	<b>2554</b>	<b>2554</b>
AM Peak Hr:	7:00 AM	11:15 AM	7:15 AM	7:15 AM
AM Peak Vol:	121	91	202	202
AM PHF:	0.8403	0.9100	0.9018	0.9018
PM Peak Hr:	3:15 PM	4:30 PM	4:30 PM	4:30 PM
PM Peak Vol:	121.5	102	216	216
PM PHF:	0.7500	0.9273	0.9000	0.9000

**TRAFFIC COUNT SUMMARY**

Site ID:	8	
Location 1:	MERIDIAN RD	
Location 2:	N of ELLIOT RD	
Latitude:	33.35148	33.35148
Longitude:	-111.58381	-111.58381

File Ref:	1201325	1201326	
Start Date:	Average	Average	<b>Combined Totals</b>

Direction:	NB	SB	NB/SB	Total
12:00 AM	3	1	4	4
12:15 AM	1	2	2	2
12:30 AM	1	2	3	3
12:45 AM	0	0	0	0
1:00 AM	1	1	1	1
1:15 AM	0	1	1	1
1:30 AM	1	1	2	2
1:45 AM	1	2	2	2
2:00 AM	1	1	2	2
2:15 AM	0	1	1	1
2:30 AM	0	1	1	1
2:45 AM	0	0	0	0
3:00 AM	0	1	1	1
3:15 AM	0	1	1	1
3:30 AM	1	3	3	3
3:45 AM	0	0	0	0
4:00 AM	0	2	2	2
4:15 AM	0	2	2	2
4:30 AM	0	2	2	2
4:45 AM	1	1	1	1
5:00 AM	1	5	6	6
5:15 AM	1	7	8	8
5:30 AM	0	7	7	7
5:45 AM	3	8	10	10
6:00 AM	3	8	11	11
6:15 AM	4	12	16	16
6:30 AM	4	14	18	18
6:45 AM	8	24	31	31
7:00 AM	9	20	29	29
7:15 AM	7	16	22	22
7:30 AM	6	18	24	24
7:45 AM	8	21	29	29
8:00 AM	13	19	32	32
8:15 AM	6	15	21	21
8:30 AM	4	6	10	10
8:45 AM	7	10	17	17
9:00 AM	5	8	13	13
9:15 AM	6	11	16	16
9:30 AM	7	7	14	14
9:45 AM	6	6	12	12
10:00 AM	4	6	10	10
10:15 AM	3	5	8	8
10:30 AM	8	4	12	12
10:45 AM	5	7	12	12
11:00 AM	5	6	11	11
11:15 AM	7	4	11	11
11:30 AM	7	5	11	11
11:45 AM	10	7	17	17

File Ref:	1201325	1201326	Combined Totals	
Start Date:	Average	Average		
Direction:	NB	SB	NB/SB	Total
12:00 PM	10	6	16	16
12:15 PM	9	6	14	14
12:30 PM	6	6	12	12
12:45 PM	8	5	13	13
1:00 PM	12	7	19	19
1:15 PM	4	6	10	10
1:30 PM	5	8	13	13
1:45 PM	6	8	14	14
2:00 PM	8	11	18	18
2:15 PM	9	8	17	17
2:30 PM	9	11	20	20
2:45 PM	12	9	21	21
3:00 PM	20	9	29	29
3:15 PM	16	12	28	28
3:30 PM	14	7	20	20
3:45 PM	8	10	18	18
4:00 PM	12	8	20	20
4:15 PM	16	7	23	23
4:30 PM	18	9	27	27
4:45 PM	16	10	25	25
5:00 PM	15	5	20	20
5:15 PM	13	12	24	24
5:30 PM	14	7	21	21
5:45 PM	16	8	23	23
6:00 PM	9	5	14	14
6:15 PM	15	5	20	20
6:30 PM	15	6	20	20
6:45 PM	16	7	23	23
7:00 PM	10	8	17	17
7:15 PM	10	6	16	16
7:30 PM	10	7	17	17
7:45 PM	9	5	13	13
8:00 PM	7	6	13	13
8:15 PM	13	3	16	16
8:30 PM	11	4	15	15
8:45 PM	8	5	13	13
9:00 PM	7	5	12	12
9:15 PM	9	4	13	13
9:30 PM	2	3	5	5
9:45 PM	4	4	8	8
10:00 PM	8	2	10	10
10:15 PM	5	1	6	6
10:30 PM	5	4	9	9
10:45 PM	4	2	5	5
11:00 PM	4	1	5	5
11:15 PM	3	2	5	5
11:30 PM	2	2	3	3
11:45 PM	3	2	4	4
<b>Total:</b>	<b>609</b>	<b>581</b>	<b>1190</b>	<b>1190</b>
AM Peak Hr:	11:30 AM	6:45 AM	6:45 AM	6:45 AM
AM Peak Vol:	34	76.5	106	106
AM PHF:	0.8947	0.8138	0.8548	0.8548
PM Peak Hr:	4:15 PM	2:30 PM	2:30 PM	2:30 PM
PM Peak Vol:	63	40.5	98	98
PM PHF:	0.9000	0.8438	0.8448	0.8448

**TRAFFIC COUNT SUMMARY**

Site ID: 9  
 Location 1: MERIDIAN RD  
 Location 2: Btwn ELLIOT RD & WARNER RD  
 Latitude: 33.34041 33.34041  
 Longitude: -111.58371 -111.58371

File Ref: 1201323 1201324  
 Start Date: Average Average

**Combined Totals**

Direction:	NB	SB	NB/SB	Total
12:00 AM	1	2	3	3
12:15 AM	1	0	1	1
12:30 AM	1	0	1	1
12:45 AM	1	2	2	2
1:00 AM	0	0	0	0
1:15 AM	0	0	0	0
1:30 AM	0	1	1	1
1:45 AM	0	0	0	0
2:00 AM	0	1	1	1
2:15 AM	0	0	0	0
2:30 AM	1	0	1	1
2:45 AM	0	1	1	1
3:00 AM	2	0	2	2
3:15 AM	0	1	1	1
3:30 AM	3	0	3	3
3:45 AM	1	0	1	1
4:00 AM	3	0	3	3
4:15 AM	3	0	3	3
4:30 AM	5	0	5	5
4:45 AM	6	1	7	7
5:00 AM	12	0	12	12
5:15 AM	14	1	14	14
5:30 AM	10	1	10	10
5:45 AM	8	3	11	11
6:00 AM	12	2	14	14
6:15 AM	15	3	17	17
6:30 AM	15	3	18	18
6:45 AM	19	7	26	26
7:00 AM	28	4	32	32
7:15 AM	13	3	16	16
7:30 AM	17	5	22	22
7:45 AM	23	9	32	32
8:00 AM	18	8	26	26
8:15 AM	11	4	15	15
8:30 AM	11	4	14	14
8:45 AM	8	7	14	14
9:00 AM	5	9	14	14
9:15 AM	6	3	9	9
9:30 AM	6	7	13	13
9:45 AM	11	5	16	16
10:00 AM	4	5	9	9
10:15 AM	7	3	10	10
10:30 AM	5	4	9	9
10:45 AM	8	7	15	15
11:00 AM	10	7	17	17
11:15 AM	7	6	13	13
11:30 AM	4	8	12	12
11:45 AM	7	8	15	15



File Ref:	1201323	1201324	<b>Combined Totals</b>	
Start Date:	Average	Average		
Direction:	<b>NB</b>	<b>SB</b>	<b>NB/SB</b>	<b>Total</b>
12:00 PM	7	11	18	18
12:15 PM	9	9	18	18
12:30 PM	7	8	15	15
12:45 PM	11	8	19	19
1:00 PM	6	6	12	12
1:15 PM	9	7	16	16
1:30 PM	5	6	11	11
1:45 PM	6	8	13	13
2:00 PM	8	7	15	15
2:15 PM	7	7	13	13
2:30 PM	9	9	17	17
2:45 PM	13	12	25	25
3:00 PM	15	21	36	36
3:15 PM	9	11	20	20
3:30 PM	9	14	23	23
3:45 PM	10	15	24	24
4:00 PM	10	14	24	24
4:15 PM	14	18	31	31
4:30 PM	15	17	32	32
4:45 PM	10	17	27	27
5:00 PM	11	16	27	27
5:15 PM	7	18	25	25
5:30 PM	7	16	23	23
5:45 PM	12	14	26	26
6:00 PM	5	13	18	18
6:15 PM	11	12	22	22
6:30 PM	5	14	19	19
6:45 PM	11	13	23	23
7:00 PM	9	12	21	21
7:15 PM	5	10	15	15
7:30 PM	8	9	16	16
7:45 PM	9	6	14	14
8:00 PM	4	14	18	18
8:15 PM	5	9	14	14
8:30 PM	4	9	13	13
8:45 PM	4	5	9	9
9:00 PM	2	7	9	9
9:15 PM	4	7	10	10
9:30 PM	2	5	6	6
9:45 PM	2	9	11	11
10:00 PM	3	2	5	5
10:15 PM	3	7	9	9
10:30 PM	3	5	8	8
10:45 PM	2	4	6	6
11:00 PM	1	2	3	3
11:15 PM	1	2	2	2
11:30 PM	1	3	4	4
11:45 PM	1	3	4	4
<b>Total:</b>	<b>651</b>	<b>595</b>	<b>1246</b>	<b>1246</b>
AM Peak Hr:	7:00 AM	11:30 AM	7:00 AM	7:00 AM
AM Peak Vol:	80	35.5	102	102
AM PHF:	0.7143	0.8068	0.7969	0.7969
PM Peak Hr:	4:15 PM	4:30 PM	4:15 PM	4:15 PM
PM Peak Vol:	49.5	67	115	115
PM PHF:	0.8250	0.9306	0.8984	0.8984

# **APPENDIX B**

## **EXCERPTS FROM 2009 QUALITY/LEVEL OF SERVICE HANDBOOK**

**Baker**

**Michael Baker Jr., Inc.**  
*Phoenix, Arizona*

2009

# QUALITY/LEVEL OF SERVICE



HANDBOOK

2009  
State of Florida  
Department of Transportation

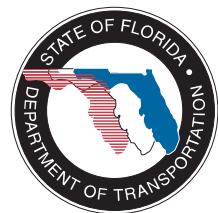

**TABLE 1**

**Generalized Annual Average Daily Volumes for Florida's Urbanized Areas<sup>1</sup>**

10/4/10

<b>STATE SIGNALIZED ARTERIALS</b>						<b>FREEWAYS</b>						
<b>Class I</b> (>0.00 to 1.99 signalized intersections per mile)						Lanes	B	C	D	E		
Lanes	Median	B	C	D	E	4	43,500	59,800	73,600	79,400		
2	Undivided	9,600	15,400	16,500	***	6	65,300	90,500	110,300	122,700		
4	Divided	29,300	35,500	36,700	***	8	87,000	120,100	146,500	166,000		
6	Divided	45,000	53,700	55,300	***	10	108,700	151,700	184,000	209,200		
8	Divided	60,800	71,800	73,800	***	12	149,300	202,100	238,600	252,500		
<b>Class II</b> (2.00 to 4.50 signalized intersections per mile)						<b>Freeway Adjustments</b>						
Lanes	Median	B	C	D	E	Auxiliary Lanes	Ramp Metering					
2	Undivided	**	10,500	15,200	16,200	+ 20,000	+ 5%					
4	Divided	**	25,000	33,200	35,100							
6	Divided	**	39,000	50,300	53,100							
8	Divided	**	53,100	67,300	70,900							
<b>Class III/IV</b> (more than 4.5 signalized intersections per mile)						<b>UNINTERRUPTED FLOW HIGHWAYS</b>						
Lanes	Median	B	C	D	E	Lanes	Median	B	C	D	E	
2	Undivided	**	5,100	11,900	14,900	2	Undivided	7,800	15,600	22,200	27,900	
4	Divided	**	12,600	28,200	31,900	4	Divided	34,300	49,600	64,300	72,800	
6	Divided	**	19,700	43,700	48,200	6	Divided	51,500	74,400	96,400	109,400	
8	Divided	**	27,000	59,500	64,700	<b>Uninterrupted Flow Highway Adjustments</b>						
						Lanes	Median	Exclusive left lanes	Adjustment factors			
						2	Divided	Yes	+5%			
						Multi	Undivided	Yes	-5%			
						Multi	Undivided	No	-25%			
<b>Non-State Signalized Roadway Adjustments</b> (Alter corresponding state volumes by the indicated percent.)						<b>BICYCLE MODE<sup>2</sup></b> (Multiply motorized vehicle volumes shown below by number of directional roadway lanes to determine two-way maximum service volumes.)						
Major City/County Roadways - 10%						Paved Shoulder/ Bicycle Lane						
Other Signalized Roadways - 35%						Coverage	B	C	D	E		
						0-49%	**	3,200	12,100	>12,100		
						50-84%	2,400	3,700	>3,700	***		
						85-100%	6,300	>6,300	***	***		
<b>State &amp; Non-State Signalized Roadway Adjustments</b> (Alter corresponding state volumes by the indicated percent.)						<b>PEDESTRIAN MODE<sup>2</sup></b> (Multiply motorized vehicle volumes shown below by number of directional roadway lanes to determine two-way maximum service volumes.)						
<b>Divided/Undivided &amp; Turn Lane Adjustments</b>						Sidewalk Coverage	B	C	D	E		
Lanes	Median	Exclusive Left Lanes	Exclusive Right Lanes	Adjustment Factors			0-49%	**	**	5,000	14,400	
2	Divided	Yes	No	+5%			50-84%	**	**	11,300	18,800	
2	Undivided	No	No	-20%			85-100%	**	11,400	18,800	>18,800	
Multi	Undivided	Yes	No	-5%			<b>BUS MODE (Scheduled Fixed Route)<sup>3</sup></b> (Buses in peak hour in peak direction)					
Multi	Undivided	No	No	-25%			Sidewalk Coverage	B	C	D	E	
-	-	-	Yes	+ 5%			0-84%	>5	≥4	≥3	≥2	
						85-100%	>4	≥3	≥2	≥1		
<b>One-Way Facility Adjustment</b> Multiply the corresponding two-directional volumes in this table by 0.6.												

<sup>1</sup> Values shown are presented as two-way annual average daily volumes for levels of service and are for the automobile/truck modes unless specifically stated. Although presented as daily volumes, they actually represent peak hour direction conditions with applicable K and D factors applied. This table does not constitute a standard and should be used only for general planning applications. The computer models from which this table is derived should be used for more specific planning applications. The table and deriving computer models should not be used for corridor or intersection design, where more refined techniques exist. Calculations are based on planning applications of the Highway Capacity Manual, Bicycle LOS Model, Pedestrian LOS Model and Transit Capacity and Quality of Service Manual, respectively for the automobile/truck, bicycle, pedestrian and bus modes.

<sup>2</sup> Level of service for the bicycle and pedestrian modes in this table is based on number of motorized vehicles, not number of bicyclists or pedestrians using the facility.

<sup>3</sup> Buses per hour shown are only for the peak hour in the single direction of the higher traffic flow.

\*\* Cannot be achieved using table input value defaults.

\*\*\* Not applicable for that level of service letter grade. For the automobile mode, volumes greater than level of service D become F because intersection capacities have been reached. For the bicycle mode, the level of service letter grade (including F) is not achievable because there is no maximum vehicle volume threshold using table input value defaults.

Source:

Florida Department of Transportation  
Systems Planning Office  
605 Suwannee Street, MS 19  
Tallahassee, FL 32399-0450

TABLE 1  
(continued)

Generalized **Annual Average Daily** Volumes for Florida's  
**Urbanized Areas**

9/4/09

INPUT VALUE ASSUMPTIONS	Uninterrupted Flow Facilities		Interrupted Flow Facilities									
	Freeways	Highways	State Arterials						Class II			
			Class I	Class II	Class III	Bicycle	Pedestrian	Bus				
<b>ROADWAY CHARACTERISTICS</b>												
Area type (l,o)	1	1	1	1	1	1	1	1	1	1	1	1
Number of through lanes	4-12	2	4-6	2	4-8	2	4-8	2	4-8	4	4	
Posted speed (mph)	65	50	50	45	50	45	45	35	35	45	45	
Free flow speed (mph)	70	55	55	50	55	50	50	40	40	50	50	
Aux, meter, or accel/decel $\geq 1500$ (n,y)	n											
Median (n, nr, r)		n	r	n	r	n	r	n	r	r	r	
Terrain (l,r)	1	1	1									
% no passing zone		80										
Exclusive left turn lanes / [impact](n, y)		[n]	y	y	y	y	y	y	y	y	y	
Exclusive right turn lanes (n, y)				n	n	n	n	n	n	n	n	
Paved shoulder/bicycle lane (n, y)										n, 50%,y	n	
Outside lane width										t	t	
Pavement condition										t		
Sidewalk (n, y)											n, 50%,y	n,y
Sidewalk/roadway separation (a, t, w)											t	
Sidewalk protective barrier (n, y)											n	
Obstacle to bus stop (n, y)												n
Facility length (mi)	4	5	5	2	2	2	2	2	2	2	2	2
Number of segments	4											
<b>TRAFFIC CHARACTERISTICS</b>												
Planning analysis hour factor (K)	0.092	0.094	0.094	0.097	0.097	0.097	0.097	0.097	0.097	0.097	0.097	
Directional distribution factor (D)	0.55	0.55	0.55	0.55	0.55	0.55	0.55	0.55	0.55	0.55	0.55	
Peak hour factor (PHF)	0.95	0.925	0.925	0.925	0.925	0.925	0.925	0.925	0.925	0.925	0.925	
Base saturation flow rate (pcphpl)		1700	2100	1950	1950	1950	1950	1950	1950	1950	1950	
Heavy vehicle percent	4.0	2.0	2.0	2.0	2.0	2.0	2.0	1.5	1.5	2.0	2.0	
Local adjustment factor	0.98	1.0	0.98									
% left turns				12	12	12	12	12	12	12	12	
% right turns				12	12	12	12	12	12	12	12	
Bus span of service												15
<b>CONTROL CHARACTERISTICS</b>												
Number of signals				2	2	6	6	10	10	6	6	
Arrival type (1-6)				3	3	4	4	4	4	4	4	
Signal type (a, s, p)				a	a	s	s	s	s	s	s	
Cycle length (C)				120	120	120	120	120	120	120	120	
Effective green ratio (g/C)				0.44	0.44	0.44	0.44	0.44	0.44	0.44	0.44	
<b>LEVEL OF SERVICE THRESHOLDS</b>												
Level of Service	Freeways	Highway Segments		State & Non-State Signalized Arterials			Bicycle	Pedestrian	Bus			
	Density	Two-Lane	Multilane	Class I	Class II	Class III	Score	Score	Buses per hr.			
B	$\leq 17$	$\geq 0.833$	$\leq 18$	$> 34$ mph	$> 28$ mph	$> 24$ mph	$\leq 2.5$	$\leq 2.5$	$\geq 4$			
C	$\leq 24$	$> 0.750$	$\leq 26$	$> 27$ mph	$> 22$ mph	$> 18$ mph	$\leq 3.5$	$\leq 3.5$	$\geq 3$			
D	$\leq 31$	$> 0.667$	$\leq 35$	$> 21$ mph	$> 17$ mph	$> 14$ mph	$\leq 4.5$	$\leq 4.5$	$\geq 2$			
E	$\leq 39$	$> 0.583$	$\leq 41$	$> 16$ mph	$> 13$ mph	$> 10$ mph	$\leq 5.5$	$\leq 5.5$	$\geq 1$			

% ffs = Percent free flow speed    ats = Average travel speed



# APPENDIX C

## EXISTING 2012 LOS REPORTS

















**Baker**

**Michael Baker Jr., Inc.**  
*Phoenix, Arizona*

# HCM Unsignalized Intersection Capacity Analysis - AM Peak Hour

## 1: McDowell Road & Meridian Road

9/26/2012

												
Movement	EBL	EBT	EBR	WBL	WBT	WBR	NBL	NBT	NBR	SBL	SBT	SBR
Lane Configurations												
Volume (veh/h)	0	0	0	1	0	1	0	3	1	0	2	0
Sign Control		Stop			Stop			Free			Free	
Grade		0%			0%			0%			0%	
Peak Hour Factor	0.92	0.92	0.92	0.92	0.92	0.92	0.92	0.92	0.92	0.92	0.92	0.92
Hourly flow rate (vph)	0	0	0	1	0	1	0	4	1	0	3	0
Pedestrians												
Lane Width (ft)												
Walking Speed (ft/s)												
Percent Blockage												
Right turn flare (veh)												
Median type								None			None	
Median storage (veh)												
Upstream signal (ft)												
pX, platoon unblocked												
vC, conflicting volume	8	8	3	7	7	5	3			5		
vC1, stage 1 conf vol												
vC2, stage 2 conf vol												
vCu, unblocked vol	8	8	3	7	7	5	3			5		
tC, single (s)	7.1	6.5	6.2	7.1	6.5	6.2	4.1			4.1		
tC, 2 stage (s)												
tF (s)	3.5	4.0	3.3	3.5	4.0	3.3	2.2			2.2		
p0 queue free %	100	100	100	100	100	100	100			100		
cM capacity (veh/h)	1009	887	1081	1012	888	1079	1620			1616		
<b>Direction, Lane #</b>	<b>EB 1</b>	<b>WB 1</b>	<b>NB 1</b>	<b>SB 1</b>								
Volume Total	0	3	5	3								
Volume Left	0	1	0	0								
Volume Right	0	1	1	0								
cSH	1700	1045	1620	1616								
Volume to Capacity	0.00	0.00	0.00	0.00								
Queue Length 95th (ft)	0	0	0	0								
Control Delay (s)	0.0	8.5	0.0	0.0								
Lane LOS	A	A										
Approach Delay (s)	0.0	8.5	0.0	0.0								
Approach LOS	A	A										
<b>Intersection Summary</b>												
Average Delay				2.1								
Intersection Capacity Utilization			13.3%		ICU Level of Service					A		
Analysis Period (min)			15									

# HCM Unsignalized Intersection Capacity Analysis - AM Peak Hour

## 5: McKellips Boulevard & Meridain Road

9/26/2012



Movement	WBL	WBR	NBT	NBR	SBL	SBT
Lane Configurations	Y		Y			Y
Volume (veh/h)	99	2	21	22	2	47
Sign Control	Stop		Free			Free
Grade	0%		0%			0%
Peak Hour Factor	0.92	0.92	0.92	0.92	0.92	0.92
Hourly flow rate (vph)	129	3	27	29	3	61
Pedestrians						
Lane Width (ft)						
Walking Speed (ft/s)						
Percent Blockage						
Right turn flare (veh)						
Median type	None			None		
Median storage (veh)						
Upstream signal (ft)						
pX, platoon unblocked						
vC, conflicting volume	108	42			56	
vC1, stage 1 conf vol						
vC2, stage 2 conf vol						
vCu, unblocked vol	108	42			56	
tC, single (s)	6.4	6.2			4.1	
tC, 2 stage (s)						
tF (s)	3.5	3.3			2.2	
p0 queue free %	85	100			100	
cM capacity (veh/h)	888	1029			1549	

















Direction, Lane #	WB 1	NB 1	SB 1
Volume Total	132	56	64
Volume Left	129	0	3
Volume Right	3	29	0
cSH	890	1700	1549
Volume to Capacity	0.15	0.03	0.00
Queue Length 95th (ft)	13	0	0
Control Delay (s)	9.7	0.0	0.3
Lane LOS	A		A
Approach Delay (s)	9.7	0.0	0.3
Approach LOS	A		

Intersection Summary			
Average Delay		5.2	
Intersection Capacity Utilization		18.3%	ICU Level of Service A
Analysis Period (min)		15	

# HCM Unsignalized Intersection Capacity Analysis - AM Peak Hour

## 7: Brown Road & Meridain Road

























9/26/2012

												
Movement	EBL	EBT	EBR	WBL	WBT	WBR	NBL	NBT	NBR	SBL	SBT	SBR
Lane Configurations												
Sign Control		Stop			Stop			Stop			Stop	
Volume (vph)	23	47	42	19	73	5	23	31	9	3	61	84
Peak Hour Factor	0.92	0.92	0.92	0.92	0.92	0.92	0.92	0.92	0.92	0.92	0.92	0.92
Hourly flow rate (vph)	30	61	55	25	95	7	30	40	12	4	80	110
Direction, Lane #	EB 1	WB 1	NB 1	SB 1								
Volume Total (vph)	146	127	82	193								
Volume Left (vph)	30	25	30	4								
Volume Right (vph)	55	7	12	110								
Hadj (s)	-0.15	0.04	0.02	-0.30								
Departure Headway (s)	4.6	4.8	4.8	4.4								
Degree Utilization, x	0.19	0.17	0.11	0.23								
Capacity (veh/h)	733	702	694	771								
Control Delay (s)	8.6	8.7	8.4	8.7								
Approach Delay (s)	8.6	8.7	8.4	8.7								
Approach LOS	A	A	A	A								
Intersection Summary												
Delay			8.6									
HCM Level of Service			A									
Intersection Capacity Utilization			34.7%	ICU Level of Service	A							
Analysis Period (min)			15									

# HCM Signalized Intersection Capacity Analysis - AM Peak Hour

## 11: University Drive & Meridain Road

9/26/2012



























												
Movement	EBL	EBT	EBR	WBL	WBT	WBR	NBL	NBT	NBR	SBL	SBT	SBR
Lane Configurations		 			 			 			 	
Volume (vph)	29	218	64	24	260	15	61	63	38	36	82	97
Ideal Flow (vphpl)	1900	1900	1900	1900	1900	1900	1900	1900	1900	1900	1900	1900
Total Lost time (s)	4.0	4.0		4.0	4.0		4.0	4.0		4.0	4.0	4.0
Lane Util. Factor	1.00	0.95		1.00	0.95		1.00	0.95		1.00	0.95	1.00
Flt	1.00	0.97		1.00	0.99		1.00	0.94		1.00	1.00	0.85
Flt Protected	0.95	1.00		0.95	1.00		0.95	1.00		0.95	1.00	1.00
Satd. Flow (prot)	1770	3419		1770	3510		1770	3338		1770	3539	1583
Flt Permitted	0.54	1.00		0.53	1.00		0.68	1.00		0.67	1.00	1.00
Satd. Flow (perm)	1001	3419		993	3510		1275	3338		1245	3539	1583
Peak-hour factor, PHF	0.92	0.92	0.92	0.92	0.92	0.92	0.92	0.92	0.92	0.92	0.92	0.92
Growth Factor (vph)	120%	120%	120%	120%	120%	120%	120%	120%	120%	120%	120%	120%
Adj. Flow (vph)	38	284	83	31	339	20	80	82	50	47	107	127
RTOR Reduction (vph)	0	50	0	0	11	0	0	30	0	0	0	76
Lane Group Flow (vph)	38	317	0	31	348	0	80	102	0	47	107	51
Turn Type	Perm			Perm			Perm			Perm		Perm
Protected Phases		4			8			2			6	
Permitted Phases	4			8			2			6		6
Actuated Green, G (s)	16.0	16.0		16.0	16.0		16.0	16.0		16.0	16.0	16.0
Effective Green, g (s)	16.0	16.0		16.0	16.0		16.0	16.0		16.0	16.0	16.0
Actuated g/C Ratio	0.40	0.40		0.40	0.40		0.40	0.40		0.40	0.40	0.40
Clearance Time (s)	4.0	4.0		4.0	4.0		4.0	4.0		4.0	4.0	4.0
Lane Grp Cap (vph)	400	1368		397	1404		510	1335		498	1416	633
v/s Ratio Prot		0.09			c0.10			0.03			0.03	
v/s Ratio Perm	0.04			0.03			c0.06			0.04		0.03
v/c Ratio	0.10	0.23		0.08	0.25		0.16	0.08		0.09	0.08	0.08
Uniform Delay, d1	7.5	7.9		7.4	8.0		7.7	7.4		7.5	7.4	7.4
Progression Factor	1.00	1.00		1.00	1.00		1.00	1.00		1.00	1.00	1.00
Incremental Delay, d2	0.5	0.4		0.4	0.4		0.7	0.1		0.4	0.1	0.2
Delay (s)	8.0	8.3		7.8	8.4		8.3	7.5		7.9	7.5	7.7
Level of Service	A	A		A	A		A	A		A	A	A
Approach Delay (s)		8.3			8.4			7.8			7.7	
Approach LOS		A			A			A			A	
<b>Intersection Summary</b>												
HCM Average Control Delay			8.1			HCM Level of Service			A			
HCM Volume to Capacity ratio			0.20									
Actuated Cycle Length (s)			40.0			Sum of lost time (s)		8.0				
Intersection Capacity Utilization			33.7%			ICU Level of Service			A			
Analysis Period (min)			15									
c Critical Lane Group												



# HCM Signalized Intersection Capacity Analysis - AM Peak Hour

























## 17: Apache Trail & Meridain Road

9/26/2012

												
Movement	EBL	EBT	EBR	WBL	WBT	WBR	NBL	NBT	NBR	SBL	SBT	SBR
Lane Configurations		 			 			 			 	
Volume (vph)	79	281	28	45	312	55	52	121	61	77	74	50
Ideal Flow (vphpl)	1900	1900	1900	1900	1900	1900	1900	1900	1900	1900	1900	1900
Total Lost time (s)	4.0	4.0		4.0	4.0	4.0	4.0	4.0		4.0	4.0	
Lane Util. Factor	1.00	0.91		1.00	0.91	1.00	1.00	0.95		1.00	0.95	
Fr <sub>t</sub>	1.00	0.99		1.00	1.00	0.85	1.00	0.95		1.00	0.94	
Fl <sub>t</sub> Protected	0.95	1.00		0.95	1.00	1.00	0.95	1.00		0.95	1.00	
Satd. Flow (prot)	1770	5015		1770	5085	1583	1770	3361		1770	3326	
Fl <sub>t</sub> Permitted	0.50	1.00		0.51	1.00	1.00	0.65	1.00		0.60	1.00	
Satd. Flow (perm)	939	5015		942	5085	1583	1210	3361		1125	3326	
Peak-hour factor, PHF	0.92	0.92	0.92	0.92	0.92	0.92	0.92	0.92	0.92	0.92	0.92	0.92
Growth Factor (vph)	120%	120%	120%	120%	120%	120%	120%	120%	120%	120%	120%	120%
Adj. Flow (vph)	103	367	37	59	407	72	68	158	80	100	97	65
RTOR Reduction (vph)	0	24	0	0	0	49	0	51	0	0	42	0
Lane Group Flow (vph)	103	380	0	59	407	23	68	187	0	100	120	0
Turn Type	Perm			Perm			Perm	pm+pt		pm+pt		
Protected Phases		4			8		5	2		1	6	
Permitted Phases	4			8		8	2			6		
Actuated Green, G (s)	16.0	16.0		16.0	16.0	16.0	22.0	18.0		22.0	18.0	
Effective Green, g (s)	16.0	16.0		16.0	16.0	16.0	22.0	18.0		22.0	18.0	
Actuated g/C Ratio	0.32	0.32		0.32	0.32	0.32	0.44	0.36		0.44	0.36	
Clearance Time (s)	4.0	4.0		4.0	4.0	4.0	4.0	4.0		4.0	4.0	
Lane Grp Cap (vph)	300	1605		301	1627	507	577	1210		547	1197	
v/s Ratio Prot		0.08			0.08		0.01	0.06		c0.01	0.04	
v/s Ratio Perm	c0.11			0.06		0.01	0.04			c0.07		
v/c Ratio	0.34	0.24		0.20	0.25	0.05	0.12	0.15		0.18	0.10	
Uniform Delay, d <sub>1</sub>	13.0	12.5		12.3	12.6	11.7	8.2	10.8		8.3	10.6	
Progression Factor	1.00	1.00		1.00	1.00	1.00	1.00	1.00		1.00	1.00	
Incremental Delay, d <sub>2</sub>	3.1	0.3		1.5	0.4	0.2	0.4	0.3		0.7	0.2	
Delay (s)	16.1	12.9		13.8	12.9	11.9	8.6	11.1		9.0	10.8	
Level of Service	B	B		B	B	B	A	B		A	B	
Approach Delay (s)		13.5			12.9			10.5			10.1	
Approach LOS		B			B			B			B	
<b>Intersection Summary</b>												
HCM Average Control Delay			12.2				HCM Level of Service			B		
HCM Volume to Capacity ratio			0.25									
Actuated Cycle Length (s)			50.0				Sum of lost time (s)			12.0		
Intersection Capacity Utilization			37.3%				ICU Level of Service			A		
Analysis Period (min)			15									
c Critical Lane Group												

















HCM Signalized Intersection Capacity Analysis - AM Peak Hour  
 22: Broadway Avenue & Meridain Road

9/26/2012

												
Movement	EBL	EBT	EBR	WBL	WBT	WBR	NBL	NBT	NBR	SBL	SBT	SBR
Lane Configurations		 			 			 			 	
Volume (vph)	43	171	22	34	218	40	19	112	41	23	89	22
Ideal Flow (vphpl)	1900	1900	1900	1900	1900	1900	1900	1900	1900	1900	1900	1900
Total Lost time (s)	4.0	4.0		4.0	4.0		4.0	4.0		4.0	4.0	
Lane Util. Factor	1.00	0.95		1.00	0.95		1.00	0.95		1.00	0.95	
Flt	1.00	0.98		1.00	0.98		1.00	0.96		1.00	0.97	
Flt Protected	0.95	1.00		0.95	1.00		0.95	1.00		0.95	1.00	
Satd. Flow (prot)	1770	3478		1770	3457		1770	3398		1770	3433	
Flt Permitted	0.55	1.00		0.60	1.00		0.66	1.00		0.63	1.00	
Satd. Flow (perm)	1023	3478		1110	3457		1229	3398		1167	3433	
Peak-hour factor, PHF	0.92	0.92	0.92	0.92	0.92	0.92	0.92	0.92	0.92	0.92	0.92	0.92
Growth Factor (vph)	120%	120%	120%	120%	120%	120%	120%	120%	120%	120%	120%	120%
Adj. Flow (vph)	56	223	29	44	284	52	25	146	53	30	116	29
RTOR Reduction (vph)	0	17	0	0	31	0	0	32	0	0	17	0
Lane Group Flow (vph)	56	235	0	44	305	0	25	167	0	30	128	0
Turn Type	Perm			Perm			Perm			Perm		
Protected Phases		4			8			2			6	
Permitted Phases	4			8			2			6		
Actuated Green, G (s)	16.0	16.0		16.0	16.0		16.0	16.0		16.0	16.0	
Effective Green, g (s)	16.0	16.0		16.0	16.0		16.0	16.0		16.0	16.0	
Actuated g/C Ratio	0.40	0.40		0.40	0.40		0.40	0.40		0.40	0.40	
Clearance Time (s)	4.0	4.0		4.0	4.0		4.0	4.0		4.0	4.0	
Lane Grp Cap (vph)	409	1391		444	1383		492	1359		467	1373	
v/s Ratio Prot		0.07			c0.09			c0.05			0.04	
v/s Ratio Perm	0.05			0.04			0.02			0.03		
v/c Ratio	0.14	0.17		0.10	0.22		0.05	0.12		0.06	0.09	
Uniform Delay, d1	7.6	7.7		7.5	7.9		7.3	7.6		7.4	7.5	
Progression Factor	1.00	1.00		1.00	1.00		1.00	1.00		1.00	1.00	
Incremental Delay, d2	0.7	0.3		0.4	0.4		0.2	0.2		0.3	0.1	
Delay (s)	8.3	8.0		7.9	8.3		7.5	7.8		7.7	7.6	
Level of Service	A	A		A	A		A	A		A	A	
Approach Delay (s)		8.0			8.2			7.7			7.6	
Approach LOS		A			A			A			A	
<b>Intersection Summary</b>												
HCM Average Control Delay			8.0			HCM Level of Service				A		
HCM Volume to Capacity ratio			0.17									
Actuated Cycle Length (s)			40.0			Sum of lost time (s)			8.0			
Intersection Capacity Utilization			34.0%			ICU Level of Service				A		
Analysis Period (min)			15									
c Critical Lane Group												

HCM Unsignalized Intersection Capacity Analysis - AM Peak Hour  
 27: Southern Avenue & Meridain Road

9/26/2012

												
Movement	EBL	EBT	EBR	WBL	WBT	WBR	NBL	NBT	NBR	SBL	SBT	SBR
Lane Configurations												
Sign Control		Stop			Stop			Stop			Stop	
Volume (vph)	61	99	9	22	204	40	17	80	14	38	55	130
Peak Hour Factor	0.92	0.92	0.92	0.92	0.92	0.92	0.92	0.92	0.92	0.92	0.92	0.92
Hourly flow rate (vph)	80	129	12	29	266	52	22	104	18	50	72	170
Direction, Lane #	EB 1	EB 2	WB 1	NB 1	SB 1							
Volume Total (vph)	209	12	347	145	291							
Volume Left (vph)	80	0	29	22	50							
Volume Right (vph)	0	12	52	18	170							
Hadj (s)	0.22	-0.67	-0.04	-0.01	-0.28							
Departure Headway (s)	6.6	5.7	5.7	6.2	5.6							
Degree Utilization, x	0.38	0.02	0.55	0.25	0.45							
Capacity (veh/h)	502	575	593	505	587							
Control Delay (s)	12.4	7.6	15.5	11.2	13.2							
Approach Delay (s)	12.1		15.5	11.2	13.2							
Approach LOS	B		C	B	B							
Intersection Summary												
Delay			13.5									
HCM Level of Service			B									
Intersection Capacity Utilization			57.8%	ICU Level of Service	B							
Analysis Period (min)			15									

# HCM Unsignalized Intersection Capacity Analysis - AM Peak Hour

## 31: Baseline Road & Meridian Road

9/26/2012

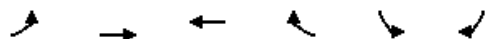

Movement	EBL	EBT	WBT	WBR	SBL	SBR
Lane Configurations	↶	↷	↷		↶	↷
Volume (veh/h)	61	129	319	58	30	49
Sign Control		Free	Free		Stop	
Grade		0%	0%		0%	
Peak Hour Factor	0.92	0.92	0.92	0.92	0.92	0.92
Hourly flow rate (vph)	80	168	416	76	39	64
Pedestrians						
Lane Width (ft)						
Walking Speed (ft/s)						
Percent Blockage						
Right turn flare (veh)						5
Median type		TWLTL	TWLTL			
Median storage (veh)		2	2			
Upstream signal (ft)						
pX, platoon unblocked						
vC, conflicting volume	492				781	454
vC1, stage 1 conf vol					454	
vC2, stage 2 conf vol					327	
vCu, unblocked vol	492				781	454
tC, single (s)	4.1				6.4	6.2
tC, 2 stage (s)					5.4	
tF (s)	2.2				3.5	3.3
p0 queue free %	93				93	89
cM capacity (veh/h)	1072				537	606

Direction, Lane #	EB 1	EB 2	WB 1	SB 1
Volume Total	80	168	492	103
Volume Left	80	0	0	39
Volume Right	0	0	76	64
cSH	1072	1700	1700	977
Volume to Capacity	0.07	0.10	0.29	0.11
Queue Length 95th (ft)	6	0	0	9
Control Delay (s)	8.6	0.0	0.0	11.9
Lane LOS	A			B
Approach Delay (s)	2.8		0.0	11.9
Approach LOS				B

Intersection Summary			
Average Delay		2.3	
Intersection Capacity Utilization		41.8%	ICU Level of Service A
Analysis Period (min)		15	

# HCM Unsignalized Intersection Capacity Analysis - AM Peak Hour

## 35: Elliot Road & Meridian Road

9/26/2012











Movement	EBL	EBR	NBL	NBT	SBT	SBR
Lane Configurations						
Volume (veh/h)	23	24	120	8	12	58
Sign Control	Stop			Free	Free	
Grade	0%			0%	0%	
Peak Hour Factor	0.92	0.92	0.92	0.92	0.92	0.92
Hourly flow rate (vph)	30	31	157	10	16	76
Pedestrians						
Lane Width (ft)						
Walking Speed (ft/s)						
Percent Blockage						
Right turn flare (veh)						
Median type						
TWLTL TWLTL						
Median storage (veh)						
2 2						
Upstream signal (ft)						
pX, platoon unblocked						
vC, conflicting volume	377	53	91			
vC1, stage 1 conf vol	53					
vC2, stage 2 conf vol	323					
vCu, unblocked vol	377	53	91			
tC, single (s)	6.4	6.2	4.1			
tC, 2 stage (s)	5.4					
tF (s)	3.5	3.3	2.2			
p0 queue free %	95	97	90			
cM capacity (veh/h)	637	1014	1504			
<b>Direction, Lane #</b>						
	EB 1	EB 2	NB 1	NB 2	SB 1	
Volume Total	30	31	157	10	91	
Volume Left	30	0	157	0	0	
Volume Right	0	31	0	0	76	
cSH	637	1014	1504	1700	1700	
Volume to Capacity	0.05	0.03	0.10	0.01	0.05	
Queue Length 95th (ft)	4	2	9	0	0	
Control Delay (s)	10.9	8.7	7.7	0.0	0.0	
Lane LOS	B	A	A			
Approach Delay (s)	9.8		7.2		0.0	
Approach LOS	A					
<b>Intersection Summary</b>						
Average Delay			5.6			
Intersection Capacity Utilization			24.6%	ICU Level of Service		A
Analysis Period (min)			15			



# HCM Unsignalized Intersection Capacity Analysis - AM Peak Hour

## 37: Warner Road & Meridian Road

















9/26/2012

						
Movement	EBL	EBR	NBL	NBT	SBT	SBR
Lane Configurations						
Volume (veh/h)	5	8	8	31	8	6
Sign Control	Stop			Free	Free	
Grade	0%			0%	0%	
Peak Hour Factor	0.92	0.92	0.92	0.92	0.92	0.92
Hourly flow rate (vph)	7	10	10	40	10	8
Pedestrians						
Lane Width (ft)						
Walking Speed (ft/s)						
Percent Blockage						
Right turn flare (veh)						
Median type				None	TWLTL	
Median storage (veh)					2	
Upstream signal (ft)						
pX, platoon unblocked						
vC, conflicting volume	76	14	18			
vC1, stage 1 conf vol	14					
vC2, stage 2 conf vol	61					
vCu, unblocked vol	76	14	18			
tC, single (s)	6.4	6.2	4.1			
tC, 2 stage (s)	5.4					
tF (s)	3.5	3.3	2.2			
p0 queue free %	99	99	99			
cM capacity (veh/h)	929	1065	1598			
Direction, Lane #	EB 1	NB 1	SB 1			
Volume Total	17	51	18			
Volume Left	7	10	0			
Volume Right	10	0	8			
cSH	1009	1598	1700			
Volume to Capacity	0.02	0.01	0.01			
Queue Length 95th (ft)	1	0	0			
Control Delay (s)	8.6	1.5	0.0			
Lane LOS	A	A				
Approach Delay (s)	8.6	1.5	0.0			
Approach LOS	A					
Intersection Summary						
Average Delay			2.6			
Intersection Capacity Utilization			19.2%	ICU Level of Service	A	
Analysis Period (min)			15			

# HCM Unsignalized Intersection Capacity Analysis - PM Peak Hour

## 1: McDowell Road & Meridian

9/26/2012

												
Movement	EBL	EBT	EBR	WBL	WBT	WBR	NBL	NBT	NBR	SBL	SBT	SBR
Lane Configurations												
Volume (veh/h)	0	0	0	0	0	0	1	10	0	0	2	0
Sign Control		Stop			Stop			Free			Free	
Grade		0%			0%			0%			0%	
Peak Hour Factor	0.90	0.90	0.90	0.90	0.90	0.90	0.90	0.90	0.90	0.90	0.90	0.90
Hourly flow rate (vph)	0	0	0	0	0	0	1	13	0	0	3	0
Pedestrians												
Lane Width (ft)												
Walking Speed (ft/s)												
Percent Blockage												
Right turn flare (veh)												
Median type								None			None	
Median storage (veh)												
Upstream signal (ft)												
pX, platoon unblocked												
vC, conflicting volume	19	19	3	19	19	13	3			13		
vC1, stage 1 conf vol												
vC2, stage 2 conf vol												
vCu, unblocked vol	19	19	3	19	19	13	3			13		
tC, single (s)	7.1	6.5	6.2	7.1	6.5	6.2	4.1			4.1		
tC, 2 stage (s)												
tF (s)	3.5	4.0	3.3	3.5	4.0	3.3	2.2			2.2		
p0 queue free %	100	100	100	100	100	100	100			100		
cM capacity (veh/h)	995	875	1081	995	875	1067	1619			1605		
<b>Direction, Lane #</b>	<b>EB 1</b>	<b>WB 1</b>	<b>NB 1</b>	<b>SB 1</b>								
Volume Total	0	0	15	3								
Volume Left	0	0	1	0								
Volume Right	0	0	0	0								
cSH	1700	1700	1619	1605								
Volume to Capacity	0.00	0.00	0.00	0.00								
Queue Length 95th (ft)	0	0	0	0								
Control Delay (s)	0.0	0.0	0.7	0.0								
Lane LOS	A	A	A									
Approach Delay (s)	0.0	0.0	0.7	0.0								
Approach LOS	A	A										
<b>Intersection Summary</b>												
Average Delay			0.6									
Intersection Capacity Utilization			6.7%		ICU Level of Service					A		
Analysis Period (min)			15									

# HCM Unsignalized Intersection Capacity Analysis - PM Peak Hour

## 5: McKellips Boulevard & Meridain Road

9/26/2012



















Movement	WBL	WBR	NBT	NBR	SBL	SBT
Lane Configurations	Y		T			T
Volume (veh/h)	46	3	59	67	2	27
Sign Control	Stop		Free			Free
Grade	0%		0%			0%
Peak Hour Factor	0.90	0.90	0.90	0.90	0.90	0.90
Hourly flow rate (vph)	61	4	79	89	3	36
Pedestrians						
Lane Width (ft)						
Walking Speed (ft/s)						
Percent Blockage						
Right turn flare (veh)						
Median type	None			None		
Median storage (veh)						
Upstream signal (ft)						
pX, platoon unblocked						
vC, conflicting volume	165	123			168	
vC1, stage 1 conf vol						
vC2, stage 2 conf vol						
vCu, unblocked vol	165	123			168	
tC, single (s)	6.4	6.2			4.1	
tC, 2 stage (s)						
tF (s)	3.5	3.3			2.2	
p0 queue free %	93	100			100	
cM capacity (veh/h)	824	928			1410	
Direction, Lane #	WB 1	NB 1	SB 1			
Volume Total	65	168	39			
Volume Left	61	0	3			
Volume Right	4	89	0			
cSH	830	1700	1410			
Volume to Capacity	0.08	0.10	0.00			
Queue Length 95th (ft)	6	0	0			
Control Delay (s)	9.7	0.0	0.5			
Lane LOS	A		A			
Approach Delay (s)	9.7	0.0	0.5			
Approach LOS	A					
Intersection Summary						
Average Delay			2.4			
Intersection Capacity Utilization			18.6%	ICU Level of Service	A	
Analysis Period (min)			15			

# HCM Unsignalized Intersection Capacity Analysis - PM Peak Hour

## 7: Brown Road & Meridain Road

























9/26/2012

												
Movement	EBL	EBT	EBR	WBL	WBT	WBR	NBL	NBT	NBR	SBL	SBT	SBR
Lane Configurations												
Sign Control		Stop			Stop			Stop			Stop	
Volume (vph)	53	111	53	14	56	4	22	65	12	4	42	28
Peak Hour Factor	0.90	0.90	0.90	0.90	0.90	0.90	0.90	0.90	0.90	0.90	0.90	0.90
Hourly flow rate (vph)	71	148	71	19	75	5	29	87	16	5	56	37
Direction, Lane #	EB 1	WB 1	NB 1	SB 1								
Volume Total (vph)	289	99	132	99								
Volume Left (vph)	71	19	29	5								
Volume Right (vph)	71	5	16	37								
Hadj (s)	-0.06	0.04	0.01	-0.18								
Departure Headway (s)	4.6	4.9	5.0	4.8								
Degree Utilization, x	0.37	0.13	0.18	0.13								
Capacity (veh/h)	749	684	666	674								
Control Delay (s)	10.2	8.6	9.1	8.6								
Approach Delay (s)	10.2	8.6	9.1	8.6								
Approach LOS	B	A	A	A								
Intersection Summary												
Delay			9.4									
HCM Level of Service			A									
Intersection Capacity Utilization			40.8%	ICU Level of Service	A							
Analysis Period (min)			15									

# HCM Signalized Intersection Capacity Analysis - PM Peak Hour

## 11: University Drive & Meridain Road

9/26/2012



























												
Movement	EBL	EBT	EBR	WBL	WBT	WBR	NBL	NBT	NBR	SBL	SBT	SBR
Lane Configurations		 			 			 			 	
Volume (vph)	62	384	96	42	236	26	76	120	60	40	93	52
Ideal Flow (vphpl)	1900	1900	1900	1900	1900	1900	1900	1900	1900	1900	1900	1900
Total Lost time (s)	4.0	4.0		4.0	4.0		4.0	4.0		4.0	4.0	4.0
Lane Util. Factor	1.00	0.95		1.00	0.95		1.00	0.95		1.00	0.95	1.00
Flt	1.00	0.97		1.00	0.98		1.00	0.95		1.00	1.00	0.85
Flt Protected	0.95	1.00		0.95	1.00		0.95	1.00		0.95	1.00	1.00
Satd. Flow (prot)	1770	3433		1770	3486		1770	3362		1770	3539	1583
Flt Permitted	0.54	1.00		0.37	1.00		0.67	1.00		0.60	1.00	1.00
Satd. Flow (perm)	1010	3433		689	3486		1254	3362		1122	3539	1583
Peak-hour factor, PHF	0.90	0.90	0.90	0.90	0.90	0.90	0.90	0.90	0.90	0.90	0.90	0.90
Growth Factor (vph)	120%	120%	120%	120%	120%	120%	120%	120%	120%	120%	120%	120%
Adj. Flow (vph)	83	512	128	56	315	35	101	160	80	53	124	69
RTOR Reduction (vph)	0	55	0	0	21	0	0	48	0	0	0	41
Lane Group Flow (vph)	83	585	0	56	329	0	101	192	0	53	124	28
Turn Type	Perm			Perm			Perm			Perm		Perm
Protected Phases		4			8			2			6	
Permitted Phases	4			8			2			6		6
Actuated Green, G (s)	16.0	16.0		16.0	16.0		16.0	16.0		16.0	16.0	16.0
Effective Green, g (s)	16.0	16.0		16.0	16.0		16.0	16.0		16.0	16.0	16.0
Actuated g/C Ratio	0.40	0.40		0.40	0.40		0.40	0.40		0.40	0.40	0.40
Clearance Time (s)	4.0	4.0		4.0	4.0		4.0	4.0		4.0	4.0	4.0
Lane Grp Cap (vph)	404	1373		276	1394		502	1345		449	1416	633
v/s Ratio Prot		c0.17			0.09			0.06			0.04	
v/s Ratio Perm	0.08			0.08			c0.08			0.05		0.02
v/c Ratio	0.21	0.43		0.20	0.24		0.20	0.14		0.12	0.09	0.04
Uniform Delay, d1	7.8	8.7		7.8	8.0		7.8	7.6		7.6	7.5	7.3
Progression Factor	1.00	1.00		1.00	1.00		1.00	1.00		1.50	1.46	2.41
Incremental Delay, d2	1.1	1.0		1.7	0.4		0.9	0.2		0.5	0.1	0.1
Delay (s)	9.0	9.6		9.5	8.3		8.7	7.9		11.8	11.0	17.8
Level of Service	A	A		A	A		A	A		B	B	B
Approach Delay (s)		9.6			8.5			8.1			13.1	
Approach LOS		A			A			A			B	
<b>Intersection Summary</b>												
HCM Average Control Delay			9.5			HCM Level of Service			A			
HCM Volume to Capacity ratio			0.31									
Actuated Cycle Length (s)			40.0			Sum of lost time (s)			8.0			
Intersection Capacity Utilization			42.7%			ICU Level of Service			A			
Analysis Period (min)			15									
c Critical Lane Group												



# HCM Signalized Intersection Capacity Analysis - PM Peak Hour

## 17: Apache Trail & Meridain Road

























9/26/2012

												
Movement	EBL	EBT	EBR	WBL	WBT	WBR	NBL	NBT	NBR	SBL	SBT	SBR
Lane Configurations		 			 			 			 	
Volume (vph)	101	479	56	60	391	86	55	127	63	122	108	60
Ideal Flow (vphpl)	1900	1900	1900	1900	1900	1900	1900	1900	1900	1900	1900	1900
Total Lost time (s)	4.0	4.0		4.0	4.0	4.0	4.0	4.0		4.0	4.0	
Lane Util. Factor	1.00	0.91		1.00	0.91	1.00	1.00	0.95		1.00	0.95	
Fr <sub>t</sub>	1.00	0.98		1.00	1.00	0.85	1.00	0.95		1.00	0.95	
Fl <sub>t</sub> Protected	0.95	1.00		0.95	1.00	1.00	0.95	1.00		0.95	1.00	
Satd. Flow (prot)	1770	5005		1770	5085	1583	1770	3363		1770	3350	
Fl <sub>t</sub> Permitted	0.45	1.00		0.34	1.00	1.00	0.61	1.00		0.60	1.00	
Satd. Flow (perm)	836	5005		625	5085	1583	1140	3363		1108	3350	
Peak-hour factor, PHF	0.90	0.90	0.90	0.90	0.90	0.90	0.90	0.90	0.90	0.90	0.90	0.90
Growth Factor (vph)	120%	120%	120%	120%	120%	120%	120%	120%	120%	120%	120%	120%
Adj. Flow (vph)	135	639	75	80	521	115	73	169	84	163	144	80
RTOR Reduction (vph)	0	30	0	0	0	77	0	56	0	0	53	0
Lane Group Flow (vph)	135	684	0	80	521	38	73	197	0	163	171	0
Turn Type	Perm			Perm			Perm	pm+pt		pm+pt		
Protected Phases		4			8		5	2		1	6	
Permitted Phases	4			8		8	2			6		
Actuated Green, G (s)	16.0	16.0		16.0	16.0	16.0	20.0	16.0		20.0	16.0	
Effective Green, g (s)	16.0	16.0		16.0	16.0	16.0	20.0	16.0		20.0	16.0	
Actuated g/C Ratio	0.33	0.33		0.33	0.33	0.33	0.42	0.33		0.42	0.33	
Clearance Time (s)	4.0	4.0		4.0	4.0	4.0	4.0	4.0		4.0	4.0	
Lane Grp Cap (vph)	279	1668		208	1695	528	528	1121		517	1117	
v/s Ratio Prot		0.14			0.10		0.01	0.06		c0.03	0.05	
v/s Ratio Perm	c0.16			0.13		0.02	0.05			c0.11		
v/c Ratio	0.48	0.41		0.38	0.31	0.07	0.14	0.18		0.32	0.15	
Uniform Delay, d <sub>1</sub>	12.7	12.4		12.2	11.9	10.9	8.5	11.3		9.0	11.2	
Progression Factor	1.00	1.00		1.00	1.00	1.00	1.00	1.00		1.00	1.00	
Incremental Delay, d <sub>2</sub>	5.9	0.7		5.3	0.5	0.3	0.5	0.3		1.6	0.3	
Delay (s)	18.6	13.1		17.5	12.4	11.2	9.1	11.7		10.6	11.5	
Level of Service	B	B		B	B	B	A	B		B	B	
Approach Delay (s)		14.0			12.7			11.1			11.1	
Approach LOS		B			B			B			B	
<b>Intersection Summary</b>												
HCM Average Control Delay			12.7				HCM Level of Service				B	
HCM Volume to Capacity ratio			0.39									
Actuated Cycle Length (s)			48.0				Sum of lost time (s)			12.0		
Intersection Capacity Utilization			44.7%				ICU Level of Service			A		
Analysis Period (min)			15									
c Critical Lane Group												

# HCM Signalized Intersection Capacity Analysis - PM Peak Hour

## 22: Broadway Avenue & Meridain Road



















9/26/2012

												
Movement	EBL	EBT	EBR	WBL	WBT	WBR	NBL	NBT	NBR	SBL	SBT	SBR
Lane Configurations		 			 			 			 	
Volume (vph)	59	285	23	27	185	49	19	126	56	50	117	52
Ideal Flow (vphpl)	1900	1900	1900	1900	1900	1900	1900	1900	1900	1900	1900	1900
Total Lost time (s)	4.0	4.0		4.0	4.0		4.0	4.0		4.0	4.0	
Lane Util. Factor	1.00	0.95		1.00	0.95		1.00	0.95		1.00	0.95	
Fr <sub>t</sub>	1.00	0.99		1.00	0.97		1.00	0.95		1.00	0.95	
Fl <sub>t</sub> Protected	0.95	1.00		0.95	1.00		0.95	1.00		0.95	1.00	
Satd. Flow (prot)	1770	3499		1770	3429		1770	3375		1770	3376	
Fl <sub>t</sub> Permitted	0.56	1.00		0.51	1.00		0.61	1.00		0.60	1.00	
Satd. Flow (perm)	1047	3499		952	3429		1139	3375		1119	3376	
Peak-hour factor, PHF	0.90	0.90	0.90	0.90	0.90	0.90	0.90	0.90	0.90	0.90	0.90	0.90
Growth Factor (vph)	120%	120%	120%	120%	120%	120%	120%	120%	120%	120%	120%	120%
Adj. Flow (vph)	79	380	31	36	247	65	25	168	75	67	156	69
RTOR Reduction (vph)	0	15	0	0	39	0	0	45	0	0	41	0
Lane Group Flow (vph)	79	396	0	36	273	0	25	198	0	67	184	0
Turn Type	Perm			Perm			Perm			Perm		
Protected Phases		4			8			2			6	
Permitted Phases	4			8			2			6		
Actuated Green, G (s)	16.0	16.0		16.0	16.0		16.0	16.0		16.0	16.0	
Effective Green, g (s)	16.0	16.0		16.0	16.0		16.0	16.0		16.0	16.0	
Actuated g/C Ratio	0.40	0.40		0.40	0.40		0.40	0.40		0.40	0.40	
Clearance Time (s)	4.0	4.0		4.0	4.0		4.0	4.0		4.0	4.0	
Lane Grp Cap (vph)	419	1400		381	1372		456	1350		448	1350	
v/s Ratio Prot		c0.11			0.08			0.06			0.05	
v/s Ratio Perm	0.08			0.04			0.02			c0.06		
v/c Ratio	0.19	0.28		0.09	0.20		0.05	0.15		0.15	0.14	
Uniform Delay, d <sub>1</sub>	7.8	8.1		7.5	7.8		7.4	7.6		7.7	7.6	
Progression Factor	1.00	1.00		1.00	1.00		1.00	1.00		1.00	1.00	
Incremental Delay, d <sub>2</sub>	1.0	0.5		0.5	0.3		0.2	0.2		0.7	0.2	
Delay (s)	8.8	8.6		8.0	8.1		7.6	7.9		8.4	7.8	
Level of Service	A	A		A	A		A	A		A	A	
Approach Delay (s)		8.7			8.1			7.9			7.9	
Approach LOS		A			A			A			A	
<b>Intersection Summary</b>												
HCM Average Control Delay			8.2			HCM Level of Service			A			
HCM Volume to Capacity ratio			0.22									
Actuated Cycle Length (s)			40.0			Sum of lost time (s)		8.0				
Intersection Capacity Utilization			36.7%			ICU Level of Service			A			
Analysis Period (min)			15									
c Critical Lane Group												

# HCM Unsignalized Intersection Capacity Analysis - PM Peak Hour

## 27: Southern Avenue & Meridain Road

9/26/2012

												
Movement	EBL	EBT	EBR	WBL	WBT	WBR	NBL	NBT	NBR	SBL	SBT	SBR
Lane Configurations												
Sign Control		Stop			Stop			Stop			Stop	
Volume (vph)	111	187	14	20	130	35	8	80	33	25	76	78
Peak Hour Factor	0.90	0.90	0.90	0.90	0.90	0.90	0.90	0.90	0.90	0.90	0.90	0.90
Hourly flow rate (vph)	148	249	19	27	173	47	11	107	44	33	101	104
Direction, Lane #	EB 1	EB 2	WB 1	NB 1	SB 1							
Volume Total (vph)	397	19	247	161	239							
Volume Left (vph)	148	0	27	11	33							
Volume Right (vph)	0	19	47	44	104							
Hadj (s)	0.22	-0.67	-0.06	-0.12	-0.20							
Departure Headway (s)	6.4	5.5	6.1	6.4	6.1							
Degree Utilization, x	0.71	0.03	0.42	0.29	0.41							
Capacity (veh/h)	541	621	536	487	531							
Control Delay (s)	22.4	7.5	13.4	11.9	13.2							
Approach Delay (s)	21.7		13.4	11.9	13.2							
Approach LOS	C		B	B	B							
Intersection Summary												
Delay			16.4									
HCM Level of Service			C									
Intersection Capacity Utilization			61.6%	ICU Level of Service	B							
Analysis Period (min)			15									

HCM Unsignalized Intersection Capacity Analysis - PM Peak Hour  
 31: Baseline Road & Meridian Road

9/26/2012

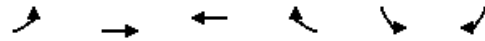

Movement	EBL	EBT	WBT	WBR	SBL	SBR
Lane Configurations	↶	↷	↷		↶	↷
Volume (veh/h)	68	341	161	32	55	59
Sign Control		Free	Free		Stop	
Grade		0%	0%		0%	
Peak Hour Factor	0.90	0.90	0.90	0.90	0.90	0.90
Hourly flow rate (vph)	91	455	215	43	73	79
Pedestrians						
Lane Width (ft)						
Walking Speed (ft/s)						
Percent Blockage						
Right turn flare (veh)						5
Median type		TWLTL	TWLTL			
Median storage (veh)		2	2			
Upstream signal (ft)						
pX, platoon unblocked						
vC, conflicting volume	257				872	236
vC1, stage 1 conf vol					236	
vC2, stage 2 conf vol					636	
vCu, unblocked vol	257				872	236
tC, single (s)	4.1				6.4	6.2
tC, 2 stage (s)					5.4	
tF (s)	2.2				3.5	3.3
p0 queue free %	93				84	90
cM capacity (veh/h)	1307				461	803













Direction, Lane #	EB 1	EB 2	WB 1	SB 1
Volume Total	91	455	257	152
Volume Left	91	0	0	73
Volume Right	0	0	43	79
cSH	1307	1700	1700	956
Volume to Capacity	0.07	0.27	0.15	0.16
Queue Length 95th (ft)	6	0	0	14
Control Delay (s)	8.0	0.0	0.0	12.0
Lane LOS	A			B
Approach Delay (s)	1.3		0.0	12.0
Approach LOS				B

Intersection Summary			
Average Delay		2.7	
Intersection Capacity Utilization		31.9%	ICU Level of Service A
Analysis Period (min)		15	

# HCM Unsignalized Intersection Capacity Analysis - PM Peak Hour

## 35: Elliot Road & Meridian Road

9/26/2012

						
Movement	EBL	EBR	NBL	NBT	SBT	SBR
Lane Configurations						
Volume (veh/h)	59	92	71	10	12	28
Sign Control	Stop			Free	Free	
Grade	0%			0%	0%	
Peak Hour Factor	0.90	0.90	0.90	0.90	0.90	0.90
Hourly flow rate (vph)	79	123	95	13	16	37
Pedestrians						
Lane Width (ft)						
Walking Speed (ft/s)						
Percent Blockage						
Right turn flare (veh)						
Median type						
TWLTL TWLTL						
Median storage veh						
2 2						
Upstream signal (ft)						
pX, platoon unblocked						
vC, conflicting volume	237	35	53			
vC1, stage 1 conf vol	35					
vC2, stage 2 conf vol	203					
vCu, unblocked vol	237	35	53			
tC, single (s)	6.4	6.2	4.1			
tC, 2 stage (s)	5.4					
tF (s)	3.5	3.3	2.2			
p0 queue free %	90	88	94			
cM capacity (veh/h)	758	1038	1552			
Direction, Lane #	EB 1	EB 2	NB 1	NB 2	SB 1	
Volume Total	79	123	95	13	53	
Volume Left	79	0	95	0	0	
Volume Right	0	123	0	0	37	
cSH	758	1038	1552	1700	1700	
Volume to Capacity	0.10	0.12	0.06	0.01	0.03	
Queue Length 95th (ft)	9	10	5	0	0	
Control Delay (s)	10.3	8.9	7.5	0.0	0.0	
Lane LOS	B	A	A			
Approach Delay (s)	9.5		6.5		0.0	
Approach LOS	A					
Intersection Summary						
Average Delay			7.2			
Intersection Capacity Utilization			22.0%	ICU Level of Service	A	
Analysis Period (min)			15			



# HCM Unsignalized Intersection Capacity Analysis - PM Peak Hour

## 37: Warner Road & Meridian Road

9/26/2012



Movement	EBL	EBR	NBL	NBT	SBT	SBR
Lane Configurations						
Volume (veh/h)	4	8	6	22	24	8
Sign Control	Stop			Free	Free	
Grade	0%			0%	0%	
Peak Hour Factor	0.90	0.90	0.90	0.90	0.90	0.90
Hourly flow rate (vph)	5	11	8	29	32	11
Pedestrians						
Lane Width (ft)						
Walking Speed (ft/s)						
Percent Blockage						
Right turn flare (veh)						
Median type				None	TWLTL	
Median storage (veh)					2	
Upstream signal (ft)						
pX, platoon unblocked						
vC, conflicting volume	83	37	43			
vC1, stage 1 conf vol	37					
vC2, stage 2 conf vol	45					
vCu, unblocked vol	83	37	43			
tC, single (s)	6.4	6.2	4.1			
tC, 2 stage (s)	5.4					
tF (s)	3.5	3.3	2.2			
p0 queue free %	99	99	99			
cM capacity (veh/h)	934	1035	1566			
<b>Direction, Lane #</b>	<b>EB 1</b>	<b>NB 1</b>	<b>SB 1</b>			
Volume Total	16	37	43			
Volume Left	5	8	0			
Volume Right	11	0	11			
cSH	999	1566	1700			
Volume to Capacity	0.02	0.01	0.03			
Queue Length 95th (ft)	1	0	0			
Control Delay (s)	8.7	1.6	0.0			
Lane LOS	A	A				
Approach Delay (s)	8.7	1.6	0.0			
Approach LOS	A					
<b>Intersection Summary</b>						
Average Delay			2.1			
Intersection Capacity Utilization			17.6%	ICU Level of Service	A	
Analysis Period (min)			15			

# APPENDIX B

## WORKING PAPER #2: EVALUATION CRITERIA AND PLAN FOR IMPROVEMENTS

**Baker**

**Michael Baker Jr., Inc.**  
*Phoenix, Arizona*

May 2013

# Meridian Road Corridor Study

## Germann Road to McDowell Boulevard

### Working Paper #2

### Evaluation Criteria and Plan for Improvements

*Prepared for:*



PINAL COUNTY

*Wide open opportunity*



*Prepared by*

**Baker**

**Michael Baker Jr., Inc.**  
*Phoenix, Arizona*

## **Table of Contents**

- I. Introduction ..... 1
  - Study Area..... 1
  - Study Objectives ..... 3
  - Report Objectives..... 3
- II. Vision and Goals..... 3
- III. Traffic Impacts..... 4
  - Roadway Segment Lane Configurations ..... 4
  - Intersection Configurations ..... 14
- IV. Development of Roadway Alternatives ..... 22
  - Meridian Road Alignment Alternatives..... 22
    - Conceptual Analysis for Northern Section of Meridian Road ..... 22
    - Conceptual Alternatives for Southern Section of Meridian Road ..... 22
    - Section Line Shift at Baseline Road ..... 23
- V. Evaluation ..... 26
  - Evaluation Criteria..... 26
  - Initial Alternative Screening..... 26
    - Alternative 1 – No-Build Alternative ..... 27
    - Alternative 2 – Section Line Alignment..... 27
    - Alternative 3 – Eastern Shift ..... 28
    - Alternative 4 – Meandering Alignment ..... 28
  - Preferred Meridian Road Alignment..... 28
  - Preferred Section Line Shift ..... 28
- VI. Design Features..... 29
  - Functional Classification and Typical Cross Section..... 29
  - Interim Conditions ..... 30
  - Phased Construction ..... 32
    - Near-Term Improvement Recommendations..... 32
    - Mid-Term Improvement Recommendations ..... 32
    - Long-Term Improvement Recommendations..... 33
    - Ultimate Improvement Recommendations ..... 33

Existing Right-of-Way .....	33
Required Right-of-Way .....	34
Cost Estimate .....	36
East Mesa Area Drainage Master Plan (ADMP) .....	40
Access Management .....	43
Access Management Recommendations.....	44
Intersection Spacing.....	46
Driveway Locations .....	46
Median Locations.....	46
Additional Recommendations .....	46
Evaluation of Non-Motorized Modes of Transportation .....	46
Evaluation of Transit Needs .....	47

### **List of Figures**

Figure 1: Study Area .....	2
Figure 2: 2025 Daily Traffic Volumes .....	5
Figure 3: 2035 Daily Traffic Volumes .....	6
Figure 4: 2025 Average Daily Level of Service .....	9
Figure 5: 2035 Average Daily Level of Service .....	10
Figure 6: 2025 Recommended Roadway Configuration .....	12
Figure 7: 2035 Recommended Roadway Configuration .....	13
Figure 8: 2025 Turning Movement Volumes .....	15
Figure 9: 2035 Turning Movement Volumes .....	16
Figure 10: 2025 Intersection Lane Configuration .....	17
Figure 11: 2035 Intersection Lane Configuration .....	18
Figure 12: 2025 Intersection Level of Service .....	19
Figure 13: 2035 Intersection Level of Service.....	20
Figure 14: Conceptual Alternatives for Southern Section of Meridian Road .....	24
Figure 15: Section Line Shift at Baseline Road Alternatives .....	25
Figure 16: Ultimate Roadway Cross Section – Southern Avenue to Germann Road.....	29
Figure 17: Ultimate Roadway Cross Section – Lost Dutchman Boulevard to Southern Avenue .....	30
Figure 18: Ultimate Roadway Cross Section – Lost Dutchman Boulevard to McDowell Boulevard.....	30
Figure 19: Interim Cross Section: McDowell Boulevard to Lost Dutchman Boulevard .....	31
Figure 20: Interim Cross Section: Lost Dutchman Boulevard to Germann Road.....	32
Figure 21: Interim Cross Section: Southern Avenue to Germann Road .....	32
Figure 22: East Mesa ADMP Alternative Overview.....	42
Figure 23: Roadway/Channel Combined Cross Section .....	42
Figure 24: Access versus Mobility for a Given Roadway.....	43



## List of Tables

Table 1: 2025 and 2035 Daily Traffic Volumes.....	4
Table 2: Annual Average Daily Volume Threshold Values for Various Facility Types .....	8
Table 3: Level-of-Service Criteria for Signalized Intersections.....	14
Table 4: 2025 Meridian Road Intersection Lane Configuration Deviations .....	21
Table 5: 2035 Meridian Road Intersection Lane Configuration Deviations .....	21
Table 8: Initial Alternative Screening Results.....	26
Table 9: 2035 No-Build Average Daily Traffic and Level-of-Service .....	27
Table 10: Side-by-Side Comparison of Roadway Typical Sections .....	29
Table 6: Existing Right-of-Way .....	35
Table 7: Right-of-Way Requirement .....	36
Table 11: Summary of Corridor Segment Estimates .....	37
Table 12: Itemized Cost Estimate for Near-Term Recommendations .....	38
Table 13: Itemized Cost Estimate for the Northern Segment under Mid-Term Recommendations: McDowell Boulevard to Southern Avenue .....	38
Table 14: Itemized Cost Estimate for the Northern Segment under Long-Term Recommendations: McDowell Boulevard to Southern Avenue .....	39
Table 15: Itemized Cost Estimate for the Preferred Corridor under Mid/Long-Term Recommendations: Southern Avenue to Germann Road.....	39
Table 16: Itemized Cost Estimate for the Preferred Corridor under Ultimate Recommendations: Southern Avenue to Germann Road.....	40
Table 17: Access Control Guidelines per Jurisdiction (for Urban Arterial Roads).....	45
Table 18: Access Control Guidelines per Jurisdiction (for Urban Arterial Roads).....	45

## I. Introduction

Continued development along the Meridian Road corridor will lead to significant traffic increases in the future. Currently, there are only two north-south roadways that connect US 60 to Hunt Highway. The closest through route is Ironwood Drive, one mile east of Meridian Road. The other through route, Ellsworth Road, is three miles west. If either of these roads becomes obstructed, significant traffic delays will occur because no intermediate thoroughfare exists.

Meridian Road has been identified in the long range transportation plans of all local agencies plus the Maricopa Association of Governments (MAG) and Central Arizona Governments (CAG). The principal focus of the Meridian Road Corridor Study is to address the transportation planning needs identified by the jurisdictions and more particularly to lead the local jurisdictions to develop consensus on facility type, number of lanes and right-of-way requirements to guide the future development of the road. This could be memorialized through a memorandum of understanding.

### Study Area

The study area for the Meridian Road Corridor Study is approximately 13 miles in length and is generally bounded by Germann Road on the south, McDowell Boulevard on the north, Ironwood Road on the east and Signal Butte Road on the west. Meridian Road is a section line alignment road that is located on the boundary between Pinal County and Maricopa County. The Cities of Apache Junction and Mesa and the Counties of Maricopa and Pinal along with the Town of Queen Creek all control portions of Meridian Road. Although Arizona State Land Department (ASLD) does not control portions of Meridian Road, ASLD does own a majority of the land to the east of Meridian Road, south of Baseline Road. Currently, Meridian Road is a discontinuous road within the study area. Meridian Road is a paved two-lane roadway from McDowell Boulevard to Baseline Road and between a half mile north of Elliot Road and a half mile south of Warner Road. The remaining segments of Meridian Road within the study area are a discontinuous dirt trail.

The study area is depicted in **Figure 1**.



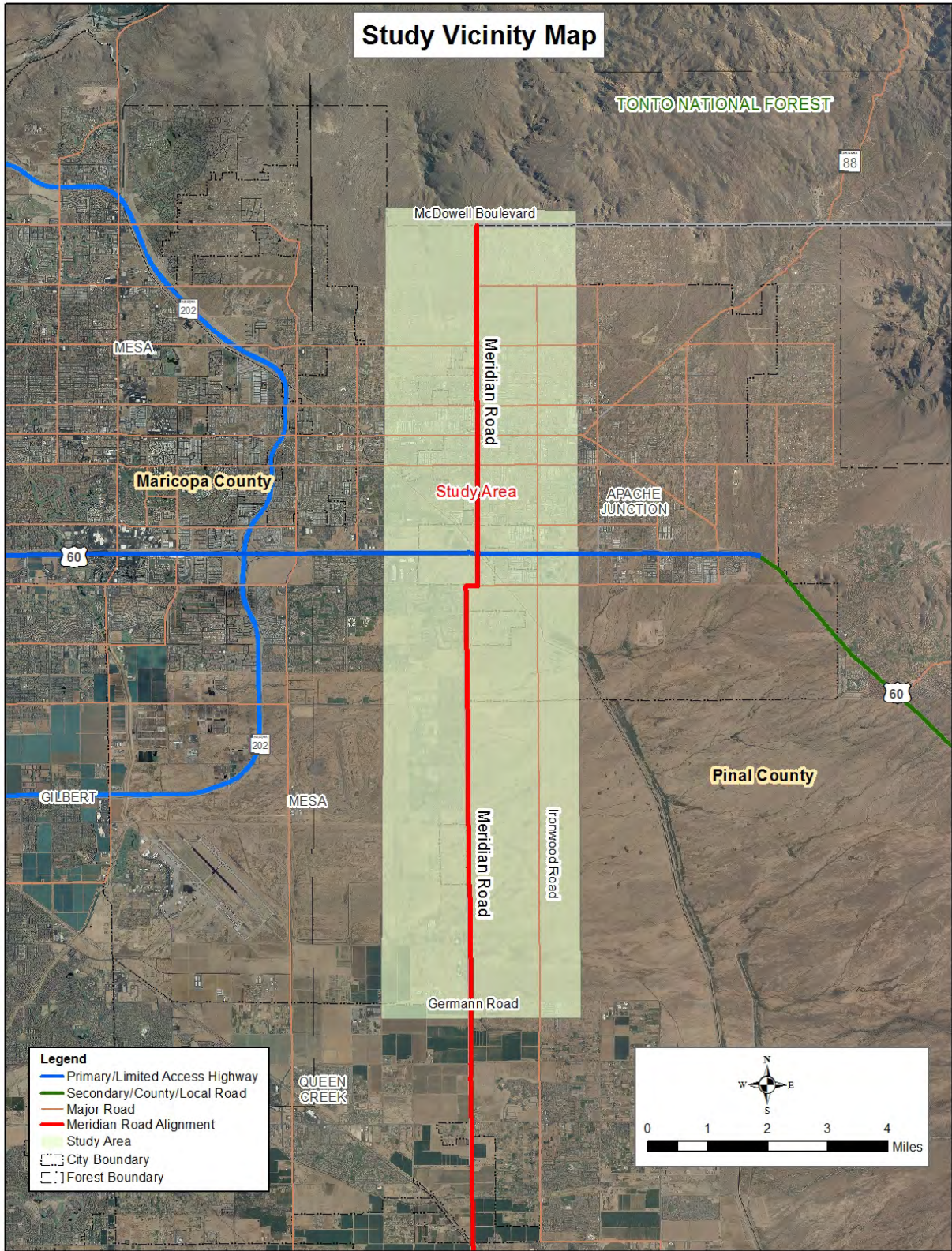

Figure 1: Study Area

## Study Objectives

The purpose of the Meridian Road corridor Study is to document conditions along the existing roadway and to develop alternatives that will increase the safety and future level of service (LOS) of Meridian Road. This study will also establish a roadway footprint and develop the ultimate right-of-way requirement for the corridor. Finally, the study will be utilized as a guide for local agencies and future development along the corridor.

In order to address the needs and purposes of the Meridian Road Corridor Study a number of goals and objectives were agreed to with Stakeholders during the kick-off meeting. These goals and objectives area as follows:

- Identify and address planning level issues prior to the initiation programming and engineering design.
- Evaluate the future transportation needs of the corridor and identify the facility type, and the number of interim and ultimate lanes.
- Develop an implementation plan to bring about the recommended improvements, while acknowledging the need for sufficient flexibility to adapt to future changes.
- Identify and evaluate a preferred alignment within the southern portion of the corridor.
- Determine the required right-of-way requirements for the corridor
- To establish a consensus among the Arizona Department of Transportation (ADOT), local agencies/jurisdictions and private stakeholders regarding the preferred interim and ultimate facility type, and access control design elements for the corridor.
- Document the preferred facility location/concept alternatives and provide the necessary planning input to enable ADOT and the local agencies to move forward in the design and environmental process.

## Report Objectives

Using generally accepted planning criteria and the findings from *Working Paper #1: Existing and Future Conditions Inventory*, the objective of Working Paper #2 is to recommend roadway typical sections, a preferred alignment and implementation strategies that address identified deficiencies and special needs, while categorizing the population and traffic volume thresholds required for improvements. Working Paper #2 will document the corridor evaluation process, recommended facility type and typical roadway section, and implementation/phasing plan.

## II. Vision and Goals

The proposed project is needed to support the continuing development and growth, occurring and anticipated, in the East Mesa, West Apache Junction, and the San Tan Valley region. Significant growth is anticipated in this region that could result in population growth, economic development, and increased traffic volumes. The purpose of this study is to evaluate the growing demands placed on local roads and streets by development in the region. The study will address the transportation planning needs identified by the jurisdictions and more particularly to lead the local jurisdictions to develop consensus on socio-economic demographic, modeling forecasts, roadway facility type, number of lanes, and right-of-way requirements to



guide the future development of the road. The study will also include roadway improvement phasing plans, cost estimates and implementation plans. Additionally, the study will examine multimodal opportunities necessary to accommodate growth and development, such as, bicycle and pedestrian needs.

### III. Traffic Impacts

#### Roadway Segment Lane Configurations

2025 and 2035 daily traffic volumes developed in *Working Paper #1: Existing and Future Conditions Inventory* were used to calculate the level of service (LOS) for the study area roadway segments. The 2025 and 2035 daily traffic volumes are shown in **Table 1** and graphically in **Figure 2** and **Figure 3**, respectively.

**Table 1: 2025 and 2035 Daily Traffic Volumes**

Meridian Road Segment	Direction	2025 ADT	2035 ADT
McDowell Boulevard to McKellips Boulevard	NB	0-5,000*	0-5,000*
	SB		
McKellips Boulevard to Brown Road/Lost Dutchman Boulevard	NB	0-5,000*	0-5,000*
	SB		
Brown Road/Lost Dutchman Boulevard to University Drive/Superstition Boulevard	NB	0-5,000*	5,001-10,000*
	SB		
University Drive/Superstition Boulevard to Apache Trail	NB	5,001-10,000*	10,001-20,000*
	SB		
Apache Trail to Broadway Road	NB	5,001-10,000*	10,001-20,000*
	SB		
Broadway Road to Southern Avenue	NB	5,001-10,000*	10,001-20,000*
	SB		
Southern Avenue to US 60	NB	10,001-20,000*	20,001-30,000*
	SB		
US 60 to Baseline Road	NB	14,315	14,761
	SB	14,709	15,129
Baseline Road to Guadalupe Road	NB	12,087	12,445
	SB	12,070	12,434
Guadalupe Road to Elliot Road	NB	6,664	5,878
	SB	6,618	5,994
Elliot Road to Warner Road	NB	14,945	13,251
	SB	14,621	13,376
Warner Road to Ray Road	NB	9,647	8,312
	SB	8,666	8,339
Ray Road to Williams Field Road	NB	8,835	9,355
	SB	7,775	9,473
Williams Field Road to SR 24	NB	12,846	4,413
	SB	12,516	5,347
SR 24 to Pecos Road	NB	10,556	15,484
	SB	10,226	16,181
Pecos Road to Germann Road	NB	6,516	10,751
	SB	6,076	11,586

\*ADT range as shown in the Apache Junction Comprehensive Transportation Study for population levels 2 and 3

NB: Northbound

SB: Southbound



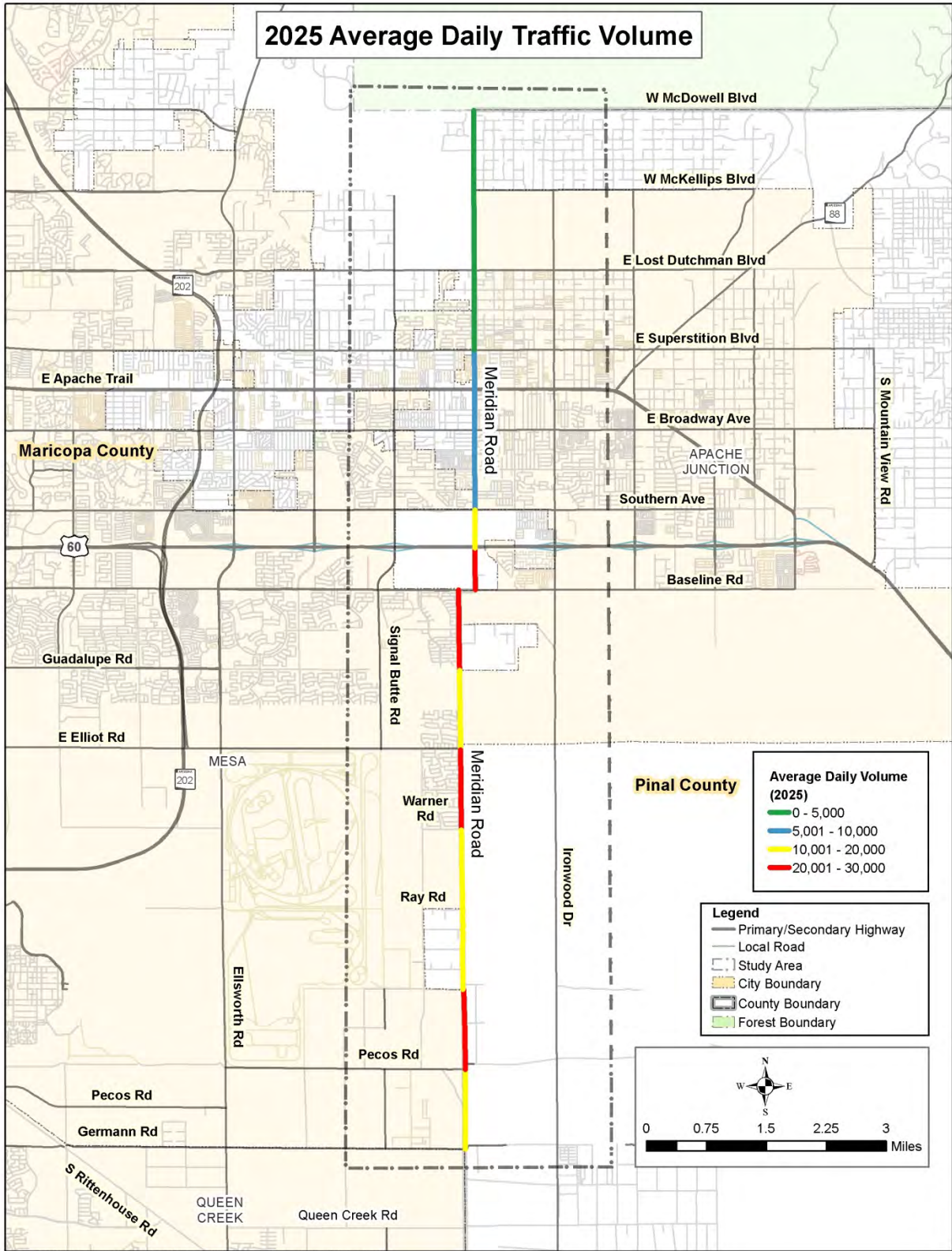

**Figure 2: 2025 Daily Traffic Volumes**

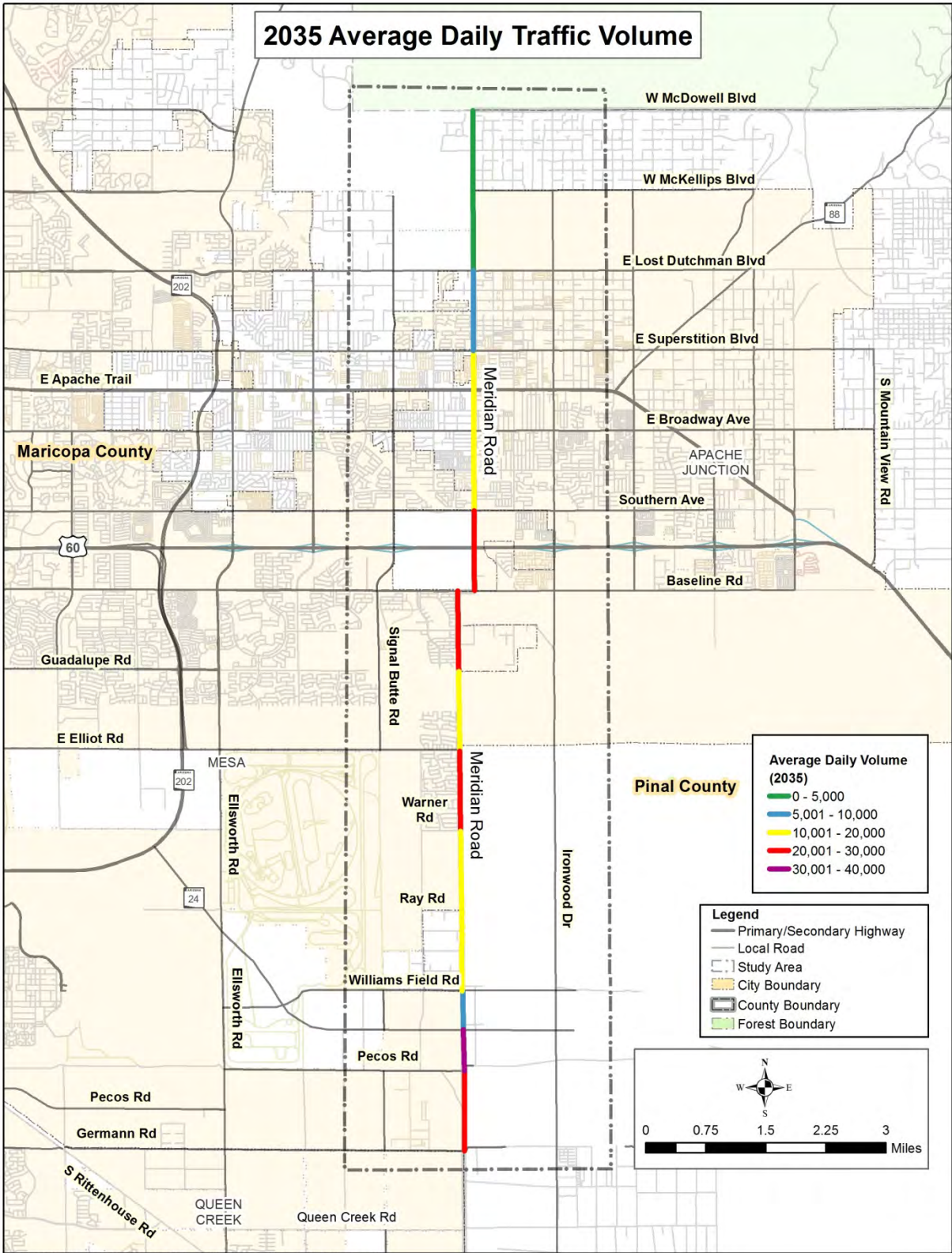

Figure 3: 2035 Daily Traffic Volumes



The ability of a transportation system to transmit the transportation demand is characterized as its level of service (LOS). LOS is a rating system from “A”, representing the best operation, to “F”, representing the worst operation. The appropriate reference for LOS operation is the *Highway Capacity Manual*, published by the Transportation Research Board. In general, LOS A and B represent no congestion, LOS C and D represent moderate congestion, and LOS E and F represent severe congestion. The MCDOT Roadway Design Manual (revised 2011) establishes LOS C as the desired criteria for rural principal arterial roadways and LOS D as the desired criteria for urban principal arterial roadways. The City of Mesa Transportation Plan and City of Apache Junction Small Area Transportation Study establishes LOS D as the desired criteria for principal arterial roadways. Because Meridian Road is likely to ultimately be a principal arterial under the jurisdiction of the City of Mesa and the City of Apache Junction, LOS D was used as the desired LOS for future traffic operations within the corridor.

The widely accepted 2009 Quality/Level of Service Handbook published by the Florida Department of Transportation contains planning guidelines relating LOS to daily volumes to estimate capacity for roadway segments. These guidelines are not an exact description of the actual operating LOS on a particular roadway segment, but they give an indication of when the roadway falls below acceptable levels of service. The *Highway Capacity Manual* is the foremost recognized and accepted analysis tool for automobile capacity and quality/level of service analysis. FDOT’s Quality/Level of Service Handbook are nationally recognized as the leading planning application of *Highway Capacity Manual* for the evaluation of automobile LOS.

Arterial street capacity thresholds were derived directly from “Table 4-1, Generalized Annual Average Daily Volumes for Florida’s Urbanized Areas (Freeway & State Two-Way Arterial Facilities),” published by the Florida Department of Transportation (FDOT) in the widely accepted 2009 Quality/Level of Service Handbook. Information relevant to arterial facilities in FDOT’s 2009 Quality/Level of Service Handbook served as reference for the development of specific values to reflect current Metropolitan Phoenix area conditions and future conditions anticipated to exist ultimately in the Study Area. Pertinent data related to the 2009 Quality/Level of Service Handbook is included in **Appendix A**.

The number of lanes depicted in the Maricopa Association of Governments (MAG) models introduced in *Working Paper #1: Existing and Future Conditions Inventory* were used to determine the LOS. MAG indicated a three-lane section for Meridian Road in 2025 and 2035 within the study area. The LOS thresholds for a two-lane undivided roadway, as shown in FDOT’s “Table 4-1, Generalized Annual Average Daily Volumes for Florida’s Urbanized Areas (Freeway & State Two-Way Arterial Facilities),” were increase by 5% to account for a center lane or exclusive left-turn lanes. By adding a center lane or exclusive left-turn lane, vehicles making a left-turn are removed out of the through lanes thus increasing the capacity of the roadway.

**Table 2** shows the Average Daily Traffic (ADT) capacity threshold values by facility type calculated for LOS A/B, C and D. These threshold values were used to determine the roadway segment LOS for 2025 and 2035 for this study. **Figure 4** and **Figure 5** depict the 2025 and 2035 LOS for segments of Meridian Road within the Study Area, respectively.

**Table 2: Annual Average Daily Volume Threshold Values for Various Facility Types**

Number of Through Lanes	Median	Level of Service Threshold		
		A/B	C	D
2	Undivided	9,600	15,400	16,500
3	Divided/Two-way Left-turn Lane	10,080	16,170	17,325
4	Divided	29,300	35,500	36,700

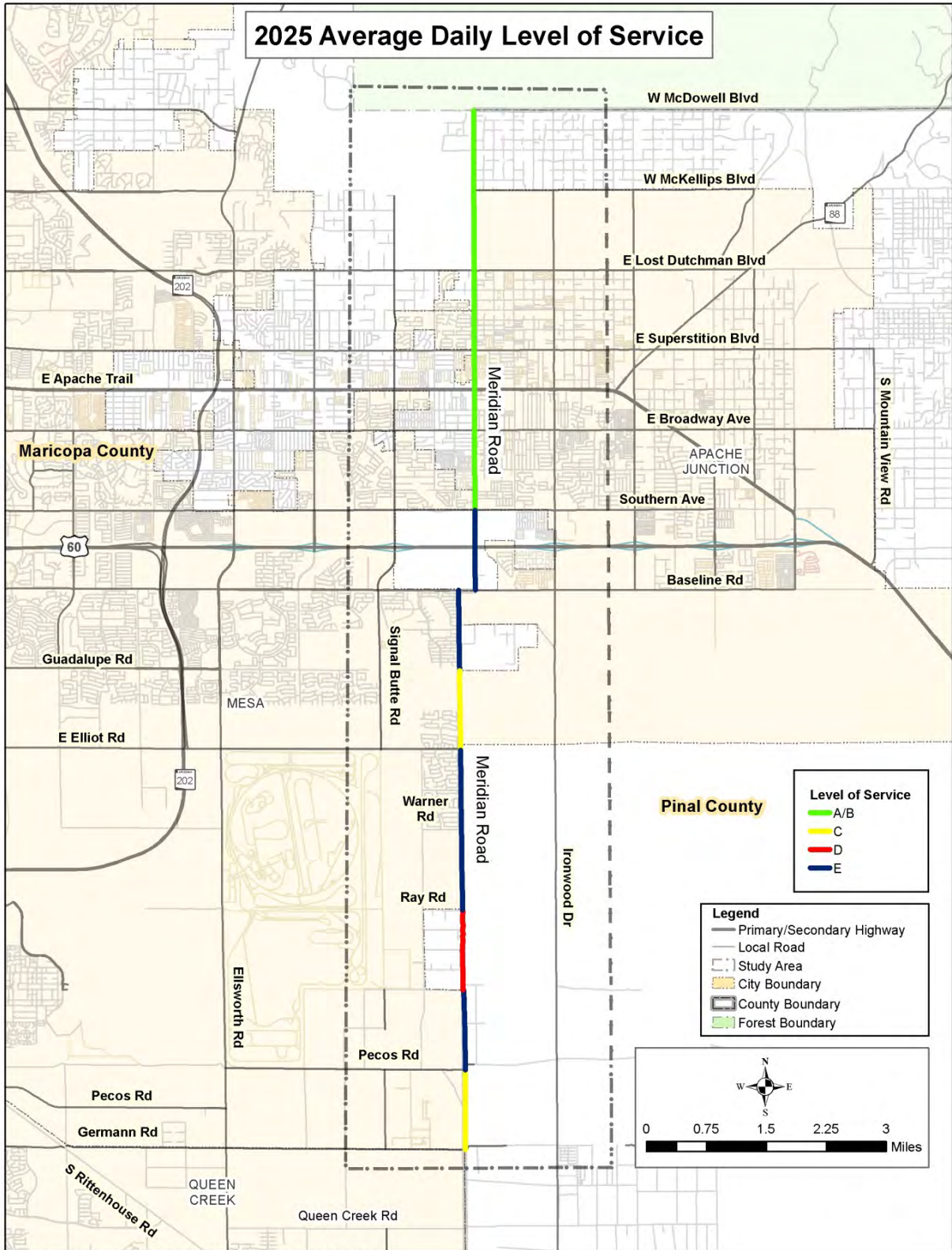
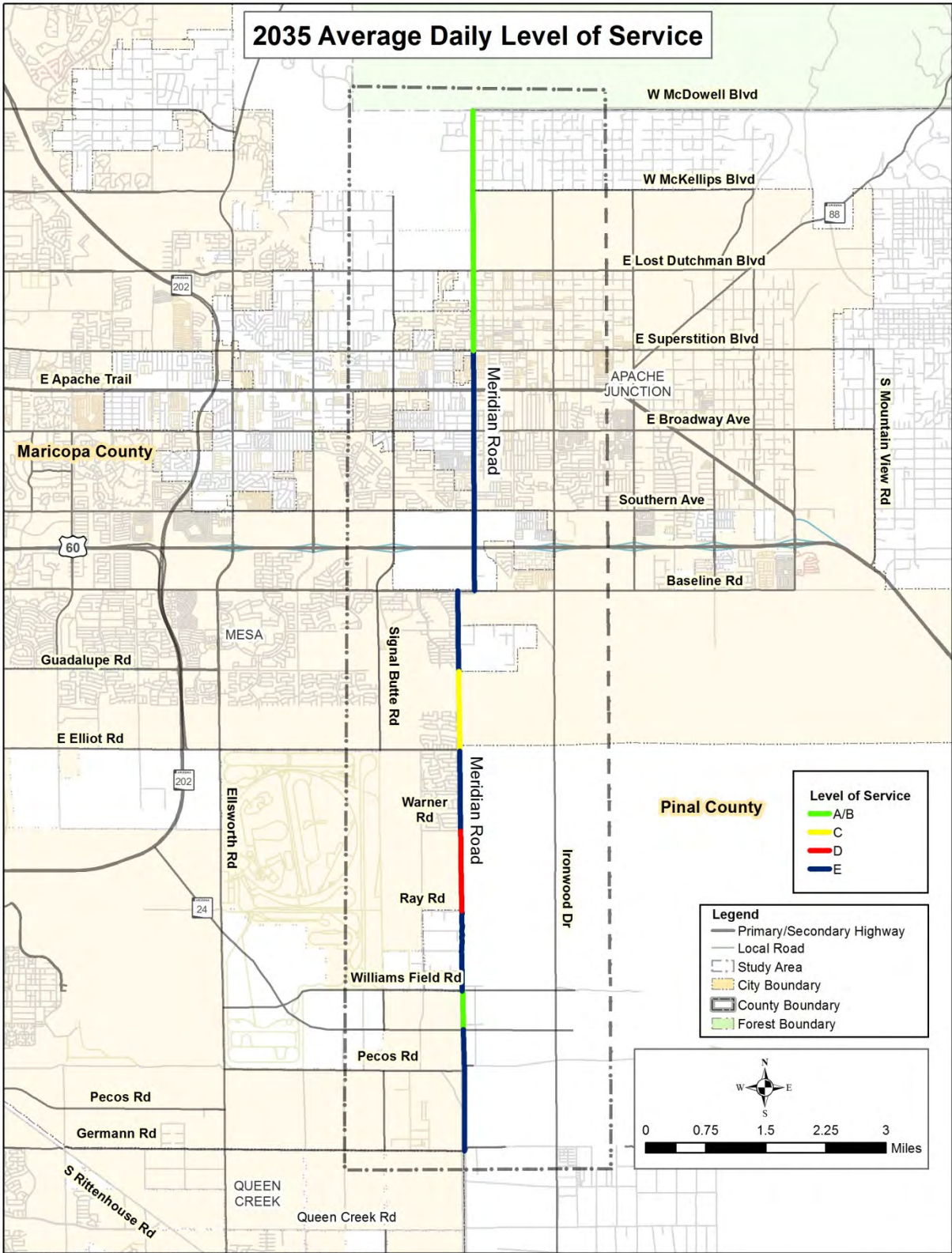

Figure 4: 2025 Average Daily Level of Service





**Figure 5: 2035 Average Daily Level of Service**

As indicated, LOS D was considered the threshold of acceptable operations for arterial facilities. The LOS threshold measures reflect the traffic volume characteristics of each facility or grouping of facility types. The selection of these LOS threshold values accounts for the expectations of the drivers as well as the relative costs associated with the construction of each facility type. ADT volumes in excess of the LOS D thresholds illustrated in **Table 2** indicate a condition in which the volumes on a given roadway segment exceed the planning-level capacity for that facility.

The results of the 2025 LOS analysis for a roadway segment indicate that most segments of Meridian Road south of Southern Avenue will operate unacceptably as a three-lane section. Based on the projected ADT volumes for year 2025 shown in **Table 1** and the ADT capacity thresholds shown in **Table 2**, it is anticipated that Meridian Road will operate within the threshold of acceptable operations at a LOS of C or better as a two-lane undivided roadway between McDowell Boulevard and Lost Dutchman Boulevard, as a three-lane section south of Lost Dutchman Boulevard to Southern Avenue and as four-lane divided roadway south of Southern Avenue to Germann Road. The results of the 2025 roadway segment analysis is depicted in **Figure 6**.

The results of the 2035 LOS analysis for a roadway segment indicate that most segments of Meridian Road south of Superstition Boulevard will operate unacceptably as a three-lane section. Based on the projected ADT volumes for year 2035 shown in **Table 1** and the ADT capacity thresholds shown in **Table 2**, it is anticipated that Meridian Road will operate within the threshold of acceptable operations at a LOS of C or better as a two-lane undivided roadway between McDowell Boulevard and Lost Dutchman Boulevard and as four-lane divided roadway south of Lost Dutchman Boulevard to Germann Road. The results of the 2035 roadway segment analysis is depicted in **Figure 7**.

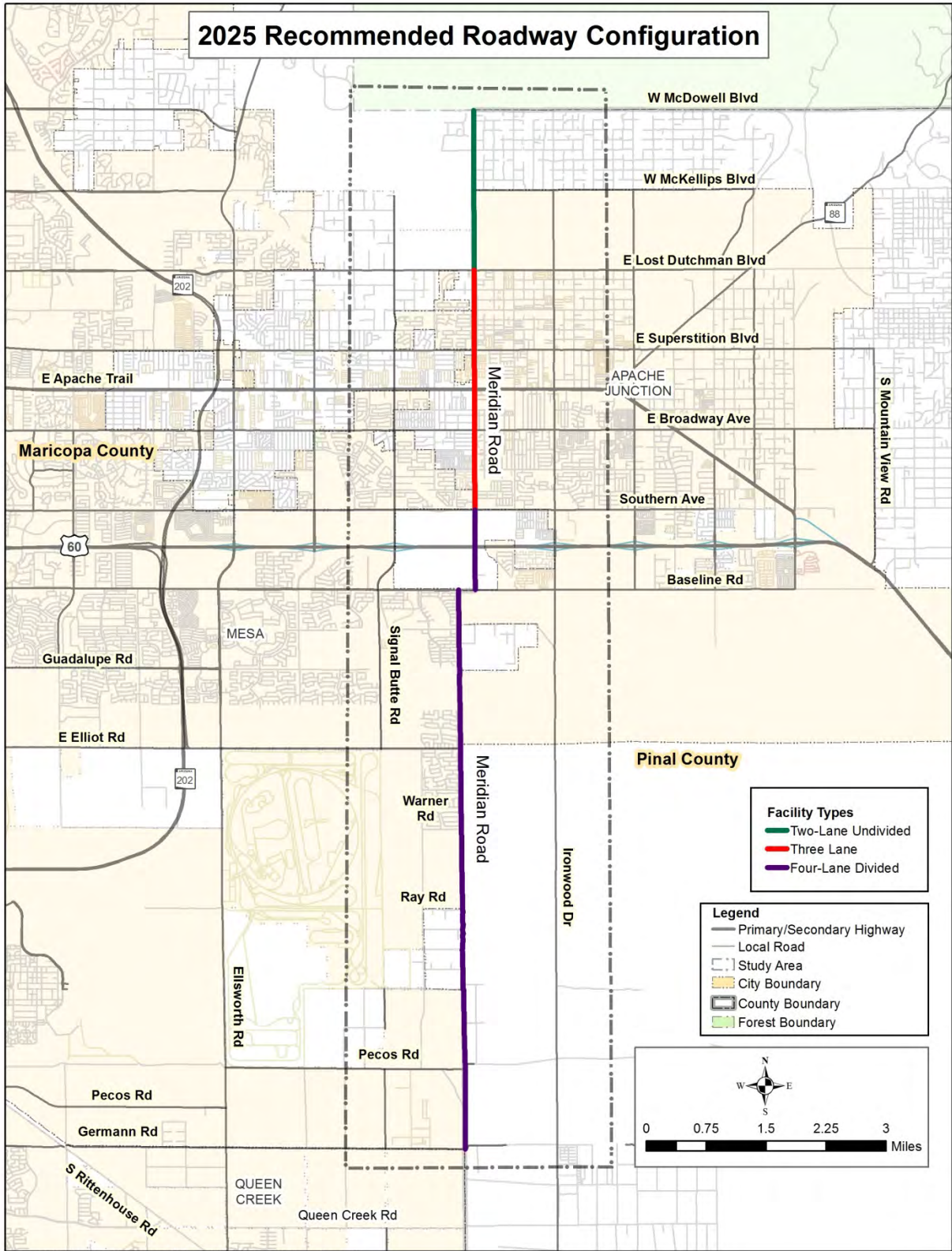

Figure 6: 2025 Recommended Roadway Configuration



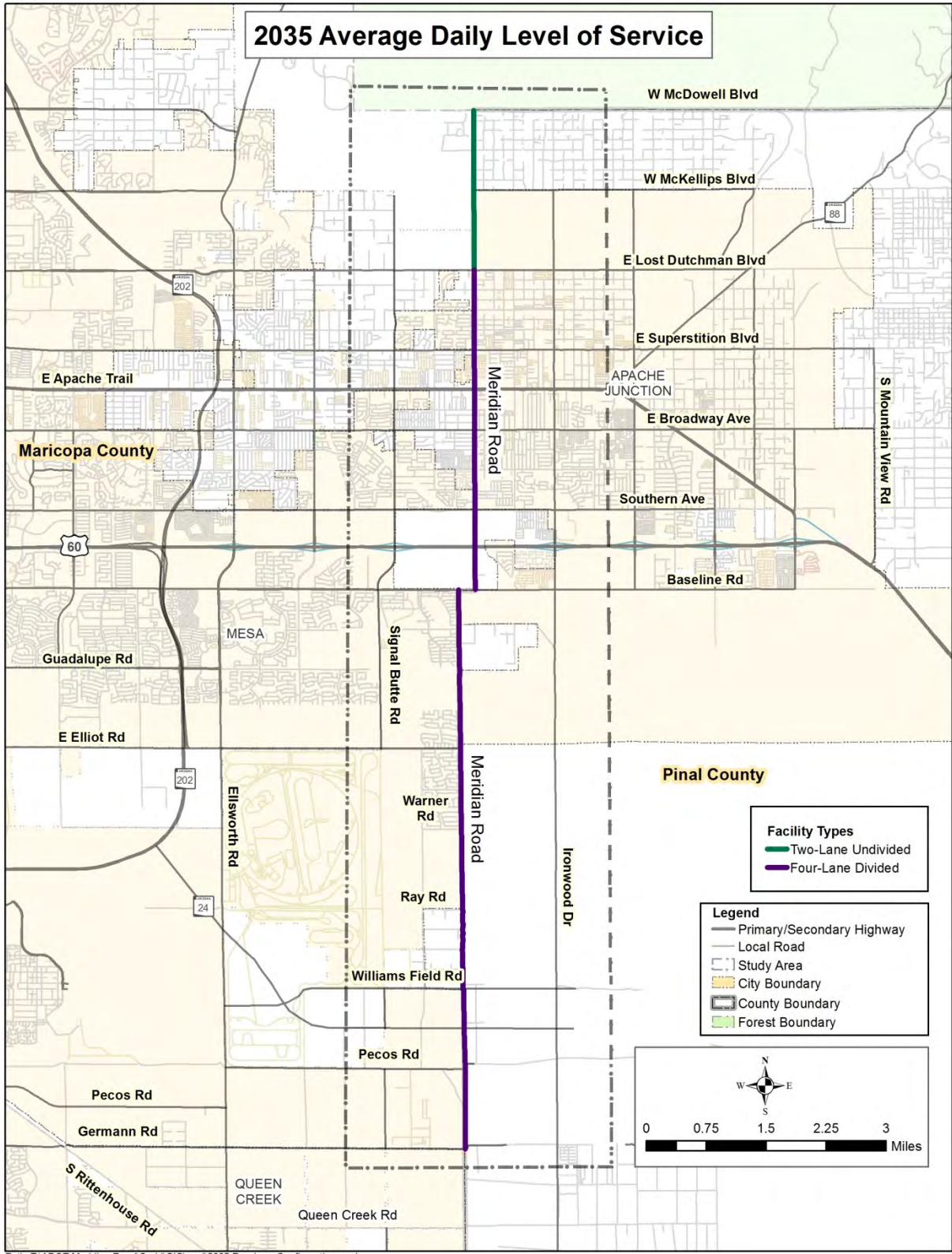

Figure 7: 2035 Recommended Roadway Configuration

### Intersection Configurations

2025 and 2035 turning movement volumes developed in *Working Paper #1: Existing and Future Conditions Inventory* were used to calculate the LOS for the study area intersections. Turning movement volume forecasts are shown in **Figure 8** and **Figure 9**, respectively for 2025 and 2035.

The *Highway Capacity Manual* considers the average delay per vehicle as the measure to determine the LOS of a signalized intersection. The delay and LOS are calculated for the intersection, each approach, and each turning movement. **Table 3** lists the LOS criteria for signalized intersections as stated in the *Highway Capacity Manual*.

**Table 3: Level-of-Service Criteria for Signalized Intersections**

Level-of-Service	Average Control Delay (s/veh)
A	≤ 10
B	> 10-20
C	> 20-35
D	> 35-55
E	> 55-80
F	> 80

One of the important conditions for determining LOS at an intersection is the number of lanes provided for each movement on each approach at the intersection. The 2025 and 2035 intersection geometry for the study area intersections, shown in **Figure 10** and **Figure 11** respectively, was developed based on the findings of the roadway segment LOS analysis completed in the previous section, *Roadway Segment Lane Configuration*. The results of the intersection LOS analysis will indicate how each intersection will be widened to accommodate turn lanes and additional through lanes.

The LOS for the study area intersections was evaluated using Synchro software, which utilizes the criteria described in **Table 3**. The 2025 and 2035 LOS for the signalized intersections within the study area are shown in **Figure 12** and **Figure 13**, respectively. **Appendix B** provides the complete results of the 2025 and 2035 LOS analyses.



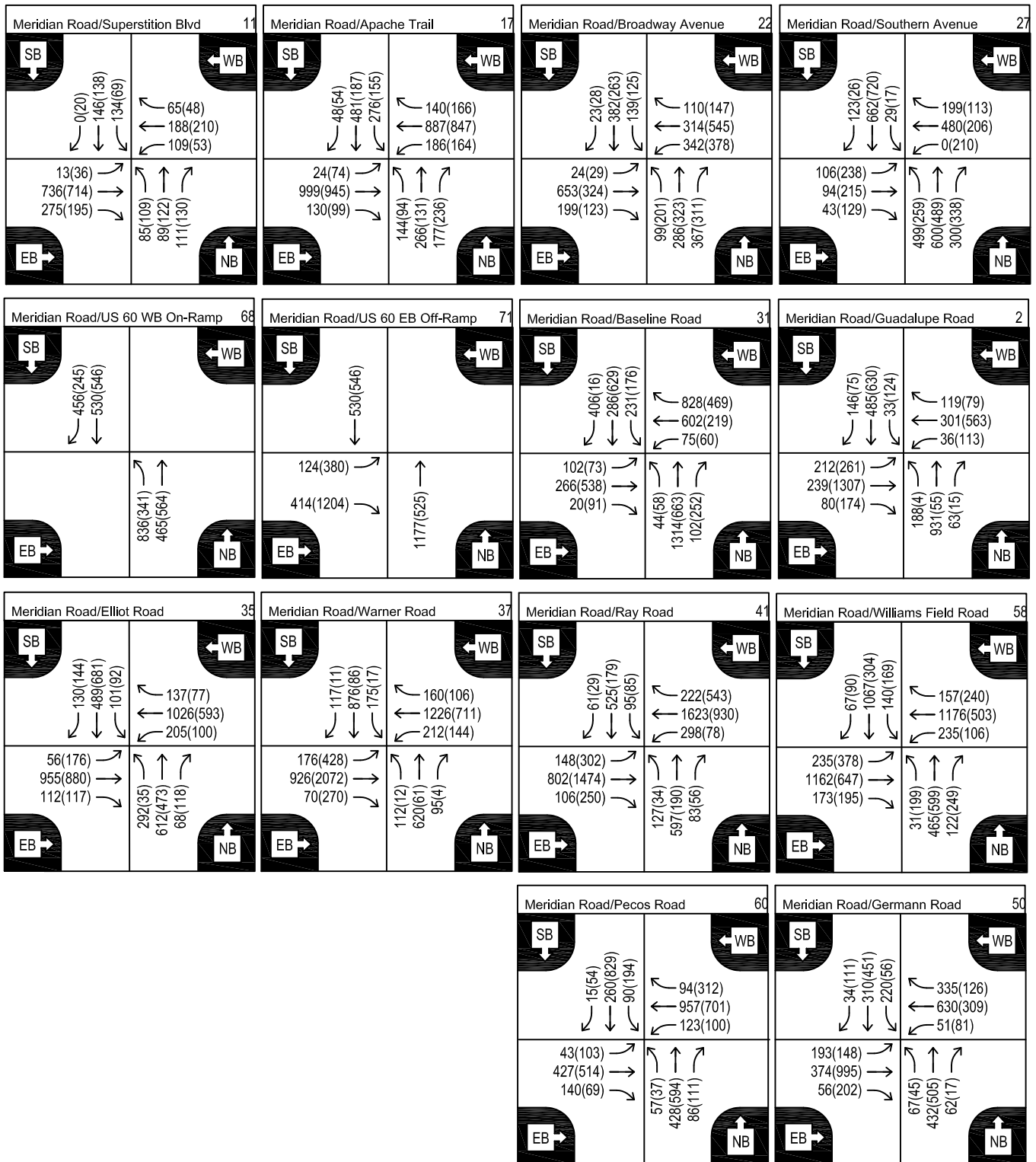

**Legend**  
 ← AM (PM) Peak Hour Volume

Figure 8  
 2025 Turning Movement Volumes

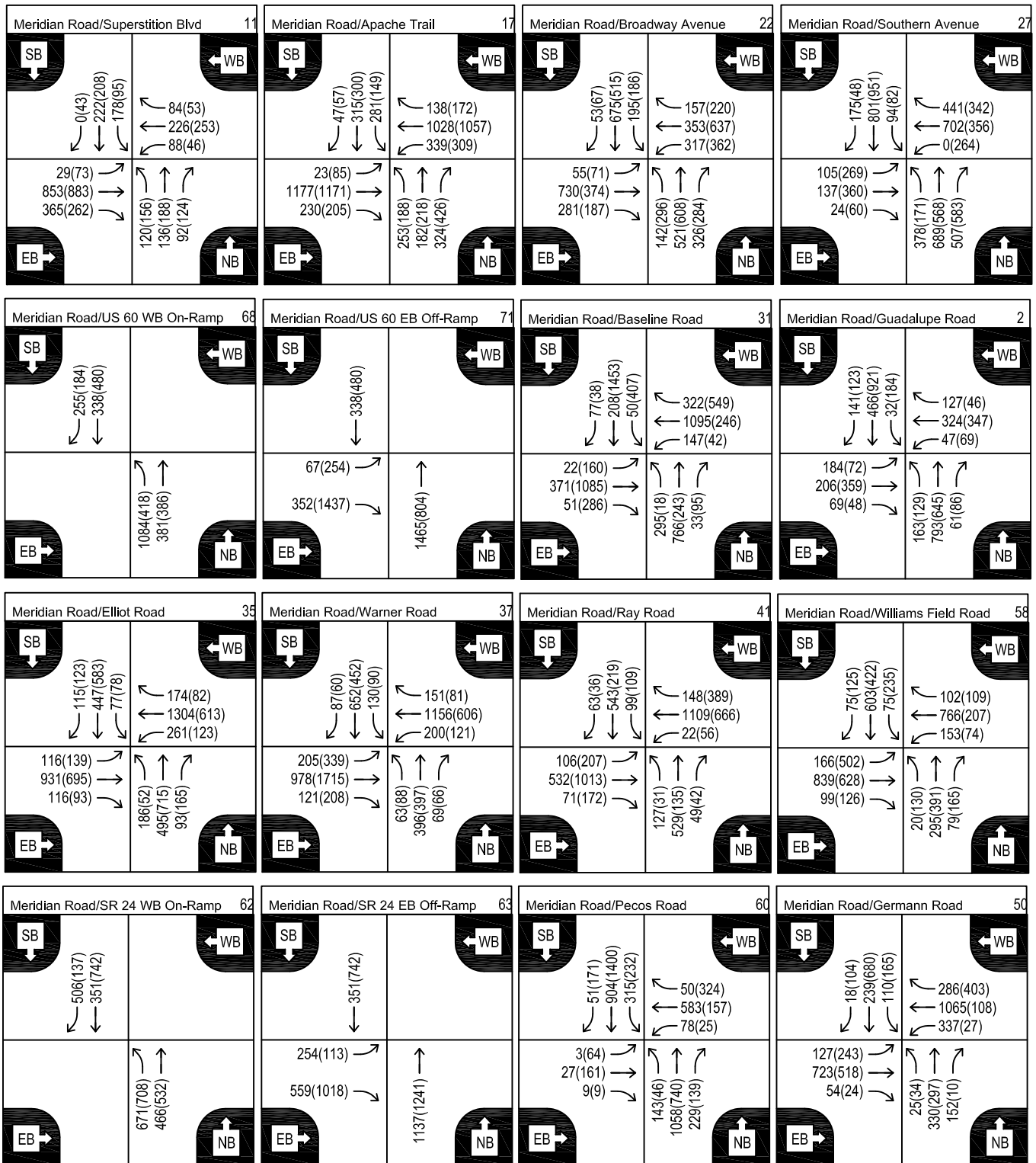

**Legend**  
 ← AM (PM) Peak Hour Volume

Figure 9  
 2035 Turning Movement Volumes

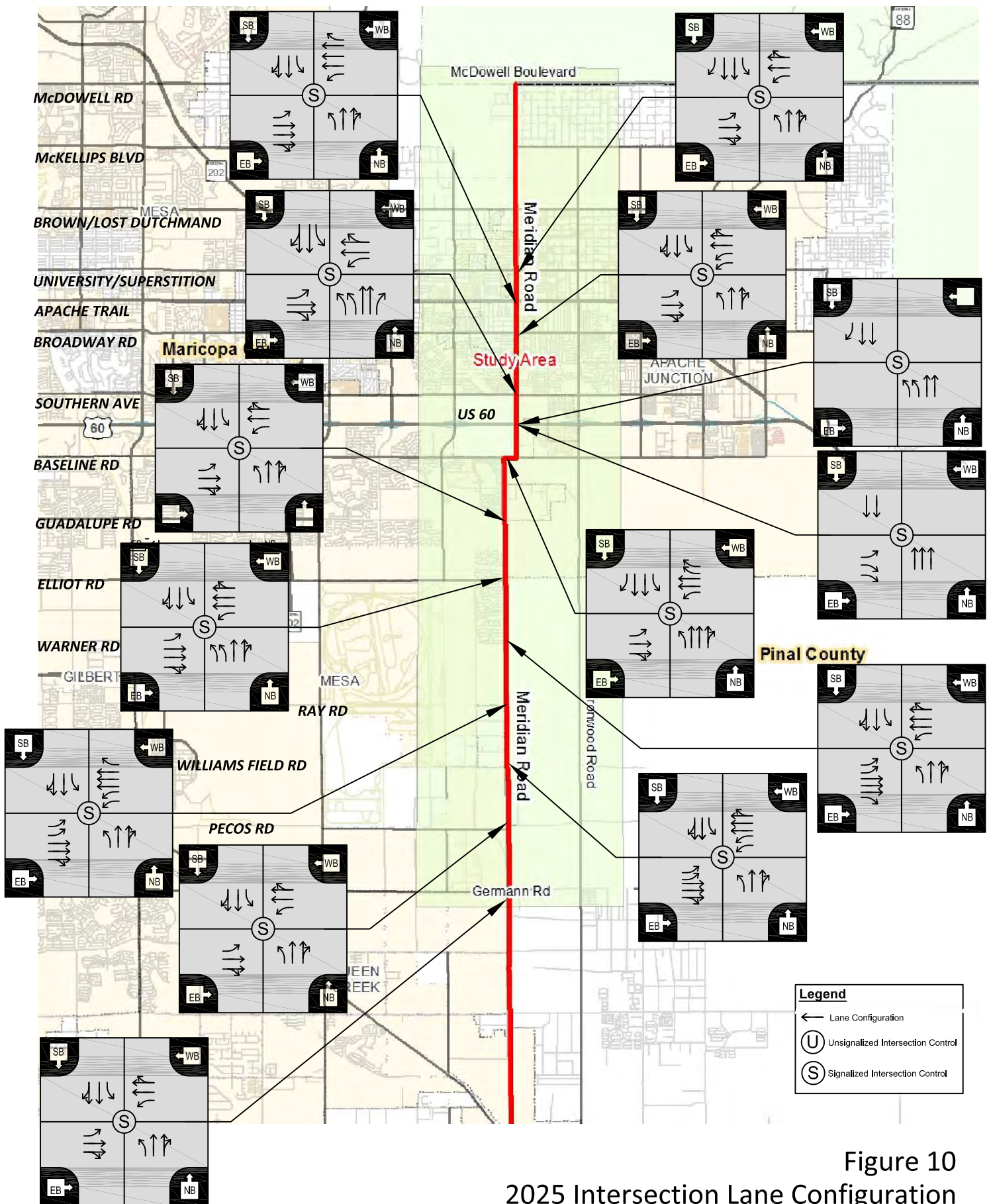

Figure 10  
2025 Intersection Lane Configuration



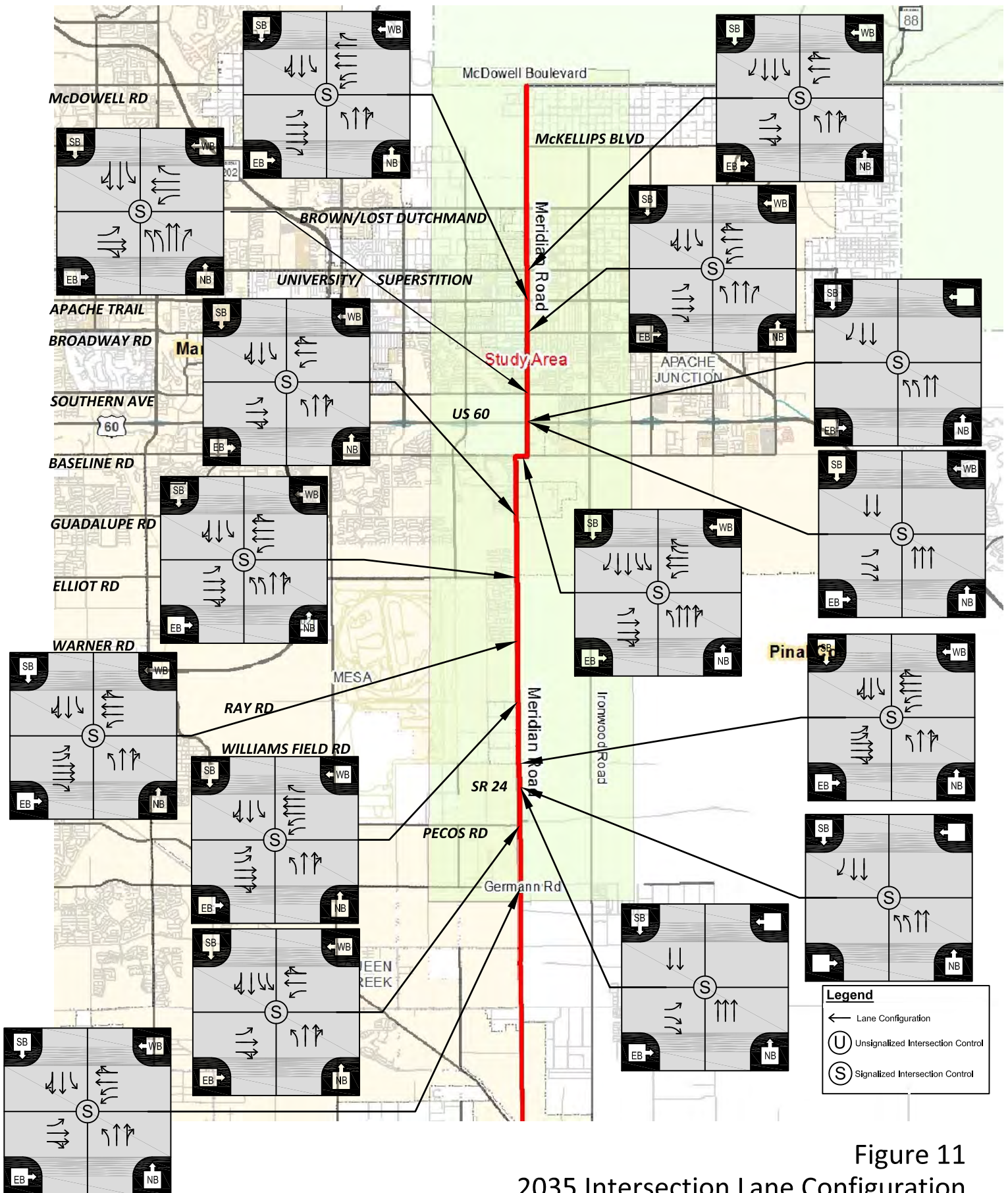

Figure 11  
2035 Intersection Lane Configuration

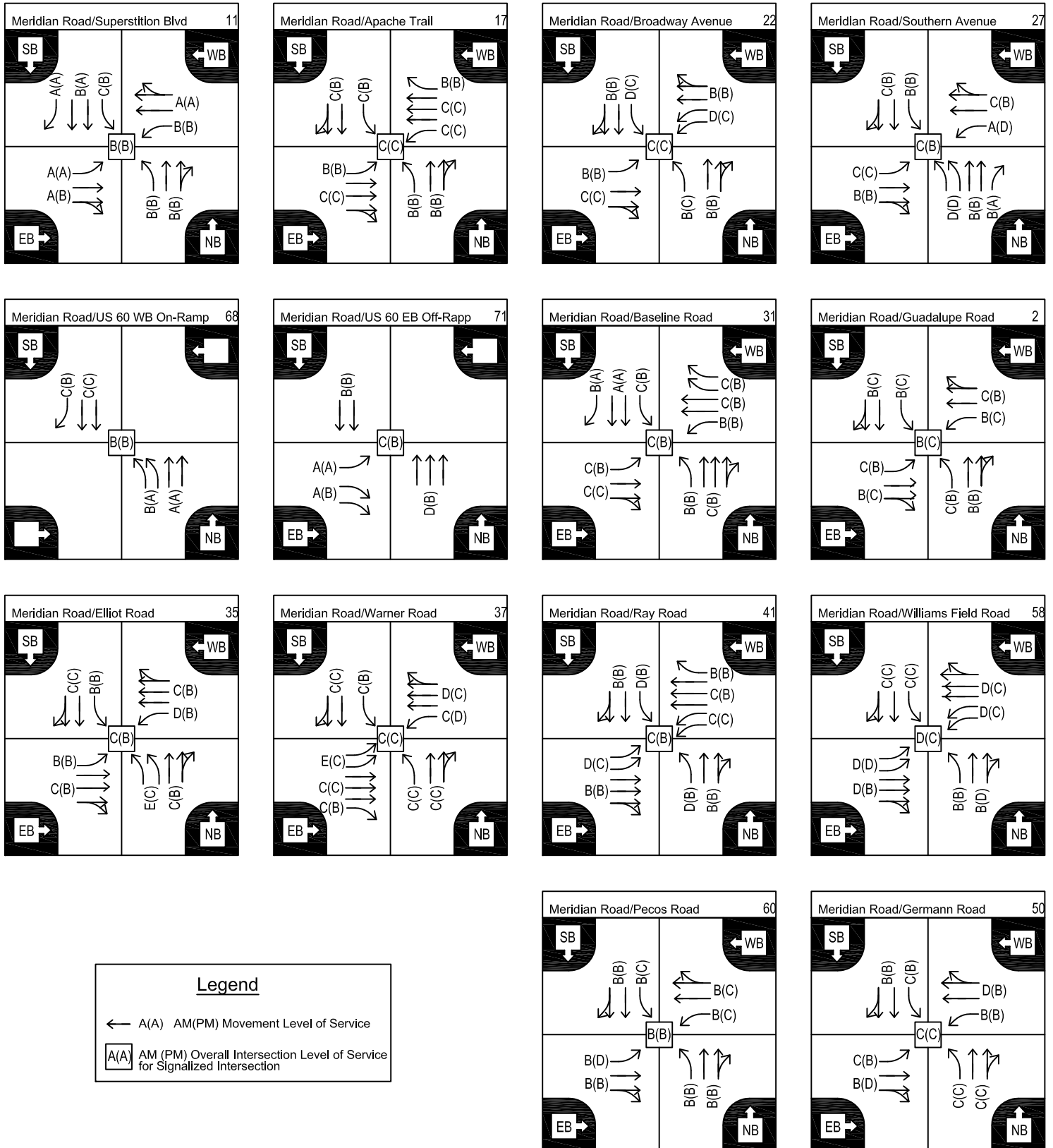
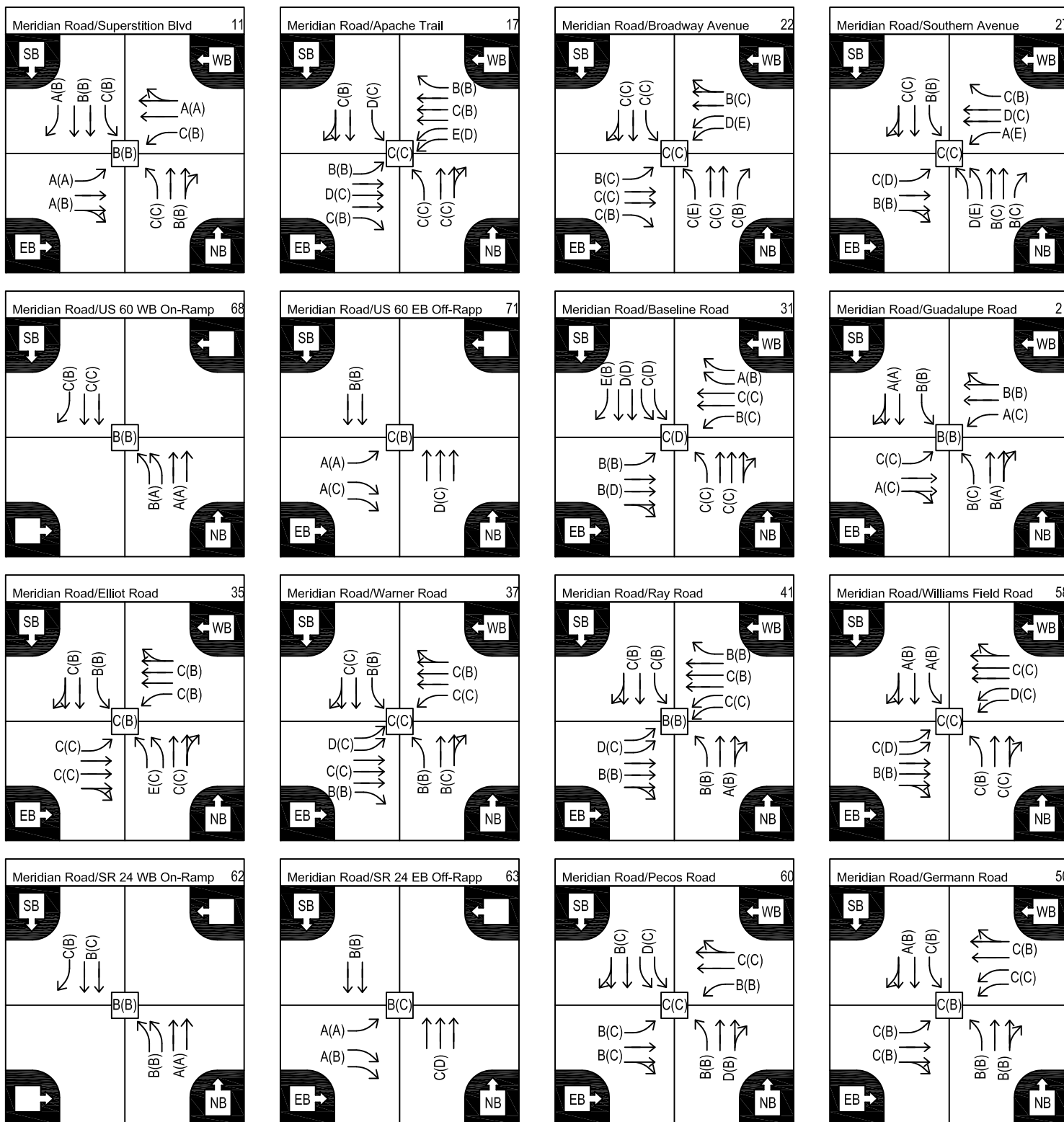

Figure 12  
2025 Intersection Level of Service





**Legend**

← A(A) AM(PM) Movement Level of Service

[A(A)] AM (PM) Overall Intersection Level of Service for Signalized Intersection

Figure 13  
2035 Intersection Level of Service

The results of the 2025 and 2035 Synchro analysis show that the typical intersection lane configuration for Meridian Road within the study area is a single left-turn and one through lane with a shared through/right-turn lane for the northbound and southbound directions. Several intersections deviate from this typical intersection lane configuration and are shown in **Table 4** and **Table 5**, respectively for 2025 and 2035.

**Table 4: 2025 Meridian Road Intersection Lane Configuration Deviations**

Meridian Road Intersection	Movement	Deviation		
		Dual Left-Turn Lanes	Exclusive Right-Turn Lane	Three Through Lanes
University Drive/ Superstition Boulevard	SB		X*	
Southern Avenue	NB	X	X	
US 60 WB On-Ramp	NB	X		
	SB		X	
US 60 EB Off-Ramp	NB			X
Baseline Road	NB			X
	SB		X	
Elliot Road	NB	X		

\*Under existing conditions

**Table 5: 2035 Meridian Road Intersection Lane Configuration Deviations**

Meridian Road Intersection	Movement	Deviation		
		Dual Left-Turn Lanes	Exclusive Right-Turn Lane	Three Through Lanes
University Drive/ Superstition Boulevard	SB		X*	
Broadway Road	NB		X	
Southern Avenue	NB	X	X	
US 60 WB On-Ramp	NB	X		
	SB		X	
US 60 EB Off-Ramp	NB			X
Baseline Road	NB			X
	SB	X	X	
Elliot Road	NB	X		
SR 24 WB On-Ramp	NB	X		
	SB		X	
SR 24 EB Off-Ramp	NB			X
Pecos Road	SB	X		

\*Under existing conditions

## IV. Development of Roadway Alternatives

### Meridian Road Alignment Alternatives

The study has been examined in two sections. The roadway alignment for the northern half of the corridor between US 60 and McDowell Boulevard forms the westerly boundary of the City of Apache Junction's roadway network. For the majority of its length Meridian Road is a two lane roadway with some widening to three and four lanes at the approach and departure of the intersections at Broadway Road, Apache Trail and Superstitions Boulevard.

The roadway alignment for the southern half of the Meridian Road corridor between Baseline Road and Germann Road is largely undefined. A two mile section from half mile north of Elliot Road to half mile south of Warner Road is a two lane street constructed west of the section line. The alignment is either a dirt track or non-existent on other sections of undeveloped land.

### Conceptual Analysis for Northern Section of Meridian Road

Concepts were developed for the northern section of the project relating to the lane configuration and right-of-way requirements. See the *Existing Right-of-Way* section for more detailed information on existing right-of-way along this section of the Meridian Road corridor. The roadway lane configuration is dealt with in the *Roadway Segment Lane Configuration* section of the report.

### Conceptual Alternatives for Southern Section of Meridian Road

Conceptual alternatives for the southern section were developed based upon identified corridor issues, the projected traffic volumes and transportation/connectivity needs. Design guidelines relating to roadway cross sections and horizontal alignment from City of Apache Junction, City of Mesa, Maricopa County Department of Transportation (MCDOT) and Pinal County were used to generate the conceptual alternatives.

#### *Alternative 1 – No Build Alternative*

The no-build alternative considers how the existing roadway network would function if the southern section of the corridor was not constructed.

#### *Alternative 2 – Section Line Alignment*

This alternative proposes to locate the corridor improvements symmetrically about the section line. It makes full use of the existing right-of-way dedicated to the west of the section line. Alternative 2 is depicted in **Figure 14**.

#### *Alternative 3 – Eastern Shift*

An easterly shift alignment is considered to minimize impacts on existing residential parcels and a drainage channel adjacent to the section line. An alignment shift of 1,100 feet to the east is proposed to line-up with the section of the Meridian Road north of Baseline Road. Alternative 3 is depicted in **Figure 14**.

### *Alternative 4 – Meandering Alignment*

The meandering alignment consists of minor shifts in the alignment either east or west of the section line to reduce impact to existing properties and use existing right-of-way. Alternative 3 is depicted in **Figure 14**.

### *Section Line Shift at Baseline Road*

Two reverse curve alignment adjustments were considered to align the off-set in the monument line that occurs at Baseline Road and are described below. The section line shift at Baseline Road alternatives are shown in **Figure 15**.

### *Alternative B1 – US 60 to Baseline Road*

With this alternative the alignment shift to the west begins just south of US 60 and ties into the monument line at Baseline Road. This alignment would require a frontage road connector to maintain access to the existing businesses on the east side of Meridian Road.

### *Alternative B2 – South of Baseline Road*

This alternative holds the Meridian Road alignment on the monument line until Baseline Road. South of Baseline Road the alignment would curve to the west to line up with the section line approximately half mile south of Baseline Road. This alignment would maintain access to Meridian Road businesses between US 60 and Baseline Road.



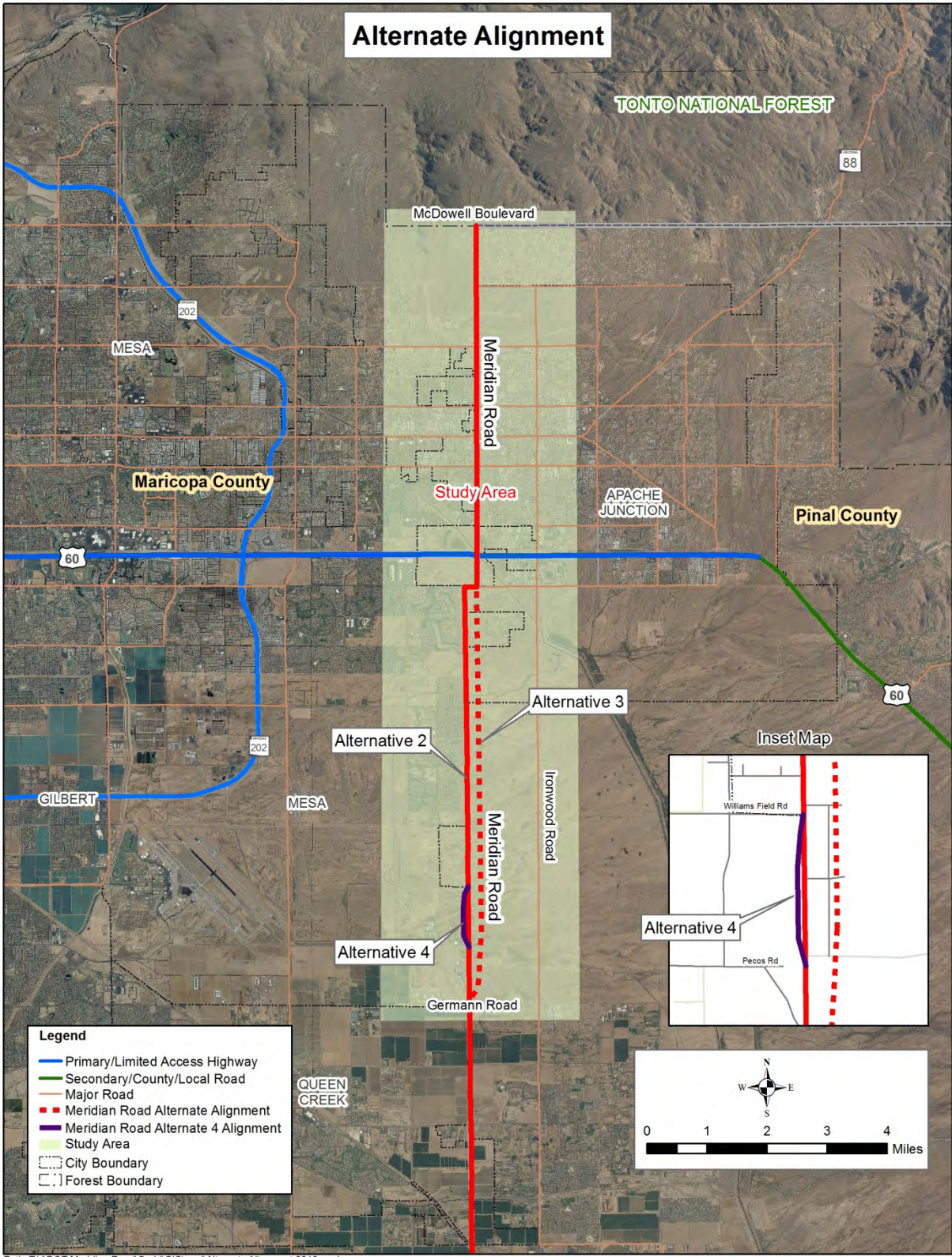

Figure 14: Conceptual Alternatives for Southern Section of Meridian Road



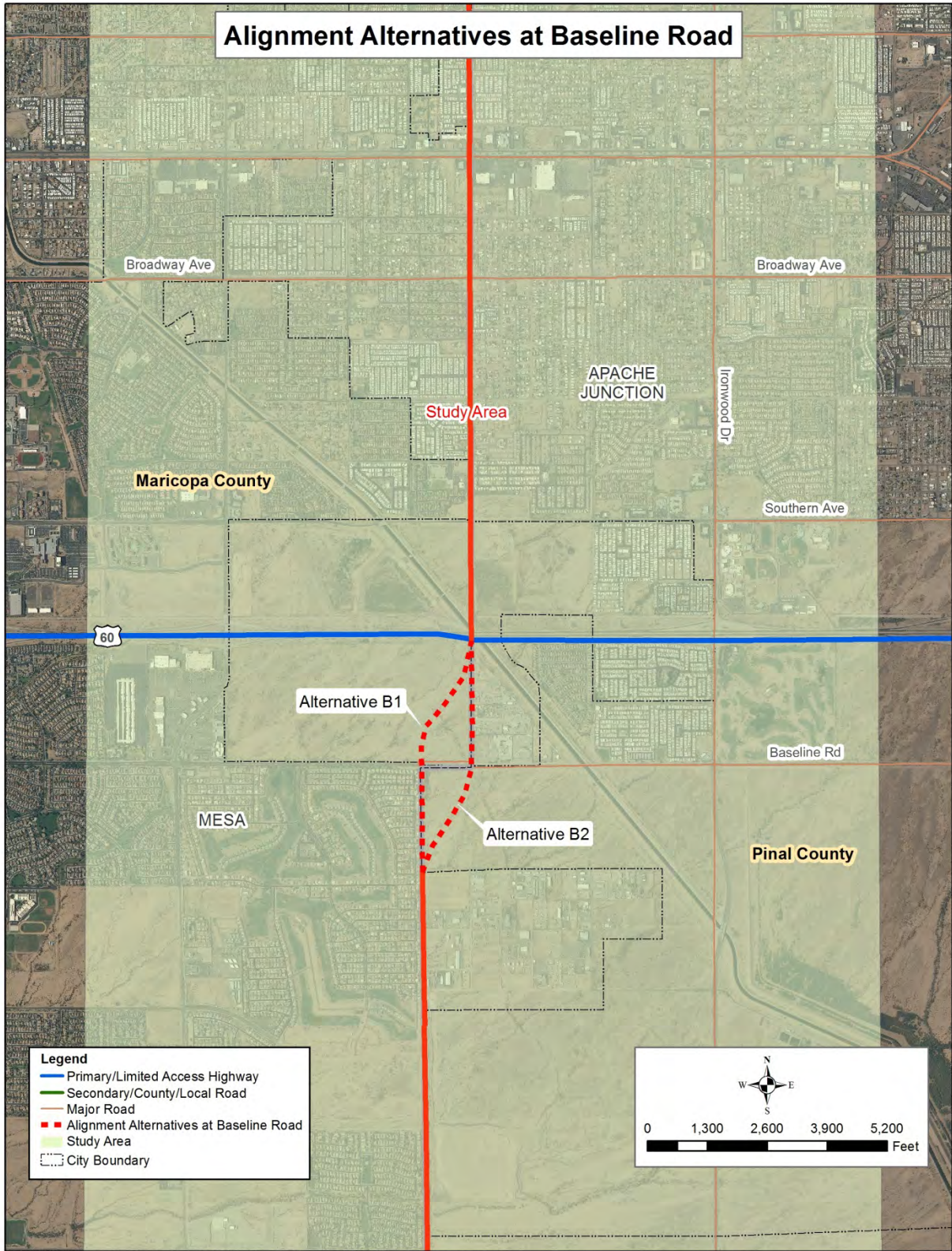

Figure 15: Section Line Shift at Baseline Road Alternatives

## V. Evaluation

### Evaluation Criteria

A preliminary matrix was developed in order to evaluate the alternatives. The evaluation criteria and corresponding questions to be addressed are as follows:

- Constructability Issues – Is the alternative constructible?
- Engineering Complexity – Does the alternative involve a more complicated design or create additional engineering challenges?
- Environmental/Cultural Issues – Is there the potential for finding historical and/or archeological artifacts? Are historic preservation activities likely required?
- Potential Utility Conflicts – Will the alternative impact existing utilities. Will new utilities be required?
- Traffic Operations – Will the alternative improve traffic flow and increase regional connectivity?
- Public Acceptability – Is the corridor alternative likely to generate negative feedback from the community?
- Socioeconomic Impacts – Does the alternative impact existing residential parcels/developments (i.e. right-of- way, or existing homes)?

The corridor alternatives were evaluated using one of three rankings based upon the perceived response for each evaluation criteria question. The three ranking levels are as follows: Minimum impact/high performance, Moderate impact/moderate performance, or High impact/low performance.

### Initial Alternative Screening

**Table 6** summarizes the results of the initial alternative screening.

**Table 6: Initial Alternative Screening Results**

Evaluation Criteria	Alternative Alternatives			
	Alt 1	Alt 2	Alt 3	Alt 4
Constructability Issues	○	○	○	○
Engineering Complexity	○	○	⊗	⊗
Environmental/Cultural Issues	○	○	○	○
Potential Utility Conflicts	○	⊗	●	⊗
Traffic Operations	●	○	○	○
Public Acceptability	●	⊗	⊗	○
Socioeconomic Impacts	○	⊗	○	⊗

○ Minimal impact/high performance

⊗ Moderate impact/performance

● High impact/low performance

### Alternative 1 – No-Build Alternative

The no-build alternative requires the least amount of design and construction, and consequently has the lowest impact to the environment, existing utilities and residential parcels. However, this alternative does not address future traffic demands or regional connectivity needs. Future residents would experience reduced safety and unacceptable capacity (i.e. Level of Service E or worse) between Lost Dutchman Boulevard and Broadway Road. **Table 7** shows the anticipated 2035 No-Build ADT and corresponding roadway segment LOS. This alternative is not recommended.

**Table 7: 2035 No-Build Average Daily Traffic and Level-of-Service**

Meridian Road Segment	2035 No Build ADT	2035 LOS
McDowell Boulevard to McKellips Boulevard	3779	A/B
McKellips Boulevard to Brown Road/Lost Dutchman Boulevard	9441	A/B
Brown Road/Lost Dutchman Boulevard to University Drive/Superstition Boulevard	16763	E/F
University Drive/Superstition Boulevard to Apache Trail	20416	E/F
Apache Trail to Broadway Road	20946	E/F
Broadway Road to Southern Avenue	15209	C
Southern Avenue to Baseline Rd	9140	A/B
Elliot Road to Warner Road	4455	A/B

### Alternative 2 – Section Line Alignment

The section line alignment is straightforward and does not present difficult or additional engineering challenges. It is the most consistent with the existing and proposed improvements from the City of Mesa, City of Apache Junction, MCDOT and Pinal County Department of Transportation. It makes full use of the existing right-of-way that has been acquired by residential developments such as Sunland Springs, Meridian Point and Mountain Ranch. This alternative distributes the right-of-way acquisition burden evenly on both sides of the section line.

The section line alignment will require right-of-way from three parcels approximately  $\frac{3}{4}$  mile south of Baseline Road. These parcels are currently occupied by light industrial businesses. An existing earth lined drainage channel currently runs along the section line between the existing residential parcels and the industrial parcels. Flow from the ditch drains into the Siphon Draw Irrigation Channel and ultimately into the Siphon Draw Detention Basin. Additional right-of-way would be required to accommodate a new channel adjacent to the roadway. South of Williams Field Road to Pecos Road, right-of-way would be required from 22 parcels, five of which contain properties. This alternative may generate negative feedback regarding these impacts to residential parcels. Overhead utilities south of Williams Field Road will likely have to be relocated. The private irrigation ditch between Pecos and Germann Roads will also need to be relocated.



### **Alternative 3 – Eastern Shift**

The main benefit of an easterly shifted alignment is the reduced impacts to the existing residential parcels along the west side of Meridian Road. It also avoids the overhead utilities and irrigation facilities along Meridian Road. However, the new alignment has substantial conflicts with existing properties and irrigation structures and would be placed solely on State Trust Land.

An easterly shift would require the acquisition of full width right-of-way to accommodate the roadway and would bisect the light industrial area south of Baseline Road. Furthermore, the alignment would also cut through the recently constructed Siphon Draw detention basin, and vacant residential parcels would need to be acquired where the alignment ties back into the section line north of German Road. Negative feedback has been received from Arizona State Land Department because of the effect on State Trust Land. They were concerned that the burden of providing right-of-way was beginning wholly placed on them. In addition, the relocation of Meridian Road off the section line would be detrimental to future property values since development patterns cannot be predicted. This alternative is not recommended.

### **Alternative 4 – Meandering Alignment**

This alternative is similar to Alternative 2, in that it basically follows the section line for most of its length. However, between Williams Field Road and Pecos Road the east right-of-way would be held and the alignment relocated up-to 15 feet west to eliminate any impact to existing residential properties. This alternative is based on the preferred alternatives recommended in the MCDOT *Meridian Road Access Management and Corridor Improvement Study*.

### **Preferred Meridian Road Alignment**

All three of the build alternatives are anticipated to have similar amount of constructability issues related to traffic control and maintenance of traffic during construction. Minimal environmental issues are anticipated with all the alternatives. Input received on the alternatives from the TAC at the meeting and a subsequent agency meeting with ASLD was generally in favor of the alignment staying on the section line because it resulted in more equitable right-of-way takes from property owners and did not place a large burden on State Trust Land. Alternative 4 was selected as the preferred alternative because it followed the section line for most of its length except the area between Williams Field Road and Pecos Road where the alignment shifted west to avoid impacting existing residential developments.

### **Preferred Section Line Shift**

Based on the input received from the TAC team and engineering considerations the preferred alternative for the two reverse curve alignments would be Alternative B1. While there was no real preferences between the alternatives from the TAC team, both were considered viable alignments, the alignment south of Baseline Road would pass through an area of land subsidence and earth fissures. In addition, consideration has to be given to the provision of a traffic interchange (TI) with US 60. Currently a half-TI consisting of a partial cloverleaf with ramps to/from the west is proposed. A new study is proposed by ADOT to investigate the provision of additional general purpose lanes along US 60. As part of this study the location of a

full interchange will be examined. Preliminary work suggest that the TI will be placed west of the existing Meridian Road bridge and probably line up with the section line south of Baseline Road.

## VI. Design Features

### Functional Classification and Typical Cross Section

In order to address the needs and purposes of the Meridian Road Corridor Study ADOT, local agencies/jurisdictions and private stakeholders reached a consensus regarding the preferred interim and ultimate facility type, and access control design elements for the corridor. During the second TAC meeting on November 13, 2012, a side-by-side comparison of each jurisdiction’s typical design criteria and development standards was carried out in order to develop a typical section for the road, as shown in **Table 8**.

**Table 8: Side-by-Side Comparison of Roadway Typical Sections**

	Apache Junction	Pinal County	Maricopa County	Mesa
Functional Classification	Principal Arterial	Major Arterial	Principal Arterial	Arterial
No. of Lanes	6	6	6	6
R.O.W. Width	150'	150'	130'	130'
Median Width	16' Raised Median	14' Raised Median	14' Raised Median	11' TWLTL 16' Raised Median
Median Lane Width	12' (Portalis)	13'	14'	11'
Width b/c – b/c	92' (Portalis)	101'	87'	up to 95'
Bike Lane Width	0'	6.5'	5.5'	4.5' - 6'
Sidewalk Width	10' (Portalis) 3' behind curb	8' 5' behind curb	5' 7' behind curb	6' 9.5' behind curb

The TAC discussed the differences between the jurisdictions’ criteria and standards and how the different jurisdictions might be able to come to a consensus on which criteria to utilize on Meridian Road. An Ultimate Roadway Cross Section was developed for Meridian Road between Southern Avenue and Germann Road providing a 6-lane roadway with a 16’ raised median, bike lanes and detached sidewalks as depicted in **Figure 16**.

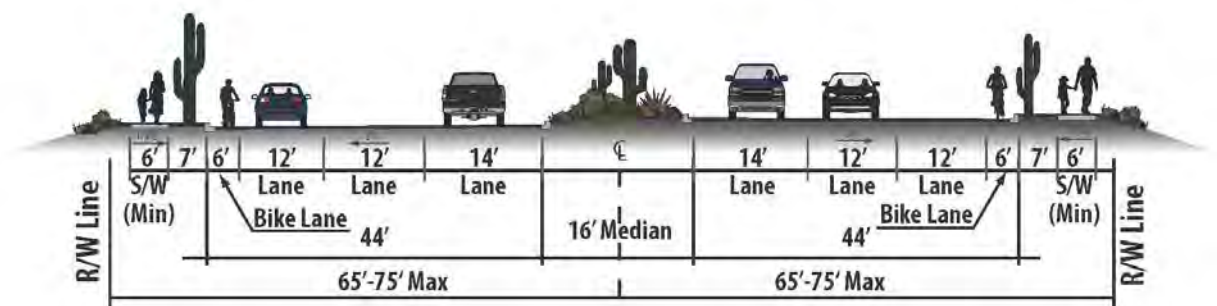

**Figure 16: Ultimate Roadway Cross Section – Southern Avenue to Germann Road**



A preferred Ultimate Roadway Cross Section was developed for Meridian Road north of Southern Avenue providing a 4-lane roadway with a 16' painted or raised median, bike lanes and detached sidewalks as depicted in **Figure 17**.

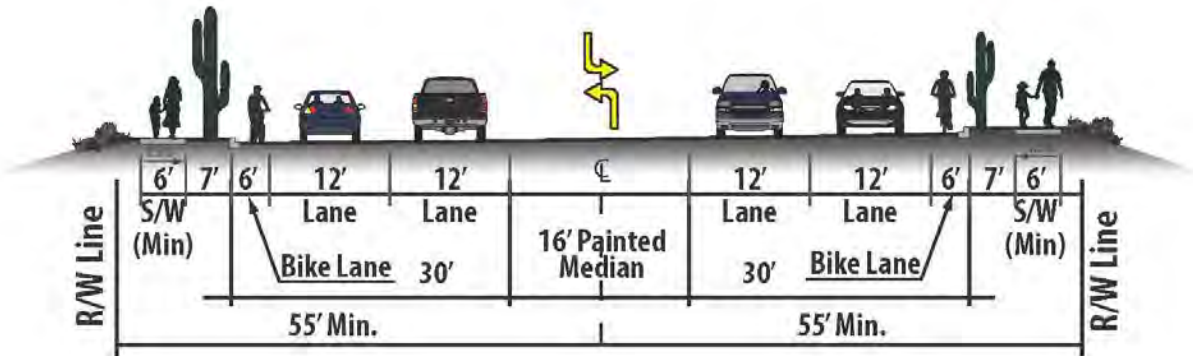

**Figure 17: Ultimate Roadway Cross Section – Lost Dutchman Boulevard to Southern Avenue**

A preferred Ultimate Roadway Cross Section was developed for Meridian Road between Lost Dutchman Boulevard and McDowell Boulevard providing a two lane road, bike lanes and detached sidewalks as depicted in **Figure 18**.

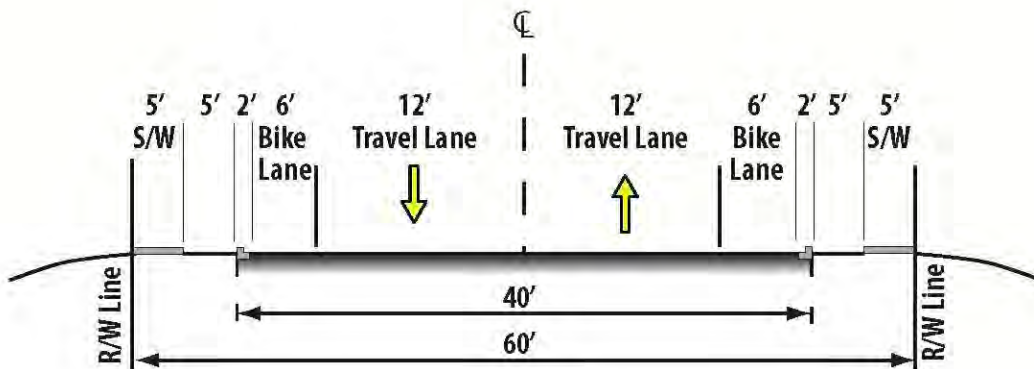

**Figure 18: Ultimate Roadway Cross Section – Lost Dutchman Boulevard to McDowell Boulevard**

**Interim Conditions**

Planning, design, and construction of the Meridian Road corridor will be driven by development of the adjacent lands. As development occurs it is anticipated that the need for the new roadway will be driven by the traffic demand associated with the trips generated. The Superstition Vistas to the east of Meridian Road will be the driving force for development along this corridor south of Baseline Road. It is difficult to determine where along the alignment the development will occur and will be very dependent on how the economy develops in the near future. While development of a funding plan is outside of the scope of this corridor feasibility study, it is possible that private developers may be able to provide a portion of the funding. It is likely that developers will required to construct a ‘half street’ adjacent to the developed land.

However, in areas of public and jurisdictional lands, public funding for right-of-way and construction may be needed.

The City of Mesa published a transportation plan in 2002 detailing their proposed street plan with suggested priorities for roadway improvements. Meridian Road was classified as a Priority 5 roadway (low priority/long rang) project at that time with improvements scheduled for 2020-2025. However, in order to fund the Light Rail Extension from Mesa Drive to Gilbert Road, Meridian Road was dropped from the MAG’s Arterial Life Cycle Program (ALCP) because the rate of growth was significantly less than predicted. Determining when roadway improvements are required often depends on how and where growth occurs along a traffic corridor. With the current economy this is unpredictable. Construction of the future SR 24 Gateway Freeway will likely serve as a catalyst to roadway improvements along Meridian Road particularly where it crosses south of Williams Field Road. The MAG Regional Transportation Plan stated that construction funding for the Maricopa County portion of the Gateway Freeway is programmed to occur in the 2016-2020 timeframe. However, funding for the design and construction of a segment of the SR 24 between the Loop 202 and Ellsworth Road was been accelerated. Construction of this segment of the freeway is currently underway and is programmed to be completed in 2013.

As previously discussed, the ultimate cross section for Meridian Road is a 6-lane divided roadway with bike lanes and detached sidewalks. However, until development and traffic volumes warrant the ultimate cross section, interim cross sections were developed based on the results of the roadway segment LOS analysis. **Figure 19** shows the recommended interim cross section for Meridian Road between McDowell Boulevard and Lost Dutchman Boulevard. **Figure 20** depicts potential interim cross section for Meridian Road between Lost Dutchman Boulevard and Germann Road. **Figure 21** depicts potential interim cross section for Meridian Road between Southern Avenue and Germann Road. The only difference between **Figure 20** and **Figure 21** between Southern Avenue and Germann Road is the median type. The median type will depend on the access control requirements developed and agreed upon by the key agencies. As traffic warrants, a second travel lane can be added in each direction to the interim cross section to obtain the ultimate cross sections.

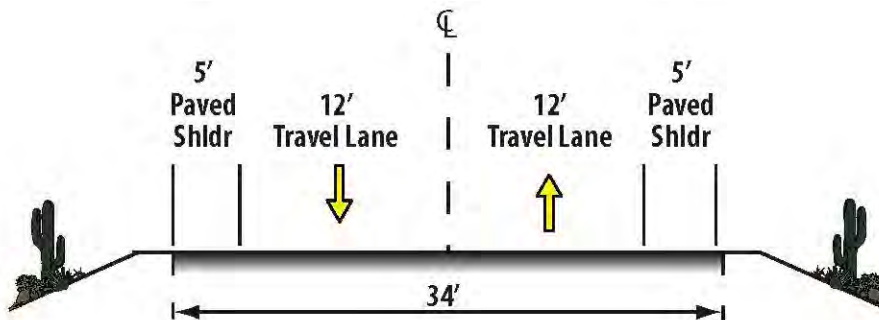

**Figure 19: Interim Cross Section: McDowell Boulevard to Lost Dutchman Boulevard**

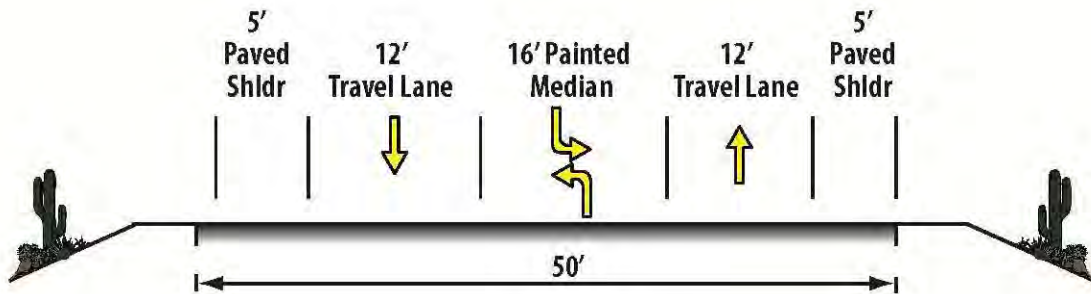

Figure 20: Interim Cross Section: Lost Dutchman Boulevard to Germann Road

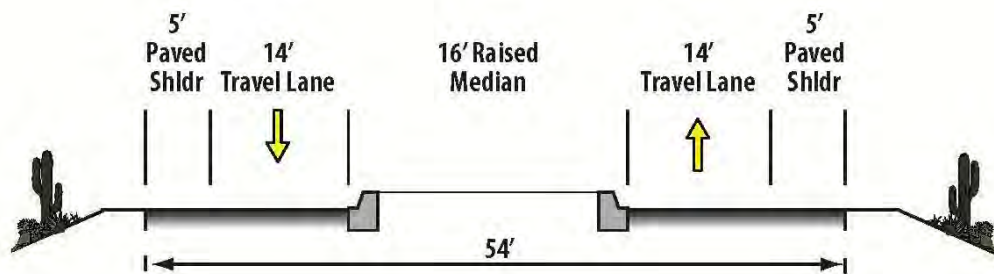

Figure 21: Interim Cross Section: Southern Avenue to Germann Road

## Phased Construction

### Near-Term Improvement Recommendations

Based on the traffic analysis results and the projected development patterns, the following improvements are either programmed or recommended for the near-term (by 2017), although the timing of these improvements will be dependent on the surrounding area development:

- The US 60/Meridian Road Traffic Interchange is programmed to be constructed by 2017.
- The Southern Avenue/Meridian Road intersection is programmed to be signalized by 2017 and widened to accommodate a left-turn lane and a shared through/right-turn lane in each direction; and
- By 2017, Meridian Road is recommended to be extended from Baseline Road to Elliot Road with intersection improvements at Baseline Road, Guadalupe Road and Elliot Road to improve connectivity within the corridor with the addition of programmed improvements.

### Mid-Term Improvement Recommendations

Based on the development pattern projected by the MAG, the following improvements are anticipated to occur in the mid-term (2017-2025), although the timing of these improvements will be dependent on the surrounding area development:

- Meridian Road is anticipated to be widened to a three-lane roadway from Lost Dutchman Boulevard to Southern Avenue;

- Meridian Road is anticipated to be widened to a four-lane divided roadway from Southern Avenue to Elliot Road; and
- Meridian Road is anticipated to be extended from Warner Road to Germann Road as a four-lane divided roadway by 2025 including constructing Meridian Road intersections with Ray Road, Williams Field Road, Pecos Road and Germann Road as well as the SR 24/Meridian Road Traffic Interchange.

With the gaps that currently exist in Meridian Road likely to be filled during the mid-term timeframe, this will result in a continuous arterial with freeway access to US 60. These improvements are anticipated to significantly alter traffic volumes on Meridian Road as well as along some of the adjacent parallel arterials, such as Ironwood Road.

### **Long-Term Improvement Recommendations**

Based on the development pattern projected by the MAG, the following improvements are anticipated to occur in the mid-term (2025-2035), although the timing of these improvements will be dependent on the surrounding area development:

- Meridian Road is anticipated to be widened to a four-lane roadway from Lost Dutchman Boulevard to Southern Avenue; and
- The SR 24/Meridian Road Traffic Interchange is anticipated to be constructed by 2035.

### **Ultimate Improvement Recommendations**

Based on the recommendations from local and regional transportation plans, the following improvement is anticipated to occur in the ultimate condition (beyond 2035), although the timing of these improvements will be dependent on the surrounding area development:

- Meridian Road is anticipated to be widened to the full six-lane cross-section between Southern Avenue and Germann Road.

### **Existing Right-of-Way**

The existing right-of-way does not consistently accommodate the typical right-of-way requirements for the desired arterial cross section. Existing right-of-way conditions can generally be characterized as follows and is illustrated in **Table 9**:

- *McDowell Boulevard to Baseline Road* – The existing right-of-way through this segment is primarily 33 feet or 50 feet either side of the section line. Research was carried out by David Evans and Associates, Inc. for the City of Apache Junction which indicated that for some sections of the roadway there was documentation demonstrating that right-of-way had not been preserved. We have assumed that full right-of-way is required in these areas however; further investigation should be carried out to verify this.
- *Baseline Road to Germann Road* – The existing right-of-way through this section is primarily 65 feet to the west of the section line (Maricopa County) with small sections of 55 feet. To the east of the section line (Pinal County) the area is undeveloped State Trust Land and no right-of-way has been preserved at this stage.

### Required Right-of-Way

**Table 10** illustrates the required right-of-way in addition to what is already provided based on the following assumptions:

- *McDowell Boulevard to Lost Dutchman Road* – Two-lane road with 40 feet of right-of-way;
- *Lost Dutchman Road to Southern Avenue* – Four-lane arterial street with 110 feet of right-of-way; and
- *Southern Avenue to Germann Road* – Six-lane arterial street with 130 feet of right-of-way.



**Table 9: Existing Right-of-Way**

Meridian Road Segments		Existing ROW Width		Existing Pavement Width
From	To	West of Centerline (MCDOT)	East of Centerline (MCDOT & PCDOT)	
McDowell Blvd	McKellips Boulevard	●40' North of Canyon St ●55' South of Canyon St	N/A	●24'
McKellips Boulevard	Lost Dutchman Road	●55' from 1/2 mile south of McKellips Blvd to Lost Dutchman	N/A	●24'
Lost Dutchman Road	Superstition Boulevard	●33' North of Windsong St ●33' South of Windsong St ●55' South of Smoke Tree St ●65' South of Silverado Estates	●50' between Lost Dutchman Rd and Concho Street ●33' between Concho Street and Tepee St ●50' between Tepee St and Shiprock St ●33' between Shiprock St and Silverado Estates ●50' between Silverado Estates and Superstition Boulevard	●24' ●40' ●45' ●45' ●76'
Superstition Boulevard	Apache Trail	●55'	●50' for a 300' segment south of Superstition Boulevard ●None from 300' south of Superstition Boulevard to Gregory Street ●50' from Gregory St to Apache Trail	●62' ●24' ●62' at intersection
Apache Trail	Broadway Avenue	●Undefined from Apache Trail to 4th Street ●55' from 4th St to 220' north of Broadway Road ●40' from 220' north of Broadway Rd to Broadway Rd	●40'	●65' ●26' ●65' at intersection
Broadway Avenue	Southern Avenue	●65' North of Wier Ave ●0' South of Wier Ave to Pueblo Ave ●55' from Pueblo Ave to Southern Ave	●0' Broadway Ave to 9th place ●50' from 9th place to 16th Avenue ●33' from 16th Avenue for 1/4 mile ●50' from 1/4 mile south of 16th Street to Southern Avenue	●26' ●widens at intersection
Southern Avenue	Baseline Road	●55'	●50'	●26'
Baseline Road	Guadalupe Road	●65'	N/A	●No Pavement
Guadalupe Road	Elliot Road	●55' for 1/2 mile south of Guadalupe ●65' for 1/2 mile north of Elliot	N/A	●No Pavement
Elliot Road	Warner Road	●65' north of Mesquite St ●55' south of Mesquite St ●65' from 200' north of Renfield Ave ●70' from 600' north of Warner Road	N/A	●36'
Warner Road	Ray Road	●55' to north of Starkey Ave ●65' South of Starkey Ave to 545' north of Ray Rd ●75' from 545' north of Ray Rd to Ray Road	N/A	●32' ●No Pavement ●No Pavement
Ray Road	Williams Field Road	●65'	N/A	●No Pavement
Williams Field Road	Pecos Road	●55'	N/A	●No Pavement
Pecos Road	Germann Road	●65' from Pecos Road to 565' north of Germann Road ●75' for a 565' segment north of Germann Road	N/A	●No Pavement

**Table 10: Right-of-Way Requirement**

Meridian Road Segments		ROW Width Required		Required Pavement Width
From	To	West of Centerline (MCDOT)	East of Centerline (PCDOT)	
McDowell Road	McKellips Boulevard	●None	●40'	●40'
McKellips Boulevard	Lost Dutchman Road	●None from McKellips to 1/2 mile south ●40' from 1/2 mile south of McKellips Blvd to Lost Dutchman	●40'	●40'
Lost Dutchman Road	Superstition Boulevard	●22' North of Smoketree Steet ●None South of Smoketree Street	●5' between Lost Dutchman Rd and Concho Street	●76'
			●22' between Concho Street and Tepee St	●72'
			●5' between Tepee St and Shiprock St	●72'
			●22' between Shiprock St and Silverado Estates	●72'
			●5' between Silverado Estates and Superstition Boulevard	●72'
Superstition Boulevard	Apache Trail	●None to 350' north of Apache Trail ●55' for 350' north of Apache Trail	●5' for a 300' segment south of Superstition Boulevard ●55' from 300' south of Superstition Boulevard to Gregory Street ●55' from Gregory St to Apache Trail	●76' ●76' ●76'
Apache Trail	Broadway Avenue	●55' from Apache Trail to 4th Street ●None from 4th St to 220' north of Broadway Road ●10' from 220' north of Broadway Rd to Broadway Rd	●15'	●76' ●76' ●76'
Broadway Avenue	Southern Avenue	●None North of Wier Ave ●55' South of Wier Ave to Puelo Ave ●None between Pueblo Ave to Southern Ave	●55' Broadway Ave to 9th place ●5' from 9th Place to 16th Avenue ●22' from 16th Avenue for 1/4 mile ●5' from 1/4 mile south of 16th Street to Southern Avenue	●76'
Southern Avenue	Baseline Road	●10'	●15'	●104'
Baseline Road	Guadalupe Road	●None	●65'	●104'
Guadalupe Road	Elliot Road	●None except for a 1/2 mile section south of Guadalupe Road where 10' is required	●65'	●104'
Elliot Road	Warner Road	●None except for a 1/4 mile section south of Mesquite St where 10' is required	●65'	●104'
Warner Road	Ray Road	●10' from Warner Rd to Starkey Ave ●None from Starke Ave to Ray Rd	●65'	●104'
Ray Road	Williams Field Road	●None	●65'	●104'
Williams Field Road	Pecos Road	●10'	●65'	●104'
Pecos Road	Germann Road	●None	●65'	●104'

**Cost Estimate**

Preliminary cost estimates for roadway construction and right-of-way acquisition were prepared for the corridor alternatives. This section summarizes the cost estimate for the recommended alternative, and the methodology used to develop the order of magnitude estimate. **Table 11** presents the order of magnitude cost estimate for the northern section of the corridor plus the alternatives for the southern section of the corridor. Detailed estimates for the corridor alternative may be found in **Appendix C**.

Table 11: Summary of Corridor Segment Estimates

Phased Construction	Northern Section	Southern Section Alternatives			
		Alternative 1	Alternative 2	Alternative 3	Alternative 4
Near-Term	\$ -	\$ -	\$5,210,947	\$5,210,947	\$5,210,947
Mid/Long-Term	\$20,344,040	\$ -	\$25,613,040	\$28,956,720	\$25,613,040
Ultimate	\$ -	\$ -	\$11,394,480	\$12,524,640	\$11,394,480
<b>Total Cost (Northern plus Southern)</b>	<b>\$ -</b>	<b>\$ -</b>	<b>\$62,562,507</b>	<b>\$67,036,347</b>	<b>\$62,562,507</b>

The methodologies used to determine the quantity and costs for each item listed in the estimate are described below:

- Pavement – New pavement quantities were determined by multiplying the pavement width from the typical cross section of the proposed roadway by the total length of the corridor segment. The unit of measurement is square yards and the costs are based on recent ADOT construction bids.
- Earthwork and Drainage - A vertical alignment was not developed for the corridor with this study. Consequently, cost estimates for earthwork are based on length of roadway and anticipated terrain characteristics. The cost for Earthwork and Drainage were based on similar projects with a profile designed at or near existing grade. Earthwork percentage was 25% of new pavement costs while 15% of the new pavement costs were used to estimate Drainage costs.
- Structures – Based on size of structure needed to cross Powerline Floodway.
- Maintenance of Traffic, Lighting, Signing, Signals, Utilities, & Incidental Work – Costs for these items were based on a percentage of the subtotal generated from the items listed above.
- Right-of-Way Acquisition – Right-of-way costs of \$20,000 per acre (based on costs used in the *Signal Butte Corridor Improvement Study*, *Elliot Road Corridor Improvement Study* and *Meridian Road Access Control and Corridor Improvement Study*).
- Design and Construction Management – An estimate of 25 percent was used which include design and construction management.
- Contingency - An estimate of 25 percent of the total costs, including right-of-way acquisition, was used given the macro scale design effort of this corridor study.

**Table 12** presents the itemized cost estimate for the near-term improvements of the Meridian Road Corridor. **Table 13** and **Table 14** presents the itemized cost estimate for the northern segment of the Meridian Road Corridor between McDowell Boulevard and Southern Avenue for under the mid-term and long-term recommendations, respectively. **Table 15** and **Table 16** present the itemized cost estimate for the southern segment's preferred Meridian Road Corridor between Southern Avenue and Germann Road under the mid/long-term and ultimate recommendations, respectively. The near-term, mid-term, long-term and ultimate phasing recommendations are described in further detail under section *Phased Construction*.

Table 12: Itemized Cost Estimate for Near-Term Recommendations

Item	Item Description	Unit	Unit Price	Quantity	Total
-	(Segment Length)	MILES	-	2	-
1	New Pavement	SY	\$32.00	46934	\$1,501,888
2	Earthwork	LSUM	N/A	25% of Item 1	\$375,472
3	Drainage	LSUM	N/A	15% of Item 1	\$225,283
4	Structures	LSUM	\$500,000.00	0	\$ -
5	Maintenance of Traffic	LSUM	N/A	10% of Items 1-3	\$210,264
6	Lighting	LSUM	N/A	5% of Items 1-3	\$105,132
7	Signing/Signals	LSUM	N/A	15% of Items 1-3	\$315,396
8	Utilities	LSUM	N/A	5% of Items 1-3	\$105,132
9	Incidental Work	LSUM	N/A	15% of Items 1-3	\$315,396
<b>Total Construction Cost =</b>					<b>\$3,153,965</b>
10	ROW Acquisition	ACRE	\$20,000.00	16	\$320,000
11	Design & Construction Management	LSUM	N/A	25% of Item 1-10	\$868,491
12	Contingency	LSUM	N/A	25% of Item 1-10	\$868,491
<b>Order of Magnitude Project Cost =</b>					<b>\$5,210,947</b>

\* Cost excludes Meridian Road TI and Southern Avenue intersection improvements

**Table 13: Itemized Cost Estimate for the Northern Segment under Mid-Term Recommendations:  
McDowell Boulevard to Southern Avenue**

Item	Item Description	Unit	Unit Price	Quantity	Total
-	(Segment Length)	MILES	-	5.5	-
1	New Pavement	SY	\$32.00	129067	\$4,130,144
2	Earthwork	LSUM	N/A	5% of Item 1	\$206,507
3	Drainage	LSUM	N/A	15% of Item 1	\$619,522
4	Structures	LSUM	\$500,000.00	0	\$ -
5	Maintenance of Traffic	LSUM	N/A	10% of Items 1-3	\$495,617
6	Lighting	LSUM	N/A	1% of Items 1-3	\$49,562
7	Signing/Signals	LSUM	N/A	10% of Items 1-3	\$495,617
8	Utilities	LSUM	N/A	15% of Items 1-3	\$743,426
9	Incidental Work	LSUM	N/A	15% of Items 1-3	\$743,426
<b>Total Construction Cost =</b>					<b>\$7,483,821</b>
10	ROW Acquisition	ACRE	\$20,000.00	25	\$500,000
11	Design & Construction Management	LSUM	N/A	25% of Item 1-10	\$1,995,955
12	Contingency	LSUM	N/A	25% of Item 1-10	\$1,995,955
<b>Order of Magnitude Project Cost =</b>					<b>\$11,975,731</b>

**Table 14: Itemized Cost Estimate for the Northern Segment under Long-Term Recommendations:  
McDowell Boulevard to Southern Avenue**

Item	Item Description	Unit	Unit Price	Quantity	Total
-	(Segment Length)	MILES	-	5.5	-
1	New Pavement	SY	\$32.00	96214	\$3,078,848
2	Earthwork	LSUM	N/A	5% of Item 1	\$153,942
3	Drainage	LSUM	N/A	15% of Item 1	\$461,827
4	Structures	LSUM	\$500,000.00	0	\$ -
5	Maintenance of Traffic	LSUM	N/A	10% of Items 1-3	\$369,462
6	Lighting	LSUM	N/A	1% of Items 1-3	\$36,946
7	Signing/Signals	LSUM	N/A	10% of Items 1-3	\$369,462
8	Utilities	LSUM	N/A	15% of Items 1-3	\$554,193
9	Incidental Work	LSUM	N/A	15% of Items 1-3	\$554,193
<b>Total Construction Cost =</b>					<b>\$5,578,873</b>
10	ROW Acquisition	ACRE	\$20,000.00	0	\$ -
11	Design & Construction Management	LSUM	N/A	25% of Item 1-10	\$1,394,718
12	Contingency	LSUM	N/A	25% of Item 1-10	\$1,394,718
<b>Order of Magnitude Project Cost =</b>					<b>\$8,368,309</b>

**Table 15: Itemized Cost Estimate for the Preferred Corridor under Mid/Long-Term Recommendations:  
Southern Avenue to Germann Road**

Item	Item Description	Unit	Unit Price	Quantity	Total
-	(Segment Length)	MILES	-	7.5	-
1	New Pavement	SY	\$32.00	228800	\$7,321,600
2	Earthwork	LSUM	N/A	25% of Item 1	\$1,830,400
3	Drainage	LSUM	N/A	15% of Item 1	\$1,098,240
4	Structures	LSUM	\$500,000.00	1	\$500,000
5	Maintenance of Traffic	LSUM	N/A	10% of Items 1-3	\$1,025,024
6	Lighting	LSUM	N/A	5% of Items 1-3	\$512,512
7	Signing/Signals	LSUM	N/A	15% of Items 1-3	\$1,537,536
8	Utilities	LSUM	N/A	5% of Items 1-3	\$512,512
9	Incidental Work	LSUM	N/A	15% of Items 1-3	\$1,537,536
<b>Total Construction Cost =</b>					<b>\$15,875,360</b>
10	ROW Acquisition	ACRE	\$20,000.00	60	\$1,200,000
11	Design & Construction Management	LSUM	N/A	25% of Item 1-10	\$4,268,840
12	Contingency	LSUM	N/A	25% of Item 1-10	\$4,268,840
<b>Order of Magnitude Project Cost =</b>					<b>\$25,613,040</b>



**Table 16: Itemized Cost Estimate for the Preferred Corridor under Ultimate Recommendations:  
Southern Avenue to Germann Road**

Item	Item Description	Unit	Unit Price	Quantity	Total
-	(Segment Length)	MILES	-	7.5	-
1	New Pavement	SY	\$32.00	105600	\$3,379,200
2	Earthwork	LSUM	N/A	25% of Item 1	\$844,800
3	Drainage	LSUM	N/A	15% of Item 1	\$506,880
4	Structures	LSUM	\$500,000.00	1	\$500,000
5	Maintenance of Traffic	LSUM	N/A	10% of Items 1-3	\$473,088
6	Lighting	LSUM	N/A	5% of Items 1-3	\$236,544
7	Signing/Signals	LSUM	N/A	15% of Items 1-3	\$709,632
8	Utilities	LSUM	N/A	5% of Items 1-3	\$236,544
9	Incidental Work	LSUM	N/A	15% of Items 1-3	\$709,632
<b>Total Construction Cost =</b>					<b>\$7,596,320</b>
10	ROW Acquisition	ACRE	\$20,000.00	0	\$ -
11	Design & Construction Management	LSUM	N/A	25% of Item 1-10	\$1,899,080
12	Contingency	LSUM	N/A	25% of Item 1-10	\$1,899,080
<b>Order of Magnitude Project Cost =</b>					<b>\$11,394,480</b>

### East Mesa Area Drainage Master Plan (ADMP)

The East Mesa Area Drainage Master Plan (ADMP) Update was initiated in spring 2012 and will be completed in fall 2013. The ADMP Update has identified the need for a drainage facility along the Meridian Road alignment (from Powerline Floodway to Queen Creek Road) to intercept runoff from Pinal County. The preliminary estimates for the right-of-way required for the earthen channel (and associated aesthetic features) ranges from 102' – 144'. The proposed channel is sized for the 100-year event. The draft preferred location for the channel (as of May 2013) is adjacent to the east right-of-way line of the Meridian Road alignment. The ADMP project area is shown in **Figure 22**.

Existing right-of-way has been secured along portions of the Maricopa County side of Meridian Road section line. This right-of-way would be sufficient for the future road but additional land will be required for the combined roadway and channel. To the east of the section line there is vacant land which is held in trust and is administered by ASLD.

Based on the typical roadway and channel cross sections for Meridian Road, the overall combined roadway and channel width along Meridian Road would be relatively high (approximately 260 feet) due to the inclusion of landscaping and other aesthetic treatments. ASLD would seek to achieve a balance between aesthetics enhancements with associated greater land requirements and straight, narrow channels with minimal aesthetics.

The current policy when right-of-way is required along State Trust Land is to share the burden equally with adjacent landowners. Extenuating circumstances, e.g., the desire to avoid condemnation proceedings against existing developments may warrant a deviation from the current policy, but such deviation would require careful study.

Discussions were held with ASLD and other local agencies regarding the coordination of the two facilities and where best to place the roadway and channel.

- Placing the channel adjacent to the roadway similar to Indian Bend Wash in Scottsdale, AZ;
- Detaching the channel upstream of the roadway behind future development to be possibly used as an open space facility similar to DC Ranch in Scottsdale, AZ; and
- Relocate both the roadway and the channel east about 1,100 feet to line up with the north section line of Meridian Road, similar to Indian Bend Wash in Scottsdale, AZ.

ASLD had concerns about future development on State Trust Land. Since development patterns cannot be predicted, the construction of a channel or roadway that deviates from the section line could reduce rather than enhance property values when land is offered for sale.

Consensus was reached that the roadway would stay on the section line even though the location of the flood control facility has yet to be determined at this time. Maricopa County Flood Control District is continuing discussions with ASLD and Pinal County Flood Control District. It was concluded that the combined footprint of the channel and the roadway should be refined/reduced as much as possible if this was the alternative carried forward. Shared right of way for multi-use pathway is an option to consider. Each facility would independently provide sidewalks or pathways and the contiguous facilities could share that amenity thus reducing the total right of way requirements. **Figure 23** depicts a possible cross section for the combined roadway and channel.

The flood control study is due to be completed in the summer 2013. At such time selected alternatives will be presented following further discussions with stakeholder and the public.



# EAST MESA AREA DRAINAGE MASTER PLAN UPDATE Project Area

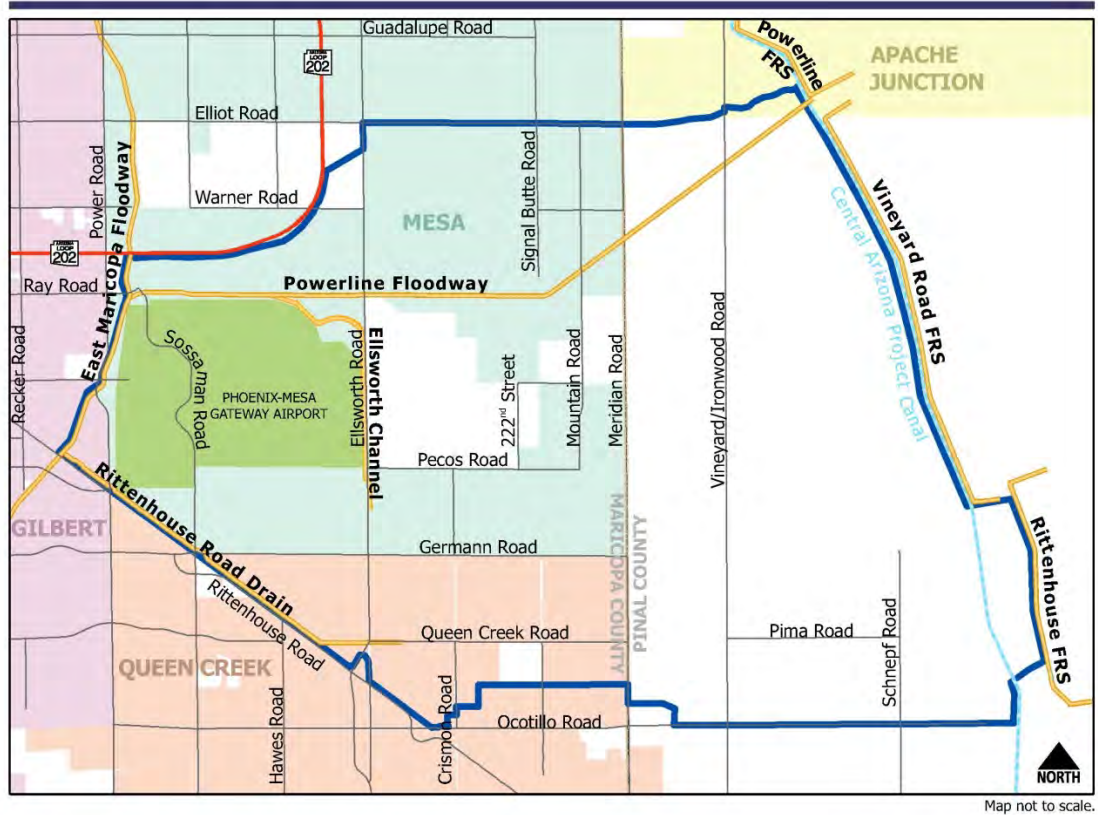

2801 West Durango Street, Phoenix, Arizona 85009, 602-506-1501

www.fcd.maricopa.gov

Figure 22: East Mesa ADMP Alternative Overview

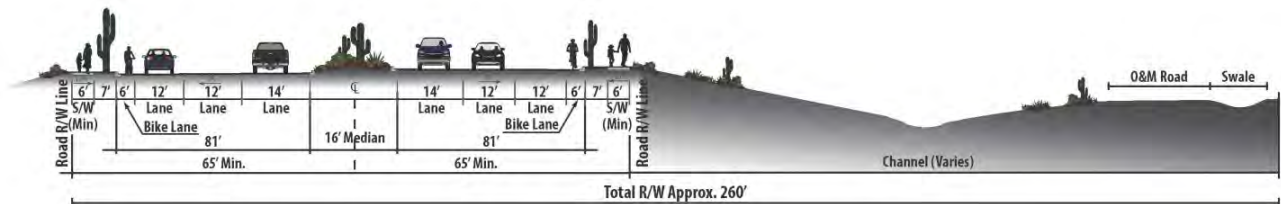
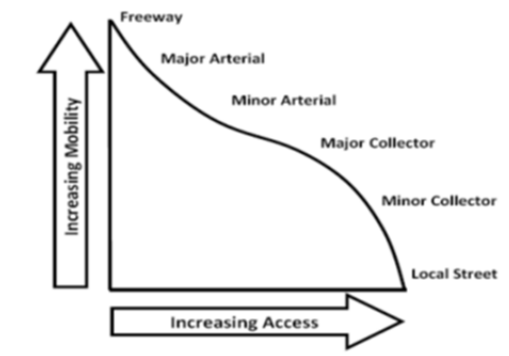

Figure 23: Roadway/Channel Combined Cross Section

## Access Management

The efficiency and safety of a street is dependent on the number and type of obstructions affecting vehicles moving along the facility. Side friction are caused on most streets by vehicles entering, leaving or crossing the road at intersecting streets and driveways. Effective access management programs control the number of driveways and vehicular curb cuts, remove slower turning vehicles, and reduce the number of vehicular conflict points. In order to assure the best overall use of the facility by the public, it is necessary to regulate vehicle movements in and out of adjoining developments and cross streets. Controlling access improves mobility and is linked to the function of a particular roadway. Low volume, low speed facilities (such as local roads) serve to provide direct and frequent access to properties. Roadways with higher speeds and higher traffic volumes serve to provide mobility and restrict direct access to adjacent land uses, such as freeways which are completely access controlled. The amount of appropriate access is related to the level of mobility and specific function of a road as illustrated in **Figure 24**.



**Figure 24: Access versus Mobility for a Given Roadway**

According to the Federal Highway Administration (FHWA) Access Management Web site ([http://ops.fhwa.dot.gov/access\\_mgmt/index.htm](http://ops.fhwa.dot.gov/access_mgmt/index.htm)), “access management” is the proactive management of vehicular access points to land parcels adjacent to all manner of roadways. The FHWA identifies five key techniques that state and local governments can use to control access to highways, major arterials, and other roadways:

- *Access Spacing*: increasing the distance between traffic signals improves the flow of traffic on major arterials, reduces congestion, and improves air quality for heavily traveled corridors.
- *Driveway Spacing*: fewer driveways spaced further apart allow for more orderly merging of traffic and presents fewer challenges to drivers.
- *Safe Turning Lanes*: dedicated left- and right-turn, indirect left-turns and U-turns, and roundabouts keep through-traffic flowing. Roundabouts present an opportunity to reduce an intersection with many conflict points or a severe crash history (T-bone crashes) to one that operates with fewer conflict points and less severe crashes (sideswipes) if they occur.
- *Median Treatments*: two-way left-turn lanes (TWLTL) and non-traversable, raised medians are examples of some of the most effective means to regulate access and reduce crashes.

- *Right-of-Way Management*: as it pertains to right-of-way preservation for future widening, good sight distance, access location, and other access-related issues.

The result of combining all these techniques of best practices of access management has benefits for motorists, bicyclists, pedestrians, transit riders, business people, government agencies, and communities. The desired outcomes of access management are highways that:

- Are safer for vehicular, pedestrian traffic and bicycle safety;
- Increase roadway capacity;
- Allow motorists to operate vehicles with fewer delays, less fuel consumption, and fewer emissions;
- Provide reasonable access to properties;
- Maintain their functional integrity and efficiency, helping to protect the investment of taxpayer dollars;
- Improve customer safety and convenience, providing more efficient freight movement, and raising property values;
- Reflect coordination between land use and transportation decisions; and
- Are used for the purposes (functions) for which they are designed.

### Access Management Recommendations

Access management guidelines from the various agencies were reviewed to establish the access management strategy for the Meridian Road Corridor. This can be accomplished by establishing a program of legal, administrative, and technical strategies with the appropriate balance between property access and the need to control access to serve public need. Ideally, these strategies will be implemented through planning practices, rules, engineering standards, and procedures resulting in access decisions that successfully, fairly, and consistently determine access management for each unique situation. **Table 17** summarizes the access control within the study corridor.



Table 17: Access Control Guidelines per Jurisdiction (for Urban Arterial Roads)

Access Control Feature	Pinal County	City of Mesa	City of Apache Junction	MCDOT
Medians	Divided with full or directional median openings at ¼ mile spacing	Divided with full or directional median openings at ¼ mile spacing	Divided with full or directional median openings at ¼ mile spacing	Divided with full or directional median openings at ¼ mile spacing
Traffic Signal Spacing	¼ mile and ½ mile locations fully coordinated and progressed where warranted	Between ⅓ and ½ mile and between ⅓ and ½ mile locations fully coordinated and progressed where warranted	¼ mile and ½ mile locations fully coordinated and progressed where warranted	¼ mile minimum, preferably ½ mile
Typical Traffic Control	Signalized, four-way stop	Signalized, four-way stop	Signalized, four-way stop	Signalized, four-way stop
Access Driveway	100 feet from intersection	100 feet from intersection	100 feet from intersection	85 feet from intersection
Full Access Driveway from Signal	660 feet	880 feet	880 feet	230 feet
Partial Access Driveway from Signal	330 feet	660 feet	660 feet	115 feet
Driveway spacing	165 feet to 330 feet	60 feet (min)	No Data	65 feet to 330 feet dependent on land use
Grade Separated Interchange Spacing	One mile location where warranted	One mile location where warranted	No Data	No Data
Grade Separated Interchange Type	May include SPUJ or tight diamond if warranted and feasible	May include SPUJ or tight diamond if warranted and feasible	No Data	No Data
Frontage Road	Possible	Possible	No Data	No Data
On-Street Parking	Prohibited	Prohibited	No Data	No Data

As an arterial street, Meridian Road must accommodate traffic operations and a moderate level of property access while promoting safety of travel. To accomplish these goals recommendations on intersection, driveway and median placement are set out below.

### **Intersection Spacing**

Meridian Road is part of an arterial street grid system. Therefore, it is encouraged to restrict signalized intersections to the half-mile and mile locations only. It is recommended that each intersection be constructed to its ultimate configuration including dedicated left and right turn lanes where practical. Non-signalized intersections should be placed a minimum of 660 feet apart. Opportunities to consolidate non-signalized intersections with less than 660 feet of separation should be considered.

### **Driveway Locations**

It is recommended that access be limited for new residential driveways along the Meridian Road Corridor. Future residential developments shall be encouraged to tie directly into east-west collector or minor arterial roadways that connect to Meridian Road.

### **Median Locations**

Raised medians provide access control and improve safety and operations by minimizing midblock left turns. Median openings may allow for full or partial turning movement access. Full access allows for left turns into and out of an adjacent site. Partial access allows for left turns from the street to an adjacent site only. Care should be taken to limit the number of median openings so as not to defeat the purpose of the raised median. In general, full access median openings may be provided at sixth-mile increments (880 feet). Additional median openings should be the partial access type. Median openings are not recommended less than 660 feet from an arterial-to-arterial intersection.

### **Additional Recommendations**

Adequate sight distance shall be provided at all driveways and intersections. Right-of-way preservation should begin as early as possible. The agencies should develop and implement right-of-way preservation plans to protect future right-of-way needs and facilitate future access management policies. The majority of the land adjacent to the southern half of the Meridian Road Corridor is currently undeveloped. The agencies may want to require developers to dedicate a controlled vehicular access easement in addition to the ultimate right-of-way to help enforce access control guidelines.

### **Evaluation of Non-Motorized Modes of Transportation**

Alternative modes of transportation, such as sidewalks, bike paths/routes, and trails (including equestrian), are an important aspect of the multimodal transportation network as they provide mobility for those not able to operate or without access to a vehicle and also for recreational purpose. Very limited sidewalks and bike paths exist within the study corridor. Therefore, the provision of a safe, inviting pedestrian/bicycle environment is a crucial part of multi-modal street design. A well-designed pedestrian/bicycle environment provides the following:

- Continuous, interconnected pedestrian/bike travel corridors;

- Convenient pedestrian/bike access between commercial and residential land uses;
- Convenient access to transit facilities;
- A physical buffer between adjacent land uses and noise from street traffic; and
- Visually interesting and inviting public spaces for exercise and social interaction.

Providing access to activity centers such as schools, shopping centers, and post offices is a vital part of multi-modal street design. Within the study area there is very limited bike paths and bike lanes in both the more urban and rural areas. Portions of the study area to the east and the north consist of State and federal lands which are home to several equestrian, hiking, and multi-use trails. Access to these trails is essential to improve recreational use of these existing facilities. Both the City of Mesa and the City of Apache Junction have already prepared preliminary plans to expand the pedestrian, bicycle, and trails (including equestrian) facilities throughout the study area.

Pedestrian-oriented design embodies the notion that transportation and land use planning must be linked to provide a safe and convenient walking environment. This can be characterized by the creation of attractive, interesting places for people to gather, accessible sidewalks and walking paths, as well as protection from auto traffic.

The pedestrian plan provides an environment where walking is enjoyable and convenient for people of all ages. All trips have a pedestrian component. People must walk from their car to their destination or from their home to the bus stop and from the bus stop to their destination.

Recommendations for future pedestrian improvements focus on improving the accessibility and convenience of the overall pedestrian environment. To accomplish this it is important to include pedestrian sidewalks either adjacent or detached from the new roadway improvements. Furthermore, these facilities should connect to existing facilities to provide the continuous network.

As with pedestrian facilities, to ensure that bicycling is a viable choice of travel, it is important to provide a bicycle system that offers a continuous, integrated network of routes, lanes, and shared-use paths. Providing well-delineated space for cyclists approaching intersections helps improve continuity of the overall bicycle network.

Currently Apache Junction's Comprehensive Transportation Study recommends a potential regional trail connection from Meridain Road into the trail system within Utery Mountain Rcreation Area along with a regional bike lane and multi-use path along Baseline Road but nothing connecting to Meridian Road. Mesa do propose bike lanes for the full length of Meriadina Road between Baseline Road and Germann road.

### **Evaluation of Transit Needs**

Transit will play an increasingly important role in the regional transportation system. The need for a reliable transportation alternative is an important element in order to seamlessly connect all cities and towns within the County to both Pinal and Maricopa transit lines. There is a tremendous need to provide a variety of transportation options, given population growth

projections for the region. Improved transit service through expanded coverage and increased frequency, combined with the implementation of transit priority measures, will attract new riders and provide transportation alternatives.

Many existing transit riders are transit dependent. Improved transit service through expanded coverage and increased frequency, combined with the implementation of transit priority measures, will attract new discretionary riders. *Maricopa Association of Governments Regional Transportation Plan 2010 Update* does not include any long range transit routes for Meridian Road in any of its systems. So there is no regional funding dedicated to public transportation in the Meridian Road Corridor. Valley Metro gets funding from the transportation excise tax through MAG for public transportation in addition to whatever local or federal funding they also receive. However, it is unlikely that Valley Metro plans public transportation in the Meridian Road Corridor.

The City of Mesa has developed long range plans that make recommendations to provide a full range of transit technologies including local bus, express bus/bus rapid transit (BRT), circulators, transit priority corridors, light rail transit, and commuter rail. At present none of these include Meridian Road.

The City of Apache Junction Comprehensive Transportation Study makes recommendations for the inclusion of a new and improved route along Meridian Road. At present these do not extend south of Southern Avenue. A "Link" bus rapid transit connection from the Transit Hub to the end of the Metro light rail line in Mesa is also recommended within the study along with a diesel-powered "Sprinter" light rail vehicle connecting with the electrified Metro system. Furthermore, the report states that these services could also be supplemented by "Rapid" commuter bus service operating over US 60 into the downtown Phoenix area.

To summarize, the focus of the transit improvements should be to improve riders experience and manage system growth to attract new ridership and promote multimodal travel. It is recommended that transit improvements include new and better services along Meridain Road through increased frequency, enhanced accessibility, and coordinated multimodal mobility. There are also opportunities to include bus shelters and bus pull-outs in the new roadway improvements along with a plan for the provision of Park and Ride lots at US 60 and/or SR 24.

# **APPENDIX A**

## **EXCERPTS FROM 2009 QUALITY/LEVEL OF SERVICE HANDBOOK**

**Baker**

**Michael Baker Jr., Inc.**  
*Phoenix, Arizona*



2009

# QUALITY/LEVEL OF SERVICE



HANDBOOK

2009  
State of Florida  
Department of Transportation

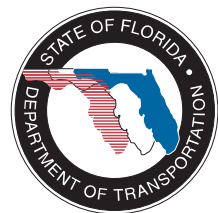

**TABLE 1**

**Generalized Annual Average Daily Volumes for Florida's Urbanized Areas<sup>1</sup>**

10/4/10

<b>STATE SIGNALIZED ARTERIALS</b>						<b>FREEWAYS</b>						
<b>Class I</b> (>0.00 to 1.99 signalized intersections per mile)						Lanes	B	C	D	E		
Lanes	Median	B	C	D	E	4	43,500	59,800	73,600	79,400		
2	Undivided	9,600	15,400	16,500	***	6	65,300	90,500	110,300	122,700		
4	Divided	29,300	35,500	36,700	***	8	87,000	120,100	146,500	166,000		
6	Divided	45,000	53,700	55,300	***	10	108,700	151,700	184,000	209,200		
8	Divided	60,800	71,800	73,800	***	12	149,300	202,100	238,600	252,500		
<b>Class II</b> (2.00 to 4.50 signalized intersections per mile)						<b>Freeway Adjustments</b>						
Lanes	Median	B	C	D	E	Auxiliary Lanes	Ramp Metering					
2	Undivided	**	10,500	15,200	16,200	+ 20,000	+ 5%					
4	Divided	**	25,000	33,200	35,100							
6	Divided	**	39,000	50,300	53,100							
8	Divided	**	53,100	67,300	70,900							
<b>Class III/IV</b> (more than 4.5 signalized intersections per mile)						<b>UNINTERRUPTED FLOW HIGHWAYS</b>						
Lanes	Median	B	C	D	E	Lanes	Median	B	C	D	E	
2	Undivided	**	5,100	11,900	14,900	2	Undivided	7,800	15,600	22,200	27,900	
4	Divided	**	12,600	28,200	31,900	4	Divided	34,300	49,600	64,300	72,800	
6	Divided	**	19,700	43,700	48,200	6	Divided	51,500	74,400	96,400	109,400	
8	Divided	**	27,000	59,500	64,700	<b>Uninterrupted Flow Highway Adjustments</b>						
						Lanes	Median	Exclusive left lanes	Adjustment factors			
						2	Divided	Yes	+5%			
						Multi	Undivided	Yes	-5%			
						Multi	Undivided	No	-25%			
<b>Non-State Signalized Roadway Adjustments</b> (Alter corresponding state volumes by the indicated percent.)						<b>BICYCLE MODE<sup>2</sup></b> (Multiply motorized vehicle volumes shown below by number of directional roadway lanes to determine two-way maximum service volumes.)						
Major City/County Roadways - 10%						Paved Shoulder/ Bicycle Lane						
Other Signalized Roadways - 35%						Coverage	B	C	D	E		
						0-49%	**	3,200	12,100	>12,100		
						50-84%	2,400	3,700	>3,700	***		
						85-100%	6,300	>6,300	***	***		
<b>State &amp; Non-State Signalized Roadway Adjustments</b> (Alter corresponding state volumes by the indicated percent.)						<b>PEDESTRIAN MODE<sup>2</sup></b> (Multiply motorized vehicle volumes shown below by number of directional roadway lanes to determine two-way maximum service volumes.)						
<b>Divided/Undivided &amp; Turn Lane Adjustments</b>						Sidewalk Coverage	B	C	D	E		
Lanes	Median	Exclusive Left Lanes	Exclusive Right Lanes	Adjustment Factors			0-49%	**	**	5,000	14,400	
2	Divided	Yes	No	+5%			50-84%	**	**	11,300	18,800	
2	Undivided	No	No	-20%			85-100%	**	11,400	18,800	>18,800	
Multi	Undivided	Yes	No	-5%								
Multi	Undivided	No	No	-25%								
-	-	-	Yes	+ 5%								
<b>One-Way Facility Adjustment</b>						<b>BUS MODE (Scheduled Fixed Route)<sup>3</sup></b> (Buses in peak hour in peak direction)						
Multiply the corresponding two-directional volumes in this table by 0.6.						Sidewalk Coverage	B	C	D	E		
						0-84%	>5	≥4	≥3	≥2		
						85-100%	>4	≥3	≥2	≥1		

<sup>1</sup> Values shown are presented as two-way annual average daily volumes for levels of service and are for the automobile/truck modes unless specifically stated. Although presented as daily volumes, they actually represent peak hour direction conditions with applicable K and D factors applied. This table does not constitute a standard and should be used only for general planning applications. The computer models from which this table is derived should be used for more specific planning applications. The table and deriving computer models should not be used for corridor or intersection design, where more refined techniques exist. Calculations are based on planning applications of the Highway Capacity Manual, Bicycle LOS Model, Pedestrian LOS Model and Transit Capacity and Quality of Service Manual, respectively for the automobile/truck, bicycle, pedestrian and bus modes.

<sup>2</sup> Level of service for the bicycle and pedestrian modes in this table is based on number of motorized vehicles, not number of bicyclists or pedestrians using the facility.

<sup>3</sup> Buses per hour shown are only for the peak hour in the single direction of the higher traffic flow.

\*\* Cannot be achieved using table input value defaults.

\*\*\* Not applicable for that level of service letter grade. For the automobile mode, volumes greater than level of service D become F because intersection capacities have been reached. For the bicycle mode, the level of service letter grade (including F) is not achievable because there is no maximum vehicle volume threshold using table input value defaults.

Source:

Florida Department of Transportation  
Systems Planning Office  
605 Suwannee Street, MS 19  
Tallahassee, FL 32399-0450

TABLE 1  
(continued)

Generalized **Annual Average Daily** Volumes for Florida's  
**Urbanized Areas**

9/4/09

INPUT VALUE ASSUMPTIONS	Uninterrupted Flow Facilities		Interrupted Flow Facilities									
	Freeways	Highways	State Arterials						Class II			
			Class I	Class II	Class III	Bicycle	Pedestrian	Bus				
<b>ROADWAY CHARACTERISTICS</b>												
Area type (l,o)	1	1	1	1	1	1	1	1	1	1	1	1
Number of through lanes	4-12	2	4-6	2	4-8	2	4-8	2	4-8	4	4	
Posted speed (mph)	65	50	50	45	50	45	45	35	35	45	45	
Free flow speed (mph)	70	55	55	50	55	50	50	40	40	50	50	
Aux, meter, or accel/decel $\geq 1500$ (n,y)	n											
Median (n, nr, r)		n	r	n	r	n	r	n	r	r	r	
Terrain (l,r)	1	1	1									
% no passing zone		80										
Exclusive left turn lanes / [impact](n, y)		[n]	y	y	y	y	y	y	y	y	y	
Exclusive right turn lanes (n, y)				n	n	n	n	n	n	n	n	
Paved shoulder/bicycle lane (n, y)										n, 50%,y	n	
Outside lane width										t	t	
Pavement condition										t		
Sidewalk (n, y)											n, 50%,y	n,y
Sidewalk/roadway separation (a, t, w)											t	
Sidewalk protective barrier (n, y)											n	
Obstacle to bus stop (n, y)												n
Facility length (mi)	4	5	5	2	2	2	2	2	2	2	2	2
Number of segments	4											
<b>TRAFFIC CHARACTERISTICS</b>												
Planning analysis hour factor (K)	0.092	0.094	0.094	0.097	0.097	0.097	0.097	0.097	0.097	0.097	0.097	
Directional distribution factor (D)	0.55	0.55	0.55	0.55	0.55	0.55	0.55	0.55	0.55	0.55	0.55	
Peak hour factor (PHF)	0.95	0.925	0.925	0.925	0.925	0.925	0.925	0.925	0.925	0.925	0.925	
Base saturation flow rate (pcphpl)		1700	2100	1950	1950	1950	1950	1950	1950	1950	1950	
Heavy vehicle percent	4.0	2.0	2.0	2.0	2.0	2.0	2.0	1.5	1.5	2.0	2.0	
Local adjustment factor	0.98	1.0	0.98									
% left turns				12	12	12	12	12	12	12	12	
% right turns				12	12	12	12	12	12	12	12	
Bus span of service												15
<b>CONTROL CHARACTERISTICS</b>												
Number of signals				2	2	6	6	10	10	6	6	
Arrival type (1-6)				3	3	4	4	4	4	4	4	
Signal type (a, s, p)				a	a	s	s	s	s	s	s	
Cycle length (C)				120	120	120	120	120	120	120	120	
Effective green ratio (g/C)				0.44	0.44	0.44	0.44	0.44	0.44	0.44	0.44	
<b>LEVEL OF SERVICE THRESHOLDS</b>												
Level of Service	Freeways	Highway Segments		State & Non-State Signalized Arterials			Bicycle	Pedestrian	Bus			
	Density	Two-Lane	Multilane	Class I	Class II	Class III	Score	Score	Buses per hr.			
B	$\leq 17$	$\geq 0.833$	$\leq 18$	$> 34$ mph	$> 28$ mph	$> 24$ mph	$\leq 2.5$	$\leq 2.5$	$\geq 4$			
C	$\leq 24$	$> 0.750$	$\leq 26$	$> 27$ mph	$> 22$ mph	$> 18$ mph	$\leq 3.5$	$\leq 3.5$	$\geq 3$			
D	$\leq 31$	$> 0.667$	$\leq 35$	$> 21$ mph	$> 17$ mph	$> 14$ mph	$\leq 4.5$	$\leq 4.5$	$\geq 2$			
E	$\leq 39$	$> 0.583$	$\leq 41$	$> 16$ mph	$> 13$ mph	$> 10$ mph	$\leq 5.5$	$\leq 5.5$	$\geq 1$			

% ffs = Percent free flow speed    ats = Average travel speed

# APPENDIX B

























2025 LOS REPORTS  
2035 LOS REPORTS

**Baker**

**Michael Baker Jr., Inc.**  
*Phoenix, Arizona*

HCM Signalized Intersection Capacity Analysis  
 11: University Drive & Meridain Road

2025 AM  
 2/4/2013

												
Movement	EBL	EBT	EBR	WBL	WBT	WBR	NBL	NBT	NBR	SBL	SBT	SBR
Lane Configurations		 			 			 			 	
Volume (vph)	13	736	275	109	188	65	85	89	111	134	146	0
Ideal Flow (vphpl)	1900	1900	1900	1900	1900	1900	1900	1900	1900	1900	1900	1900
Total Lost time (s)	4.0	4.0		4.0	4.0		4.0	4.0		4.0	4.0	
Lane Util. Factor	1.00	0.95		1.00	0.95		1.00	0.95		1.00	0.95	
Flt	1.00	0.96		1.00	0.96		1.00	0.92		1.00	1.00	
Flt Protected	0.95	1.00		0.95	1.00		0.95	1.00		0.95	1.00	
Satd. Flow (prot)	1770	3395		1770	3403		1770	3245		1770	3539	
Flt Permitted	0.58	1.00		0.20	1.00		0.65	1.00		0.61	1.00	
Satd. Flow (perm)	1079	3395		370	3403		1210	3245		1142	3539	
Peak-hour factor, PHF	0.90	0.90	0.90	0.90	0.90	0.90	0.90	0.90	0.90	0.90	0.90	0.90
Adj. Flow (vph)	14	818	306	121	209	72	94	99	123	149	162	0
RTOR Reduction (vph)	0	64	0	0	29	0	0	90	0	0	0	0
Lane Group Flow (vph)	14	1060	0	121	252	0	94	132	0	149	162	0
Turn Type	Perm			Perm			Perm			Perm		Perm
Protected Phases		4			8			2			6	
Permitted Phases	4			8			2			6		6
Actuated Green, G (s)	36.0	36.0		36.0	36.0		16.0	16.0		16.0	16.0	
Effective Green, g (s)	36.0	36.0		36.0	36.0		16.0	16.0		16.0	16.0	
Actuated g/C Ratio	0.60	0.60		0.60	0.60		0.27	0.27		0.27	0.27	
Clearance Time (s)	4.0	4.0		4.0	4.0		4.0	4.0		4.0	4.0	
Lane Grp Cap (vph)	647	2037		222	2042		323	865		305	944	
v/s Ratio Prot		0.31			0.07			0.04			0.05	
v/s Ratio Perm	0.01			c0.33			0.08			c0.13		
v/c Ratio	0.02	0.52		0.55	0.12		0.29	0.15		0.49	0.17	
Uniform Delay, d1	4.9	7.0		7.1	5.2		17.5	16.8		18.5	16.9	
Progression Factor	1.00	1.00		1.00	1.00		0.89	0.77		1.00	1.00	
Incremental Delay, d2	0.1	1.0		9.3	0.1		2.1	0.4		5.5	0.4	
Delay (s)	4.9	7.9		16.4	5.3		17.7	13.4		24.1	17.3	
Level of Service	A	A		B	A		B	B		C	B	
Approach Delay (s)		7.9			8.7			14.7			20.5	
Approach LOS		A			A			B			C	

Intersection Summary		
HCM Average Control Delay	10.8	HCM Level of Service B
HCM Volume to Capacity ratio	0.53	
Actuated Cycle Length (s)	60.0	Sum of lost time (s) 8.0
Intersection Capacity Utilization	62.0%	ICU Level of Service B
Analysis Period (min)	15	

c Critical Lane Group



HCM Signalized Intersection Capacity Analysis  
 17: Apache Trail & Meridain Road

2025 AM  
 2/4/2013

Movement	EBL	EBT	EBR	WBL	WBT	WBR	NBL	NBT	NBR	SBL	SBT	SBR
Lane Configurations												
Volume (vph)	24	999	130	186	887	140	144	266	177	276	481	48
Ideal Flow (vphpl)	1900	1900	1900	1900	1900	1900	1900	1900	1900	1900	1900	1900
Total Lost time (s)	4.0	4.0		4.0	4.0	4.0	4.0	4.0		4.0	4.0	
Lane Util. Factor	1.00	0.91		1.00	0.91	1.00	1.00	0.95		1.00	0.95	
Flt	1.00	0.98		1.00	1.00	0.85	1.00	0.94		1.00	0.99	
Flt Protected	0.95	1.00		0.95	1.00	1.00	0.95	1.00		0.95	1.00	
Satd. Flow (prot)	1770	4998		1770	5085	1583	1770	3327		1770	3491	
Flt Permitted	0.25	1.00		0.24	1.00	1.00	0.29	1.00		0.37	1.00	
Satd. Flow (perm)	466	4998		438	5085	1583	546	3327		692	3491	
Peak-hour factor, PHF	0.90	0.90	0.90	0.90	0.90	0.90	0.90	0.90	0.90	0.90	0.90	0.90
Adj. Flow (vph)	27	1110	144	207	986	156	160	296	197	307	534	53
RTOR Reduction (vph)	0	27	0	0	0	112	0	144	0	0	12	0
Lane Group Flow (vph)	27	1227	0	207	986	44	160	349	0	307	575	0
Turn Type	pm+pt			pm+pt			Perm	pm+pt		pm+pt		
Protected Phases	7	4		3	8			5	2		1	6
Permitted Phases	4			8		8	2			6		
Actuated Green, G (s)	20.0	16.0		22.0	17.0	17.0	23.0	16.0		23.0	16.0	
Effective Green, g (s)	20.0	16.0		22.0	17.0	17.0	23.0	16.0		23.0	16.0	
Actuated g/C Ratio	0.33	0.27		0.37	0.28	0.28	0.38	0.27		0.38	0.27	
Clearance Time (s)	4.0	4.0		4.0	4.0	4.0	4.0	4.0		4.0	4.0	
Lane Grp Cap (vph)	242	1333		272	1441	449	352	887		391	931	
v/s Ratio Prot	0.01	c0.25		c0.06	0.19		0.05	0.10		c0.09	0.16	
v/s Ratio Perm	0.03			0.22		0.03	0.12			c0.21		
v/c Ratio	0.11	0.92		0.76	0.68	0.10	0.45	0.39		0.79	0.62	
Uniform Delay, d1	13.8	21.4		15.1	19.1	15.9	12.8	18.0		14.3	19.3	
Progression Factor	1.00	1.00		1.00	1.00	1.00	1.00	1.00		1.04	1.01	
Incremental Delay, d2	0.9	11.8		18.0	2.7	0.4	4.2	1.3		14.3	3.0	
Delay (s)	14.8	33.1		33.1	21.8	16.3	17.0	19.3		29.1	22.5	
Level of Service	B	C		C	C	B	B	B		C	C	
Approach Delay (s)		32.7			22.9			18.8			24.8	
Approach LOS		C			C			B			C	

Intersection Summary



























HCM Average Control Delay	25.7	HCM Level of Service	C
HCM Volume to Capacity ratio	0.83		
Actuated Cycle Length (s)	60.0	Sum of lost time (s)	16.0
Intersection Capacity Utilization	74.2%	ICU Level of Service	D
Analysis Period (min)	15		

c Critical Lane Group

# HCM Signalized Intersection Capacity Analysis

## 22: Broadway Avenue & Meridain Road



























2025 AM  
2/4/2013

												
Movement	EBL	EBT	EBR	WBL	WBT	WBR	NBL	NBT	NBR	SBL	SBT	SBR
Lane Configurations		 		 	 			 			 	
Volume (vph)	24	653	199	342	314	110	99	286	367	139	382	23
Ideal Flow (vphpl)	1900	1900	1900	1900	1900	1900	1900	1900	1900	1900	1900	1900
Total Lost time (s)	4.0	4.0		4.0	4.0		4.0	4.0		4.0	4.0	
Lane Util. Factor	1.00	0.95		0.97	0.95		1.00	0.95		1.00	0.95	
Frt	1.00	0.96		1.00	0.96		1.00	0.92		1.00	0.99	
Flt Protected	0.95	1.00		0.95	1.00		0.95	1.00		0.95	1.00	
Satd. Flow (prot)	1770	3415		3433	3402		1770	3241		1770	3509	
Flt Permitted	0.48	1.00		0.95	1.00		0.46	1.00		0.27	1.00	
Satd. Flow (perm)	898	3415		3433	3402		857	3241		510	3509	
Peak-hour factor, PHF	0.90	0.90	0.90	0.90	0.90	0.90	0.90	0.90	0.90	0.90	0.90	0.90
Adj. Flow (vph)	27	726	221	380	349	122	110	318	408	154	424	26
RTOR Reduction (vph)	0	52	0	0	63	0	0	158	0	0	8	0
Lane Group Flow (vph)	27	895	0	380	408	0	110	568	0	154	442	0
Turn Type	pm+pt			Prot			Perm			Perm		
Protected Phases	7	4		3	8			2				6
Permitted Phases	4						2			6		
Actuated Green, G (s)	20.0	16.0		7.0	19.0		20.0	20.0		20.0	20.0	
Effective Green, g (s)	20.0	16.0		7.0	19.0		20.0	20.0		20.0	20.0	
Actuated g/C Ratio	0.36	0.29		0.13	0.35		0.36	0.36		0.36	0.36	
Clearance Time (s)	4.0	4.0		4.0	4.0		4.0	4.0		4.0	4.0	
Lane Grp Cap (vph)	390	993		437	1175		312	1179		185	1276	
v/s Ratio Prot	0.01	c0.26		c0.11	c0.12			0.18			0.13	
v/s Ratio Perm	0.02						0.13			c0.30		
v/c Ratio	0.07	0.90		0.87	0.35		0.35	0.48		0.83	0.35	
Uniform Delay, d1	11.3	18.7		23.6	13.4		12.8	13.5		16.0	12.7	
Progression Factor	1.00	1.00		1.00	1.00		1.00	1.00		1.00	1.00	
Incremental Delay, d2	0.3	12.8		20.4	0.8		3.1	1.4		33.5	0.7	
Delay (s)	11.7	31.5		43.9	14.2		15.9	14.9		49.4	13.5	
Level of Service	B	C		D	B		B	B		D	B	
Approach Delay (s)		31.0			27.5			15.0			22.7	
Approach LOS		C			C			B			C	
<b>Intersection Summary</b>												
HCM Average Control Delay			24.4			HCM Level of Service				C		
HCM Volume to Capacity ratio			0.92									
Actuated Cycle Length (s)			55.0			Sum of lost time (s)			16.0			
Intersection Capacity Utilization			74.9%			ICU Level of Service			D			
Analysis Period (min)			15									
c Critical Lane Group												

# HCM Signalized Intersection Capacity Analysis

## 27: Southern Avenue & Meridain Road













2025 AM  
2/4/2013

												
Movement	EBL	EBT	EBR	WBL	WBT	WBR	NBL	NBT	NBR	SBL	SBT	SBR
Lane Configurations		 			 		 	 			 	
Volume (vph)	106	94	43	0	480	199	499	600	300	29	662	123
Ideal Flow (vphpl)	1900	1900	1900	1900	1900	1900	1900	1900	1900	1900	1900	1900
Total Lost time (s)	4.0	4.0			4.0		4.0	4.0	4.0	4.0	4.0	
Lane Util. Factor	1.00	0.95			0.95		0.97	0.95	1.00	1.00	0.95	
Flt	1.00	0.95			0.96		1.00	1.00	0.85	1.00	0.98	
Flt Protected	0.95	1.00			1.00		0.95	1.00	1.00	0.95	1.00	
Satd. Flow (prot)	1770	3372			3384		3433	3539	1583	1770	3456	
Flt Permitted	0.21	1.00			1.00		0.95	1.00	1.00	0.40	1.00	
Satd. Flow (perm)	382	3372			3384		3433	3539	1583	742	3456	
Peak-hour factor, PHF	0.90	0.90	0.90	0.90	0.90	0.90	0.90	0.90	0.90	0.90	0.90	0.90
Adj. Flow (vph)	118	104	48	0	533	221	554	667	333	32	736	137
RTOR Reduction (vph)	0	31	0	0	70	0	0	0	186	0	23	0
Lane Group Flow (vph)	118	121	0	0	684	0	554	667	147	32	850	0
Turn Type	pm+pt			Perm			Prot			Perm	pm+pt	
Protected Phases	7	4			8		5	2			1	6
Permitted Phases	4			8					2		6	
Actuated Green, G (s)	22.7	22.7			15.5		11.5	28.7	28.7	20.4	18.8	
Effective Green, g (s)	22.7	22.7			15.5		11.5	28.7	28.7	20.4	18.8	
Actuated g/C Ratio	0.35	0.35			0.24		0.18	0.44	0.44	0.31	0.29	
Clearance Time (s)	4.0	4.0			4.0		4.0	4.0	4.0	4.0	4.0	
Vehicle Extension (s)	3.0	3.0			3.0		3.0	3.0	3.0	3.0	3.0	
Lane Grp Cap (vph)	202	1178			807		607	1563	699	258	1000	
v/s Ratio Prot	c0.03	0.04			c0.20		c0.16	0.19		0.00	c0.25	
v/s Ratio Perm	0.18								0.09	0.04		
v/c Ratio	0.58	0.10			0.85		0.91	0.43	0.21	0.12	0.85	
Uniform Delay, d1	16.4	14.3			23.6		26.3	12.5	11.2	15.6	21.8	
Progression Factor	1.00	1.00			1.00		1.00	1.00	1.00	1.00	1.00	
Incremental Delay, d2	4.3	0.0			8.2		18.1	0.9	0.7	0.2	9.0	
Delay (s)	20.7	14.3			31.9		44.4	13.3	11.9	15.8	30.7	
Level of Service	C	B			C		D	B	B	B	C	
Approach Delay (s)		17.1			31.9			24.1			30.2	
Approach LOS		B			C			C			C	
<b>Intersection Summary</b>												
HCM Average Control Delay			26.8			HCM Level of Service			C			
HCM Volume to Capacity ratio			0.85									
Actuated Cycle Length (s)			65.0			Sum of lost time (s)		16.0				
Intersection Capacity Utilization			75.3%			ICU Level of Service			D			
Analysis Period (min)			15									
c Critical Lane Group												

# HCM Signalized Intersection Capacity Analysis

## 68: US 60 WB On-Ramp & Meridain Road











2025 AM  
2/4/2013

						
Movement	EBL	EBR	NBL	NBT	SBT	SBR
Lane Configurations			 	 	 	
Volume (vph)	0	0	836	465	530	456
Ideal Flow (vphpl)	1900	1900	1900	1900	1900	1900
Total Lost time (s)			4.0	4.0	4.0	4.0
Lane Util. Factor			0.97	0.95	0.95	1.00
Flt			1.00	1.00	1.00	0.85
Flt Protected			0.95	1.00	1.00	1.00
Satd. Flow (prot)			3433	3539	3539	1583
Flt Permitted			0.12	1.00	1.00	1.00
Satd. Flow (perm)			421	3539	3539	1583
Peak-hour factor, PHF	0.90	0.90	0.90	0.90	0.90	0.90
Adj. Flow (vph)	0	0	929	517	589	507
RTOR Reduction (vph)	0	0	0	0	0	274
Lane Group Flow (vph)	0	0	929	517	589	233
Turn Type			pm+pt			Perm
Protected Phases			2	5 6	6	
Permitted Phases			5 6			6
Actuated Green, G (s)			56.0	60.0	16.0	16.0
Effective Green, g (s)			56.0	60.0	16.0	16.0
Actuated g/C Ratio			0.93	1.00	0.27	0.27
Clearance Time (s)			4.0		4.0	4.0
Lane Grp Cap (vph)			1196	3539	944	422
v/s Ratio Prot			c0.21	0.15	0.17	
v/s Ratio Perm			c0.52			0.15
v/c Ratio			0.78	0.15	0.62	0.55
Uniform Delay, d1			15.4	0.0	19.4	18.9
Progression Factor			0.58	1.00	1.00	1.00
Incremental Delay, d2			2.3	0.0	3.1	5.1
Delay (s)			11.1	0.0	22.5	24.0
Level of Service			B	A	C	C
Approach Delay (s)	0.0			7.2	23.2	
Approach LOS	A			A	C	
<b>Intersection Summary</b>						
HCM Average Control Delay			14.1	HCM Level of Service		B
HCM Volume to Capacity ratio			0.76			
Actuated Cycle Length (s)			60.0	Sum of lost time (s)		4.0
Intersection Capacity Utilization			58.8%	ICU Level of Service		B
Analysis Period (min)			15			
c Critical Lane Group						

# HCM Signalized Intersection Capacity Analysis

## 71: US 60 EB Off-Ramp & Meridain Road

2025 AM  
2/4/2013



























						
Movement	EBL	EBR	NBL	NBT	SBT	SBR
Lane Configurations						
Volume (vph)	124	414	0	1177	530	0
Ideal Flow (vphpl)	1900	1900	1900	1900	1900	1900
Grade (%)	1%			0%	0%	
Total Lost time (s)	4.0	4.0		4.0	4.0	
Lane Util. Factor	1.00	0.88		0.91	0.95	
Frt	1.00	0.85		1.00	1.00	
Flt Protected	0.95	1.00		1.00	1.00	
Satd. Flow (prot)	1761	2773		5085	3539	
Flt Permitted	0.95	1.00		1.00	1.00	
Satd. Flow (perm)	1761	2773		5085	3539	
Peak-hour factor, PHF	0.90	0.90	0.90	0.90	0.90	0.90
Adj. Flow (vph)	138	460	0	1308	589	0
RTOR Reduction (vph)	0	40	0	0	0	0
Lane Group Flow (vph)	138	420	0	1308	589	0
Turn Type	Perm					
Protected Phases	4 12			2	2	
Permitted Phases		4 12				
Actuated Green, G (s)	36.0	36.0		16.0	16.0	
Effective Green, g (s)	36.0	36.0		16.0	16.0	
Actuated g/C Ratio	0.60	0.60		0.27	0.27	
Clearance Time (s)				4.0	4.0	
Lane Grp Cap (vph)	1057	1664		1356	944	
v/s Ratio Prot	0.08			0.26	0.17	
v/s Ratio Perm		0.15				
v/c Ratio	0.13	0.25		0.96	0.62	
Uniform Delay, d1	5.2	5.7		21.7	19.4	
Progression Factor	1.00	1.00		1.00	0.76	
Incremental Delay, d2	0.3	0.4		17.3	2.4	
Delay (s)	5.5	6.0		39.0	17.2	
Level of Service	A	A		D	B	
Approach Delay (s)	5.9			39.0	17.2	
Approach LOS	A			D	B	
<b>Intersection Summary</b>						
HCM Average Control Delay			25.9	HCM Level of Service		C
HCM Volume to Capacity ratio			0.47			
Actuated Cycle Length (s)			60.0	Sum of lost time (s)		8.0
Intersection Capacity Utilization			58.8%	ICU Level of Service		B
Analysis Period (min)			15			
c Critical Lane Group						



# HCM Signalized Intersection Capacity Analysis

## 31: Baseline Road & Meridain Road

























2025 AM  
2/4/2013

												
Movement	EBL	EBT	EBR	WBL	WBT	WBR	NBL	NBT	NBR	SBL	SBT	SBR
Lane Configurations		 			 	 		 			 	
Volume (vph)	102	266	20	75	602	828	44	1314	102	231	286	406
Ideal Flow (vphpl)	1900	1900	1900	1900	1900	1900	1900	1900	1900	1900	1900	1900
Total Lost time (s)	4.0	4.0		4.0	4.0	4.0	4.0	4.0		4.0	4.0	4.0
Lane Util. Factor	1.00	0.95		1.00	0.95	0.88	1.00	0.91		1.00	0.95	1.00
Flt	1.00	0.99		1.00	1.00	0.85	1.00	0.99		1.00	1.00	0.85
Flt Protected	0.95	1.00		0.95	1.00	1.00	0.95	1.00		0.95	1.00	1.00
Satd. Flow (prot)	1770	3502		1770	3539	2787	1770	5030		1770	3539	1583
Flt Permitted	0.26	1.00		0.52	1.00	1.00	0.56	1.00		0.15	1.00	1.00
Satd. Flow (perm)	484	3502		968	3539	2787	1041	5030		277	3539	1583
Peak-hour factor, PHF	0.90	0.90	0.90	0.90	0.90	0.90	0.90	0.90	0.90	0.90	0.90	0.90
Adj. Flow (vph)	113	296	22	83	669	920	49	1460	113	257	318	451
RTOR Reduction (vph)	0	8	0	0	0	64	0	13	0	0	0	113
Lane Group Flow (vph)	113	310	0	83	669	856	49	1560	0	257	318	338
Turn Type	pm+pt			pm+pt		pm+ov	Perm			pm+pt		Perm
Protected Phases	7	4		3	8	1		2		1	6	
Permitted Phases	4			8		8	2			6		6
Actuated Green, G (s)	18.6	15.4		18.6	15.4	22.9	22.9	22.9		34.4	34.4	34.4
Effective Green, g (s)	18.6	15.4		18.6	15.4	22.9	22.9	22.9		34.4	34.4	34.4
Actuated g/C Ratio	0.29	0.24		0.29	0.24	0.35	0.35	0.35		0.53	0.53	0.53
Clearance Time (s)	4.0	4.0		4.0	4.0	4.0	4.0	4.0		4.0	4.0	4.0
Vehicle Extension (s)	3.0	3.0		3.0	3.0	3.0	3.0	3.0		3.0	3.0	3.0
Lane Grp Cap (vph)	202	830		316	838	1153	367	1772		319	1873	838
v/s Ratio Prot	c0.03	0.09		0.01	0.19	c0.09		0.31		0.09	0.09	
v/s Ratio Perm	0.13			0.06		0.22	0.05			c0.33		0.21
v/c Ratio	0.56	0.37		0.26	0.80	0.74	0.13	0.88		0.81	0.17	0.40
Uniform Delay, d1	18.3	20.8		17.4	23.3	18.5	14.3	19.8		12.4	7.9	9.2
Progression Factor	1.00	1.00		1.00	1.00	1.00	1.00	1.00		1.00	1.00	1.00
Incremental Delay, d2	3.3	0.3		0.4	5.3	2.6	0.8	6.7		13.7	0.2	1.4
Delay (s)	21.6	21.0		17.8	28.7	21.1	15.1	26.4		26.2	8.1	10.6
Level of Service	C	C		B	C	C	B	C		C	A	B
Approach Delay (s)		21.2			24.0			26.1			13.7	
Approach LOS		C			C			C			B	
<b>Intersection Summary</b>												
HCM Average Control Delay			22.2				HCM Level of Service			C		
HCM Volume to Capacity ratio			0.74									
Actuated Cycle Length (s)			65.0				Sum of lost time (s)			8.0		
Intersection Capacity Utilization			76.1%				ICU Level of Service			D		
Analysis Period (min)			15									
c Critical Lane Group												

# HCM Signalized Intersection Capacity Analysis

## 2: Guadalupe Road & Meridian Road

























2025 AM  
2/4/2013

												
Movement	EBL	EBT	EBR	WBL	WBT	WBR	NBL	NBT	NBR	SBL	SBT	SBR
Lane Configurations		 			 			 			 	
Volume (vph)	212	239	80	36	301	119	188	931	63	33	485	146
Ideal Flow (vphpl)	1900	1900	1900	1900	1900	1900	1900	1900	1900	1900	1900	1900
Total Lost time (s)	4.0	4.0		4.0	4.0		4.0	4.0		4.0	4.0	
Lane Util. Factor	1.00	0.95		1.00	0.95		1.00	0.95		1.00	0.95	
Flt	1.00	0.96		1.00	0.96		1.00	0.99		1.00	0.97	
Flt Protected	0.95	1.00		0.95	1.00		0.95	1.00		0.95	1.00	
Satd. Flow (prot)	1770	3406		1770	3389		1770	3506		1770	3417	
Flt Permitted	0.37	1.00		0.54	1.00		0.32	1.00		0.15	1.00	
Satd. Flow (perm)	693	3406		1005	3389		598	3506		276	3417	
Peak-hour factor, PHF	0.90	0.90	0.90	0.90	0.90	0.90	0.90	0.90	0.90	0.90	0.90	0.90
Adj. Flow (vph)	236	266	89	40	334	132	209	1034	70	37	539	162
RTOR Reduction (vph)	0	54	0	0	53	0	0	8	0	0	47	0
Lane Group Flow (vph)	236	301	0	40	413	0	209	1096	0	37	654	0
Turn Type	pm+pt			pm+pt			Perm			Perm		
Protected Phases	7	4		3	8			2				6
Permitted Phases	4			8			2			6		
Actuated Green, G (s)	22.0	17.0		20.0	16.0		27.0	27.0		27.0	27.0	
Effective Green, g (s)	22.0	17.0		20.0	16.0		27.0	27.0		27.0	27.0	
Actuated g/C Ratio	0.37	0.28		0.33	0.27		0.45	0.45		0.45	0.45	
Clearance Time (s)	4.0	4.0		4.0	4.0		4.0	4.0		4.0	4.0	
Lane Grp Cap (vph)	344	965		386	904		269	1578		124	1538	
v/s Ratio Prot	c0.06	0.09		0.01	0.12			0.31			0.19	
v/s Ratio Perm	c0.19			0.03			c0.35			0.13		
v/c Ratio	0.69	0.31		0.10	0.46		0.78	0.69		0.30	0.43	
Uniform Delay, d1	14.6	16.9		13.6	18.4		14.0	13.2		10.5	11.2	
Progression Factor	1.00	1.00		1.00	1.00		1.00	1.00		1.00	1.00	
Incremental Delay, d2	10.6	0.8		0.5	1.7		19.5	2.5		6.1	0.9	
Delay (s)	25.2	17.7		14.2	20.0		33.5	15.7		16.5	12.1	
Level of Service	C	B		B	C		C	B		B	B	
Approach Delay (s)		20.7			19.6			18.6			12.3	
Approach LOS		C			B			B			B	
<b>Intersection Summary</b>												
HCM Average Control Delay			17.7			HCM Level of Service			B			
HCM Volume to Capacity ratio			0.69									
Actuated Cycle Length (s)			60.0			Sum of lost time (s)			8.0			
Intersection Capacity Utilization			68.3%			ICU Level of Service			C			
Analysis Period (min)			15									
c Critical Lane Group												

# HCM Signalized Intersection Capacity Analysis

## 35: Elliot Road & Meridian Road

2025 AM  
2/4/2013

												
Movement	EBL	EBT	EBR	WBL	WBT	WBR	NBL	NBT	NBR	SBL	SBT	SBR
Lane Configurations		 			 			 			 	
Volume (vph)	56	955	112	205	1026	137	292	612	68	101	489	130
Ideal Flow (vphpl)	1900	1900	1900	1900	1900	1900	1900	1900	1900	1900	1900	1900
Total Lost time (s)	4.0	4.0		4.0	4.0		4.0	4.0		4.0	4.0	
Lane Util. Factor	1.00	0.91		1.00	0.91		0.97	0.95		1.00	0.95	
Flt	1.00	0.98		1.00	0.98		1.00	0.98		1.00	0.97	
Flt Protected	0.95	1.00		0.95	1.00		0.95	1.00		0.95	1.00	
Satd. Flow (prot)	1770	5005		1770	4996		3433	3486		1770	3428	
Flt Permitted	0.23	1.00		0.20	1.00		0.95	1.00		0.26	1.00	
Satd. Flow (perm)	423	5005		369	4996		3433	3486		486	3428	
Peak-hour factor, PHF	0.90	0.90	0.90	0.90	0.90	0.90	0.90	0.90	0.90	0.90	0.90	0.90
Adj. Flow (vph)	62	1061	124	228	1140	152	324	680	76	112	543	144
RTOR Reduction (vph)	0	24	0	0	27	0	0	14	0	0	39	0
Lane Group Flow (vph)	62	1161	0	228	1265	0	324	742	0	112	648	0
Turn Type	pm+pt			pm+pt			Prot			pm+pt		
Protected Phases	7	4		3	8		5	2		1	6	
Permitted Phases	4			8						6		
Actuated Green, G (s)	20.0	17.6		25.2	20.2		6.0	20.6		21.0	17.8	
Effective Green, g (s)	20.0	17.6		25.2	20.2		6.0	20.6		21.0	17.8	
Actuated g/C Ratio	0.32	0.28		0.40	0.32		0.10	0.33		0.34	0.29	
Clearance Time (s)	4.0	4.0		4.0	4.0		4.0	4.0		4.0	4.0	
Vehicle Extension (s)	3.0	3.0		3.0	3.0		3.0	3.0		3.0	3.0	
Lane Grp Cap (vph)	187	1412		261	1617		330	1151		229	978	
v/s Ratio Prot	0.01	0.23		c0.07	0.25		c0.09	c0.21		0.03	0.19	
v/s Ratio Perm	0.09			c0.28						0.14		
v/c Ratio	0.33	0.82		0.87	0.78		0.98	0.64		0.49	0.66	
Uniform Delay, d1	15.5	20.9		15.3	19.1		28.1	17.8		14.9	19.7	
Progression Factor	1.00	1.00		1.00	1.00		1.00	1.00		1.00	1.00	
Incremental Delay, d2	1.0	4.0		25.9	2.5		44.4	2.8		1.6	3.5	
Delay (s)	16.6	24.9		41.3	21.7		72.5	20.6		16.6	23.2	
Level of Service	B	C		D	C		E	C		B	C	
Approach Delay (s)		24.5			24.6			36.2			22.2	
Approach LOS		C			C			D			C	
<b>Intersection Summary</b>												
HCM Average Control Delay			26.9			HCM Level of Service				C		
HCM Volume to Capacity ratio			0.86									
Actuated Cycle Length (s)			62.4			Sum of lost time (s)			16.0			
Intersection Capacity Utilization			71.6%			ICU Level of Service				C		
Analysis Period (min)			15									
c Critical Lane Group												























HCM Signalized Intersection Capacity Analysis  
37: Warner Road & Meridian Road

2025 AM  
2/4/2013

Movement	EBL	EBT	EBR	WBL	WBT	WBR	NBL	NBT	NBR	SBL	SBT	SBR
Lane Configurations												
Volume (vph)	176	926	70	212	1226	160	112	620	95	175	876	117
Ideal Flow (vphpl)	1900	1900	1900	1900	1900	1900	1900	1900	1900	1900	1900	1900
Total Lost time (s)	4.0	4.0	4.0	4.0	4.0		4.0	4.0		4.0	4.0	
Lane Util. Factor	0.97	0.91	1.00	1.00	0.91		1.00	0.95		1.00	0.95	
Frt	1.00	1.00	0.85	1.00	0.98		1.00	0.98		1.00	0.98	
Flt Protected	0.95	1.00	1.00	0.95	1.00		0.95	1.00		0.95	1.00	
Satd. Flow (prot)	3433	5085	1583	1770	4997		1770	3468		1770	3477	
Flt Permitted	0.95	1.00	1.00	0.17	1.00		0.18	1.00		0.15	1.00	
Satd. Flow (perm)	3433	5085	1583	320	4997		337	3468		285	3477	
Peak-hour factor, PHF	0.90	0.90	0.90	0.90	0.90	0.90	0.90	0.90	0.90	0.90	0.90	0.90
Adj. Flow (vph)	196	1029	78	236	1362	178	124	689	106	194	973	130
RTOR Reduction (vph)	0	0	58	0	22	0	0	16	0	0	13	0
Lane Group Flow (vph)	196	1029	20	236	1518	0	124	779	0	194	1090	0
Turn Type	Prot		Perm	pm+pt			pm+pt			pm+pt		
Protected Phases	7	4		3	8		5	2		1	6	
Permitted Phases			4	8			2			6		
Actuated Green, G (s)	5.0	19.3	19.3	33.0	24.0		25.3	22.1		34.0	26.8	
Effective Green, g (s)	5.0	19.3	19.3	33.0	24.0		25.3	22.1		34.0	26.8	
Actuated g/C Ratio	0.07	0.26	0.26	0.44	0.32		0.34	0.29		0.45	0.36	
Clearance Time (s)	4.0	4.0	4.0	4.0	4.0		4.0	4.0		4.0	4.0	
Vehicle Extension (s)	3.0	3.0	3.0	3.0	3.0		3.0	3.0		3.0	3.0	
Lane Grp Cap (vph)	229	1309	407	328	1599		175	1022		286	1242	
v/s Ratio Prot	0.06	0.20		c0.09	c0.30		0.03	0.22		c0.07	c0.31	
v/s Ratio Perm			0.01	0.22			0.21			0.24		
v/c Ratio	0.86	0.79	0.05	0.72	0.95		0.71	0.76		0.68	0.88	
Uniform Delay, d1	34.6	25.9	20.9	15.6	24.9		20.9	24.1		14.9	22.6	
Progression Factor	1.00	1.00	1.00	1.00	1.00		1.00	1.00		1.00	1.00	
Incremental Delay, d2	25.5	3.2	0.1	7.4	12.3		12.3	5.4		6.3	8.9	
Delay (s)	60.1	29.1	21.0	22.9	37.2		33.2	29.4		21.2	31.5	
Level of Service	E	C	C	C	D		C	C		C	C	
Approach Delay (s)		33.3			35.3			29.9			29.9	
Approach LOS		C			D			C			C	
<b>Intersection Summary</b>												
HCM Average Control Delay			32.6			HCM Level of Service				C		
HCM Volume to Capacity ratio			0.82									
Actuated Cycle Length (s)			75.0			Sum of lost time (s)			8.0			
Intersection Capacity Utilization			79.8%			ICU Level of Service				D		
Analysis Period (min)			15									
c Critical Lane Group												

HCM Signalized Intersection Capacity Analysis  
41: Ray Road & Meridian Road

2025 AM  
2/4/2013





















												
Movement	EBL	EBT	EBR	WBL	WBT	WBR	NBL	NBT	NBR	SBL	SBT	SBR
Lane Configurations												
Volume (vph)	148	802	106	298	1623	222	127	597	83	95	525	61
Ideal Flow (vphpl)	1900	1900	1900	1900	1900	1900	1900	1900	1900	1900	1900	1900
Total Lost time (s)	4.0	4.0		4.0	4.0	4.0	4.0	4.0		4.0	4.0	
Lane Util. Factor	0.97	0.91		0.97	0.91	1.00	1.00	0.95		1.00	0.95	
Flt	1.00	0.98		1.00	1.00	0.85	1.00	0.98		1.00	0.98	
Flt Protected	0.95	1.00		0.95	1.00	1.00	0.95	1.00		0.95	1.00	
Satd. Flow (prot)	3433	4996		3433	5085	1583	1770	3475		1770	3484	
Flt Permitted	0.95	1.00		0.95	1.00	1.00	0.30	1.00		0.24	1.00	
Satd. Flow (perm)	3433	4996		3433	5085	1583	568	3475		452	3484	
Peak-hour factor, PHF	0.90	0.90	0.90	0.90	0.90	0.90	0.90	0.90	0.90	0.90	0.90	0.90
Adj. Flow (vph)	164	891	118	331	1803	247	141	663	92	106	583	68
RTOR Reduction (vph)	0	28	0	0	0	49	0	18	0	0	15	0
Lane Group Flow (vph)	164	981	0	331	1803	198	141	737	0	106	636	0
Turn Type	Prot			Prot		Perm	Perm			Perm		
Protected Phases	7	4		3	8			2				6
Permitted Phases						8	2			6		
Actuated Green, G (s)	4.0	17.5		9.5	23.0	23.0	21.0	21.0		21.0	21.0	
Effective Green, g (s)	4.0	17.5		9.5	23.0	23.0	21.0	21.0		21.0	21.0	
Actuated g/C Ratio	0.07	0.29		0.16	0.38	0.38	0.35	0.35		0.35	0.35	
Clearance Time (s)	4.0	4.0		4.0	4.0	4.0	4.0	4.0		4.0	4.0	
Vehicle Extension (s)	3.0	3.0		3.0	3.0	3.0	3.0	3.0		3.0	3.0	
Lane Grp Cap (vph)	229	1457		544	1949	607	199	1216		158	1219	
v/s Ratio Prot	0.05	0.20		c0.10	c0.35			0.21			0.18	
v/s Ratio Perm						0.12	c0.25			0.23		
v/c Ratio	0.72	0.67		0.61	0.93	0.33	0.71	0.61		0.67	0.52	
Uniform Delay, d1	27.4	18.7		23.5	17.7	13.0	16.9	16.1		16.6	15.5	
Progression Factor	1.00	1.00		1.00	1.00	1.00	1.00	1.00		1.00	1.00	
Incremental Delay, d2	10.2	1.2		1.9	8.0	0.3	19.2	2.2		20.4	1.6	
Delay (s)	37.6	20.0		25.5	25.7	13.4	36.0	18.3		37.0	17.1	
Level of Service	D	B		C	C	B	D	B		D	B	
Approach Delay (s)		22.4			24.4			21.1			19.9	
Approach LOS		C			C			C			B	
<b>Intersection Summary</b>												
HCM Average Control Delay			22.7									HCM Level of Service C
HCM Volume to Capacity ratio			0.82									
Actuated Cycle Length (s)			60.0									Sum of lost time (s) 12.0
Intersection Capacity Utilization			73.3%									ICU Level of Service D
Analysis Period (min)			15									
c Critical Lane Group												



# HCM Signalized Intersection Capacity Analysis

## 58: Williams Field Road & Meridian Road

























2025 AM  
2/4/2013

												
Movement	EBL	EBT	EBR	WBL	WBT	WBR	NBL	NBT	NBR	SBL	SBT	SBR
Lane Configurations												
Volume (vph)	235	1162	173	235	1176	157	31	465	122	140	1067	67
Ideal Flow (vphpl)	1900	1900	1900	1900	1900	1900	1900	1900	1900	1900	1900	1900
Total Lost time (s)	4.0	4.0		4.0	4.0		4.0	4.0		4.0	4.0	
Lane Util. Factor	0.97	0.91		0.97	0.91		1.00	0.95		1.00	0.95	
Fr <sub>t</sub>	1.00	0.98		1.00	0.98		1.00	0.97		1.00	0.99	
Fl <sub>t</sub> Protected	0.95	1.00		0.95	1.00		0.95	1.00		0.95	1.00	
Satd. Flow (prot)	3433	4987		3433	4996		1770	3429		1770	3508	
Fl <sub>t</sub> Permitted	0.95	1.00		0.95	1.00		0.15	1.00		0.29	1.00	
Satd. Flow (perm)	3433	4987		3433	4996		276	3429		537	3508	
Peak-hour factor, PHF	0.90	0.90	0.90	0.90	0.90	0.90	0.90	0.90	0.90	0.90	0.90	0.90
Adj. Flow (vph)	261	1291	192	261	1307	174	34	517	136	156	1186	74
RTOR Reduction (vph)	0	27	0	0	24	0	0	32	0	0	6	0
Lane Group Flow (vph)	261	1456	0	261	1457	0	34	621	0	156	1254	0
Turn Type	Prot			Prot			pm+pt			pm+pt		
Protected Phases	7	4		3	8		5	2		1	6	
Permitted Phases							2			6		
Actuated Green, G (s)	7.0	21.0		7.0	21.0		27.8	27.0		30.2	28.2	
Effective Green, g (s)	7.0	21.0		7.0	21.0		27.8	27.0		30.2	28.2	
Actuated g/C Ratio	0.10	0.29		0.10	0.29		0.38	0.37		0.41	0.39	
Clearance Time (s)	4.0	4.0		4.0	4.0		4.0	4.0		4.0	4.0	
Vehicle Extension (s)	3.0	3.0		3.0	3.0		3.0	3.0		3.0	3.0	
Lane Grp Cap (vph)	329	1435		329	1437		121	1268		256	1355	
v/s Ratio Prot	c0.08	c0.29		0.08	0.29		0.00	0.18		c0.02	c0.36	
v/s Ratio Perm							0.10			0.24		
v/c Ratio	0.79	1.01		0.79	1.01		0.28	0.49		0.61	0.93	
Uniform Delay, d <sub>1</sub>	32.3	26.0		32.3	26.0		18.6	17.7		18.0	21.4	
Progression Factor	1.00	1.00		1.00	1.00		1.00	1.00		1.00	1.00	
Incremental Delay, d <sub>2</sub>	12.3	27.4		12.3	27.3		1.3	1.4		4.1	12.1	
Delay (s)	44.6	53.4		44.6	53.3		19.9	19.1		22.0	33.5	
Level of Service	D	D		D	D		B	B		C	C	
Approach Delay (s)		52.1			52.0			19.1			32.2	
Approach LOS		D			D			B			C	
<b>Intersection Summary</b>												
HCM Average Control Delay			43.0	HCM Level of Service				D				
HCM Volume to Capacity ratio			0.89									
Actuated Cycle Length (s)			73.0	Sum of lost time (s)				12.0				
Intersection Capacity Utilization			81.3%	ICU Level of Service				D				
Analysis Period (min)			15									
c Critical Lane Group												

# HCM Signalized Intersection Capacity Analysis

## 60: Pecos Road & Meridian Road

2025 AM  
2/4/2013

												
Movement	EBL	EBT	EBR	WBL	WBT	WBR	NBL	NBT	NBR	SBL	SBT	SBR
Lane Configurations		 			 			 			 	
Volume (vph)	43	427	140	123	957	94	57	428	86	90	260	15
Ideal Flow (vphpl)	1900	1900	1900	1900	1900	1900	1900	1900	1900	1900	1900	1900
Total Lost time (s)	4.0	4.0		4.0	4.0		4.0	4.0		4.0	4.0	
Lane Util. Factor	1.00	0.95		1.00	0.95		1.00	0.95		1.00	0.95	
Frt	1.00	0.96		1.00	0.99		1.00	0.97		1.00	0.99	
Flt Protected	0.95	1.00		0.95	1.00		0.95	1.00		0.95	1.00	
Satd. Flow (prot)	1770	3408		1770	3492		1770	3450		1770	3510	
Flt Permitted	0.15	1.00		0.36	1.00		0.57	1.00		0.26	1.00	
Satd. Flow (perm)	276	3408		671	3492		1053	3450		479	3510	
Peak-hour factor, PHF	0.90	0.90	0.90	0.90	0.90	0.90	0.90	0.90	0.90	0.90	0.90	0.90
Adj. Flow (vph)	48	474	156	137	1063	104	63	476	96	100	289	17
RTOR Reduction (vph)	0	53	0	0	12	0	0	28	0	0	7	0
Lane Group Flow (vph)	48	577	0	137	1155	0	63	544	0	100	299	0
Turn Type	Perm			Perm			Perm			pm+pt		
Protected Phases		4			8			2		1	6	
Permitted Phases	4			8			2			6		
Actuated Green, G (s)	27.0	27.0		27.0	27.0		17.0	17.0		25.0	25.0	
Effective Green, g (s)	27.0	27.0		27.0	27.0		17.0	17.0		25.0	25.0	
Actuated g/C Ratio	0.45	0.45		0.45	0.45		0.28	0.28		0.42	0.42	
Clearance Time (s)	4.0	4.0		4.0	4.0		4.0	4.0		4.0	4.0	
Lane Grp Cap (vph)	124	1534		302	1571		298	978		286	1463	
v/s Ratio Prot		0.17			c0.33			c0.16		c0.02	0.09	
v/s Ratio Perm	0.17			0.20			0.06			0.12		
v/c Ratio	0.39	0.38		0.45	0.74		0.21	0.56		0.35	0.20	
Uniform Delay, d1	11.0	10.9		11.4	13.6		16.4	18.3		11.5	11.2	
Progression Factor	1.00	1.00		1.00	1.00		0.89	0.92		1.00	1.00	
Incremental Delay, d2	8.9	0.7		4.9	3.1		1.0	1.5		3.3	0.3	
Delay (s)	19.9	11.6		16.3	16.7		15.6	18.2		14.9	11.5	
Level of Service	B	B		B	B		B	B		B	B	
Approach Delay (s)		12.2			16.6			18.0			12.3	
Approach LOS		B			B			B			B	

### Intersection Summary

























HCM Average Control Delay	15.3	HCM Level of Service	B
HCM Volume to Capacity ratio	0.64		
Actuated Cycle Length (s)	60.0	Sum of lost time (s)	12.0
Intersection Capacity Utilization	65.7%	ICU Level of Service	C
Analysis Period (min)	15		

c Critical Lane Group

# HCM Signalized Intersection Capacity Analysis

























## 50: Germann Road & Meridian Road

2025 AM  
2/4/2013

												
Movement	EBL	EBT	EBR	WBL	WBT	WBR	NBL	NBT	NBR	SBL	SBT	SBR
Lane Configurations		 			 			 			 	
Volume (vph)	193	374	56	51	630	335	67	432	62	220	310	34
Ideal Flow (vphpl)	1900	1900	1900	1900	1900	1900	1900	1900	1900	1900	1900	1900
Total Lost time (s)	4.0	4.0		4.0	4.0		4.0	4.0		4.0	4.0	
Lane Util. Factor	1.00	0.95		1.00	0.95		1.00	0.95		1.00	0.95	
Frt	1.00	0.98		1.00	0.95		1.00	0.98		1.00	0.99	
Flt Protected	0.95	1.00		0.95	1.00		0.95	1.00		0.95	1.00	
Satd. Flow (prot)	1770	3470		1770	3355		1770	3472		1770	3486	
Flt Permitted	0.21	1.00		0.43	1.00		0.53	1.00		0.26	1.00	
Satd. Flow (perm)	392	3470		810	3355		979	3472		482	3486	
Peak-hour factor, PHF	0.90	0.90	0.90	0.90	0.90	0.90	0.90	0.90	0.90	0.90	0.90	0.90
Adj. Flow (vph)	214	416	62	57	700	372	74	480	69	244	344	38
RTOR Reduction (vph)	0	20	0	0	116	0	0	19	0	0	14	0
Lane Group Flow (vph)	214	458	0	57	956	0	74	530	0	244	368	0
Turn Type	pm+pt			pm+pt			Perm			pm+pt		
Protected Phases	7	4		3	8			2		1	6	
Permitted Phases	4			8			2			6		
Actuated Green, G (s)	24.0	19.0		22.0	18.0		16.0	16.0		25.0	25.0	
Effective Green, g (s)	24.0	19.0		22.0	18.0		16.0	16.0		25.0	25.0	
Actuated g/C Ratio	0.40	0.32		0.37	0.30		0.27	0.27		0.42	0.42	
Clearance Time (s)	4.0	4.0		4.0	4.0		4.0	4.0		4.0	4.0	
Lane Grp Cap (vph)	272	1099		361	1007		261	926		308	1453	
v/s Ratio Prot	c0.07	0.13		0.01	c0.28			0.15		c0.07	0.11	
v/s Ratio Perm	0.25			0.05			0.08			c0.26		
v/c Ratio	0.79	0.42		0.16	0.95		0.28	0.57		0.79	0.25	
Uniform Delay, d1	14.4	16.1		12.5	20.6		17.5	19.0		13.4	11.4	
Progression Factor	1.00	1.00		1.00	1.00		1.00	1.00		1.08	0.97	
Incremental Delay, d2	20.2	1.2		0.9	18.5		2.7	2.6		18.1	0.4	
Delay (s)	34.6	17.3		13.4	39.0		20.2	21.6		32.6	11.5	
Level of Service	C	B		B	D		C	C		C	B	
Approach Delay (s)		22.6			37.7			21.4			19.7	
Approach LOS		C			D			C			B	
<b>Intersection Summary</b>												
HCM Average Control Delay			27.3			HCM Level of Service				C		
HCM Volume to Capacity ratio			0.83									
Actuated Cycle Length (s)			60.0			Sum of lost time (s)			12.0			
Intersection Capacity Utilization			78.3%			ICU Level of Service			D			
Analysis Period (min)			15									
c Critical Lane Group												

HCM Signalized Intersection Capacity Analysis  
 11: University Drive & Meridain Road

2025 PM  
 2/4/2013

												
Movement	EBL	EBT	EBR	WBL	WBT	WBR	NBL	NBT	NBR	SBL	SBT	SBR
Lane Configurations		 			 			 			 	
Volume (vph)	36	714	195	53	210	48	109	122	130	69	138	20
Ideal Flow (vphpl)	1900	1900	1900	1900	1900	1900	1900	1900	1900	1900	1900	1900
Total Lost time (s)	4.0	4.0		4.0	4.0		4.0	4.0		4.0	4.0	4.0
Lane Util. Factor	1.00	0.95		1.00	0.95		1.00	0.95		1.00	0.95	1.00
Flt	1.00	0.97		1.00	0.97		1.00	0.92		1.00	1.00	0.85
Flt Protected	0.95	1.00		0.95	1.00		0.95	1.00		0.95	1.00	1.00
Satd. Flow (prot)	1770	3425		1770	3441		1770	3266		1770	3539	1583
Flt Permitted	0.58	1.00		0.20	1.00		0.65	1.00		0.58	1.00	1.00
Satd. Flow (perm)	1074	3425		376	3441		1220	3266		1080	3539	1583
Peak-hour factor, PHF	0.90	0.90	0.90	0.90	0.90	0.90	0.90	0.90	0.90	0.90	0.90	0.90
Adj. Flow (vph)	40	793	217	59	233	53	121	136	144	77	153	22
RTOR Reduction (vph)	0	55	0	0	28	0	0	74	0	0	0	14
Lane Group Flow (vph)	40	955	0	59	258	0	121	206	0	77	153	8
Turn Type	Perm			Perm			Perm			Perm		Perm
Protected Phases		4			8			2			6	
Permitted Phases	4			8			2			6		6
Actuated Green, G (s)	21.0	21.0		21.0	21.0		16.0	16.0		16.0	16.0	16.0
Effective Green, g (s)	21.0	21.0		21.0	21.0		16.0	16.0		16.0	16.0	16.0
Actuated g/C Ratio	0.47	0.47		0.47	0.47		0.36	0.36		0.36	0.36	0.36
Clearance Time (s)	4.0	4.0		4.0	4.0		4.0	4.0		4.0	4.0	4.0
Lane Grp Cap (vph)	501	1598		175	1606		434	1161		384	1258	563
v/s Ratio Prot		c0.28			0.07			0.06			0.04	
v/s Ratio Perm	0.04			0.16			c0.10			0.07		0.00
v/c Ratio	0.08	0.60		0.34	0.16		0.28	0.18		0.20	0.12	0.01
Uniform Delay, d1	6.6	8.9		7.6	6.9		10.4	10.0		10.1	9.8	9.4
Progression Factor	1.00	1.00		1.00	1.00		1.00	1.00		1.00	1.00	1.00
Incremental Delay, d2	0.3	1.7		5.1	0.2		1.6	0.3		1.2	0.2	0.0
Delay (s)	7.0	10.5		12.7	7.1		12.0	10.3		11.2	10.0	9.4
Level of Service	A	B		B	A		B	B		B	A	A
Approach Delay (s)		10.4			8.1			10.8			10.3	
Approach LOS		B			A			B			B	
<b>Intersection Summary</b>												
HCM Average Control Delay			10.1			HCM Level of Service			B			
HCM Volume to Capacity ratio			0.46									
Actuated Cycle Length (s)			45.0			Sum of lost time (s)		8.0				
Intersection Capacity Utilization			54.0%			ICU Level of Service		A				
Analysis Period (min)			15									

c Critical Lane Group

HCM Signalized Intersection Capacity Analysis  
 17: Apache Trail & Meridain Road

2025 PM  
 2/4/2013

Movement	EBL	EBT	EBR	WBL	WBT	WBR	NBL	NBT	NBR	SBL	SBT	SBR
Lane Configurations												
Volume (vph)	74	945	99	164	847	166	94	131	236	155	187	54
Ideal Flow (vphpl)	1900	1900	1900	1900	1900	1900	1900	1900	1900	1900	1900	1900
Total Lost time (s)	4.0	4.0		4.0	4.0	4.0	4.0	4.0		4.0	4.0	
Lane Util. Factor	1.00	0.91		1.00	0.91	1.00	1.00	0.95		1.00	0.95	
Flt	1.00	0.99		1.00	1.00	0.85	1.00	0.90		1.00	0.97	
Flt Protected	0.95	1.00		0.95	1.00	1.00	0.95	1.00		0.95	1.00	
Satd. Flow (prot)	1770	5013		1770	5085	1583	1770	3198		1770	3420	
Flt Permitted	0.25	1.00		0.24	1.00	1.00	0.59	1.00		0.43	1.00	
Satd. Flow (perm)	466	5013		438	5085	1583	1093	3198		805	3420	
Peak-hour factor, PHF	0.90	0.90	0.90	0.90	0.90	0.90	0.90	0.90	0.90	0.90	0.90	0.90
Adj. Flow (vph)	82	1050	110	182	941	184	104	146	262	172	208	60
RTOR Reduction (vph)	0	21	0	0	0	132	0	188	0	0	42	0
Lane Group Flow (vph)	82	1139	0	182	941	52	104	220	0	172	226	0
Turn Type	pm+pt			pm+pt		Perm	pm+pt			pm+pt		
Protected Phases	7	4		3	8		5	2		1	6	
Permitted Phases	4			8		8	2			6		
Actuated Green, G (s)	21.0	16.0		23.0	17.0	17.0	21.0	17.0		23.0	18.0	
Effective Green, g (s)	21.0	16.0		23.0	17.0	17.0	21.0	17.0		23.0	18.0	
Actuated g/C Ratio	0.35	0.27		0.38	0.28	0.28	0.35	0.28		0.38	0.30	
Clearance Time (s)	4.0	4.0		4.0	4.0	4.0	4.0	4.0		4.0	4.0	
Lane Grp Cap (vph)	272	1337		301	1441	449	428	906		389	1026	
v/s Ratio Prot	0.03	c0.23		c0.06	0.19		0.02	0.07		c0.04	0.07	
v/s Ratio Perm	0.08			0.17		0.03	0.07			c0.13		
v/c Ratio	0.30	0.85		0.60	0.65	0.12	0.24	0.24		0.44	0.22	
Uniform Delay, d1	13.5	20.9		13.8	18.9	15.9	13.5	16.5		12.7	15.7	
Progression Factor	1.00	1.00		1.00	1.00	1.00	0.88	1.04		1.00	1.00	
Incremental Delay, d2	2.8	7.0		8.7	2.3	0.5	1.2	0.6		3.6	0.5	
Delay (s)	16.4	27.9		22.5	21.2	16.5	13.0	17.8		16.3	16.2	
Level of Service	B	C		C	C	B	B	B		B	B	
Approach Delay (s)		27.1			20.7			16.8			16.3	
Approach LOS		C			C			B			B	

Intersection Summary

























HCM Average Control Delay	21.9	HCM Level of Service	C
HCM Volume to Capacity ratio	0.57		
Actuated Cycle Length (s)	60.0	Sum of lost time (s)	12.0
Intersection Capacity Utilization	62.7%	ICU Level of Service	B
Analysis Period (min)	15		

c Critical Lane Group



HCM Signalized Intersection Capacity Analysis  
 22: Broadway Avenue & Meridain Road

2025 PM  
 2/4/2013

												
Movement	EBL	EBT	EBR	WBL	WBT	WBR	NBL	NBT	NBR	SBL	SBT	SBR
Lane Configurations		 		 	 			 			 	
Volume (vph)	29	324	123	378	545	147	201	323	311	125	263	28
Ideal Flow (vphpl)	1900	1900	1900	1900	1900	1900	1900	1900	1900	1900	1900	1900
Total Lost time (s)	4.0	4.0		4.0	4.0		4.0	4.0		4.0	4.0	
Lane Util. Factor	1.00	0.95		0.97	0.95		1.00	0.95		1.00	0.95	
Flt	1.00	0.96		1.00	0.97		1.00	0.93		1.00	0.99	
Flt Protected	0.95	1.00		0.95	1.00		0.95	1.00		0.95	1.00	
Satd. Flow (prot)	1770	3393		3433	3427		1770	3279		1770	3488	
Flt Permitted	0.34	1.00		0.95	1.00		0.56	1.00		0.28	1.00	
Satd. Flow (perm)	628	3393		3433	3427		1036	3279		524	3488	
Peak-hour factor, PHF	0.90	0.90	0.90	0.90	0.90	0.90	0.90	0.90	0.90	0.90	0.90	0.90
Adj. Flow (vph)	32	360	137	420	606	163	223	359	346	139	292	31
RTOR Reduction (vph)	0	66	0	0	41	0	0	219	0	0	13	0
Lane Group Flow (vph)	32	431	0	420	728	0	223	486	0	139	310	0
Turn Type	pm+pt			Prot			Perm			Perm		
Protected Phases	7	4		3	8			2				6
Permitted Phases	4						2			6		
Actuated Green, G (s)	20.0	16.0		10.0	22.0		22.0	22.0		22.0	22.0	
Effective Green, g (s)	20.0	16.0		10.0	22.0		22.0	22.0		22.0	22.0	
Actuated g/C Ratio	0.33	0.27		0.17	0.37		0.37	0.37		0.37	0.37	
Clearance Time (s)	4.0	4.0		4.0	4.0		4.0	4.0		4.0	4.0	
Lane Grp Cap (vph)	285	905		572	1257		380	1202		192	1279	
v/s Ratio Prot	0.01	0.13		c0.12	c0.21			0.15			0.09	
v/s Ratio Perm	0.03						0.22			c0.27		
v/c Ratio	0.11	0.48		0.73	0.58		0.59	0.40		0.72	0.24	
Uniform Delay, d1	13.6	18.5		23.7	15.3		15.3	14.1		16.4	13.2	
Progression Factor	1.00	1.00		1.00	1.00		0.98	1.16		0.94	0.98	
Incremental Delay, d2	0.8	1.8		8.1	2.0		5.9	0.9		18.6	0.4	
Delay (s)	14.4	20.3		31.9	17.2		20.9	17.4		34.0	13.4	
Level of Service	B	C		C	B		C	B		C	B	
Approach Delay (s)		19.9			22.4			18.2			19.6	
Approach LOS		B			C			B			B	



























Intersection Summary		
HCM Average Control Delay	20.3	HCM Level of Service C
HCM Volume to Capacity ratio	0.65	
Actuated Cycle Length (s)	60.0	Sum of lost time (s) 8.0
Intersection Capacity Utilization	62.8%	ICU Level of Service B
Analysis Period (min)	15	

c Critical Lane Group

# HCM Signalized Intersection Capacity Analysis

## 27: Southern Avenue & Meridain Road













2025 PM  
2/4/2013

												
Movement	EBL	EBT	EBR	WBL	WBT	WBR	NBL	NBT	NBR	SBL	SBT	SBR
Lane Configurations		 			 		 	 			 	
Volume (vph)	238	215	129	210	206	113	259	489	338	17	720	26
Ideal Flow (vphpl)	1900	1900	1900	1900	1900	1900	1900	1900	1900	1900	1900	1900
Total Lost time (s)	4.0	4.0		4.0	4.0		4.0	4.0	4.0	4.0	4.0	
Lane Util. Factor	1.00	0.95		1.00	0.95		0.97	0.95	1.00	1.00	0.95	
Flt	1.00	0.94		1.00	0.95		1.00	1.00	0.85	1.00	0.99	
Flt Protected	0.95	1.00		0.95	1.00		0.95	1.00	1.00	0.95	1.00	
Satd. Flow (prot)	1770	3340		1770	3351		3433	3539	1583	1770	3521	
Flt Permitted	0.40	1.00		0.53	1.00		0.95	1.00	1.00	0.45	1.00	
Satd. Flow (perm)	752	3340		979	3351		3433	3539	1583	837	3521	
Peak-hour factor, PHF	0.90	0.90	0.90	0.90	0.90	0.90	0.90	0.90	0.90	0.90	0.90	0.90
Adj. Flow (vph)	264	239	143	233	229	126	288	543	376	19	800	29
RTOR Reduction (vph)	0	85	0	0	92	0	0	0	232	0	4	0
Lane Group Flow (vph)	264	297	0	233	263	0	288	543	144	19	825	0
Turn Type	pm+pt			Perm			Prot			Perm	pm+pt	
Protected Phases	7	4			8		5	2			1	6
Permitted Phases	4			8						2	6	
Actuated Green, G (s)	24.2	24.2		16.2	16.2		6.4	23.0	23.0	18.2	17.4	
Effective Green, g (s)	24.2	24.2		16.2	16.2		6.4	23.0	23.0	18.2	17.4	
Actuated g/C Ratio	0.40	0.40		0.27	0.27		0.11	0.38	0.38	0.30	0.29	
Clearance Time (s)	4.0	4.0		4.0	4.0		4.0	4.0	4.0	4.0	4.0	
Vehicle Extension (s)	3.0	3.0		3.0	3.0		3.0	3.0	3.0	3.0	3.0	
Lane Grp Cap (vph)	371	1347		264	905		366	1357	607	266	1021	
v/s Ratio Prot	c0.05	0.09			0.08		c0.08	0.15		0.00	c0.23	
v/s Ratio Perm	0.24			c0.24					0.09	0.02		
v/c Ratio	0.71	0.22		0.88	0.29		0.79	0.40	0.24	0.07	0.81	
Uniform Delay, d1	14.6	11.7		21.0	17.3		26.1	13.5	12.6	14.7	19.7	
Progression Factor	1.00	1.00		1.00	1.00		1.14	0.85	0.62	0.68	0.60	
Incremental Delay, d2	6.3	0.1		27.3	0.2		10.6	0.9	0.9	0.1	5.9	
Delay (s)	20.9	11.8		48.3	17.5		40.5	12.3	8.8	10.1	17.9	
Level of Service	C	B		D	B		D	B	A	B	B	
Approach Delay (s)		15.5			29.7			17.9			17.7	
Approach LOS		B			C			B			B	
<b>Intersection Summary</b>												
HCM Average Control Delay			19.5			HCM Level of Service			B			
HCM Volume to Capacity ratio			0.83									
Actuated Cycle Length (s)			60.0			Sum of lost time (s)			16.0			
Intersection Capacity Utilization			64.0%			ICU Level of Service			B			
Analysis Period (min)			15									
c Critical Lane Group												

# HCM Signalized Intersection Capacity Analysis

## 68: US 60 WB On-Ramp & Meridain Road

2025 PM  
2/4/2013

						
Movement	EBL	EBR	NBL	NBT	SBT	SBR
Lane Configurations			 	 	 	
Volume (vph)	0	0	341	564	546	245
Ideal Flow (vphpl)	1900	1900	1900	1900	1900	1900
Total Lost time (s)			4.0	4.0	4.0	4.0
Lane Util. Factor			0.97	0.95	0.95	1.00
Frt			1.00	1.00	1.00	0.85
Flt Protected			0.95	1.00	1.00	1.00
Satd. Flow (prot)			3433	3539	3539	1583
Flt Permitted			0.11	1.00	1.00	1.00
Satd. Flow (perm)			401	3539	3539	1583
Peak-hour factor, PHF	0.90	0.90	0.90	0.90	0.90	0.90
Adj. Flow (vph)	0	0	379	627	607	272
RTOR Reduction (vph)	0	0	0	0	0	199
Lane Group Flow (vph)	0	0	379	627	607	73
Turn Type			pm+pt			Perm
Protected Phases			2	5 6	6	
Permitted Phases			5 6			6
Actuated Green, G (s)			56.0	60.0	16.0	16.0
Effective Green, g (s)			56.0	60.0	16.0	16.0
Actuated g/C Ratio			0.93	1.00	0.27	0.27
Clearance Time (s)			4.0		4.0	4.0
Lane Grp Cap (vph)			1183	3539	944	422
v/s Ratio Prot			c0.09	0.18	c0.17	
v/s Ratio Perm			c0.21			0.05
v/c Ratio			0.32	0.18	0.64	0.17
Uniform Delay, d1			9.8	0.0	19.5	16.9
Progression Factor			0.52	1.00	0.88	2.08
Incremental Delay, d2			0.7	0.1	2.2	0.6
Delay (s)			5.7	0.1	19.3	35.7
Level of Service			A	A	B	D
Approach Delay (s)	0.0			2.2	24.4	
Approach LOS	A			A	C	
<b>Intersection Summary</b>						
HCM Average Control Delay			12.6	HCM Level of Service		B
HCM Volume to Capacity ratio			0.42			
Actuated Cycle Length (s)			60.0	Sum of lost time (s)		8.0
Intersection Capacity Utilization			77.4%	ICU Level of Service		D
Analysis Period (min)			15			
c Critical Lane Group						

# HCM Signalized Intersection Capacity Analysis

## 71: US 60 EB Off-Ramp & Meridain Road

2025 PM  
2/4/2013



Movement	EBL	EBR	NBL	NBT	SBT	SBR
Lane Configurations	↶	↷		↶↷	↶↷	
Volume (vph)	380	1204	0	525	546	0
Ideal Flow (vphpl)	1900	1900	1900	1900	1900	1900
Grade (%)	1%			0%	0%	
Total Lost time (s)	4.0	4.0		4.0	4.0	
Lane Util. Factor	1.00	0.88		0.91	0.95	
Frt	1.00	0.85		1.00	1.00	
Flt Protected	0.95	1.00		1.00	1.00	
Satd. Flow (prot)	1761	2773		5085	3539	
Flt Permitted	0.95	1.00		1.00	1.00	
Satd. Flow (perm)	1761	2773		5085	3539	
Peak-hour factor, PHF	0.90	0.90	0.90	0.90	0.90	0.90
Adj. Flow (vph)	422	1338	0	583	607	0
RTOR Reduction (vph)	0	36	0	0	0	0
Lane Group Flow (vph)	422	1302	0	583	607	0
Turn Type	Perm					
Protected Phases	4 12			2	2	
Permitted Phases		4 12				
Actuated Green, G (s)	36.0	36.0		16.0	16.0	
Effective Green, g (s)	36.0	36.0		16.0	16.0	
Actuated g/C Ratio	0.60	0.60		0.27	0.27	
Clearance Time (s)				4.0	4.0	
Lane Grp Cap (vph)	1057	1664		1356	944	
v/s Ratio Prot	0.24			0.11	c0.17	
v/s Ratio Perm		c0.47				
v/c Ratio	0.40	0.78		0.43	0.64	
Uniform Delay, d1	6.3	9.0		18.2	19.5	
Progression Factor	1.00	1.00		0.93	0.76	
Incremental Delay, d2	1.1	3.7		0.9	2.6	
Delay (s)	7.4	12.8		17.8	17.3	
Level of Service	A	B		B	B	
Approach Delay (s)	11.5			17.8	17.3	
Approach LOS	B			B	B	

### Intersection Summary

HCM Average Control Delay	13.9	HCM Level of Service	B
HCM Volume to Capacity ratio	0.74		
Actuated Cycle Length (s)	60.0	Sum of lost time (s)	8.0
Intersection Capacity Utilization	77.4%	ICU Level of Service	D
Analysis Period (min)	15		
c Critical Lane Group			

HCM Signalized Intersection Capacity Analysis  
31: Baseline Road & Meridain Road

























2025 PM  
2/4/2013

Movement	EBL	EBT	EBR	WBL	WBT	WBR	NBL	NBT	NBR	SBL	SBT	SBR
Lane Configurations												
Volume (vph)	73	538	91	60	219	469	58	663	252	176	629	16
Ideal Flow (vphpl)	1900	1900	1900	1900	1900	1900	1900	1900	1900	1900	1900	1900
Total Lost time (s)	4.0	4.0		4.0	4.0	4.0	4.0	4.0		4.0	4.0	4.0
Lane Util. Factor	1.00	0.95		1.00	0.95	0.88	1.00	0.91		1.00	0.95	1.00
Flt	1.00	0.98		1.00	1.00	0.85	1.00	0.96		1.00	1.00	0.85
Flt Protected	0.95	1.00		0.95	1.00	1.00	0.95	1.00		0.95	1.00	1.00
Satd. Flow (prot)	1770	3463		1770	3539	2787	1770	4875		1770	3539	1583
Flt Permitted	0.60	1.00		0.26	1.00	1.00	0.39	1.00		0.17	1.00	1.00
Satd. Flow (perm)	1119	3463		490	3539	2787	719	4875		317	3539	1583
Peak-hour factor, PHF	0.90	0.90	0.90	0.90	0.90	0.90	0.90	0.90	0.90	0.90	0.90	0.90
Adj. Flow (vph)	81	598	101	67	243	521	64	737	280	196	699	18
RTOR Reduction (vph)	0	23	0	0	0	178	0	107	0	0	0	9
Lane Group Flow (vph)	81	676	0	67	243	343	64	910	0	196	699	9
Turn Type	pm+pt			pm+pt		pm+ov	Perm			pm+pt		Perm
Protected Phases	7	4		3	8	1		2		1	6	
Permitted Phases	4			8		8	2			6		6
Actuated Green, G (s)	17.6	15.2		17.6	15.2	22.1	19.5	19.5		30.4	30.4	30.4
Effective Green, g (s)	17.6	15.2		17.6	15.2	22.1	19.5	19.5		30.4	30.4	30.4
Actuated g/C Ratio	0.29	0.25		0.29	0.25	0.37	0.32	0.32		0.51	0.51	0.51
Clearance Time (s)	4.0	4.0		4.0	4.0	4.0	4.0	4.0		4.0	4.0	4.0
Vehicle Extension (s)	3.0	3.0		3.0	3.0	3.0	3.0	3.0		3.0	3.0	3.0
Lane Grp Cap (vph)	354	877		195	897	1212	234	1584		328	1793	802
v/s Ratio Prot	0.01	c0.20		c0.01	0.07	0.03		0.19		c0.07	0.20	
v/s Ratio Perm	0.06			0.09		0.09	0.09			c0.23		0.01
v/c Ratio	0.23	0.77		0.34	0.27	0.28	0.27	0.57		0.60	0.39	0.01
Uniform Delay, d1	15.7	20.8		16.1	18.0	13.4	15.0	16.8		9.6	9.1	7.3
Progression Factor	1.00	1.00		1.00	1.00	1.00	1.00	1.00		0.99	0.91	0.92
Incremental Delay, d2	0.3	4.2		1.1	0.2	0.1	2.9	1.5		1.9	0.4	0.0
Delay (s)	16.0	25.0		17.1	18.1	13.5	17.9	18.3		11.4	8.7	6.8
Level of Service	B	C		B	B	B	B	B		B	A	A
Approach Delay (s)		24.1			15.1			18.3			9.3	
Approach LOS		C			B			B			A	
<b>Intersection Summary</b>												
HCM Average Control Delay			16.5				HCM Level of Service				B	
HCM Volume to Capacity ratio			0.62									
Actuated Cycle Length (s)			60.0				Sum of lost time (s)			12.0		
Intersection Capacity Utilization			62.6%				ICU Level of Service			B		
Analysis Period (min)			15									
c Critical Lane Group												



HCM Signalized Intersection Capacity Analysis  
2: Guadalupe Road & Meridian Road

2025 PM  
2/4/2013

												
Movement	EBL	EBT	EBR	WBL	WBT	WBR	NBL	NBT	NBR	SBL	SBT	SBR
Lane Configurations		 			 			 			 	
Volume (vph)	261	1307	174	113	563	79	4	55	15	124	630	75
Ideal Flow (vphpl)	1900	1900	1900	1900	1900	1900	1900	1900	1900	1900	1900	1900
Total Lost time (s)	4.0	4.0		4.0	4.0		4.0	4.0		4.0	4.0	
Lane Util. Factor	1.00	0.95		1.00	0.95		1.00	0.95		1.00	0.95	
Frt	1.00	0.98		1.00	0.98		1.00	0.97		1.00	0.98	
Flt Protected	0.95	1.00		0.95	1.00		0.95	1.00		0.95	1.00	
Satd. Flow (prot)	1770	3477		1770	3474		1770	3424		1770	3483	
Flt Permitted	0.21	1.00		0.18	1.00		0.24	1.00		0.70	1.00	
Satd. Flow (perm)	399	3477		339	3474		438	3424		1311	3483	
Peak-hour factor, PHF	0.90	0.90	0.90	0.90	0.90	0.90	0.90	0.90	0.90	0.90	0.90	0.90
Adj. Flow (vph)	290	1452	193	126	626	88	4	61	17	138	700	83
RTOR Reduction (vph)	0	16	0	0	17	0	0	13	0	0	14	0
Lane Group Flow (vph)	290	1629	0	126	697	0	4	65	0	138	769	0
Turn Type	pm+pt			pm+pt			Perm			Perm		
Protected Phases	7	4		3	8			2				6
Permitted Phases	4			8			2			6		
Actuated Green, G (s)	40.0	32.0		26.0	22.0		17.0	17.0		17.0	17.0	
Effective Green, g (s)	40.0	32.0		26.0	22.0		17.0	17.0		17.0	17.0	
Actuated g/C Ratio	0.62	0.49		0.40	0.34		0.26	0.26		0.26	0.26	
Clearance Time (s)	4.0	4.0		4.0	4.0		4.0	4.0		4.0	4.0	
Lane Grp Cap (vph)	541	1712		224	1176		115	896		343	911	
v/s Ratio Prot	c0.12	c0.47		0.03	0.20			0.02			c0.22	
v/s Ratio Perm	0.21			0.19			0.01			0.11		
v/c Ratio	0.54	0.95		0.56	0.59		0.03	0.07		0.40	0.84	
Uniform Delay, d1	7.4	15.8		14.9	17.8		17.9	18.1		19.8	22.7	
Progression Factor	1.00	1.00		1.00	1.00		1.00	1.00		1.00	1.00	
Incremental Delay, d2	3.8	13.0		9.8	2.2		0.6	0.2		3.5	9.4	
Delay (s)	11.2	28.7		24.8	20.0		18.4	18.2		23.3	32.2	
Level of Service	B	C		C	B		B	B		C	C	
Approach Delay (s)		26.1			20.7			18.2			30.8	
Approach LOS		C			C			B			C	

Intersection Summary

























HCM Average Control Delay	25.9	HCM Level of Service	C
HCM Volume to Capacity ratio	0.90		
Actuated Cycle Length (s)	65.0	Sum of lost time (s)	12.0
Intersection Capacity Utilization	77.7%	ICU Level of Service	D
Analysis Period (min)	15		

c Critical Lane Group

# HCM Signalized Intersection Capacity Analysis























## 35: Elliot Road & Meridian Road

2025 PM  
2/4/2013

												
Movement	EBL	EBT	EBR	WBL	WBT	WBR	NBL	NBT	NBR	SBL	SBT	SBR
Lane Configurations		 			 			 			 	
Volume (vph)	176	880	117	100	593	77	35	473	118	92	681	144
Ideal Flow (vphpl)	1900	1900	1900	1900	1900	1900	1900	1900	1900	1900	1900	1900
Total Lost time (s)	4.0	4.0		4.0	4.0		4.0	4.0		4.0	4.0	
Lane Util. Factor	1.00	0.91		1.00	0.91		0.97	0.95		1.00	0.95	
Flt	1.00	0.98		1.00	0.98		1.00	0.97		1.00	0.97	
Flt Protected	0.95	1.00		0.95	1.00		0.95	1.00		0.95	1.00	
Satd. Flow (prot)	1770	4996		1770	4997		3433	3433		1770	3447	
Flt Permitted	0.22	1.00		0.25	1.00		0.95	1.00		0.25	1.00	
Satd. Flow (perm)	415	4996		475	4997		3433	3433		461	3447	
Peak-hour factor, PHF	0.90	0.90	0.90	0.90	0.90	0.90	0.90	0.90	0.90	0.90	0.90	0.90
Adj. Flow (vph)	196	978	130	111	659	86	39	526	131	102	757	160
RTOR Reduction (vph)	0	28	0	0	28	0	0	35	0	0	27	0
Lane Group Flow (vph)	196	1080	0	111	717	0	39	622	0	102	890	0
Turn Type	pm+pt			pm+pt			Prot			pm+pt		
Protected Phases	7	4		3	8		5	2		1	6	
Permitted Phases	4			8						6		
Actuated Green, G (s)	24.8	18.7		18.8	15.7		1.5	19.0		25.1	21.3	
Effective Green, g (s)	24.8	18.7		18.8	15.7		1.5	19.0		25.1	21.3	
Actuated g/C Ratio	0.41	0.31		0.31	0.26		0.02	0.31		0.41	0.35	
Clearance Time (s)	4.0	4.0		4.0	4.0		4.0	4.0		4.0	4.0	
Vehicle Extension (s)	3.0	3.0		3.0	3.0		3.0	3.0		3.0	3.0	
Lane Grp Cap (vph)	306	1542		214	1295		85	1076		273	1212	
v/s Ratio Prot	c0.06	c0.22		0.03	0.14		0.01	0.18		c0.02	c0.26	
v/s Ratio Perm	0.20			0.13						0.13		
v/c Ratio	0.64	0.70		0.52	0.55		0.46	0.58		0.37	0.73	
Uniform Delay, d1	12.5	18.5		15.6	19.4		29.1	17.4		11.7	17.2	
Progression Factor	1.00	1.00		1.00	1.00		1.00	1.00		1.00	1.00	
Incremental Delay, d2	4.5	1.5		2.1	0.5		3.9	2.3		0.9	4.0	
Delay (s)	17.0	19.9		17.8	19.9		33.0	19.7		12.5	21.1	
Level of Service	B	B		B	B		C	B		B	C	
Approach Delay (s)		19.5			19.7			20.5			20.3	
Approach LOS		B			B			C			C	
<b>Intersection Summary</b>												
HCM Average Control Delay			19.9			HCM Level of Service				B		
HCM Volume to Capacity ratio			0.76									
Actuated Cycle Length (s)			60.6			Sum of lost time (s)			16.0			
Intersection Capacity Utilization			65.2%			ICU Level of Service				C		
Analysis Period (min)			15									
c Critical Lane Group												























HCM Signalized Intersection Capacity Analysis  
 37: Warner Road & Meridian Road

2025 PM  
 2/4/2013

												
Movement	EBL	EBT	EBR	WBL	WBT	WBR	NBL	NBT	NBR	SBL	SBT	SBR
Lane Configurations												
Volume (vph)	428	2072	270	144	711	106	12	61	4	17	86	11
Ideal Flow (vphpl)	1900	1900	1900	1900	1900	1900	1900	1900	1900	1900	1900	1900
Total Lost time (s)	4.0	4.0	4.0	4.0	4.0		4.0	4.0		4.0	4.0	
Lane Util. Factor	0.97	0.91	1.00	1.00	0.91		1.00	0.95		1.00	0.95	
Frt	1.00	1.00	0.85	1.00	0.98		1.00	0.99		1.00	0.98	
Flt Protected	0.95	1.00	1.00	0.95	1.00		0.95	1.00		0.95	1.00	
Satd. Flow (prot)	3433	5085	1583	1770	4986		1770	3510		1770	3480	
Flt Permitted	0.95	1.00	1.00	0.16	1.00		0.68	1.00		0.68	1.00	
Satd. Flow (perm)	3433	5085	1583	304	4986		1274	3510		1263	3480	
Peak-hour factor, PHF	0.90	0.90	0.90	0.90	0.90	0.90	0.90	0.90	0.90	0.90	0.90	0.90
Adj. Flow (vph)	476	2302	300	160	790	118	13	68	4	19	96	12
RTOR Reduction (vph)	0	0	119	0	26	0	0	3	0	0	9	0
Lane Group Flow (vph)	476	2302	181	160	882	0	13	69	0	19	99	0
Turn Type	Prot		Perm	pm+pt			pm+pt			pm+pt		
Protected Phases	7	4		3	8		5	2		1	6	
Permitted Phases			4	8			2			6		
Actuated Green, G (s)	14.5	35.0	35.0	28.5	24.5		19.2	18.4		20.8	19.2	
Effective Green, g (s)	14.5	35.0	35.0	28.5	24.5		19.2	18.4		20.8	19.2	
Actuated g/C Ratio	0.19	0.47	0.47	0.38	0.33		0.26	0.25		0.28	0.26	
Clearance Time (s)	4.0	4.0	4.0	4.0	4.0		4.0	4.0		4.0	4.0	
Vehicle Extension (s)	3.0	3.0	3.0	3.0	3.0		3.0	3.0		3.0	3.0	
Lane Grp Cap (vph)	664	2373	739	194	1629		331	861		361	891	
v/s Ratio Prot	c0.14	c0.45		0.04	0.18		0.00	0.02		c0.00	c0.03	
v/s Ratio Perm			0.11	0.27			0.01			0.01		
v/c Ratio	0.72	0.97	0.24	0.82	0.54		0.04	0.08		0.05	0.11	
Uniform Delay, d1	28.3	19.5	12.0	20.8	20.7		20.9	21.8		19.8	21.4	
Progression Factor	1.00	1.00	1.00	1.00	1.00		1.00	1.00		1.00	1.00	
Incremental Delay, d2	3.7	12.3	0.2	23.9	0.4		0.0	0.2		0.1	0.3	
Delay (s)	32.0	31.7	12.2	44.6	21.0		21.0	22.0		19.9	21.6	
Level of Service	C	C	B	D	C		C	C		B	C	
Approach Delay (s)		29.9			24.6			21.8			21.4	
Approach LOS		C			C			C			C	
<b>Intersection Summary</b>												
HCM Average Control Delay			28.2			HCM Level of Service				C		
HCM Volume to Capacity ratio			0.64									
Actuated Cycle Length (s)			75.0			Sum of lost time (s)			12.0			
Intersection Capacity Utilization			65.6%			ICU Level of Service				C		
Analysis Period (min)			15									
c Critical Lane Group												





















HCM Signalized Intersection Capacity Analysis  
41: Ray Road & Meridian Road

2025 PM  
2/4/2013

												
Movement	EBL	EBT	EBR	WBL	WBT	WBR	NBL	NBT	NBR	SBL	SBT	SBR
Lane Configurations												
Volume (vph)	302	1474	250	78	930	543	34	190	56	85	179	29
Ideal Flow (vphpl)	1900	1900	1900	1900	1900	1900	1900	1900	1900	1900	1900	1900
Total Lost time (s)	4.0	4.0		4.0	4.0	4.0	4.0	4.0		4.0	4.0	
Lane Util. Factor	0.97	0.91		0.97	0.91	1.00	1.00	0.95		1.00	0.95	
Flt	1.00	0.98		1.00	1.00	0.85	1.00	0.97		1.00	0.98	
Flt Protected	0.95	1.00		0.95	1.00	1.00	0.95	1.00		0.95	1.00	
Satd. Flow (prot)	3433	4975		3433	5085	1583	1770	3419		1770	3466	
Flt Permitted	0.95	1.00		0.95	1.00	1.00	0.61	1.00		0.58	1.00	
Satd. Flow (perm)	3433	4975		3433	5085	1583	1132	3419		1087	3466	
Peak-hour factor, PHF	0.90	0.90	0.90	0.90	0.90	0.90	0.90	0.90	0.90	0.90	0.90	0.90
Adj. Flow (vph)	336	1638	278	87	1033	603	38	211	62	94	199	32
RTOR Reduction (vph)	0	36	0	0	0	186	0	46	0	0	24	0
Lane Group Flow (vph)	336	1880	0	87	1033	417	38	227	0	94	207	0
Turn Type	Prot			Prot		Perm	Perm			Perm		
Protected Phases	7	4		3	8			2				6
Permitted Phases						8	2			6		
Actuated Green, G (s)	7.0	24.1		4.5	21.6	21.6	14.4	14.4		14.4	14.4	
Effective Green, g (s)	7.0	24.1		4.5	21.6	21.6	14.4	14.4		14.4	14.4	
Actuated g/C Ratio	0.13	0.44		0.08	0.39	0.39	0.26	0.26		0.26	0.26	
Clearance Time (s)	4.0	4.0		4.0	4.0	4.0	4.0	4.0		4.0	4.0	
Vehicle Extension (s)	3.0	3.0		3.0	3.0	3.0	3.0	3.0		3.0	3.0	
Lane Grp Cap (vph)	437	2180		281	1997	622	296	895		285	907	
v/s Ratio Prot	c0.10	c0.38		0.03	0.20			0.07			0.06	
v/s Ratio Perm						0.26	0.03			c0.09		
v/c Ratio	0.77	0.86		0.31	0.52	0.67	0.13	0.25		0.33	0.23	
Uniform Delay, d1	23.2	14.0		23.8	12.7	13.8	15.5	16.1		16.4	15.9	
Progression Factor	1.00	1.00		1.00	1.00	1.00	1.00	1.00		1.00	1.00	
Incremental Delay, d2	7.9	3.8		0.6	0.2	2.7	0.9	0.7		3.1	0.6	
Delay (s)	31.2	17.7		24.4	13.0	16.5	16.4	16.7		19.5	16.5	
Level of Service	C	B		C	B	B	B	B		B	B	
Approach Delay (s)		19.7			14.8			16.7			17.4	
Approach LOS		B			B			B			B	
<b>Intersection Summary</b>												
HCM Average Control Delay			17.5									B
HCM Volume to Capacity ratio			0.64									
Actuated Cycle Length (s)			55.0								8.0	
Intersection Capacity Utilization			62.5%									B
Analysis Period (min)			15									
c Critical Lane Group												

HCM Signalized Intersection Capacity Analysis  
58: Williams Field Road & Meridian Road

2025 PM  
2/4/2013

























												
Movement	EBL	EBT	EBR	WBL	WBT	WBR	NBL	NBT	NBR	SBL	SBT	SBR
Lane Configurations												
Volume (vph)	378	647	195	106	503	240	199	599	249	169	304	90
Ideal Flow (vphpl)	1900	1900	1900	1900	1900	1900	1900	1900	1900	1900	1900	1900
Total Lost time (s)	4.0	4.0		4.0	4.0		4.0	4.0		4.0	4.0	
Lane Util. Factor	0.97	0.91		0.97	0.91		1.00	0.95		1.00	0.95	
Frt	1.00	0.97		1.00	0.95		1.00	0.96		1.00	0.97	
Flt Protected	0.95	1.00		0.95	1.00		0.95	1.00		0.95	1.00	
Satd. Flow (prot)	3433	4908		3433	4839		1770	3383		1770	3418	
Flt Permitted	0.95	1.00		0.95	1.00		0.42	1.00		0.25	1.00	
Satd. Flow (perm)	3433	4908		3433	4839		784	3383		475	3418	
Peak-hour factor, PHF	0.90	0.90	0.90	0.90	0.90	0.90	0.90	0.90	0.90	0.90	0.90	0.90
Adj. Flow (vph)	420	719	217	118	559	267	221	666	277	188	338	100
RTOR Reduction (vph)	0	91	0	0	148	0	0	76	0	0	46	0
Lane Group Flow (vph)	420	845	0	118	678	0	221	867	0	188	392	0
Turn Type	Prot			Prot			pm+pt			pm+pt		
Protected Phases	7	4		3	8		5	2		1	6	
Permitted Phases							2			6		
Actuated Green, G (s)	8.0	19.0		4.0	15.0		20.9	15.6		21.1	15.7	
Effective Green, g (s)	8.0	19.0		4.0	15.0		20.9	15.6		21.1	15.7	
Actuated g/C Ratio	0.13	0.32		0.07	0.25		0.35	0.26		0.35	0.26	
Clearance Time (s)	4.0	4.0		4.0	4.0		4.0	4.0		4.0	4.0	
Vehicle Extension (s)	3.0	3.0		3.0	3.0		3.0	3.0		3.0	3.0	
Lane Grp Cap (vph)	458	1554		229	1210		360	880		284	894	
v/s Ratio Prot	c0.12	c0.17		0.03	0.14		0.05	c0.26		c0.06	0.11	
v/s Ratio Perm							0.16			0.17		
v/c Ratio	0.92	0.54		0.52	0.56		0.61	0.98		0.66	0.44	
Uniform Delay, d1	25.7	16.9		27.1	19.6		14.7	22.1		15.4	18.5	
Progression Factor	1.00	1.00		1.00	1.00		1.00	1.00		1.00	1.00	
Incremental Delay, d2	23.0	0.4		2.0	0.6		3.1	26.9		5.7	1.6	
Delay (s)	48.7	17.3		29.0	20.2		17.8	49.0		21.1	20.0	
Level of Service	D	B		C	C		B	D		C	C	
Approach Delay (s)		27.0			21.3			43.1			20.3	
Approach LOS		C			C			D			C	
<b>Intersection Summary</b>												
HCM Average Control Delay			29.3			HCM Level of Service				C		
HCM Volume to Capacity ratio			0.78									
Actuated Cycle Length (s)			60.0			Sum of lost time (s)			16.0			
Intersection Capacity Utilization			73.1%			ICU Level of Service				D		
Analysis Period (min)			15									
c Critical Lane Group												



# HCM Signalized Intersection Capacity Analysis

## 60: Pecos Road & Meridian Road

2025 PM  
2/4/2013

												
Movement	EBL	EBT	EBR	WBL	WBT	WBR	NBL	NBT	NBR	SBL	SBT	SBR
Lane Configurations		 			 			 			 	
Volume (vph)	103	514	69	100	701	312	37	594	111	194	829	54
Ideal Flow (vphpl)	1900	1900	1900	1900	1900	1900	1900	1900	1900	1900	1900	1900
Total Lost time (s)	4.0	4.0		4.0	4.0		4.0	4.0		4.0	4.0	
Lane Util. Factor	1.00	0.95		1.00	0.95		1.00	0.95		1.00	0.95	
Flt	1.00	0.98		1.00	0.95		1.00	0.98		1.00	0.99	
Flt Protected	0.95	1.00		0.95	1.00		0.95	1.00		0.95	1.00	
Satd. Flow (prot)	1770	3476		1770	3376		1770	3456		1770	3507	
Flt Permitted	0.22	1.00		0.33	1.00		0.29	1.00		0.20	1.00	
Satd. Flow (perm)	414	3476		609	3376		544	3456		373	3507	
Peak-hour factor, PHF	0.90	0.90	0.90	0.90	0.90	0.90	0.90	0.90	0.90	0.90	0.90	0.90
Adj. Flow (vph)	114	571	77	111	779	347	41	660	123	216	921	60
RTOR Reduction (vph)	0	21	0	0	102	0	0	31	0	0	9	0
Lane Group Flow (vph)	114	627	0	111	1024	0	41	752	0	216	972	0
Turn Type	Perm			Perm			Perm			pm+pt		
Protected Phases		4			8			2		1	6	
Permitted Phases	4			8			2			6		
Actuated Green, G (s)	18.0	18.0		18.0	18.0		16.0	16.0		24.0	24.0	
Effective Green, g (s)	18.0	18.0		18.0	18.0		16.0	16.0		24.0	24.0	
Actuated g/C Ratio	0.36	0.36		0.36	0.36		0.32	0.32		0.48	0.48	
Clearance Time (s)	4.0	4.0		4.0	4.0		4.0	4.0		4.0	4.0	
Lane Grp Cap (vph)	149	1251		219	1215		174	1106		291	1683	
v/s Ratio Prot		0.18			c0.30			0.22		c0.06	0.28	
v/s Ratio Perm	0.28			0.18			0.08			c0.30		
v/c Ratio	0.77	0.50		0.51	0.84		0.24	0.68		0.74	0.58	
Uniform Delay, d1	14.1	12.5		12.5	14.7		12.5	14.8		9.1	9.4	
Progression Factor	1.00	1.00		1.00	1.00		1.00	1.00		1.00	1.00	
Incremental Delay, d2	30.5	1.4		8.1	7.2		3.2	3.4		15.7	1.4	
Delay (s)	44.7	13.9		20.7	21.9		15.7	18.2		24.8	10.8	
Level of Service	D	B		C	C		B	B		C	B	
Approach Delay (s)		18.5			21.8			18.0			13.3	
Approach LOS		B			C			B			B	

### Intersection Summary

























HCM Average Control Delay	17.9	HCM Level of Service	B
HCM Volume to Capacity ratio	0.76		
Actuated Cycle Length (s)	50.0	Sum of lost time (s)	8.0
Intersection Capacity Utilization	79.1%	ICU Level of Service	D
Analysis Period (min)	15		

c Critical Lane Group

# HCM Signalized Intersection Capacity Analysis

## 50: Germann Road & Meridian Road

2025 PM  
2/4/2013

												
Movement	EBL	EBT	EBR	WBL	WBT	WBR	NBL	NBT	NBR	SBL	SBT	SBR
Lane Configurations		 			 			 			 	
Volume (vph)	148	995	202	81	309	126	45	505	17	56	451	111
Ideal Flow (vphpl)	1900	1900	1900	1900	1900	1900	1900	1900	1900	1900	1900	1900
Total Lost time (s)	4.0	4.0		4.0	4.0		4.0	4.0		4.0	4.0	
Lane Util. Factor	1.00	0.95		1.00	0.95		1.00	0.95		1.00	0.95	
Flt	1.00	0.97		1.00	0.96		1.00	1.00		1.00	0.97	
Flt Protected	0.95	1.00		0.95	1.00		0.95	1.00		0.95	1.00	
Satd. Flow (prot)	1770	3450		1770	3385		1770	3522		1770	3435	
Flt Permitted	0.38	1.00		0.17	1.00		0.42	1.00		0.22	1.00	
Satd. Flow (perm)	713	3450		324	3385		774	3522		403	3435	
Peak-hour factor, PHF	0.90	0.90	0.90	0.90	0.90	0.90	0.90	0.90	0.90	0.90	0.90	0.90
Adj. Flow (vph)	164	1106	224	90	343	140	50	561	19	62	501	123
RTOR Reduction (vph)	0	26	0	0	68	0	0	4	0	0	33	0
Lane Group Flow (vph)	164	1304	0	90	415	0	50	576	0	62	591	0
Turn Type	pm+pt			pm+pt			Perm			pm+pt		
Protected Phases	7	4		3	8			2		1	6	
Permitted Phases	4			8			2			6		
Actuated Green, G (s)	31.0	25.0		27.0	23.0		16.0	16.0		24.0	24.0	
Effective Green, g (s)	31.0	25.0		27.0	23.0		16.0	16.0		24.0	24.0	
Actuated g/C Ratio	0.48	0.38		0.42	0.35		0.25	0.25		0.37	0.37	
Clearance Time (s)	4.0	4.0		4.0	4.0		4.0	4.0		4.0	4.0	
Lane Grp Cap (vph)	438	1327		224	1198		191	867		233	1268	
v/s Ratio Prot	c0.03	c0.38		0.02	0.12			c0.16		0.02	c0.17	
v/s Ratio Perm	0.14			0.14			0.06			0.08		
v/c Ratio	0.37	0.98		0.40	0.35		0.26	0.66		0.27	0.47	
Uniform Delay, d1	10.0	19.8		14.6	15.5		19.7	22.1		14.2	15.6	
Progression Factor	1.00	1.00		1.00	1.00		1.00	1.00		1.00	1.00	
Incremental Delay, d2	2.4	20.9		5.3	0.8		3.3	4.0		2.8	1.2	
Delay (s)	12.5	40.7		19.9	16.3		23.1	26.1		17.0	16.8	
Level of Service	B	D		B	B		C	C		B	B	
Approach Delay (s)		37.6			16.8			25.8			16.9	
Approach LOS		D			B			C			B	

























### Intersection Summary

HCM Average Control Delay	27.7	HCM Level of Service	C
HCM Volume to Capacity ratio	0.82		
Actuated Cycle Length (s)	65.0	Sum of lost time (s)	16.0
Intersection Capacity Utilization	71.1%	ICU Level of Service	C
Analysis Period (min)	15		

c Critical Lane Group

HCM Signalized Intersection Capacity Analysis  
 11: University Drive & Meridain Road

2035 AM  
 2/4/2013

												
Movement	EBL	EBT	EBR	WBL	WBT	WBR	NBL	NBT	NBR	SBL	SBT	SBR
Lane Configurations		 			 			 			 	
Volume (vph)	29	853	365	88	226	84	120	136	92	178	222	0
Ideal Flow (vphpl)	1900	1900	1900	1900	1900	1900	1900	1900	1900	1900	1900	1900
Total Lost time (s)	4.0	4.0		4.0	4.0		4.0	4.0		4.0	4.0	
Lane Util. Factor	1.00	0.95		1.00	0.95		1.00	0.95		1.00	0.95	
Flt	1.00	0.96		1.00	0.96		1.00	0.94		1.00	1.00	
Flt Protected	0.95	1.00		0.95	1.00		0.95	1.00		0.95	1.00	
Satd. Flow (prot)	1770	3380		1770	3396		1770	3325		1770	3539	
Flt Permitted	0.55	1.00		0.14	1.00		0.60	1.00		0.60	1.00	
Satd. Flow (perm)	1015	3380		252	3396		1115	3325		1108	3539	
Peak-hour factor, PHF	0.90	0.90	0.90	0.90	0.90	0.90	0.90	0.90	0.90	0.90	0.90	0.90
Adj. Flow (vph)	32	948	406	98	251	93	133	151	102	198	247	0
RTOR Reduction (vph)	0	79	0	0	37	0	0	75	0	0	0	0
Lane Group Flow (vph)	32	1275	0	98	307	0	133	178	0	198	247	0
Turn Type	Perm			Perm			Perm			Perm		Perm
Protected Phases		4			8			2			6	
Permitted Phases	4			8			2			6		6
Actuated Green, G (s)	36.0	36.0		36.0	36.0		16.0	16.0		16.0	16.0	
Effective Green, g (s)	36.0	36.0		36.0	36.0		16.0	16.0		16.0	16.0	
Actuated g/C Ratio	0.60	0.60		0.60	0.60		0.27	0.27		0.27	0.27	
Clearance Time (s)	4.0	4.0		4.0	4.0		4.0	4.0		4.0	4.0	
Lane Grp Cap (vph)	609	2028		151	2038		297	887		295	944	
v/s Ratio Prot		0.38			0.09			0.05			0.07	
v/s Ratio Perm	0.03			c0.39			0.12			c0.18		
v/c Ratio	0.05	0.63		0.65	0.15		0.45	0.20		0.67	0.26	
Uniform Delay, d1	5.0	7.7		7.9	5.3		18.3	17.0		19.7	17.3	
Progression Factor	1.00	1.00		1.00	1.00		1.00	1.00		1.00	1.00	
Incremental Delay, d2	0.2	1.5		19.6	0.2		4.8	0.5		11.6	0.7	
Delay (s)	5.1	9.2		27.5	5.4		23.1	17.6		31.2	18.0	
Level of Service	A	A		C	A		C	B		C	B	
Approach Delay (s)		9.1			10.3			19.5			23.9	
Approach LOS		A			B			B			C	
<b>Intersection Summary</b>												
HCM Average Control Delay			13.3			HCM Level of Service			B			
HCM Volume to Capacity ratio			0.65									
Actuated Cycle Length (s)			60.0			Sum of lost time (s)			8.0			
Intersection Capacity Utilization			70.0%			ICU Level of Service			C			
Analysis Period (min)			15									

c Critical Lane Group

HCM Signalized Intersection Capacity Analysis  
 17: Apache Trail & Meridain Road

2035 AM  
 2/4/2013





























Movement	EBL	EBT	EBR	WBL	WBT	WBR	NBL	NBT	NBR	SBL	SBT	SBR
Lane Configurations												
Volume (vph)	23	1177	230	339	1028	138	253	182	324	281	315	47
Ideal Flow (vphpl)	1900	1900	1900	1900	1900	1900	1900	1900	1900	1900	1900	1900
Total Lost time (s)	4.0	4.0	4.0	4.0	4.0	4.0	4.0	4.0		4.0	4.0	
Lane Util. Factor	1.00	0.91	1.00	0.97	0.91	1.00	1.00	0.95		1.00	0.95	
Frt	1.00	1.00	0.85	1.00	1.00	0.85	1.00	0.90		1.00	0.98	
Flt Protected	0.95	1.00	1.00	0.95	1.00	1.00	0.95	1.00		0.95	1.00	
Satd. Flow (prot)	1770	5085	1583	3433	5085	1583	1770	3199		1770	3471	
Flt Permitted	0.21	1.00	1.00	0.95	1.00	1.00	0.43	1.00		0.29	1.00	
Satd. Flow (perm)	392	5085	1583	3433	5085	1583	804	3199		538	3471	
Peak-hour factor, PHF	0.90	0.90	0.90	0.90	0.90	0.90	0.90	0.90	0.90	0.90	0.90	0.90
Adj. Flow (vph)	26	1308	256	377	1142	153	281	202	360	312	350	52
RTOR Reduction (vph)	0	0	187	0	0	103	0	133	0	0	16	0
Lane Group Flow (vph)	26	1308	69	377	1142	50	281	429	0	312	386	0
Turn Type	pm+pt		Perm	Prot		Perm	pm+pt			pm+pt		
Protected Phases	7	4		3	8		5	2		1	6	
Permitted Phases	4		4			8	2			6		
Actuated Green, G (s)	23.0	19.0	19.0	8.0	23.0	23.0	27.0	18.0		27.0	18.0	
Effective Green, g (s)	23.0	19.0	19.0	8.0	23.0	23.0	27.0	18.0		27.0	18.0	
Actuated g/C Ratio	0.33	0.27	0.27	0.11	0.33	0.33	0.39	0.26		0.39	0.26	
Clearance Time (s)	4.0	4.0	4.0	4.0	4.0	4.0	4.0	4.0		4.0	4.0	
Lane Grp Cap (vph)	208	1380	430	392	1671	520	434	823		366	893	
v/s Ratio Prot	0.01	c0.26		c0.11	c0.22		0.08	0.13		c0.11	0.11	
v/s Ratio Perm	0.03		0.04			0.03	0.17			c0.22		
v/c Ratio	0.12	0.95	0.16	0.96	0.68	0.10	0.65	0.52		0.85	0.43	
Uniform Delay, d1	16.3	25.0	19.4	30.8	20.3	16.3	15.8	22.3		16.6	21.7	
Progression Factor	1.00	1.00	1.00	1.00	1.00	1.00	1.00	1.00		1.00	1.00	
Incremental Delay, d2	1.2	14.6	0.8	36.8	2.3	0.4	7.3	2.4		21.5	1.5	
Delay (s)	17.5	39.6	20.2	67.6	22.6	16.7	23.1	24.7		38.1	23.3	
Level of Service	B	D	C	E	C	B	C	C		D	C	
Approach Delay (s)		36.1			32.2			24.1			29.7	
Approach LOS		D			C			C			C	

Intersection Summary		
HCM Average Control Delay	31.7	HCM Level of Service C
HCM Volume to Capacity ratio	0.95	
Actuated Cycle Length (s)	70.0	Sum of lost time (s) 20.0
Intersection Capacity Utilization	76.8%	ICU Level of Service D
Analysis Period (min)	15	

c Critical Lane Group

HCM Signalized Intersection Capacity Analysis  
 22: Broadway Avenue & Meridain Road

2035 AM  
 2/4/2013

												
Movement	EBL	EBT	EBR	WBL	WBT	WBR	NBL	NBT	NBR	SBL	SBT	SBR
Lane Configurations		 		 	 			 			 	
Volume (vph)	55	730	281	317	353	157	142	521	326	195	675	53
Ideal Flow (vphpl)	1900	1900	1900	1900	1900	1900	1900	1900	1900	1900	1900	1900
Total Lost time (s)	4.0	4.0	4.0	4.0	4.0		4.0	4.0	4.0	4.0	4.0	
Lane Util. Factor	1.00	0.95	1.00	0.97	0.95		1.00	0.95	1.00	1.00	0.95	
Frt	1.00	1.00	0.85	1.00	0.95		1.00	1.00	0.85	1.00	0.99	
Flt Protected	0.95	1.00	1.00	0.95	1.00		0.95	1.00	1.00	0.95	1.00	
Satd. Flow (prot)	1770	3539	1583	3433	3376		1770	3539	1583	1770	3500	
Flt Permitted	0.41	1.00	1.00	0.95	1.00		0.24	1.00	1.00	0.31	1.00	
Satd. Flow (perm)	761	3539	1583	3433	3376		438	3539	1583	582	3500	
Peak-hour factor, PHF	0.90	0.90	0.90	0.90	0.90	0.90	0.90	0.90	0.90	0.90	0.90	0.90
Adj. Flow (vph)	61	811	312	352	392	174	158	579	362	217	750	59
RTOR Reduction (vph)	0	0	145	0	84	0	0	0	161	0	9	0
Lane Group Flow (vph)	61	811	167	352	482	0	158	579	201	217	800	0
Turn Type	pm+pt		Perm	Prot			pm+pt		Perm	pm+pt		
Protected Phases	7	4		3	8		5	2		1	6	
Permitted Phases	4		4				2		2	6		
Actuated Green, G (s)	20.0	16.0	16.0	7.0	19.0		21.0	17.0	17.0	21.0	17.0	
Effective Green, g (s)	20.0	16.0	16.0	7.0	19.0		21.0	17.0	17.0	21.0	17.0	
Actuated g/C Ratio	0.33	0.27	0.27	0.12	0.32		0.35	0.28	0.28	0.35	0.28	
Clearance Time (s)	4.0	4.0	4.0	4.0	4.0		4.0	4.0	4.0	4.0	4.0	
Lane Grp Cap (vph)	321	944	422	401	1069		242	1003	449	283	992	
v/s Ratio Prot	0.01	c0.23		c0.10	c0.14		0.04	0.16		c0.05	c0.23	
v/s Ratio Perm	0.05		0.11				0.18		0.13	0.22		
v/c Ratio	0.19	0.86	0.40	0.88	0.45		0.65	0.58	0.45	0.77	0.81	
Uniform Delay, d1	13.8	20.9	18.0	26.1	16.3		14.8	18.4	17.7	16.0	20.0	
Progression Factor	1.00	1.00	1.00	1.00	1.00		1.00	1.00	1.00	1.00	1.00	
Incremental Delay, d2	1.3	10.0	2.8	22.8	1.4		12.9	2.4	3.2	17.9	7.0	
Delay (s)	15.1	31.0	20.8	48.9	17.7		27.7	20.8	20.9	33.9	27.0	
Level of Service	B	C	C	D	B		C	C	C	C	C	
Approach Delay (s)		27.5			29.7			21.8			28.4	
Approach LOS		C			C			C			C	

Intersection Summary		
HCM Average Control Delay	26.7	HCM Level of Service C
HCM Volume to Capacity ratio	0.89	
Actuated Cycle Length (s)	60.0	Sum of lost time (s) 20.0
Intersection Capacity Utilization	70.8%	ICU Level of Service C
Analysis Period (min)	15	





























c Critical Lane Group



# HCM Signalized Intersection Capacity Analysis

## 27: Southern Avenue & Meridain Road

2035 AM  
2/4/2013

													
Movement	EBL	EBT	EBR	WBL	WBT	WBR	NBL	NBT	NBR	SBL	SBT	SBR	
Lane Configurations		 			 		 	 			 		
Volume (vph)	105	137	24	0	702	441	378	689	507	94	801	175	
Ideal Flow (vphpl)	1900	1900	1900	1900	1900	1900	1900	1900	1900	1900	1900	1900	
Total Lost time (s)	4.0	4.0			4.0	4.0	4.0	4.0	4.0	4.0	4.0		
Lane Util. Factor	1.00	0.95			0.95	1.00	0.97	0.95	1.00	1.00	0.95		
Flt	1.00	0.98			1.00	0.85	1.00	1.00	0.85	1.00	0.97		
Flt Protected	0.95	1.00			1.00	1.00	0.95	1.00	1.00	0.95	1.00		
Satd. Flow (prot)	1770	3459			3539	1583	3433	3539	1583	1770	3444		
Flt Permitted	0.18	1.00			1.00	1.00	0.95	1.00	1.00	0.27	1.00		
Satd. Flow (perm)	339	3459			3539	1583	3433	3539	1583	507	3444		
Peak-hour factor, PHF	0.90	0.90	0.90	0.90	0.90	0.90	0.90	0.90	0.90	0.90	0.90	0.90	
Adj. Flow (vph)	117	152	27	0	780	490	420	766	563	104	890	194	
RTOR Reduction (vph)	0	18	0	0	0	59	0	0	340	0	25	0	
Lane Group Flow (vph)	117	161	0	0	780	431	420	766	223	104	1059	0	
Turn Type	pm+pt			Perm		pm+ov	Prot		Perm	pm+pt			
Protected Phases	7	4			8	1	5	2		1	6		
Permitted Phases	4			8		8			2	6			
Actuated Green, G (s)	25.2	25.2			18.0	26.1	10.4	29.7	29.7	35.5	27.4		
Effective Green, g (s)	25.2	25.2			18.0	26.1	10.4	29.7	29.7	35.5	27.4		
Actuated g/C Ratio	0.34	0.34			0.24	0.35	0.14	0.40	0.40	0.47	0.37		
Clearance Time (s)	4.0	4.0			4.0	4.0	4.0	4.0	4.0	4.0	4.0		
Vehicle Extension (s)	3.0	3.0			3.0	3.0	3.0	3.0	3.0	3.0	3.0		
Lane Grp Cap (vph)	175	1162			849	635	476	1401	627	376	1258		
v/s Ratio Prot	c0.03	0.05			c0.22	0.07	c0.12	0.22		0.03	c0.31		
v/s Ratio Perm	0.20					0.20			0.14	0.10			
v/c Ratio	0.67	0.14			0.92	0.68	0.88	0.55	0.36	0.28	0.84		
Uniform Delay, d1	20.9	17.3			27.8	20.9	31.7	17.5	15.9	11.4	21.8		
Progression Factor	1.00	1.00			1.00	1.00	1.00	1.00	1.00	1.00	1.00		
Incremental Delay, d2	9.3	0.1			14.6	2.9	17.3	1.5	1.6	0.4	6.9		
Delay (s)	30.2	17.4			42.4	23.8	49.0	19.0	17.5	11.8	28.8		
Level of Service	C	B			D	C	D	B	B	B	C		
Approach Delay (s)		22.5			35.2			25.7			27.3		
Approach LOS		C			D			C			C		
<b>Intersection Summary</b>													
HCM Average Control Delay			28.6									HCM Level of Service	C
HCM Volume to Capacity ratio			0.85										
Actuated Cycle Length (s)			75.0									Sum of lost time (s)	16.0
Intersection Capacity Utilization			77.1%									ICU Level of Service	D
Analysis Period (min)			15										
c Critical Lane Group													

# HCM Signalized Intersection Capacity Analysis

## 68: US 60 WB On-Ramp & Meridain Road

2035 AM  
2/4/2013



Movement	EBL	EBR	NBL	NBT	SBT	SBR
Lane Configurations			↔↔	↑↑	↑↑	↗
Volume (vph)	0	0	1084	381	338	255
Ideal Flow (vphpl)	1900	1900	1900	1900	1900	1900
Total Lost time (s)			4.0	4.0	4.0	4.0
Lane Util. Factor			0.97	0.95	0.95	1.00
Frt			1.00	1.00	1.00	0.85
Flt Protected			0.95	1.00	1.00	1.00
Satd. Flow (prot)			3433	3539	3539	1583
Flt Permitted			0.18	1.00	1.00	1.00
Satd. Flow (perm)			666	3539	3539	1583
Peak-hour factor, PHF	0.90	0.90	0.90	0.90	0.90	0.90
Adj. Flow (vph)	0	0	1204	423	376	283
RTOR Reduction (vph)	0	0	0	0	0	192
Lane Group Flow (vph)	0	0	1204	423	376	91
Turn Type			pm+pt			Perm
Protected Phases			2	5 6	6	
Permitted Phases			5 6			6
Actuated Green, G (s)			61.0	65.0	16.0	16.0
Effective Green, g (s)			61.0	65.0	16.0	16.0
Actuated g/C Ratio			0.94	1.00	0.25	0.25
Clearance Time (s)			4.0		4.0	4.0
Lane Grp Cap (vph)			1519	3539	871	390
v/s Ratio Prot			c0.26	0.12	0.11	
v/s Ratio Perm			c0.49			0.06
v/c Ratio			0.79	0.12	0.43	0.23
Uniform Delay, d1			13.1	0.0	20.7	19.6
Progression Factor			0.66	1.00	1.00	1.00
Incremental Delay, d2			1.4	0.0	1.6	1.4
Delay (s)			10.1	0.0	22.2	21.0
Level of Service			B	A	C	C
Approach Delay (s)	0.0			7.5	21.7	
Approach LOS	A			A	C	

### Intersection Summary

HCM Average Control Delay	11.6	HCM Level of Service	B
HCM Volume to Capacity ratio	0.78		
Actuated Cycle Length (s)	65.0	Sum of lost time (s)	4.0
Intersection Capacity Utilization	53.4%	ICU Level of Service	A
Analysis Period (min)	15		

c Critical Lane Group

# HCM Signalized Intersection Capacity Analysis

## 71: US 60 EB Off-Ramp & Meridain Road

2035 AM  
2/4/2013

































Movement	EBL	EBR	NBL	NBT	SBT	SBR
Lane Configurations	↶	↷		↷	↷	
Volume (vph)	67	352	0	1465	338	0
Ideal Flow (vphpl)	1900	1900	1900	1900	1900	1900
Grade (%)	1%			0%	0%	
Total Lost time (s)	4.0	4.0		4.0	4.0	
Lane Util. Factor	1.00	0.88		0.91	0.95	
Frt	1.00	0.85		1.00	1.00	
Flt Protected	0.95	1.00		1.00	1.00	
Satd. Flow (prot)	1761	2773		5085	3539	
Flt Permitted	0.95	1.00		1.00	1.00	
Satd. Flow (perm)	1761	2773		5085	3539	
Peak-hour factor, PHF	0.90	0.90	0.90	0.90	0.90	0.90
Adj. Flow (vph)	74	391	0	1628	376	0
RTOR Reduction (vph)	0	174	0	0	0	0
Lane Group Flow (vph)	74	217	0	1628	376	0
Turn Type	Perm					
Protected Phases	4 12			2	2	
Permitted Phases		4 12				
Actuated Green, G (s)	36.0	36.0		21.0	21.0	
Effective Green, g (s)	36.0	36.0		21.0	21.0	
Actuated g/C Ratio	0.55	0.55		0.32	0.32	
Clearance Time (s)				4.0	4.0	
Lane Grp Cap (vph)	975	1536		1643	1143	
v/s Ratio Prot	0.04			0.32	0.11	
v/s Ratio Perm		0.08				
v/c Ratio	0.08	0.14		0.99	0.33	
Uniform Delay, d1	6.8	7.0		21.9	16.7	
Progression Factor	1.00	1.00		1.08	0.87	
Incremental Delay, d2	0.2	0.2		19.5	0.7	
Delay (s)	6.9	7.2		43.2	15.3	
Level of Service	A	A		D	B	
Approach Delay (s)	7.2			43.2	15.3	
Approach LOS	A			D	B	

### Intersection Summary

HCM Average Control Delay	32.1	HCM Level of Service	C
HCM Volume to Capacity ratio	0.45		
Actuated Cycle Length (s)	65.0	Sum of lost time (s)	8.0
Intersection Capacity Utilization	53.4%	ICU Level of Service	A
Analysis Period (min)	15		
c Critical Lane Group			

HCM Signalized Intersection Capacity Analysis  
 31: Baseline Road & Meridain Road

























2035 AM  
 2/4/2013

													
Movement	EBL	EBT	EBR	WBL	WBT	WBR	NBL	NBT	NBR	SBL	SBT	SBR	
Lane Configurations		  			 	 		  		 	 		
Volume (vph)	22	371	51	147	1095	322	295	766	33	50	208	77	
Ideal Flow (vphpl)	1900	1900	1900	1900	1900	1900	1900	1900	1900	1900	1900	1900	
Total Lost time (s)	4.0	4.0		4.0	4.0	4.0	4.0	4.0		4.0	4.0	4.0	
Lane Util. Factor	1.00	0.91		1.00	0.95	0.88	1.00	0.91		0.97	0.95	1.00	
Frt	1.00	0.98		1.00	1.00	0.85	1.00	0.99		1.00	1.00	0.85	
Flt Protected	0.95	1.00		0.95	1.00	1.00	0.95	1.00		0.95	1.00	1.00	
Satd. Flow (prot)	1770	4993		1770	3539	2787	1770	5054		3433	3539	1583	
Flt Permitted	0.17	1.00		0.41	1.00	1.00	0.54	1.00		0.95	1.00	1.00	
Satd. Flow (perm)	317	4993		764	3539	2787	998	5054		3433	3539	1583	
Peak-hour factor, PHF	0.90	0.90	0.90	0.90	0.90	0.90	0.90	0.90	0.90	0.90	0.90	0.90	
Adj. Flow (vph)	24	412	57	163	1217	358	328	851	37	56	231	86	
RTOR Reduction (vph)	0	26	0	0	0	164	0	8	0	0	0	67	
Lane Group Flow (vph)	24	443	0	163	1217	194	328	880	0	56	231	19	
Turn Type	pm+pt			pm+pt		pm+ov	pm+pt			Prot		Perm	
Protected Phases	7	4		3	8	1	5	2		1	6		
Permitted Phases	4			8		8	2					6	
Actuated Green, G (s)	25.1	23.5		31.5	26.7	31.4	22.6	16.0		4.7	14.1	14.1	
Effective Green, g (s)	25.1	23.5		31.5	26.7	31.4	22.6	16.0		4.7	14.1	14.1	
Actuated g/C Ratio	0.39	0.36		0.48	0.41	0.48	0.35	0.25		0.07	0.22	0.22	
Clearance Time (s)	4.0	4.0		4.0	4.0	4.0	4.0	4.0		4.0	4.0	4.0	
Vehicle Extension (s)	3.0	3.0		3.0	3.0	3.0	3.0	3.0		3.0	3.0	3.0	
Lane Grp Cap (vph)	158	1805		445	1454	1518	425	1244		248	768	343	
v/s Ratio Prot	0.00	0.09		c0.03	c0.34	0.01	c0.08	0.17		0.02	0.07		
v/s Ratio Perm	0.05			0.15		0.06	c0.19					0.01	
v/c Ratio	0.15	0.25		0.37	0.84	0.13	0.77	0.71		0.23	0.30	0.05	
Uniform Delay, d1	14.0	14.5		9.6	17.2	9.3	17.8	22.4		28.4	21.3	20.2	
Progression Factor	1.00	1.00		1.00	1.00	1.00	1.00	1.00		1.06	1.60	2.98	
Incremental Delay, d2	0.4	0.1		0.5	4.4	0.0	8.4	3.4		0.5	1.0	0.3	
Delay (s)	14.4	14.6		10.1	21.6	9.3	26.3	25.8		30.6	35.1	60.4	
Level of Service	B	B		B	C	A	C	C		C	D	E	
Approach Delay (s)		14.6			18.0			25.9			40.3		
Approach LOS		B			B			C			D		
<b>Intersection Summary</b>													
HCM Average Control Delay			22.2		HCM Level of Service						C		
HCM Volume to Capacity ratio			0.84										
Actuated Cycle Length (s)			65.0		Sum of lost time (s)						16.0		
Intersection Capacity Utilization			69.0%		ICU Level of Service						C		
Analysis Period (min)			15										
c Critical Lane Group													

# HCM Signalized Intersection Capacity Analysis

## 2: Guadalupe Road & Meridian Road

2035 AM  
2/4/2013



























												
Movement	EBL	EBT	EBR	WBL	WBT	WBR	NBL	NBT	NBR	SBL	SBT	SBR
Lane Configurations		 			 			 			 	
Volume (vph)	184	206	69	47	324	127	163	793	61	32	466	141
Ideal Flow (vphpl)	1900	1900	1900	1900	1900	1900	1900	1900	1900	1900	1900	1900
Total Lost time (s)	4.0	4.0		4.0	4.0		4.0	4.0		4.0	4.0	
Lane Util. Factor	1.00	0.95		1.00	0.95		1.00	0.95		1.00	0.95	
Frt	1.00	0.96		1.00	0.96		1.00	0.99		1.00	0.97	
Flt Protected	0.95	1.00		0.95	1.00		0.95	1.00		0.95	1.00	
Satd. Flow (prot)	1770	3406		1770	3390		1770	3501		1770	3416	
Flt Permitted	0.45	1.00		0.57	1.00		0.35	1.00		0.22	1.00	
Satd. Flow (perm)	831	3406		1053	3390		657	3501		404	3416	
Peak-hour factor, PHF	0.90	0.90	0.90	0.90	0.90	0.90	0.90	0.90	0.90	0.90	0.90	0.90
Adj. Flow (vph)	204	229	77	52	360	141	181	881	68	36	518	157
RTOR Reduction (vph)	0	48	0	0	49	0	0	13	0	0	63	0
Lane Group Flow (vph)	204	258	0	52	452	0	181	936	0	36	612	0
Turn Type	Perm			Perm			Perm			Perm		
Protected Phases		4			8			2			6	
Permitted Phases	4			8			2			6		
Actuated Green, G (s)	17.0	17.0		17.0	17.0		20.0	20.0		20.0	20.0	
Effective Green, g (s)	17.0	17.0		17.0	17.0		20.0	20.0		20.0	20.0	
Actuated g/C Ratio	0.38	0.38		0.38	0.38		0.44	0.44		0.44	0.44	
Clearance Time (s)	4.0	4.0		4.0	4.0		4.0	4.0		4.0	4.0	
Lane Grp Cap (vph)	314	1287		398	1281		292	1556		180	1518	
v/s Ratio Prot		0.08			0.13			0.27			0.18	
v/s Ratio Perm	c0.25			0.05			c0.28			0.09		
v/c Ratio	0.65	0.20		0.13	0.35		0.62	0.60		0.20	0.40	
Uniform Delay, d1	11.5	9.4		9.2	10.1		9.6	9.5		7.6	8.5	
Progression Factor	1.00	1.00		1.00	1.00		1.00	1.00		1.00	1.00	
Incremental Delay, d2	10.0	0.4		0.7	0.8		9.5	1.7		2.5	0.8	
Delay (s)	21.5	9.8		9.8	10.8		19.1	11.2		10.1	9.3	
Level of Service	C	A		A	B		B	B		B	A	
Approach Delay (s)		14.5			10.7			12.5			9.3	
Approach LOS		B			B			B			A	
<b>Intersection Summary</b>												
HCM Average Control Delay			11.7			HCM Level of Service			B			
HCM Volume to Capacity ratio			0.63									
Actuated Cycle Length (s)			45.0			Sum of lost time (s)			8.0			
Intersection Capacity Utilization			63.7%			ICU Level of Service			B			
Analysis Period (min)			15									
c Critical Lane Group												



# HCM Signalized Intersection Capacity Analysis

## 35: Elliot Road & Meridian Road

2035 AM  
2/4/2013

												
Movement	EBL	EBT	EBR	WBL	WBT	WBR	NBL	NBT	NBR	SBL	SBT	SBR
Lane Configurations		  			  		 	 			 	
Volume (vph)	116	931	116	261	1304	174	186	495	93	77	447	115
Ideal Flow (vphpl)	1900	1900	1900	1900	1900	1900	1900	1900	1900	1900	1900	1900
Total Lost time (s)	4.0	4.0		4.0	4.0		4.0	4.0		4.0	4.0	
Lane Util. Factor	1.00	0.91		1.00	0.91		0.97	0.95		1.00	0.95	
Fr <sub>t</sub>	1.00	0.98		1.00	0.98		1.00	0.98		1.00	0.97	
Fl <sub>t</sub> Protected	0.95	1.00		0.95	1.00		0.95	1.00		0.95	1.00	
Satd. Flow (prot)	1770	5001		1770	4996		3433	3455		1770	3430	
Fl <sub>t</sub> Permitted	0.24	1.00		0.19	1.00		0.95	1.00		0.27	1.00	
Satd. Flow (perm)	444	5001		358	4996		3433	3455		502	3430	
Peak-hour factor, PHF	0.90	0.90	0.90	0.90	0.90	0.90	0.90	0.90	0.90	0.90	0.90	0.90
Adj. Flow (vph)	129	1034	129	290	1449	193	207	550	103	86	497	128
RTOR Reduction (vph)	0	26	0	0	28	0	0	25	0	0	38	0
Lane Group Flow (vph)	129	1137	0	290	1614	0	207	628	0	86	587	0
Turn Type	pm+pt			pm+pt			Prot			pm+pt		
Protected Phases	7	4		3	8		5	2		1	6	
Permitted Phases	4			8						6		
Actuated Green, G (s)	20.0	16.8		28.8	21.6		4.0	17.6		20.0	16.8	
Effective Green, g (s)	20.0	16.8		28.8	21.6		4.0	17.6		20.0	16.8	
Actuated g/C Ratio	0.32	0.27		0.47	0.35		0.06	0.29		0.32	0.27	
Clearance Time (s)	4.0	4.0		4.0	4.0		4.0	4.0		4.0	4.0	
Vehicle Extension (s)	3.0	3.0		3.0	3.0		3.0	3.0		3.0	3.0	
Lane Grp Cap (vph)	213	1364		351	1752		223	987		229	935	
v/s Ratio Prot	0.03	0.23		c0.11	c0.32		c0.06	c0.18		0.02	0.17	
v/s Ratio Perm	0.17			0.28						0.10		
v/c Ratio	0.61	0.83		0.83	0.92		0.93	0.64		0.38	0.63	
Uniform Delay, d <sub>1</sub>	16.5	21.1		12.6	19.2		28.7	19.2		15.1	19.7	
Progression Factor	1.00	1.00		1.00	1.00		1.00	1.00		1.00	1.00	
Incremental Delay, d <sub>2</sub>	4.8	4.5		14.6	8.5		40.4	3.1		1.0	3.2	
Delay (s)	21.3	25.6		27.2	27.6		69.1	22.3		16.1	22.8	
Level of Service	C	C		C	C		E	C		B	C	
Approach Delay (s)		25.2			27.6			33.6			22.0	
Approach LOS		C			C			C			C	
<b>Intersection Summary</b>												
HCM Average Control Delay			27.2			HCM Level of Service				C		
HCM Volume to Capacity ratio			0.74									
Actuated Cycle Length (s)			61.6			Sum of lost time (s)			8.0			
Intersection Capacity Utilization			70.2%			ICU Level of Service				C		
Analysis Period (min)			15									
c Critical Lane Group												

HCM Signalized Intersection Capacity Analysis  
 37: Warner Road & Meridian Road























2035 AM  
 2/4/2013

Movement	EBL	EBT	EBR	WBL	WBT	WBR	NBL	NBT	NBR	SBL	SBT	SBR
Lane Configurations												
Volume (vph)	205	978	121	200	1156	151	63	396	69	130	652	87
Ideal Flow (vphpl)	1900	1900	1900	1900	1900	1900	1900	1900	1900	1900	1900	1900
Total Lost time (s)	4.0	4.0	4.0	4.0	4.0		4.0	4.0		4.0	4.0	
Lane Util. Factor	0.97	0.91	1.00	1.00	0.91		1.00	0.95		1.00	0.95	
Frt	1.00	1.00	0.85	1.00	0.98		1.00	0.98		1.00	0.98	
Flt Protected	0.95	1.00	1.00	0.95	1.00		0.95	1.00		0.95	1.00	
Satd. Flow (prot)	3433	5085	1583	1770	4997		1770	3460		1770	3476	
Flt Permitted	0.95	1.00	1.00	0.22	1.00		0.22	1.00		0.35	1.00	
Satd. Flow (perm)	3433	5085	1583	414	4997		419	3460		659	3476	
Peak-hour factor, PHF	0.90	0.90	0.90	0.90	0.90	0.90	0.90	0.90	0.90	0.90	0.90	0.90
Adj. Flow (vph)	228	1087	134	222	1284	168	70	440	77	144	724	97
RTOR Reduction (vph)	0	0	96	0	28	0	0	23	0	0	17	0
Lane Group Flow (vph)	228	1087	38	222	1424	0	70	494	0	144	804	0
Turn Type	Prot		Perm	pm+pt			pm+pt			pm+pt		
Protected Phases	7	4		3	8		5	2		1	6	
Permitted Phases			4	8			2			6		
Actuated Green, G (s)	5.0	17.0	17.0	24.0	18.0		20.2	17.8		21.8	18.6	
Effective Green, g (s)	5.0	17.0	17.0	24.0	18.0		20.2	17.8		21.8	18.6	
Actuated g/C Ratio	0.08	0.28	0.28	0.40	0.30		0.34	0.30		0.36	0.31	
Clearance Time (s)	4.0	4.0	4.0	4.0	4.0		4.0	4.0		4.0	4.0	
Vehicle Extension (s)	3.0	3.0	3.0	3.0	3.0		3.0	3.0		3.0	3.0	
Lane Grp Cap (vph)	286	1441	449	301	1499		195	1026		299	1078	
v/s Ratio Prot	0.07	0.21		c0.07	c0.28		0.01	0.14		c0.03	c0.23	
v/s Ratio Perm			0.02	0.22			0.11			0.15		
v/c Ratio	0.80	0.75	0.08	0.74	0.95		0.36	0.48		0.48	0.75	
Uniform Delay, d1	27.0	19.6	15.8	13.3	20.6		14.4	17.3		13.6	18.6	
Progression Factor	1.00	1.00	1.00	1.00	1.00		1.00	1.00		1.00	1.00	
Incremental Delay, d2	14.3	2.3	0.1	9.1	13.0		1.1	1.6		1.2	4.7	
Delay (s)	41.3	21.9	15.9	22.4	33.6		15.5	18.9		14.8	23.3	
Level of Service	D	C	B	C	C		B	B		B	C	
Approach Delay (s)		24.4			32.1			18.5			22.0	
Approach LOS		C			C			B			C	
<b>Intersection Summary</b>												
HCM Average Control Delay			25.9	HCM Level of Service				C				
HCM Volume to Capacity ratio			0.71									
Actuated Cycle Length (s)			60.0	Sum of lost time (s)				8.0				
Intersection Capacity Utilization			69.2%	ICU Level of Service				C				
Analysis Period (min)			15									
c Critical Lane Group												

# HCM Signalized Intersection Capacity Analysis

## 41: Ray Road & Meridian Road































2035 AM  
2/4/2013

												
Movement	EBL	EBT	EBR	WBL	WBT	WBR	NBL	NBT	NBR	SBL	SBT	SBR
Lane Configurations												
Volume (vph)	106	532	71	22	1109	148	127	529	49	99	543	63
Ideal Flow (vphpl)	1900	1900	1900	1900	1900	1900	1900	1900	1900	1900	1900	1900
Total Lost time (s)	4.0	4.0		4.0	4.0	4.0	4.0	4.0		4.0	4.0	
Lane Util. Factor	0.97	0.91		0.97	0.91	1.00	1.00	0.95		1.00	0.95	
Flt	1.00	0.98		1.00	1.00	0.85	1.00	0.99		1.00	0.98	
Flt Protected	0.95	1.00		0.95	1.00	1.00	0.95	1.00		0.95	1.00	
Satd. Flow (prot)	3433	4995		3433	5085	1583	1770	3495		1770	3484	
Flt Permitted	0.95	1.00		0.95	1.00	1.00	0.22	1.00		0.41	1.00	
Satd. Flow (perm)	3433	4995		3433	5085	1583	406	3495		760	3484	
Peak-hour factor, PHF	0.90	0.90	0.90	0.90	0.90	0.90	0.90	0.90	0.90	0.90	0.90	0.90
Adj. Flow (vph)	118	591	79	24	1232	164	141	588	54	110	603	70
RTOR Reduction (vph)	0	26	0	0	0	112	0	12	0	0	15	0
Lane Group Flow (vph)	118	644	0	24	1232	52	141	630	0	110	658	0
Turn Type	Prot			Prot		Perm	pm+pt			Perm		
Protected Phases	7	4		3	8		5	2				6
Permitted Phases						8	2			6		
Actuated Green, G (s)	3.2	20.6		1.6	19.0	19.0	25.8	25.8		18.6	18.6	
Effective Green, g (s)	3.2	20.6		1.6	19.0	19.0	25.8	25.8		18.6	18.6	
Actuated g/C Ratio	0.05	0.34		0.03	0.32	0.32	0.43	0.43		0.31	0.31	
Clearance Time (s)	4.0	4.0		4.0	4.0	4.0	4.0	4.0		4.0	4.0	
Vehicle Extension (s)	3.0	3.0		3.0	3.0	3.0	3.0	3.0		3.0	3.0	
Lane Grp Cap (vph)	183	1715		92	1610	501	247	1503		236	1080	
v/s Ratio Prot	c0.03	0.13		0.01	c0.24		c0.03	0.18			0.19	
v/s Ratio Perm						0.03	c0.21			0.14		
v/c Ratio	0.64	0.38		0.26	0.77	0.10	0.57	0.42		0.47	0.61	
Uniform Delay, d1	27.8	14.9		28.6	18.5	14.5	11.7	11.9		16.7	17.6	
Progression Factor	1.00	1.00		1.00	1.00	1.00	0.79	0.77		1.00	1.00	
Incremental Delay, d2	7.6	0.1		1.5	2.2	0.1	3.0	0.8		6.5	2.6	
Delay (s)	35.4	15.0		30.1	20.7	14.6	12.1	9.9		23.2	20.2	
Level of Service	D	B		C	C	B	B	A		C	C	
Approach Delay (s)		18.0			20.2			10.3			20.6	
Approach LOS		B			C			B			C	
<b>Intersection Summary</b>												
HCM Average Control Delay			17.8			HCM Level of Service				B		
HCM Volume to Capacity ratio			0.64									
Actuated Cycle Length (s)			60.0			Sum of lost time (s)			12.0			
Intersection Capacity Utilization			62.1%			ICU Level of Service			B			
Analysis Period (min)			15									
c Critical Lane Group												

# HCM Signalized Intersection Capacity Analysis













## 58: Williams Field Road & Meridian Road

2035 AM  
2/4/2013

												
Movement	EBL	EBT	EBR	WBL	WBT	WBR	NBL	NBT	NBR	SBL	SBT	SBR
Lane Configurations	 	  		 	  			 			 	 
Volume (vph)	166	839	99	153	766	102	20	295	79	75	603	75
Ideal Flow (vphpl)	1900	1900	1900	1900	1900	1900	1900	1900	1900	1900	1900	1900
Total Lost time (s)	4.0	4.0		4.0	4.0		4.0	4.0		4.0	4.0	
Lane Util. Factor	0.97	0.91		0.97	0.91		1.00	0.95		1.00	0.95	
Flt	1.00	0.98		1.00	0.98		1.00	0.97		1.00	0.98	
Flt Protected	0.95	1.00		0.95	1.00		0.95	1.00		0.95	1.00	
Satd. Flow (prot)	3433	5005		3433	4996		1770	3427		1770	3481	
Flt Permitted	0.95	1.00		0.95	1.00		0.29	1.00		0.39	1.00	
Satd. Flow (perm)	3433	5005		3433	4996		534	3427		718	3481	
Peak-hour factor, PHF	0.90	0.90	0.90	0.90	0.90	0.90	0.90	0.90	0.90	0.90	0.90	0.90
Adj. Flow (vph)	184	932	110	170	851	113	22	328	88	83	670	83
RTOR Reduction (vph)	0	24	0	0	28	0	0	39	0	0	15	0
Lane Group Flow (vph)	184	1018	0	170	936	0	22	377	0	83	738	0
Turn Type	Prot			Prot			pm+pt			pm+pt		
Protected Phases	7	4		3	8		5	2		1	6	
Permitted Phases							2			6		
Actuated Green, G (s)	6.0	18.3		4.0	16.3		18.5	17.7		24.9	20.9	
Effective Green, g (s)	6.0	18.3		4.0	16.3		18.5	17.7		24.9	20.9	
Actuated g/C Ratio	0.10	0.31		0.07	0.27		0.31	0.29		0.41	0.35	
Clearance Time (s)	4.0	4.0		4.0	4.0		4.0	4.0		4.0	4.0	
Vehicle Extension (s)	3.0	3.0		3.0	3.0		3.0	3.0		3.0	3.0	
Lane Grp Cap (vph)	343	1527		229	1357		181	1011		368	1213	
v/s Ratio Prot	0.05	c0.20		c0.05	0.19		0.00	0.11		c0.02	c0.21	
v/s Ratio Perm							0.04			0.08		
v/c Ratio	0.54	0.67		0.74	0.69		0.12	0.37		0.23	0.61	
Uniform Delay, d1	25.7	18.2		27.5	19.6		14.7	16.8		11.0	16.2	
Progression Factor	1.00	1.00		1.00	1.00		1.91	1.90		0.51	0.45	
Incremental Delay, d2	1.6	1.1		12.2	1.5		0.3	1.0		0.3	2.1	
Delay (s)	27.3	19.3		39.7	21.1		28.3	33.0		5.9	9.4	
Level of Service	C	B		D	C		C	C		A	A	
Approach Delay (s)		20.5			23.9			32.7			9.0	
Approach LOS		C			C			C			A	
<b>Intersection Summary</b>												
HCM Average Control Delay			20.4			HCM Level of Service				C		
HCM Volume to Capacity ratio			0.59									
Actuated Cycle Length (s)			60.0			Sum of lost time (s)			12.0			
Intersection Capacity Utilization			58.5%			ICU Level of Service				B		
Analysis Period (min)			15									
c Critical Lane Group												

HCM Signalized Intersection Capacity Analysis  
62: SR 24 WB on-ramp & Meridian Road











2035 AM  
2/4/2013

						
Movement	EBL	EBR	NBL	NBT	SBT	SBR
Lane Configurations			 	 	 	
Volume (vph)	0	0	671	466	351	506
Ideal Flow (vphpl)	1900	1900	1900	1900	1900	1900
Total Lost time (s)			4.0	4.0	4.0	4.0
Lane Util. Factor			0.97	0.95	0.95	1.00
Frt			1.00	1.00	1.00	0.85
Flt Protected			0.95	1.00	1.00	1.00
Satd. Flow (prot)			3433	3539	3539	1583
Flt Permitted			0.19	1.00	1.00	1.00
Satd. Flow (perm)			675	3539	3539	1583
Peak-hour factor, PHF	0.90	0.90	0.90	0.90	0.90	0.90
Adj. Flow (vph)	0	0	746	518	390	562
RTOR Reduction (vph)	0	0	0	0	0	283
Lane Group Flow (vph)	0	0	746	518	390	279
Turn Type			pm+pt			Perm
Protected Phases			2	5 6	6	
Permitted Phases			5 6			6
Actuated Green, G (s)			56.0	60.0	16.0	16.0
Effective Green, g (s)			56.0	60.0	16.0	16.0
Actuated g/C Ratio			0.93	1.00	0.27	0.27
Clearance Time (s)			4.0		4.0	4.0
Lane Grp Cap (vph)			1365	3539	944	422
v/s Ratio Prot			c0.15	0.15	0.11	
v/s Ratio Perm			c0.36			c0.18
v/c Ratio			0.55	0.15	0.41	0.66
Uniform Delay, d1			9.5	0.0	18.1	19.6
Progression Factor			1.24	1.00	0.81	0.89
Incremental Delay, d2			0.9	0.0	1.1	6.7
Delay (s)			12.7	0.0	15.7	24.1
Level of Service			B	A	B	C
Approach Delay (s)	0.0			7.5	20.7	
Approach LOS	A			A	C	
<b>Intersection Summary</b>						
HCM Average Control Delay			13.2	HCM Level of Service		B
HCM Volume to Capacity ratio			0.58			
Actuated Cycle Length (s)			60.0	Sum of lost time (s)		8.0
Intersection Capacity Utilization			57.1%	ICU Level of Service		B
Analysis Period (min)			15			
c Critical Lane Group						



HCM Signalized Intersection Capacity Analysis  
63: SR 24 EB off-ramp & Meridian Road



























2035 AM  
2/4/2013

						
Movement	EBL	EBR	NBL	NBT	SBT	SBR
Lane Configurations						
Volume (vph)	254	559	0	1137	351	0
Ideal Flow (vphpl)	1900	1900	1900	1900	1900	1900
Total Lost time (s)	4.0	4.0		4.0	4.0	
Lane Util. Factor	1.00	0.88		0.91	0.95	
Flt	1.00	0.85		1.00	1.00	
Flt Protected	0.95	1.00		1.00	1.00	
Satd. Flow (prot)	1770	2787		5085	3539	
Flt Permitted	0.95	1.00		1.00	1.00	
Satd. Flow (perm)	1770	2787		5085	3539	
Peak-hour factor, PHF	0.90	0.90	0.90	0.90	0.90	0.90
Adj. Flow (vph)	282	621	0	1263	390	0
RTOR Reduction (vph)	0	112	0	0	0	0
Lane Group Flow (vph)	282	509	0	1263	390	0
Turn Type	Perm					
Protected Phases	4 12			2	2	
Permitted Phases		4 12				
Actuated Green, G (s)	36.0	36.0		16.0	16.0	
Effective Green, g (s)	36.0	36.0		16.0	16.0	
Actuated g/C Ratio	0.60	0.60		0.27	0.27	
Clearance Time (s)				4.0	4.0	
Lane Grp Cap (vph)	1062	1672		1356	944	
v/s Ratio Prot	0.16			c0.25	0.11	
v/s Ratio Perm		c0.18				
v/c Ratio	0.27	0.30		0.93	0.41	
Uniform Delay, d1	5.7	5.9		21.5	18.1	
Progression Factor	1.00	1.00		0.81	0.71	
Incremental Delay, d2	0.6	0.5		5.2	1.2	
Delay (s)	6.3	6.3		22.5	14.1	
Level of Service	A	A		C	B	
Approach Delay (s)	6.3			22.5	14.1	
Approach LOS	A			C	B	
<b>Intersection Summary</b>						
HCM Average Control Delay			15.5	HCM Level of Service		B
HCM Volume to Capacity ratio			0.50			
Actuated Cycle Length (s)			60.0	Sum of lost time (s)		8.0
Intersection Capacity Utilization			57.1%	ICU Level of Service		B
Analysis Period (min)			15			
c Critical Lane Group						

# HCM Signalized Intersection Capacity Analysis

## 60: Pecos Road & Meridian Road

2035 AM  
2/4/2013

												
Movement	EBL	EBT	EBR	WBL	WBT	WBR	NBL	NBT	NBR	SBL	SBT	SBR
Lane Configurations		 			 			 		 	 	 
Volume (vph)	3	27	9	78	583	50	143	1058	229	315	904	51
Ideal Flow (vphpl)	1900	1900	1900	1900	1900	1900	1900	1900	1900	1900	1900	1900
Total Lost time (s)	4.0	4.0		4.0	4.0		4.0	4.0		4.0	4.0	
Lane Util. Factor	1.00	0.95		1.00	0.95		1.00	0.95		0.97	0.95	
Frt	1.00	0.96		1.00	0.99		1.00	0.97		1.00	0.99	
Flt Protected	0.95	1.00		0.95	1.00		0.95	1.00		0.95	1.00	
Satd. Flow (prot)	1770	3406		1770	3497		1770	3445		3433	3511	
Flt Permitted	0.25	1.00		0.73	1.00		0.16	1.00		0.95	1.00	
Satd. Flow (perm)	466	3406		1359	3497		298	3445		3433	3511	
Peak-hour factor, PHF	0.90	0.90	0.90	0.90	0.90	0.90	0.90	0.90	0.90	0.90	0.90	0.90
Adj. Flow (vph)	3	30	10	87	648	56	159	1176	254	350	1004	57
RTOR Reduction (vph)	0	7	0	0	11	0	0	30	0	0	7	0
Lane Group Flow (vph)	3	33	0	87	693	0	159	1400	0	350	1054	0
Turn Type	Perm			Perm			pm+pt			Prot		
Protected Phases		4			8		5	2		1	6	
Permitted Phases	4			8			2					
Actuated Green, G (s)	16.0	16.0		16.0	16.0		31.0	25.0		7.0	26.0	
Effective Green, g (s)	16.0	16.0		16.0	16.0		31.0	25.0		7.0	26.0	
Actuated g/C Ratio	0.27	0.27		0.27	0.27		0.52	0.42		0.12	0.43	
Clearance Time (s)	4.0	4.0		4.0	4.0		4.0	4.0		4.0	4.0	
Lane Grp Cap (vph)	124	908		362	933		301	1435		401	1521	
v/s Ratio Prot		0.01			c0.20		0.05	c0.41		c0.10	0.30	
v/s Ratio Perm	0.01			0.06			0.22					
v/c Ratio	0.02	0.04		0.24	0.74		0.53	0.98		0.87	0.69	
Uniform Delay, d1	16.2	16.3		17.2	20.1		9.0	17.2		26.1	13.8	
Progression Factor	1.00	1.00		1.00	1.00		0.99	1.02		0.99	0.81	
Incremental Delay, d2	0.4	0.1		1.6	5.3		6.2	18.0		21.8	2.6	
Delay (s)	16.6	16.4		18.8	25.4		15.1	35.5		47.6	13.7	
Level of Service	B	B		B	C		B	D		D	B	
Approach Delay (s)		16.4			24.7			33.5			22.1	
Approach LOS		B			C			C			C	



























### Intersection Summary

HCM Average Control Delay	27.3	HCM Level of Service	C
HCM Volume to Capacity ratio	0.88		
Actuated Cycle Length (s)	60.0	Sum of lost time (s)	12.0
Intersection Capacity Utilization	73.2%	ICU Level of Service	D
Analysis Period (min)	15		

c Critical Lane Group

HCM Signalized Intersection Capacity Analysis  
50: Germann Road & Meridian Road

























2035 AM  
2/4/2013

												
Movement	EBL	EBT	EBR	WBL	WBT	WBR	NBL	NBT	NBR	SBL	SBT	SBR
Lane Configurations		 		 	 			 			 	
Volume (vph)	127	723	54	337	1065	286	25	330	152	110	239	18
Ideal Flow (vphpl)	1900	1900	1900	1900	1900	1900	1900	1900	1900	1900	1900	1900
Total Lost time (s)	4.0	4.0		4.0	4.0		4.0	4.0		4.0	4.0	
Lane Util. Factor	1.00	0.95		0.97	0.95		1.00	0.95		1.00	0.95	
Fr <sub>t</sub>	1.00	0.99		1.00	0.97		1.00	0.95		1.00	0.99	
Fl <sub>t</sub> Protected	0.95	1.00		0.95	1.00		0.95	1.00		0.95	1.00	
Satd. Flow (prot)	1770	3502		3433	3427		1770	3372		1770	3502	
Fl <sub>t</sub> Permitted	0.20	1.00		0.95	1.00		0.58	1.00		0.35	1.00	
Satd. Flow (perm)	373	3502		3433	3427		1074	3372		645	3502	
Peak-hour factor, PHF	0.90	0.90	0.90	0.90	0.90	0.90	0.90	0.90	0.90	0.90	0.90	0.90
Adj. Flow (vph)	141	803	60	374	1183	318	28	367	169	122	266	20
RTOR Reduction (vph)	0	9	0	0	40	0	0	90	0	0	9	0
Lane Group Flow (vph)	141	854	0	374	1461	0	28	446	0	122	277	0
Turn Type	pm+pt			Prot			Perm			Perm		
Protected Phases	7	4		3	8			2				6
Permitted Phases	4						2			6		
Actuated Green, G (s)	24.0	20.0		11.0	27.0		17.0	17.0		17.0	17.0	
Effective Green, g (s)	24.0	20.0		11.0	27.0		17.0	17.0		17.0	17.0	
Actuated g/C Ratio	0.40	0.33		0.18	0.45		0.28	0.28		0.28	0.28	
Clearance Time (s)	4.0	4.0		4.0	4.0		4.0	4.0		4.0	4.0	
Lane Grp Cap (vph)	242	1167		629	1542		304	955		183	992	
v/s Ratio Prot	0.04	0.24		c0.11	c0.43			0.13			0.08	
v/s Ratio Perm	0.19						0.03			c0.19		
v/c Ratio	0.58	0.73		0.59	0.95		0.09	0.47		0.67	0.28	
Uniform Delay, d <sub>1</sub>	13.8	17.6		22.5	15.8		15.8	17.8		19.0	16.7	
Progression Factor	1.00	1.00		1.00	1.00		1.00	1.00		0.52	0.42	
Incremental Delay, d <sub>2</sub>	9.9	4.1		4.1	13.4		0.6	1.6		13.6	0.5	
Delay (s)	23.6	21.7		26.6	29.2		16.4	19.4		23.4	7.6	
Level of Service	C	C		C	C		B	B		C	A	
Approach Delay (s)		22.0			28.7			19.3			12.4	
Approach LOS		C			C			B			B	
<b>Intersection Summary</b>												
HCM Average Control Delay			23.8			HCM Level of Service				C		
HCM Volume to Capacity ratio			0.84									
Actuated Cycle Length (s)			60.0			Sum of lost time (s)			12.0			
Intersection Capacity Utilization			79.0%			ICU Level of Service				D		
Analysis Period (min)			15									

c Critical Lane Group

HCM Signalized Intersection Capacity Analysis  
 11: University Drive & Meridain Road

2035 PM  
 2/4/2013

												
Movement	EBL	EBT	EBR	WBL	WBT	WBR	NBL	NBT	NBR	SBL	SBT	SBR
Lane Configurations		 			 			 			 	
Volume (vph)	73	883	262	46	253	53	156	188	124	95	208	43
Ideal Flow (vphpl)	1900	1900	1900	1900	1900	1900	1900	1900	1900	1900	1900	1900
Total Lost time (s)	4.0	4.0		4.0	4.0		4.0	4.0		4.0	4.0	4.0
Lane Util. Factor	1.00	0.95		1.00	0.95		1.00	0.95		1.00	0.95	1.00
Flt	1.00	0.97		1.00	0.97		1.00	0.94		1.00	1.00	0.85
Flt Protected	0.95	1.00		0.95	1.00		0.95	1.00		0.95	1.00	1.00
Satd. Flow (prot)	1770	3418		1770	3447		1770	3328		1770	3539	1583
Flt Permitted	0.55	1.00		0.14	1.00		0.61	1.00		0.53	1.00	1.00
Satd. Flow (perm)	1019	3418		260	3447		1132	3328		995	3539	1583
Peak-hour factor, PHF	0.90	0.90	0.90	0.90	0.90	0.90	0.90	0.90	0.90	0.90	0.90	0.90
Adj. Flow (vph)	81	981	291	51	281	59	173	209	138	106	231	48
RTOR Reduction (vph)	0	50	0	0	27	0	0	70	0	0	0	33
Lane Group Flow (vph)	81	1222	0	51	313	0	173	277	0	106	231	15
Turn Type	Perm			Perm			Perm			Perm		Perm
Protected Phases		4			8			2			6	
Permitted Phases	4			8			2			6		6
Actuated Green, G (s)	30.0	30.0		30.0	30.0		17.0	17.0		17.0	17.0	17.0
Effective Green, g (s)	30.0	30.0		30.0	30.0		17.0	17.0		17.0	17.0	17.0
Actuated g/C Ratio	0.55	0.55		0.55	0.55		0.31	0.31		0.31	0.31	0.31
Clearance Time (s)	4.0	4.0		4.0	4.0		4.0	4.0		4.0	4.0	4.0
Lane Grp Cap (vph)	556	1864		142	1880		350	1029		308	1094	489
v/s Ratio Prot		c0.36			0.09			0.08			0.07	
v/s Ratio Perm	0.08			0.20			c0.15			0.11		0.01
v/c Ratio	0.15	0.66		0.36	0.17		0.49	0.27		0.34	0.21	0.03
Uniform Delay, d1	6.2	8.8		7.1	6.2		15.5	14.3		14.7	14.0	13.3
Progression Factor	1.00	1.00		1.00	1.00		1.00	1.00		1.00	1.00	1.00
Incremental Delay, d2	0.6	1.8		6.9	0.2		4.9	0.6		3.0	0.4	0.1
Delay (s)	6.7	10.7		14.0	6.4		20.4	15.0		17.7	14.5	13.4
Level of Service	A	B		B	A		C	B		B	B	B
Approach Delay (s)		10.4			7.4			16.8			15.2	
Approach LOS		B			A			B			B	
<b>Intersection Summary</b>												
HCM Average Control Delay			11.9			HCM Level of Service				B		
HCM Volume to Capacity ratio			0.60									
Actuated Cycle Length (s)			55.0			Sum of lost time (s)			8.0			
Intersection Capacity Utilization			63.9%			ICU Level of Service				B		
Analysis Period (min)			15									

c Critical Lane Group

HCM Signalized Intersection Capacity Analysis  
 17: Apache Trail & Meridain Road

2035 PM  
 2/4/2013

Movement	EBL	EBT	EBR	WBL	WBT	WBR	NBL	NBT	NBR	SBL	SBT	SBR
Lane Configurations												
Volume (vph)	85	1171	205	309	1057	172	188	218	426	149	300	57
Ideal Flow (vphpl)	1900	1900	1900	1900	1900	1900	1900	1900	1900	1900	1900	1900
Total Lost time (s)	4.0	4.0	4.0	4.0	4.0	4.0	4.0	4.0		4.0	4.0	
Lane Util. Factor	1.00	0.91	1.00	0.97	0.91	1.00	1.00	0.95		1.00	0.95	
Frt	1.00	1.00	0.85	1.00	1.00	0.85	1.00	0.90		1.00	0.98	
Flt Protected	0.95	1.00	1.00	0.95	1.00	1.00	0.95	1.00		0.95	1.00	
Satd. Flow (prot)	1770	5085	1583	3433	5085	1583	1770	3188		1770	3455	
Flt Permitted	0.24	1.00	1.00	0.95	1.00	1.00	0.46	1.00		0.25	1.00	
Satd. Flow (perm)	438	5085	1583	3433	5085	1583	859	3188		466	3455	
Peak-hour factor, PHF	0.90	0.90	0.90	0.90	0.90	0.90	0.90	0.90	0.90	0.90	0.90	0.90
Adj. Flow (vph)	94	1301	228	343	1174	191	209	242	473	166	333	63
RTOR Reduction (vph)	0	0	163	0	0	127	0	155	0	0	26	0
Lane Group Flow (vph)	94	1301	65	343	1174	64	209	560	0	166	370	0
Turn Type	pm+pt		Perm	Prot		Perm	pm+pt			pm+pt		
Protected Phases	7	4		3	8		5	2		1	6	
Permitted Phases	4		4			8	2			6		
Actuated Green, G (s)	21.0	17.0	17.0	7.0	20.0	20.0	20.0	16.0		20.0	16.0	
Effective Green, g (s)	21.0	17.0	17.0	7.0	20.0	20.0	20.0	16.0		20.0	16.0	
Actuated g/C Ratio	0.35	0.28	0.28	0.12	0.33	0.33	0.33	0.27		0.33	0.27	
Clearance Time (s)	4.0	4.0	4.0	4.0	4.0	4.0	4.0	4.0		4.0	4.0	
Lane Grp Cap (vph)	242	1441	449	401	1695	528	347	850		242	921	
v/s Ratio Prot	0.03	c0.26		c0.10	c0.23		0.04	0.18		c0.05	0.11	
v/s Ratio Perm	0.11		0.04			0.04	0.16			c0.18		
v/c Ratio	0.39	0.90	0.14	0.86	0.69	0.12	0.60	0.66		0.69	0.40	
Uniform Delay, d1	13.7	20.7	16.1	26.0	17.3	13.9	15.7	19.6		15.5	18.1	
Progression Factor	1.00	1.00	1.00	1.00	1.00	1.00	1.00	1.00		1.00	1.00	
Incremental Delay, d2	4.6	9.5	0.7	20.2	2.4	0.5	7.5	4.0		14.7	1.3	
Delay (s)	18.3	30.2	16.7	46.3	19.7	14.4	23.2	23.6		30.2	19.4	
Level of Service	B	C	B	D	B	B	C	C		C	B	
Approach Delay (s)		27.6			24.4			23.5			22.6	
Approach LOS		C			C			C			C	

Intersection Summary

HCM Average Control Delay	25.1	HCM Level of Service	C
HCM Volume to Capacity ratio	0.85		
Actuated Cycle Length (s)	60.0	Sum of lost time (s)	20.0
Intersection Capacity Utilization	72.8%	ICU Level of Service	C
Analysis Period (min)	15		

c Critical Lane Group



HCM Signalized Intersection Capacity Analysis  
22: Broadway Avenue & Meridain Road

2035 PM  
2/4/2013



























Movement	EBL	EBT	EBR	WBL	WBT	WBR	NBL	NBT	NBR	SBL	SBT	SBR
Lane Configurations												
Volume (vph)	71	374	187	362	637	220	296	608	284	186	515	67
Ideal Flow (vphpl)	1900	1900	1900	1900	1900	1900	1900	1900	1900	1900	1900	1900
Total Lost time (s)	4.0	4.0	4.0	4.0	4.0		4.0	4.0	4.0	4.0	4.0	
Lane Util. Factor	1.00	0.95	1.00	0.97	0.95		1.00	0.95	1.00	1.00	0.95	
Frt	1.00	1.00	0.85	1.00	0.96		1.00	1.00	0.85	1.00	0.98	
Flt Protected	0.95	1.00	1.00	0.95	1.00		0.95	1.00	1.00	0.95	1.00	
Satd. Flow (prot)	1770	3539	1583	3433	3403		1770	3539	1583	1770	3478	
Flt Permitted	0.25	1.00	1.00	0.95	1.00		0.21	1.00	1.00	0.27	1.00	
Satd. Flow (perm)	466	3539	1583	3433	3403		392	3539	1583	505	3478	
Peak-hour factor, PHF	0.90	0.90	0.90	0.90	0.90	0.90	0.90	0.90	0.90	0.90	0.90	0.90
Adj. Flow (vph)	79	416	208	402	708	244	329	676	316	207	572	74
RTOR Reduction (vph)	0	0	157	0	53	0	0	0	205	0	16	0
Lane Group Flow (vph)	79	416	51	402	899	0	329	676	111	207	630	0
Turn Type	pm+pt		Perm	Prot			pm+pt		Perm	pm+pt		
Protected Phases	7	4		3	8		5	2		1	6	
Permitted Phases	4		4				2		2	6		
Actuated Green, G (s)	20.0	16.0	16.0	8.0	20.0		27.0	19.0	19.0	23.0	17.0	
Effective Green, g (s)	20.0	16.0	16.0	8.0	20.0		27.0	19.0	19.0	23.0	17.0	
Actuated g/C Ratio	0.31	0.25	0.25	0.12	0.31		0.42	0.29	0.29	0.35	0.26	
Clearance Time (s)	4.0	4.0	4.0	4.0	4.0		4.0	4.0	4.0	4.0	4.0	
Lane Grp Cap (vph)	224	871	390	423	1047		332	1034	463	295	910	
v/s Ratio Prot	0.02	0.12		c0.12	c0.26		c0.12	0.19		0.06	0.18	
v/s Ratio Perm	0.09		0.03				c0.29		0.07	0.18		
v/c Ratio	0.35	0.48	0.13	0.95	0.86		0.99	0.65	0.24	0.70	0.69	
Uniform Delay, d1	17.0	20.9	19.1	28.3	21.2		15.6	20.1	17.5	15.7	21.6	
Progression Factor	1.00	1.00	1.00	1.00	1.00		1.00	1.00	1.00	1.00	1.00	
Incremental Delay, d2	4.3	1.9	0.7	32.9	9.2		47.2	3.2	1.2	13.1	4.3	
Delay (s)	21.3	22.8	19.8	61.2	30.3		62.7	23.3	18.7	28.7	26.0	
Level of Service	C	C	B	E	C		E	C	B	C	C	
Approach Delay (s)		21.7			39.5			32.1			26.6	
Approach LOS		C			D			C			C	

Intersection Summary		
HCM Average Control Delay	31.6	HCM Level of Service C
HCM Volume to Capacity ratio	1.00	
Actuated Cycle Length (s)	65.0	Sum of lost time (s) 16.0
Intersection Capacity Utilization	74.7%	ICU Level of Service D
Analysis Period (min)	15	

c Critical Lane Group

HCM Signalized Intersection Capacity Analysis  
 27: Southern Avenue & Meridain Road

2035 PM  
 2/4/2013

												
Movement	EBL	EBT	EBR	WBL	WBT	WBR	NBL	NBT	NBR	SBL	SBT	SBR
Lane Configurations		 			 		 	 			 	
Volume (vph)	269	360	60	264	356	342	171	568	583	82	951	48
Ideal Flow (vphpl)	1900	1900	1900	1900	1900	1900	1900	1900	1900	1900	1900	1900
Total Lost time (s)	4.0	4.0		4.0	4.0	4.0	4.0	4.0	4.0	4.0	4.0	
Lane Util. Factor	1.00	0.95		1.00	0.95	1.00	0.97	0.95	1.00	1.00	0.95	
Flt	1.00	0.98		1.00	1.00	0.85	1.00	1.00	0.85	1.00	0.99	
Flt Protected	0.95	1.00		0.95	1.00	1.00	0.95	1.00	1.00	0.95	1.00	
Satd. Flow (prot)	1770	3463		1770	3539	1583	3433	3539	1583	1770	3514	
Flt Permitted	0.40	1.00		0.48	1.00	1.00	0.95	1.00	1.00	0.31	1.00	
Satd. Flow (perm)	751	3463		901	3539	1583	3433	3539	1583	570	3514	
Peak-hour factor, PHF	0.90	0.90	0.90	0.90	0.90	0.90	0.90	0.90	0.90	0.90	0.90	0.90
Adj. Flow (vph)	299	400	67	293	396	380	190	631	648	91	1057	53
RTOR Reduction (vph)	0	15	0	0	0	66	0	0	235	0	4	0
Lane Group Flow (vph)	299	452	0	293	396	314	190	631	413	91	1106	0
Turn Type	pm+pt			Perm		pm+ov	Prot		Perm	pm+pt		
Protected Phases	7	4				8	1	5	2		1	6
Permitted Phases	4			8			8			2	6	
Actuated Green, G (s)	38.8	38.8		30.8	30.8	36.8	6.4	33.2	33.2	38.8	32.8	
Effective Green, g (s)	38.8	38.8		30.8	30.8	36.8	6.4	33.2	33.2	38.8	32.8	
Actuated g/C Ratio	0.43	0.43		0.34	0.34	0.41	0.07	0.37	0.37	0.43	0.36	
Clearance Time (s)	4.0	4.0		4.0	4.0	4.0	4.0	4.0	4.0	4.0	4.0	
Vehicle Extension (s)	3.0	3.0		3.0	3.0	3.0	3.0	3.0	3.0	3.0	3.0	
Lane Grp Cap (vph)	369	1493		308	1211	718	244	1305	584	326	1281	
v/s Ratio Prot	c0.04	0.13			0.11	0.03	c0.06	0.18		0.02	c0.31	
v/s Ratio Perm	0.31			c0.33		0.17			0.26	0.10		
v/c Ratio	0.81	0.30		0.95	0.33	0.44	0.78	0.48	0.71	0.28	0.86	
Uniform Delay, d1	23.3	16.7		28.9	21.9	19.1	41.1	21.8	24.2	15.8	26.5	
Progression Factor	1.00	1.00		1.00	1.00	1.00	1.00	1.00	1.00	1.00	1.00	
Incremental Delay, d2	12.6	0.1		38.3	0.2	0.4	14.5	1.3	7.0	0.5	7.9	
Delay (s)	35.9	16.9		67.1	22.1	19.6	55.6	23.1	31.3	16.3	34.4	
Level of Service	D	B		E	C	B	E	C	C	B	C	
Approach Delay (s)		24.3			33.5			30.9			33.0	
Approach LOS		C			C			C			C	
<b>Intersection Summary</b>												
HCM Average Control Delay			31.0				HCM Level of Service			C		
HCM Volume to Capacity ratio			0.90									
Actuated Cycle Length (s)			90.0				Sum of lost time (s)		16.0			
Intersection Capacity Utilization			72.5%				ICU Level of Service		C			
Analysis Period (min)			15									
c Critical Lane Group												

# HCM Signalized Intersection Capacity Analysis

## 68: US 60 WB On-Ramp & Meridain Road

2035 PM  
2/4/2013



Movement	EBL	EBR	NBL	NBT	SBT	SBR
Lane Configurations			↔↔	↑↑	↑↑	↗
Volume (vph)	0	0	418	386	480	184
Ideal Flow (vphpl)	1900	1900	1900	1900	1900	1900
Total Lost time (s)			4.0	4.0	4.0	4.0
Lane Util. Factor			0.97	0.95	0.95	1.00
Flt			1.00	1.00	1.00	0.85
Flt Protected			0.95	1.00	1.00	1.00
Satd. Flow (prot)			3433	3539	3539	1583
Flt Permitted			0.13	1.00	1.00	1.00
Satd. Flow (perm)			487	3539	3539	1583
Peak-hour factor, PHF	0.90	0.90	0.90	0.90	0.90	0.90
Adj. Flow (vph)	0	0	464	429	533	204
RTOR Reduction (vph)	0	0	0	0	0	150
Lane Group Flow (vph)	0	0	464	429	533	54
Turn Type			pm+pt			Perm
Protected Phases			2	5 6	6	
Permitted Phases			5 6			6
Actuated Green, G (s)			56.0	60.0	16.0	16.0
Effective Green, g (s)			56.0	60.0	16.0	16.0
Actuated g/C Ratio			0.93	1.00	0.27	0.27
Clearance Time (s)			4.0		4.0	4.0
Lane Grp Cap (vph)			1240	3539	944	422
v/s Ratio Prot			c0.10	0.12	c0.15	
v/s Ratio Perm			c0.25			0.03
v/c Ratio			0.37	0.12	0.56	0.13
Uniform Delay, d1			9.3	0.0	19.0	16.7
Progression Factor			0.24	1.00	1.00	1.00
Incremental Delay, d2			0.7	0.1	2.4	0.6
Delay (s)			3.0	0.1	21.4	17.3
Level of Service			A	A	C	B
Approach Delay (s)	0.0			1.6	20.3	
Approach LOS	A			A	C	

### Intersection Summary















HCM Average Control Delay	10.0	HCM Level of Service	B
HCM Volume to Capacity ratio	0.43		
Actuated Cycle Length (s)	60.0	Sum of lost time (s)	8.0
Intersection Capacity Utilization	70.2%	ICU Level of Service	C
Analysis Period (min)	15		

c Critical Lane Group

# HCM Signalized Intersection Capacity Analysis

## 71: US 60 EB Off-Ramp & Meridain Road

2035 PM  
2/4/2013

						
Movement	EBL	EBR	NBL	NBT	SBT	SBR
Lane Configurations		 		  	 	
Volume (vph)	254	1437	0	804	480	0
Ideal Flow (vphpl)	1900	1900	1900	1900	1900	1900
Grade (%)	1%			0%	0%	
Total Lost time (s)	4.0	4.0		4.0	4.0	
Lane Util. Factor	1.00	0.88		0.91	0.95	
Frt	1.00	0.85		1.00	1.00	
Flt Protected	0.95	1.00		1.00	1.00	
Satd. Flow (prot)	1761	2773		5085	3539	
Flt Permitted	0.95	1.00		1.00	1.00	
Satd. Flow (perm)	1761	2773		5085	3539	
Peak-hour factor, PHF	0.90	0.90	0.90	0.90	0.90	0.90
Adj. Flow (vph)	282	1597	0	893	533	0
RTOR Reduction (vph)	0	54	0	0	0	0
Lane Group Flow (vph)	282	1543	0	893	533	0
Turn Type	Perm					
Protected Phases	4 12			2	2	
Permitted Phases		4 12				
Actuated Green, G (s)	36.0	36.0		16.0	16.0	
Effective Green, g (s)	36.0	36.0		16.0	16.0	
Actuated g/C Ratio	0.60	0.60		0.27	0.27	
Clearance Time (s)				4.0	4.0	
Lane Grp Cap (vph)	1057	1664		1356	944	
v/s Ratio Prot	0.16			c0.18	0.15	
v/s Ratio Perm		c0.56				
v/c Ratio	0.27	0.93		0.66	0.56	
Uniform Delay, d1	5.7	10.8		19.6	19.0	
Progression Factor	1.00	1.00		1.00	0.77	
Incremental Delay, d2	0.6	10.5		2.5	2.0	
Delay (s)	6.3	21.3		22.1	16.8	
Level of Service	A	C		C	B	
Approach Delay (s)	19.1			22.1	16.8	
Approach LOS	B			C	B	
<b>Intersection Summary</b>						
HCM Average Control Delay			19.5	HCM Level of Service		B
HCM Volume to Capacity ratio			0.84			
Actuated Cycle Length (s)			60.0	Sum of lost time (s)		8.0
Intersection Capacity Utilization			70.2%	ICU Level of Service		C
Analysis Period (min)			15			
c Critical Lane Group						

HCM Signalized Intersection Capacity Analysis  
 31: Baseline Road & Meridain Road

2035 PM  
 2/4/2013

Movement	EBL	EBT	EBR	WBL	WBT	WBR	NBL	NBT	NBR	SBL	SBT	SBR
Lane Configurations												
Volume (vph)	160	1085	286	42	246	549	18	243	95	407	1453	38
Ideal Flow (vphpl)	1900	1900	1900	1900	1900	1900	1900	1900	1900	1900	1900	1900
Total Lost time (s)	4.0	4.0		4.0	4.0	4.0	4.0	4.0		4.0	4.0	4.0
Lane Util. Factor	1.00	0.91		1.00	0.95	0.88	1.00	0.91		0.97	0.95	1.00
Flt	1.00	0.97		1.00	1.00	0.85	1.00	0.96		1.00	1.00	0.85
Flt Protected	0.95	1.00		0.95	1.00	1.00	0.95	1.00		0.95	1.00	1.00
Satd. Flow (prot)	1770	4926		1770	3539	2787	1770	4870		3433	3539	1583
Flt Permitted	0.46	1.00		0.18	1.00	1.00	0.15	1.00		0.95	1.00	1.00
Satd. Flow (perm)	848	4926		330	3539	2787	277	4870		3433	3539	1583
Peak-hour factor, PHF	0.90	0.90	0.90	0.90	0.90	0.90	0.90	0.90	0.90	0.90	0.90	0.90
Adj. Flow (vph)	178	1206	318	47	273	610	20	270	106	452	1614	42
RTOR Reduction (vph)	0	50	0	0	0	344	0	74	0	0	0	11
Lane Group Flow (vph)	178	1474	0	47	273	266	20	302	0	452	1614	31
Turn Type	pm+pt			pm+pt		pm+ov	pm+pt			Prot		Perm
Protected Phases	7	4		3	8	1	5	2		1	6	
Permitted Phases	4			8		8	2					6
Actuated Green, G (s)	34.6	28.2		25.0	22.6	39.1	28.5	26.9		16.5	41.8	41.8
Effective Green, g (s)	34.6	28.2		25.0	22.6	39.1	28.5	26.9		16.5	41.8	41.8
Actuated g/C Ratio	0.38	0.31		0.28	0.25	0.43	0.32	0.30		0.18	0.46	0.46
Clearance Time (s)	4.0	4.0		4.0	4.0	4.0	4.0	4.0		4.0	4.0	4.0
Vehicle Extension (s)	3.0	3.0		3.0	3.0	3.0	3.0	3.0		3.0	3.0	3.0
Lane Grp Cap (vph)	408	1543		130	889	1335	114	1456		629	1644	735
v/s Ratio Prot	c0.04	c0.30		0.01	0.08	0.04	0.00	0.06		c0.13	c0.46	
v/s Ratio Perm	0.13			0.09		0.06	0.05					0.02
v/c Ratio	0.44	0.96		0.36	0.31	0.20	0.18	0.21		0.72	0.98	0.04
Uniform Delay, d1	19.2	30.3		26.0	27.3	15.8	24.2	23.6		34.6	23.7	13.2
Progression Factor	1.00	1.00		1.00	1.00	1.00	1.00	1.00		1.00	1.00	1.00
Incremental Delay, d2	0.7	13.6		1.7	0.2	0.1	0.7	0.3		3.9	18.3	0.1
Delay (s)	19.9	43.9		27.7	27.5	15.8	24.9	23.9		38.5	42.0	13.3
Level of Service	B	D		C	C	B	C	C		D	D	B
Approach Delay (s)		41.4			19.9			24.0			40.7	
Approach LOS		D			B			C			D	

Intersection Summary

























HCM Average Control Delay	35.9	HCM Level of Service	D
HCM Volume to Capacity ratio	0.97		
Actuated Cycle Length (s)	90.0	Sum of lost time (s)	16.0
Intersection Capacity Utilization	87.5%	ICU Level of Service	E
Analysis Period (min)	15		
c Critical Lane Group			



# HCM Signalized Intersection Capacity Analysis

## 2: Guadalupe Road & Meridian Road

2035 PM  
2/4/2013

























												
Movement	EBL	EBT	EBR	WBL	WBT	WBR	NBL	NBT	NBR	SBL	SBT	SBR
Lane Configurations		 			 			 			 	
Volume (vph)	72	359	48	69	347	46	129	645	86	184	921	123
Ideal Flow (vphpl)	1900	1900	1900	1900	1900	1900	1900	1900	1900	1900	1900	1900
Total Lost time (s)	4.0	4.0		4.0	4.0		4.0	4.0		4.0	4.0	
Lane Util. Factor	1.00	0.95		1.00	0.95		1.00	0.95		1.00	0.95	
Flt	1.00	0.98		1.00	0.98		1.00	0.98		1.00	0.98	
Flt Protected	0.95	1.00		0.95	1.00		0.95	1.00		0.95	1.00	
Satd. Flow (prot)	1770	3477		1770	3477		1770	3477		1770	3477	
Flt Permitted	0.42	1.00		0.41	1.00		0.19	1.00		0.31	1.00	
Satd. Flow (perm)	786	3477		760	3477		350	3477		580	3477	
Peak-hour factor, PHF	0.90	0.90	0.90	0.90	0.90	0.90	0.90	0.90	0.90	0.90	0.90	0.90
Adj. Flow (vph)	80	399	53	77	386	51	143	717	96	204	1023	137
RTOR Reduction (vph)	0	17	0	0	17	0	0	17	0	0	17	0
Lane Group Flow (vph)	80	435	0	77	420	0	143	796	0	204	1143	0
Turn Type	Perm			Perm			Perm			Perm		
Protected Phases		4			8			2			6	
Permitted Phases	4			8			2			6		
Actuated Green, G (s)	16.0	16.0		16.0	16.0		36.0	36.0		36.0	36.0	
Effective Green, g (s)	16.0	16.0		16.0	16.0		36.0	36.0		36.0	36.0	
Actuated g/C Ratio	0.27	0.27		0.27	0.27		0.60	0.60		0.60	0.60	
Clearance Time (s)	4.0	4.0		4.0	4.0		4.0	4.0		4.0	4.0	
Lane Grp Cap (vph)	210	927		203	927		210	2086		348	2086	
v/s Ratio Prot		c0.13			0.12			0.23			0.33	
v/s Ratio Perm	0.10			0.10			c0.41			0.35		
v/c Ratio	0.38	0.47		0.38	0.45		0.68	0.38		0.59	0.55	
Uniform Delay, d1	18.0	18.4		17.9	18.4		8.1	6.2		7.4	7.2	
Progression Factor	1.00	1.00		1.00	1.00		1.00	1.00		1.00	1.00	
Incremental Delay, d2	5.2	1.7		5.3	1.6		16.4	0.5		7.1	1.0	
Delay (s)	23.1	20.1		23.3	20.0		24.5	6.8		14.5	8.2	
Level of Service	C	C		C	B		C	A		B	A	
Approach Delay (s)		20.6			20.4			9.4			9.1	
Approach LOS		C			C			A			A	
<b>Intersection Summary</b>												
HCM Average Control Delay			12.8			HCM Level of Service				B		
HCM Volume to Capacity ratio			0.62									
Actuated Cycle Length (s)			60.0			Sum of lost time (s)			8.0			
Intersection Capacity Utilization			65.1%			ICU Level of Service			C			
Analysis Period (min)			15									

c Critical Lane Group

# HCM Signalized Intersection Capacity Analysis

## 35: Elliot Road & Meridian Road























2035 PM  
2/4/2013

												
Movement	EBL	EBT	EBR	WBL	WBT	WBR	NBL	NBT	NBR	SBL	SBT	SBR
Lane Configurations		 			 			 			 	
Volume (vph)	139	695	93	123	613	82	52	715	165	78	583	123
Ideal Flow (vphpl)	1900	1900	1900	1900	1900	1900	1900	1900	1900	1900	1900	1900
Total Lost time (s)	4.0	4.0		4.0	4.0		4.0	4.0		4.0	4.0	
Lane Util. Factor	1.00	0.91		1.00	0.91		0.97	0.95		1.00	0.95	
Fr <sub>t</sub>	1.00	0.98		1.00	0.98		1.00	0.97		1.00	0.97	
Fl <sub>t</sub> Protected	0.95	1.00		0.95	1.00		0.95	1.00		0.95	1.00	
Satd. Flow (prot)	1770	4996		1770	4995		3433	3440		1770	3447	
Fl <sub>t</sub> Permitted	0.27	1.00		0.27	1.00		0.95	1.00		0.19	1.00	
Satd. Flow (perm)	507	4996		507	4995		3433	3440		351	3447	
Peak-hour factor, PHF	0.90	0.90	0.90	0.90	0.90	0.90	0.90	0.90	0.90	0.90	0.90	0.90
Adj. Flow (vph)	154	772	103	137	681	91	58	794	183	87	648	137
RTOR Reduction (vph)	0	29	0	0	29	0	0	32	0	0	28	0
Lane Group Flow (vph)	154	846	0	137	743	0	58	945	0	87	757	0
Turn Type	pm+pt			pm+pt			Prot			pm+pt		
Protected Phases	7	4		3	8		5	2		1	6	
Permitted Phases	4			8						6		
Actuated Green, G (s)	18.4	14.7		18.4	14.7		2.2	20.4		24.2	21.2	
Effective Green, g (s)	18.4	14.7		18.4	14.7		2.2	20.4		24.2	21.2	
Actuated g/C Ratio	0.32	0.25		0.32	0.25		0.04	0.35		0.42	0.37	
Clearance Time (s)	4.0	4.0		4.0	4.0		4.0	4.0		4.0	4.0	
Vehicle Extension (s)	3.0	3.0		3.0	3.0		3.0	3.0		3.0	3.0	
Lane Grp Cap (vph)	242	1271		242	1270		131	1214		221	1264	
v/s Ratio Prot	c0.04	c0.17		0.04	0.15		0.02	c0.27		c0.02	0.22	
v/s Ratio Perm	0.16			0.14						0.14		
v/c Ratio	0.64	0.67		0.57	0.58		0.44	0.78		0.39	0.60	
Uniform Delay, d <sub>1</sub>	14.9	19.3		14.9	18.9		27.2	16.7		11.6	14.9	
Progression Factor	1.00	1.00		1.00	1.00		1.00	1.00		1.00	1.00	
Incremental Delay, d <sub>2</sub>	5.4	1.3		3.0	0.7		2.4	5.0		1.2	2.1	
Delay (s)	20.3	20.7		17.9	19.6		29.6	21.7		12.8	17.0	
Level of Service	C	C		B	B		C	C		B	B	
Approach Delay (s)	20.6			19.3			22.1			16.5		
Approach LOS	C			B			C			B		
<b>Intersection Summary</b>												
HCM Average Control Delay			19.8			HCM Level of Service			B			
HCM Volume to Capacity ratio			0.70									
Actuated Cycle Length (s)			57.8			Sum of lost time (s)			16.0			
Intersection Capacity Utilization			65.0%			ICU Level of Service			C			
Analysis Period (min)			15									
c Critical Lane Group												

# HCM Signalized Intersection Capacity Analysis

## 37: Warner Road & Meridian Road





























2035 PM  
2/4/2013

												
Movement	EBL	EBT	EBR	WBL	WBT	WBR	NBL	NBT	NBR	SBL	SBT	SBR
Lane Configurations												
Volume (vph)	339	1715	208	121	606	81	88	397	66	90	452	60
Ideal Flow (vphpl)	1900	1900	1900	1900	1900	1900	1900	1900	1900	1900	1900	1900
Total Lost time (s)	4.0	4.0	4.0	4.0	4.0		4.0	4.0		4.0	4.0	
Lane Util. Factor	0.97	0.91	1.00	1.00	0.91		1.00	0.95		1.00	0.95	
Frt	1.00	1.00	0.85	1.00	0.98		1.00	0.98		1.00	0.98	
Flt Protected	0.95	1.00	1.00	0.95	1.00		0.95	1.00		0.95	1.00	
Satd. Flow (prot)	3433	5085	1583	1770	4995		1770	3464		1770	3477	
Flt Permitted	0.95	1.00	1.00	0.22	1.00		0.28	1.00		0.33	1.00	
Satd. Flow (perm)	3433	5085	1583	403	4995		524	3464		612	3477	
Peak-hour factor, PHF	0.90	0.90	0.90	0.90	0.90	0.90	0.90	0.90	0.90	0.90	0.90	0.90
Adj. Flow (vph)	377	1906	231	134	673	90	98	441	73	100	502	67
RTOR Reduction (vph)	0	0	123	0	26	0	0	20	0	0	16	0
Lane Group Flow (vph)	377	1906	108	134	737	0	98	494	0	100	553	0
Turn Type	Prot		Perm	pm+pt			pm+pt			pm+pt		
Protected Phases	7	4		3	8		5	2		1	6	
Permitted Phases			4	8			2			6		
Actuated Green, G (s)	11.2	26.5	26.5	21.7	18.5		19.3	16.1		19.3	16.1	
Effective Green, g (s)	11.2	26.5	26.5	21.7	18.5		19.3	16.1		19.3	16.1	
Actuated g/C Ratio	0.17	0.41	0.41	0.33	0.28		0.30	0.25		0.30	0.25	
Clearance Time (s)	4.0	4.0	4.0	4.0	4.0		4.0	4.0		4.0	4.0	
Vehicle Extension (s)	3.0	3.0	3.0	3.0	3.0		3.0	3.0		3.0	3.0	
Lane Grp Cap (vph)	592	2073	645	202	1422		217	858		239	861	
v/s Ratio Prot	c0.11	c0.37		0.03	0.15		c0.02	0.14		0.02	c0.16	
v/s Ratio Perm			0.07	0.19			0.11			0.10		
v/c Ratio	0.64	0.92	0.17	0.66	0.52		0.45	0.58		0.42	0.64	
Uniform Delay, d1	25.0	18.2	12.2	17.8	19.5		17.3	21.5		17.2	21.9	
Progression Factor	1.00	1.00	1.00	1.00	1.00		1.00	1.00		1.00	1.00	
Incremental Delay, d2	2.3	7.1	0.1	7.9	0.3		1.5	2.8		1.2	3.7	
Delay (s)	27.3	25.3	12.4	25.8	19.8		18.8	24.3		18.4	25.5	
Level of Service	C	C	B	C	B		B	C		B	C	
Approach Delay (s)		24.4			20.7			23.4			24.5	
Approach LOS		C			C			C			C	
<b>Intersection Summary</b>												
HCM Average Control Delay			23.6			HCM Level of Service				C		
HCM Volume to Capacity ratio			0.80									
Actuated Cycle Length (s)			65.0			Sum of lost time (s)		16.0				
Intersection Capacity Utilization			72.5%			ICU Level of Service				C		
Analysis Period (min)			15									
c Critical Lane Group												

# HCM Signalized Intersection Capacity Analysis





















## 41: Ray Road & Meridian Road

2035 PM  
2/4/2013

													
Movement	EBL	EBT	EBR	WBL	WBT	WBR	NBL	NBT	NBR	SBL	SBT	SBR	
Lane Configurations	 	 		 	 		 	 		 	 		
Volume (vph)	207	1013	172	56	666	389	31	135	42	109	219	36	
Ideal Flow (vphpl)	1900	1900	1900	1900	1900	1900	1900	1900	1900	1900	1900	1900	
Total Lost time (s)	4.0	4.0		4.0	4.0	4.0	4.0	4.0		4.0	4.0		
Lane Util. Factor	0.97	0.91		0.97	0.91	1.00	1.00	0.95		1.00	0.95		
Fr <sub>t</sub>	1.00	0.98		1.00	1.00	0.85	1.00	0.96		1.00	0.98		
Fl <sub>t</sub> Protected	0.95	1.00		0.95	1.00	1.00	0.95	1.00		0.95	1.00		
Satd. Flow (prot)	3433	4975		3433	5085	1583	1770	3413		1770	3464		
Fl <sub>t</sub> Permitted	0.95	1.00		0.95	1.00	1.00	0.47	1.00		0.63	1.00		
Satd. Flow (perm)	3433	4975		3433	5085	1583	878	3413		1170	3464		
Peak-hour factor, PHF	0.90	0.90	0.90	0.90	0.90	0.90	0.90	0.90	0.90	0.90	0.90	0.90	
Adj. Flow (vph)	230	1126	191	62	740	432	34	150	47	121	243	40	
RTOR Reduction (vph)	0	37	0	0	0	310	0	29	0	0	21	0	
Lane Group Flow (vph)	230	1280	0	62	740	122	34	168	0	121	262	0	
Turn Type	Prot			Prot		Perm	pm+pt			Perm			
Protected Phases	7	4		3	8		5	2				6	
Permitted Phases						8	2			6			
Actuated Green, G (s)	7.8	22.3		2.4	16.9	16.9	23.3	23.3		17.7	17.7		
Effective Green, g (s)	7.8	22.3		2.4	16.9	16.9	23.3	23.3		17.7	17.7		
Actuated g/C Ratio	0.13	0.37		0.04	0.28	0.28	0.39	0.39		0.29	0.29		
Clearance Time (s)	4.0	4.0		4.0	4.0	4.0	4.0	4.0		4.0	4.0		
Vehicle Extension (s)	3.0	3.0		3.0	3.0	3.0	3.0	3.0		3.0	3.0		
Lane Grp Cap (vph)	446	1849		137	1432	446	365	1325		345	1022		
v/s Ratio Prot	c0.07	c0.26		0.02	0.15		0.00	c0.05			0.08		
v/s Ratio Perm						0.08	0.03			c0.10			
v/c Ratio	0.52	0.69		0.45	0.52	0.27	0.09	0.13		0.35	0.26		
Uniform Delay, d <sub>1</sub>	24.3	15.9		28.2	18.1	16.8	11.6	11.8		16.6	16.1		
Progression Factor	1.00	1.00		1.00	1.00	1.00	1.00	1.00		1.00	1.00		
Incremental Delay, d <sub>2</sub>	1.0	1.1		2.4	0.3	0.3	0.1	0.2		2.8	0.6		
Delay (s)	25.3	17.1		30.5	18.4	17.1	11.7	12.0		19.4	16.7		
Level of Service	C	B		C	B	B	B	B		B	B		
Approach Delay (s)		18.3			18.6			12.0			17.5		
Approach LOS		B			B			B			B		
<b>Intersection Summary</b>													
HCM Average Control Delay			17.9									HCM Level of Service	B
HCM Volume to Capacity ratio			0.50										
Actuated Cycle Length (s)			60.0									Sum of lost time (s)	12.0
Intersection Capacity Utilization			51.2%									ICU Level of Service	A
Analysis Period (min)			15										
c Critical Lane Group													

HCM Signalized Intersection Capacity Analysis  
58: Williams Field Road & Meridian Road













2035 PM  
2/4/2013

												
Movement	EBL	EBT	EBR	WBL	WBT	WBR	NBL	NBT	NBR	SBL	SBT	SBR
Lane Configurations												
Volume (vph)	502	628	126	74	207	109	130	391	165	235	422	125
Ideal Flow (vphpl)	1900	1900	1900	1900	1900	1900	1900	1900	1900	1900	1900	1900
Total Lost time (s)	4.0	4.0		4.0	4.0		4.0	4.0		4.0	4.0	
Lane Util. Factor	0.97	0.91		0.97	0.91		1.00	0.95		1.00	0.95	
Frt	1.00	0.97		1.00	0.95		1.00	0.96		1.00	0.97	
Flt Protected	0.95	1.00		0.95	1.00		0.95	1.00		0.95	1.00	
Satd. Flow (prot)	3433	4958		3433	4822		1770	3382		1770	3418	
Flt Permitted	0.95	1.00		0.95	1.00		0.40	1.00		0.20	1.00	
Satd. Flow (perm)	3433	4958		3433	4822		737	3382		373	3418	
Peak-hour factor, PHF	0.90	0.90	0.90	0.90	0.90	0.90	0.90	0.90	0.90	0.90	0.90	0.90
Adj. Flow (vph)	558	698	140	82	230	121	144	434	183	261	469	139
RTOR Reduction (vph)	0	51	0	0	100	0	0	72	0	0	40	0
Lane Group Flow (vph)	558	787	0	82	251	0	144	545	0	261	568	0
Turn Type	Prot			Prot			pm+pt			pm+pt		
Protected Phases	7	4		3	8		5	2		1	6	
Permitted Phases							2			6		
Actuated Green, G (s)	11.0	19.2		3.2	11.4		22.1	16.5		30.6	21.0	
Effective Green, g (s)	11.0	19.2		3.2	11.4		22.1	16.5		30.6	21.0	
Actuated g/C Ratio	0.17	0.30		0.05	0.18		0.34	0.25		0.47	0.32	
Clearance Time (s)	4.0	4.0		4.0	4.0		4.0	4.0		4.0	4.0	
Vehicle Extension (s)	3.0	3.0		3.0	3.0		3.0	3.0		3.0	3.0	
Lane Grp Cap (vph)	581	1465		169	846		340	859		393	1104	
v/s Ratio Prot	c0.16	c0.16		0.02	0.05		0.04	0.16		c0.10	0.17	
v/s Ratio Perm							0.11			c0.21		
v/c Ratio	0.96	0.54		0.49	0.30		0.42	0.63		0.66	0.51	
Uniform Delay, d1	26.8	19.2		30.1	23.3		15.4	21.6		12.0	17.9	
Progression Factor	1.00	1.00		1.00	1.00		1.00	1.00		1.00	1.00	
Incremental Delay, d2	27.6	0.4		2.2	0.2		0.9	3.6		4.2	1.7	
Delay (s)	54.4	19.6		32.3	23.5		16.3	25.1		16.2	19.6	
Level of Service	D	B		C	C		B	C		B	B	
Approach Delay (s)		33.5			25.2			23.4			18.6	
Approach LOS		C			C			C			B	
<b>Intersection Summary</b>												
HCM Average Control Delay			26.5			HCM Level of Service				C		
HCM Volume to Capacity ratio			0.66									
Actuated Cycle Length (s)			65.0			Sum of lost time (s)			8.0			
Intersection Capacity Utilization			63.2%			ICU Level of Service				B		
Analysis Period (min)			15									
c Critical Lane Group												

















HCM Signalized Intersection Capacity Analysis  
62: SR 24 WB on-ramp & Meridian Road

2035 PM  
2/4/2013

						
Movement	EBL	EBR	NBL	NBT	SBT	SBR
Lane Configurations			 	 	 	
Volume (vph)	0	0	708	532	742	137
Ideal Flow (vphpl)	1900	1900	1900	1900	1900	1900
Total Lost time (s)			4.0	4.0	4.0	4.0
Lane Util. Factor			0.97	0.95	0.95	1.00
Frt			1.00	1.00	1.00	0.85
Flt Protected			0.95	1.00	1.00	1.00
Satd. Flow (prot)			3433	3539	3539	1583
Flt Permitted			0.10	1.00	1.00	1.00
Satd. Flow (perm)			361	3539	3539	1583
Peak-hour factor, PHF	0.90	0.90	0.90	0.90	0.90	0.90
Adj. Flow (vph)	0	0	787	591	824	152
RTOR Reduction (vph)	0	0	0	0	0	84
Lane Group Flow (vph)	0	0	787	591	824	68
Turn Type			pm+pt			Perm
Protected Phases			2	5 6	6	
Permitted Phases			5 6			6
Actuated Green, G (s)			56.0	60.0	16.0	16.0
Effective Green, g (s)			56.0	60.0	16.0	16.0
Actuated g/C Ratio			0.93	1.00	0.27	0.27
Clearance Time (s)			4.0		4.0	4.0
Lane Grp Cap (vph)			1156	3539	944	422
v/s Ratio Prot			c0.18	0.17	c0.23	
v/s Ratio Perm			c0.45			0.04
v/c Ratio			0.68	0.17	0.87	0.16
Uniform Delay, d1			15.6	0.0	21.0	16.9
Progression Factor			0.88	1.00	1.00	1.00
Incremental Delay, d2			1.1	0.0	11.0	0.8
Delay (s)			14.8	0.0	32.0	17.7
Level of Service			B	A	C	B
Approach Delay (s)	0.0			8.5	29.8	
Approach LOS	A			A	C	
<b>Intersection Summary</b>						
HCM Average Control Delay			17.3		HCM Level of Service	B
HCM Volume to Capacity ratio			0.74			
Actuated Cycle Length (s)			60.0		Sum of lost time (s)	8.0
Intersection Capacity Utilization			62.8%		ICU Level of Service	B
Analysis Period (min)			15			
c Critical Lane Group						

HCM Signalized Intersection Capacity Analysis  
63: SR 24 EB off-ramp & Meridian Road

2035 PM  
2/4/2013

























						
Movement	EBL	EBR	NBL	NBT	SBT	SBR
Lane Configurations		 		  	 	
Volume (vph)	113	1018	0	1241	742	0
Ideal Flow (vphpl)	1900	1900	1900	1900	1900	1900
Total Lost time (s)	4.0	4.0		4.0	4.0	
Lane Util. Factor	1.00	0.88		0.91	0.95	
Flt	1.00	0.85		1.00	1.00	
Flt Protected	0.95	1.00		1.00	1.00	
Satd. Flow (prot)	1770	2787		5085	3539	
Flt Permitted	0.95	1.00		1.00	1.00	
Satd. Flow (perm)	1770	2787		5085	3539	
Peak-hour factor, PHF	0.90	0.90	0.90	0.90	0.90	0.90
Adj. Flow (vph)	126	1131	0	1379	824	0
RTOR Reduction (vph)	0	11	0	0	0	0
Lane Group Flow (vph)	126	1120	0	1379	824	0
Turn Type	Perm					
Protected Phases	4 12			2	2	
Permitted Phases		4 12				
Actuated Green, G (s)	36.0	36.0		16.0	16.0	
Effective Green, g (s)	36.0	36.0		16.0	16.0	
Actuated g/C Ratio	0.60	0.60		0.27	0.27	
Clearance Time (s)				4.0	4.0	
Lane Grp Cap (vph)	1062	1672		1356	944	
v/s Ratio Prot	0.07			c0.27	0.23	
v/s Ratio Perm		c0.40				
v/c Ratio	0.12	0.67		1.02	0.87	
Uniform Delay, d1	5.2	8.0		22.0	21.0	
Progression Factor	1.00	1.00		1.00	0.64	
Incremental Delay, d2	0.2	2.2		28.8	5.5	
Delay (s)	5.4	10.2		50.8	18.9	
Level of Service	A	B		D	B	
Approach Delay (s)	9.7			50.8	18.9	
Approach LOS	A			D	B	

Intersection Summary			
HCM Average Control Delay	28.2	HCM Level of Service	C
HCM Volume to Capacity ratio	0.78		
Actuated Cycle Length (s)	60.0	Sum of lost time (s)	8.0
Intersection Capacity Utilization	62.8%	ICU Level of Service	B
Analysis Period (min)	15		

c Critical Lane Group

HCM Signalized Intersection Capacity Analysis  
60: Pecos Road & Meridian Road

2035 PM  
2/4/2013

												
Movement	EBL	EBT	EBR	WBL	WBT	WBR	NBL	NBT	NBR	SBL	SBT	SBR
Lane Configurations		 			 			 		 	 	
Volume (vph)	64	161	9	25	157	324	46	740	139	232	1400	171
Ideal Flow (vphpl)	1900	1900	1900	1900	1900	1900	1900	1900	1900	1900	1900	1900
Total Lost time (s)	4.0	4.0		4.0	4.0		4.0	4.0		4.0	4.0	
Lane Util. Factor	1.00	0.95		1.00	0.95		1.00	0.95		0.97	0.95	
Fr <sub>t</sub>	1.00	0.99		1.00	0.90		1.00	0.98		1.00	0.98	
Fl <sub>t</sub> Protected	0.95	1.00		0.95	1.00		0.95	1.00		0.95	1.00	
Satd. Flow (prot)	1770	3511		1770	3181		1770	3455		3433	3481	
Fl <sub>t</sub> Permitted	0.31	1.00		0.63	1.00		0.14	1.00		0.95	1.00	
Satd. Flow (perm)	577	3511		1179	3181		266	3455		3433	3481	
Peak-hour factor, PHF	0.90	0.90	0.90	0.90	0.90	0.90	0.90	0.90	0.90	0.90	0.90	0.90
Adj. Flow (vph)	71	179	10	28	174	360	51	822	154	258	1556	190
RTOR Reduction (vph)	0	6	0	0	180	0	0	24	0	0	14	0
Lane Group Flow (vph)	71	183	0	28	354	0	51	952	0	258	1732	0
Turn Type	Perm			Perm			pm+pt			Prot		
Protected Phases		4			8		5	2		1	6	
Permitted Phases	4			8			2					
Actuated Green, G (s)	16.0	16.0		16.0	16.0		32.0	28.0		9.0	33.0	
Effective Green, g (s)	16.0	16.0		16.0	16.0		32.0	28.0		9.0	33.0	
Actuated g/C Ratio	0.25	0.25		0.25	0.25		0.49	0.43		0.14	0.51	
Clearance Time (s)	4.0	4.0		4.0	4.0		4.0	4.0		4.0	4.0	
Lane Grp Cap (vph)	142	864		290	783		224	1488		475	1767	
v/s Ratio Prot		0.05			0.11		0.01	0.28		c0.08	c0.50	
v/s Ratio Perm	c0.12			0.02			0.10					
v/c Ratio	0.50	0.21		0.10	0.45		0.23	0.64		0.54	0.98	
Uniform Delay, d <sub>1</sub>	21.1	19.5		18.9	20.8		13.2	14.5		26.1	15.7	
Progression Factor	1.00	1.00		1.00	1.00		1.00	1.00		1.00	1.00	
Incremental Delay, d <sub>2</sub>	12.0	0.6		0.7	1.9		2.4	2.1		4.4	17.2	
Delay (s)	33.1	20.0		19.6	22.7		15.5	16.7		30.5	32.9	
Level of Service	C	C		B	C		B	B		C	C	
Approach Delay (s)		23.6			22.5			16.6			32.5	
Approach LOS		C			C			B			C	

Intersection Summary



























HCM Average Control Delay	26.2	HCM Level of Service	C
HCM Volume to Capacity ratio	0.82		
Actuated Cycle Length (s)	65.0	Sum of lost time (s)	12.0
Intersection Capacity Utilization	79.2%	ICU Level of Service	D
Analysis Period (min)	15		

c Critical Lane Group

# HCM Signalized Intersection Capacity Analysis

## 50: Germann Road & Meridian Road

2035 PM  
2/4/2013

												
Movement	EBL	EBT	EBR	WBL	WBT	WBR	NBL	NBT	NBR	SBL	SBT	SBR
Lane Configurations		 		 	 			 			 	
Volume (vph)	243	518	24	27	108	403	34	297	10	165	680	104
Ideal Flow (vphpl)	1900	1900	1900	1900	1900	1900	1900	1900	1900	1900	1900	1900
Total Lost time (s)	4.0	4.0		4.0	4.0		4.0	4.0		4.0	4.0	
Lane Util. Factor	1.00	0.95		0.97	0.95		1.00	0.95		1.00	0.95	
Flt	1.00	0.99		1.00	0.88		1.00	1.00		1.00	0.98	
Flt Protected	0.95	1.00		0.95	1.00		0.95	1.00		0.95	1.00	
Satd. Flow (prot)	1770	3515		3433	3120		1770	3522		1770	3469	
Flt Permitted	0.28	1.00		0.95	1.00		0.20	1.00		0.55	1.00	
Satd. Flow (perm)	526	3515		3433	3120		373	3522		1018	3469	
Peak-hour factor, PHF	0.90	0.90	0.90	0.90	0.90	0.90	0.90	0.90	0.90	0.90	0.90	0.90
Adj. Flow (vph)	270	576	27	30	120	448	38	330	11	183	756	116
RTOR Reduction (vph)	0	6	0	0	227	0	0	4	0	0	22	0
Lane Group Flow (vph)	270	597	0	30	341	0	38	337	0	183	850	0
Turn Type	pm+pt			Prot			Perm			Perm		
Protected Phases	7	4		3	8			2				6
Permitted Phases	4						2			6		
Actuated Green, G (s)	26.0	19.0		4.0	16.0		20.0	20.0		20.0	20.0	
Effective Green, g (s)	26.0	19.0		4.0	16.0		20.0	20.0		20.0	20.0	
Actuated g/C Ratio	0.47	0.35		0.07	0.29		0.36	0.36		0.36	0.36	
Clearance Time (s)	4.0	4.0		4.0	4.0		4.0	4.0		4.0	4.0	
Lane Grp Cap (vph)	407	1214		250	908		136	1281		370	1261	
v/s Ratio Prot	c0.08	0.17		0.01	0.11			0.10			c0.24	
v/s Ratio Perm	c0.23						0.10			0.18		
v/c Ratio	0.66	0.49		0.12	0.38		0.28	0.26		0.49	0.67	
Uniform Delay, d1	9.6	14.2		23.9	15.5		12.4	12.3		13.6	14.8	
Progression Factor	1.00	1.00		1.00	1.00		1.00	1.00		1.00	1.00	
Incremental Delay, d2	8.3	1.4		1.0	1.2		5.1	0.5		4.7	2.9	
Delay (s)	17.9	15.6		24.8	16.7		17.4	12.8		18.2	17.6	
Level of Service	B	B		C	B		B	B		B	B	
Approach Delay (s)		16.3			17.1			13.3			17.7	
Approach LOS		B			B			B			B	
<b>Intersection Summary</b>												
HCM Average Control Delay			16.6			HCM Level of Service				B		
HCM Volume to Capacity ratio			0.71									
Actuated Cycle Length (s)			55.0			Sum of lost time (s)			12.0			
Intersection Capacity Utilization			68.3%			ICU Level of Service				C		
Analysis Period (min)			15									

c Critical Lane Group

# APPENDIX C

## ITEMIZED COST ESTIMATES FOR ALIGNMENT ALTERNATIVES

**Baker**

**Michael Baker Jr., Inc.**  
*Phoenix, Arizona*



Itemized Cost Estimate for Meridian Rd Southern Alternatives - Southern Ave to Germann Rd

**Short-Term Recommendation**

ITEM	ITEM DESCRIPTION	UNIT	UNIT PRICE	QUANTITY	TOTAL
-	(SEGMENT LENGTH)	MILES	-	2	-
1	NEW PAVEMENT	SY	32	46934	\$ 1,501,888.00
2	EARTHWORK	LSUM	N/A	25% of Item 1	\$ 375,472.00
3	DRAINAGE	LSUM	N/A	15% of Item 1	\$ 225,283.20
4	STRUCTURES	LSUM	\$ 500,000.00	0	\$ -
5	MAINTENANCE OF TRAFFIC	LSUM	N/A	10% of Items 1-3	\$ 210,264.32
6	LIGHTING	LSUM	N/A	5% of Items 1-3	\$ 105,132.16
7	SIGNING/SIGNALS	LSUM	N/A	15% of Items 1-3	\$ 315,396.48
8	UTILITIES	LSUM	N/A	5% of Items 1-3	\$ 105,132.16
9	INCIDENTAL WORK	LSUM	N/A	15% of Items 1-3	\$ 315,396.48
Total Construction Cost =					\$ 3,153,964.80
10	ROW ACQUISITION	ACRE	\$ 20,000.00	16	\$ 320,000.00
11	DESIGN AND CONSTRUCTION MANAGEMENT	LSUM	N/A	25% of Item 1-10	\$ 868,491.20
12	CONTINGENCY	LSUM	N/A	25% of Item 1-10	\$ 868,491.20
Order of Magnitude Project Cost* =					\$ 5,210,947.20

\* This excludes cost for the US 60 interchange and improvements to Southern Avenue intersection

**Alternative 2 Mid/Long-Term Recommendation**

ITEM	ITEM DESCRIPTION	UNIT	UNIT PRICE	QUANTITY	TOTAL
-	(SEGMENT LENGTH)	MILES	-	7.5	-
1	NEW PAVEMENT	SY	32	228800	\$ 7,321,600.00
2	EARTHWORK	LSUM	N/A	25% of Item 1	\$ 1,830,400.00
3	DRAINAGE	LSUM	N/A	15% of Item 1	\$ 1,098,240.00
4	STRUCTURES	LSUM	\$ 500,000.00	1	\$ 500,000.00
5	MAINTENANCE OF TRAFFIC	LSUM	N/A	10% of Items 1-3	\$ 1,025,024.00
6	LIGHTING	LSUM	N/A	5% of Items 1-3	\$ 512,512.00
7	SIGNING/SIGNALS	LSUM	N/A	15% of Items 1-3	\$ 1,537,536.00
8	UTILITIES	LSUM	N/A	5% of Items 1-3	\$ 512,512.00
9	INCIDENTAL WORK	LSUM	N/A	15% of Items 1-3	\$ 1,537,536.00
Total Construction Cost =					\$ 15,875,360.00
10	ROW ACQUISITION	ACRE	\$ 20,000.00	60	\$ 1,200,000.00
11	DESIGN AND CONSTRUCTION MANAGEMENT	LSUM	N/A	25% of Item 1-10	\$ 4,268,840.00
12	CONTINGENCY	LSUM	N/A	25% of Item 1-10	\$ 4,268,840.00
Order of Magnitude Project Cost =					\$ 25,613,040.00

**Alternative 3 Mid/Long-Term Recommendation**

ITEM	ITEM DESCRIPTION	UNIT	UNIT PRICE	QUANTITY	TOTAL
-	(SEGMENT LENGTH)	MILES	-	7.5	-
1	NEW PAVEMENT	SY	32	228800	\$ 7,321,600.00
2	EARTHWORK	LSUM	N/A	25% of Item 1	\$ 1,830,400.00
3	DRAINAGE	LSUM	N/A	20% of Item 1	\$ 1,464,320.00
4	STRUCTURES	LSUM	\$ 1,000,000.00	1	\$ 1,000,000.00
5	MAINTENANCE OF TRAFFIC	LSUM	N/A	10% of Items 1-3	\$ 1,061,632.00
6	LIGHTING	LSUM	N/A	5% of Items 1-3	\$ 530,816.00
7	SIGNING/SIGNALS	LSUM	N/A	10% of Items 1-3	\$ 1,592,448.00
8	UTILITIES	LSUM	N/A	5% of Items 1-3	\$ 530,816.00
9	INCIDENTAL WORK	LSUM	N/A	15% of Items 1-3	\$ 1,592,448.00
Total Construction Cost =					\$ 16,924,480.00
10	ROW ACQUISITION	ACRE	\$ 20,000.00	119	\$ 2,380,000.00
11	DESIGN AND CONSTRUCTION MANAGEMENT	LSUM	N/A	25% of Item 1-10	\$ 4,826,120.00
12	CONTINGENCY	LSUM	N/A	25% of Item 1-10	\$ 4,826,120.00
Order of Magnitude Project Cost =					\$ 28,956,720.00

Itemized Cost Estimate for Meridian Rd Southern Alternatives - Southern Ave to Germann Rd (continued)

**Alternative 4 Mid/Long-Term Recommendation**

ITEM	ITEM DESCRIPTION	UNIT	UNIT PRICE	QUANTITY	TOTAL
-	(SEGMENT LENGTH)	MILES	-	7.5	-
1	NEW PAVEMENT	SY	32	228800	\$ 7,321,600.00
2	EARTHWORK	LSUM	N/A	25% of Item 1	\$ 1,830,400.00
3	DRAINAGE	LSUM	N/A	15% of Item 1	\$ 1,098,240.00
4	STRUCTURES	LSUM	\$ 500,000.00	1	\$ 500,000.00
5	MAINTENANCE OF TRAFFIC	LSUM	N/A	10% of Items 1-3	\$ 1,025,024.00
6	LIGHTING	LSUM	N/A	5% of Items 1-3	\$ 512,512.00
7	SIGNING/SIGNALS	LSUM	N/A	15% of Items 1-3	\$ 1,537,536.00
8	UTILITIES	LSUM	N/A	5% of Items 1-3	\$ 512,512.00
9	INCIDENTAL WORK	LSUM	N/A	15% of Items 1-3	\$ 1,537,536.00
Total Construction Cost =					\$ 15,875,360.00
10	ROW ACQUISITION	ACRE	\$ 20,000.00	60	\$ 1,200,000.00
11	DESIGN AND CONSTRUCTION MANAGEMENT	LSUM	N/A	25% of Item 1-10	\$ 4,268,840.00
12	CONTINGENCY	LSUM	N/A	25% of Item 1-10	\$ 4,268,840.00
Order of Magnitude Project Cost =					\$ 25,613,040.00

**Alternative 2 Ultimate Recommendation**

ITEM	ITEM DESCRIPTION	UNIT	UNIT PRICE	QUANTITY	TOTAL
-	(SEGMENT LENGTH)	MILES	-	7.5	-
1	NEW PAVEMENT	SY	32	105600	\$ 3,379,200.00
2	EARTHWORK	LSUM	N/A	25% of Item 1	\$ 844,800.00
3	DRAINAGE	LSUM	N/A	15% of Item 1	\$ 506,880.00
4	STRUCTURES	LSUM	\$ 500,000.00	1	\$ 500,000.00
5	MAINTENANCE OF TRAFFIC	LSUM	N/A	10% of Items 1-3	\$ 473,088.00
6	LIGHTING	LSUM	N/A	5% of Items 1-3	\$ 236,544.00
7	SIGNING/SIGNALS	LSUM	N/A	15% of Items 1-3	\$ 709,632.00
8	UTILITIES	LSUM	N/A	5% of Items 1-3	\$ 236,544.00
9	INCIDENTAL WORK	LSUM	N/A	15% of Items 1-3	\$ 709,632.00
Total Construction Cost =					\$ 7,596,320.00
10	ROW ACQUISITION	ACRE	\$ 20,000.00	0	\$ -
11	DESIGN AND CONSTRUCTION MANAGEMENT	LSUM	N/A	25% of Item 1-10	\$ 1,899,080.00
12	CONTINGENCY	LSUM	N/A	25% of Item 1-10	\$ 1,899,080.00
Order of Magnitude Project Cost =					\$ 11,394,480.00

**Alternative 3 Ultimate Recommendation**

ITEM	ITEM DESCRIPTION	UNIT	UNIT PRICE	QUANTITY	TOTAL
-	(SEGMENT LENGTH)	MILES	-	7.5	-
1	NEW PAVEMENT	SY	32	105600	\$ 3,379,200.00
2	EARTHWORK	LSUM	N/A	25% of Item 1	\$ 844,800.00
3	DRAINAGE	LSUM	N/A	20% of Item 1	\$ 675,840.00
4	STRUCTURES	LSUM	\$ 1,000,000.00	1	\$ 1,000,000.00
5	MAINTENANCE OF TRAFFIC	LSUM	N/A	10% of Items 1-3	\$ 489,984.00
6	LIGHTING	LSUM	N/A	5% of Items 1-3	\$ 244,992.00
7	SIGNING/SIGNALS	LSUM	N/A	10% of Items 1-3	\$ 734,976.00
8	UTILITIES	LSUM	N/A	5% of Items 1-3	\$ 244,992.00
9	INCIDENTAL WORK	LSUM	N/A	15% of Items 1-3	\$ 734,976.00
Total Construction Cost =					\$ 8,349,760.00
10	ROW ACQUISITION	ACRE	\$ 20,000.00	0	\$ -
11	DESIGN AND CONSTRUCTION MANAGEMENT	LSUM	N/A	25% of Item 1-10	\$ 2,087,440.00
12	CONTINGENCY	LSUM	N/A	25% of Item 1-10	\$ 2,087,440.00
Order of Magnitude Project Cost =					\$ 12,524,640.00

Itemized Cost Estimate for Meridian Rd Southern Alternatives - Southern Ave to Germann Rd (continued)

**Alternative 4 Ultimate Recommendation**

ITEM	ITEM DESCRIPTION	UNIT	UNIT PRICE	QUANTITY	TOTAL
-	(SEGMENT LENGTH)	MILES	-	7.5	-
1	NEW PAVEMENT	SY	32	105600	\$ 3,379,200.00
2	EARTHWORK	LSUM	N/A	25% of Item 1	\$ 844,800.00
3	DRAINAGE	LSUM	N/A	15% of Item 1	\$ 506,880.00
4	STRUCTURES	LSUM	\$ 500,000.00	1	\$ 500,000.00
5	MAINTENANCE OF TRAFFIC	LSUM	N/A	10% of Items 1-3	\$ 473,088.00
6	LIGHTING	LSUM	N/A	5% of Items 1-3	\$ 236,544.00
7	SIGNING/SIGNALS	LSUM	N/A	15% of Items 1-3	\$ 709,632.00
8	UTILITIES	LSUM	N/A	5% of Items 1-3	\$ 236,544.00
9	INCIDENTAL WORK	LSUM	N/A	15% of Items 1-3	\$ 709,632.00
Total Construction Cost =					\$ 7,596,320.00
10	ROW ACQUISITION	ACRE	\$ 20,000.00	0	\$ -
11	DESIGN AND CONSTRUCTION MANAGEMENT	LSUM	N/A	25% of Item 1-10	\$ 1,899,080.00
12	CONTINGENCY	LSUM	N/A	25% of Item 1-10	\$ 1,899,080.00
Order of Magnitude Project Cost =					\$ 11,394,480.00

Itemized Cost Estimate for Meridian Rd - McDowell Rd to Southern Ave

**Mid-Term Recommendation**

ITEM	ITEM DESCRIPTION	UNIT	UNIT PRICE	QUANTITY	TOTAL
-	(SEGMENT LENGTH)	MILES	-	5.5	-
1	NEW PAVEMENT	SY	32	129067	\$ 4,130,144.00
2	EARTHWORK	LSUM	N/A	5% of Item 1	\$ 206,507.20
3	DRAINAGE	LSUM	N/A	15% of Item 1	\$ 619,521.60
4	STRUCTURES	LSUM	N/A	0	\$ -
5	MAINTENANCE OF TRAFFIC	LSUM	N/A	10% of Items 1-3	\$ 495,617.28
6	LIGHTING	LSUM	N/A	1% of Items 1-3	\$ 49,561.73
7	SIGNING/SIGNALS	LSUM	N/A	10% of Items 1-3	\$ 495,617.28
8	UTILITIES	LSUM	N/A	15% of Items 1-3	\$ 743,425.92
9	INCIDENTAL WORK	LSUM	N/A	15% of Items 1-3	\$ 743,425.92
Total Construction Cost =					\$ 7,483,820.93
10	ROW ACQUISITION	ACRE	\$ 20,000.00	25	\$ 500,000.00
11	DESIGN AND CONSTRUCTION MANAGEMENT	LSUM	N/A	25% of Item 1-10	\$ 1,995,955.23
12	CONTINGENCY	LSUM	N/A	25% of Item 1-10	\$ 1,995,955.23
Order of Magnitude Project Cost =					\$ 11,975,731.39

**Long-Term Recommendation**

ITEM	ITEM DESCRIPTION	UNIT	UNIT PRICE	QUANTITY	TOTAL
-	(SEGMENT LENGTH)	MILES	-	5.5	-
1	NEW PAVEMENT	SY	32	96214	\$ 3,078,848.00
2	EARTHWORK	LSUM	N/A	5% of Item 1	\$ 153,942.40
3	DRAINAGE	LSUM	N/A	15% of Item 1	\$ 461,827.20
4	STRUCTURES	LSUM	N/A	0	\$ -
5	MAINTENANCE OF TRAFFIC	LSUM	N/A	10% of Items 1-3	\$ 369,461.76
6	LIGHTING	LSUM	N/A	1% of Items 1-3	\$ 36,946.18
7	SIGNING/SIGNALS	LSUM	N/A	10% of Items 1-3	\$ 369,461.76
8	UTILITIES	LSUM	N/A	15% of Items 1-3	\$ 554,192.64
9	INCIDENTAL WORK	LSUM	N/A	15% of Items 1-3	\$ 554,192.64
Total Construction Cost =					\$ 5,578,872.58
10	ROW ACQUISITION	ACRE	\$ 20,000.00	0	\$ -
11	DESIGN AND CONSTRUCTION MANAGEMENT	LSUM	N/A	25% of Item 1-10	\$ 1,394,718.14
12	CONTINGENCY	LSUM	N/A	25% of Item 1-10	\$ 1,394,718.14
Order of Magnitude Project Cost =					\$ 8,368,308.86

# APPENDIX C

## MERIDIAN ROAD CORRIDOR STUDY PUBLIC INVOLVEMENT REPORT

**Baker**

**Michael Baker Jr., Inc.**  
*Phoenix, Arizona*

# Meridian Road Corridor Study

## Germann Road to McDowell Boulevard

*A Planning Assistance for Rural Areas Study*

### Public Involvement Report



June 2013



## Table of Contents

Introduction .....	3
Outreach .....	3
Stakeholder Outreach .....	3
Communication Activities .....	5
Outreach Activities.....	7
Phase I Public Involvement .....	7
Phase II Public Involvement .....	20
Appendix .....	23
Communication Log	
May 16, 2013 Sign In Sheets	
Post-Meeting Feedback Submissions	

## **Introduction**

ADOT, through its Multimodal Planning and Communication divisions, collaborated with Pinal County to conduct a transportation study of Meridian Road. The study, which was funded through the Planning Assistance for Rural Areas (PARA) program, focused on Meridian Road from Germann Road to McDowell Boulevard. The principal focus of the study was to address the transportation planning needs identified by the jurisdictions and to develop consensus on facility type, number of lanes and right of way requirements to guide future development of the road.

The study area is generally bounded by Germann Road on the south, McDowell Boulevard on the north, Ironwood Road on the east and Signal Butte Road on the west. Meridian Road is a section line alignment road that is located on the boundary between Pinal and Maricopa counties. Pinal County, Maricopa County, Apache Junction, Queen Creek and Mesa all control portions of Meridian Road.

## **Outreach**

The study began in April 2012 and was completed in June 2013. The public involvement strategy focused on three aspects: stakeholder outreach, communication activities and public outreach activities. A summary of the activities is detailed for each strategy below.

### **STAKEHOLDER OUTREACH**

The Technical Advisory Committee (TAC) was comprised of key agency stakeholders with the expertise to assist in the study's development. Members of the TAC included:

- Pinal County
- City of Apache Junction
- City of Mesa
- Central Arizona Association of Governments
- Federal Highway Administration
- Maricopa Association of Governments
- Maricopa County Department of Transportation
- Flood Control District of Maricopa County
- Town of Queen Creek
- Arizona State Land Department
- Arizona Department of Transportation, Multimodal Planning Division
- Arizona Department of Transportation, Phoenix Engineering District
- Arizona Department of Transportation, Communications and Community Partnerships

TAC meetings were held on May 15, 2012; November 14, 2012; December 12, 2012; and February 26, 2013.

Additionally, the technical team conducted several stakeholder interviews as outlined below.

Date	Agency	Representatives	Meeting Subject
5/4/12	Arizona State Land Department (ASLD)	Michelle Green (ASLD), Charla Glendenning (ADOT)	Review the material we covered at the Meridian Road Corridor Study TAC meeting on 5/16/12
6/26/12	ADOT	J Gurrola (ADOT) Kent Kelso (HDR)	North-South Corridor Study and its possible effect on the region and Meridian Road
7/17/12	Flood Control District of Maricopa County (FCDMC)	Jennifer Pokorski (FCDMC) Hernan Aristizabal (Entellus), Laurie Miller (TM Engineering)	Obtain information about current East-Mesa Area Drainage Master Plan (ADMP) up-date.
7/19/12	ADOT	Don Gorman (ADOT), Steve Wilcox (AECOM), Dave Eberhart (ADOT)	Proposed Meridian Road TI – Learn about Proposed TI DCR and timing of design and construction
7/24/12	ADOT	Carlos Lopez (ADOT), Charla Glendenning (ADOT)	Intercity Passenger Rail Study – Possible locations of rail routes and station locations
8/1/12	FCDMC	Bobbie Ohler, Mike Ramirez, Felicia Terry, Michael Jones, Jeff Riddle, Tom Renkly (FCDMC)	Obtain information regarding the flood control structures adjacent to the Meridian Rd corridor, review possible impacts and ascertain FCDMC requirements
8/16/12	FCDMC and ASLD	Michelle Green (ASLD), Ruben Ojeda (ASLD) Manny Patel (ASLD), Lillian Moodey (ASLD), Adam Sharp (ASLD) Jennifer Pokorski (FCDMC), Hernan Aristizabal (Entellus), Laurie Miller (TM Engineering)	East –Mesa ADMP possible coordination between Meridian Road corridor and location of proposed drainage channels
8/28/12	City of Apache Junction	Giao Pham (Apache Junction)	Discussion on working paper #1, road configuration, right of way preservation, multi modal facilities and future development

Date	Agency	Representatives	Meeting Subject
8/28/12	Pinal County	Doug Hanson (Pinal County), Andy Smith (Pinal County)	Discussion on working paper #1, road configuration, right of way preservation, multi modal facilities and future development
11/13/12	City of Mesa	Ken Hall (Mesa)	Discussion on working paper #1, road configuration, right of way preservation, multi modal facilities and future development
12/12/12	FCDMC and ASLD	Afshin Houraiyan (FCDMC); Hernan Aristizabal (Entellus); Wayne Balmer (Queen Creek); Michelle Green (ASLD); Ken Hall (Mesa); Doug Hansen (Pinal County); Denise Lacey (MCDOT); Laurie Miller, (LTM Engineering); Elise Moore (Pinal County); Tom Narva (TOQC); Ruben Ojeda (ASLD); Tim Oliver (MCDOT); Manny Patel (ASLD); Giao Pham (Apache Junction); Jen Pokorski (FCDMC); Charla Glendening (ADOT MPD)	Coordination between Meridian Road corridor and location of proposed drainage channels, possible combined roadway/channel footprint and future development of state land.
1/29/13	Central Arizona Project	Aaron Ashcroft (CAP), Jim Geisbush (CAP)	Discuss conflict at Meridian Road TI along with CAP requirements and future plans.
3/4/13	City of Apache Junction	Giao Pham (Apache Junction)	Meeting to discuss contents of Memorandum of Understanding
3/4/13	Pinal County	Doug Hanson (Pinal County)	Meeting to discuss Memorandum of Understanding
3/18/13	City of Mesa	Ken Hall, Dan Cleavenger, Alan Sanderson, Al Zubi (all from Mesa)	Meeting to discuss contents of Memorandum of Understanding
4/2/13	Maricopa County Department of Transport	Tim Oliver (MCDOT)	Meeting to discuss contents of Memorandum of Understanding

## COMMUNICATION ACTIVITIES

A project Web page was developed as an information portal. Housed under Multimodal Planning Division's PARA studies and found using an easy URL (www.azdot.gov/Meridian), the team posted project-related materials and updated its content throughout the study. Key content included:

- Project fact sheet
- Project work plan and schedule
- Public involvement plan
- Working Paper #1: Existing and Future Conditions Inventory
- Working Paper #2: Evaluation Criteria and Plan for Improvements
- TAC member list and meeting summaries
- Public engagement opportunities and events

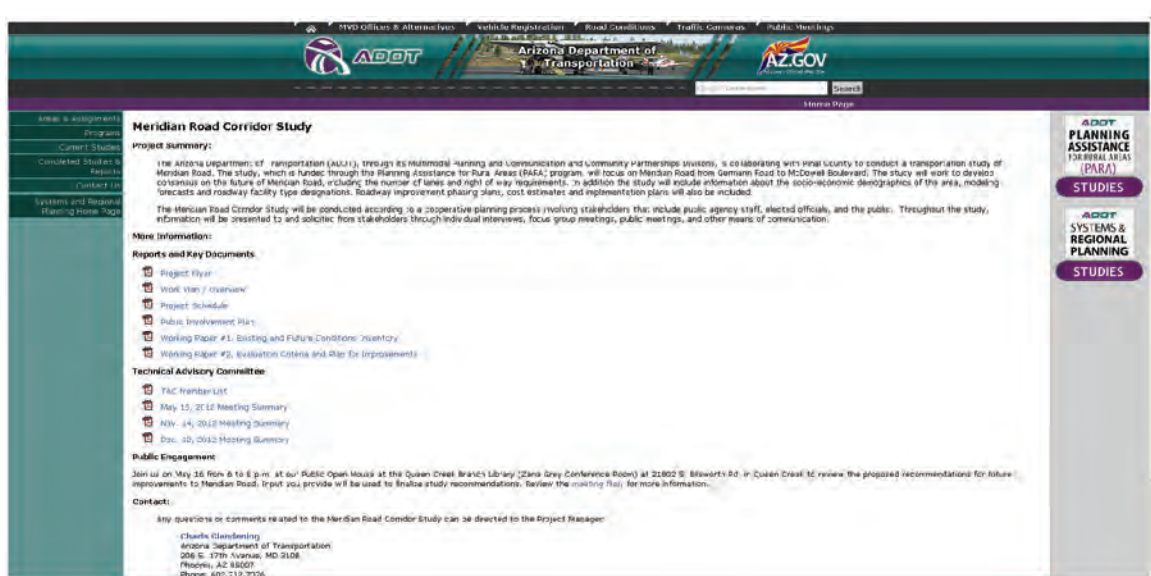

Figure 1: Screen capture of project Web page (May 9, 2013)

Project fact sheets were developed at milestones and were used in conjunction with the public engagement opportunities as mechanisms for advertising the events and soliciting participation. A list of property owners within 300' of the corridor was obtained from Pinal and Maricopa counties. These lists, as well as contacts for HOAs, businesses and other interests adjacent to the corridor, were utilized in soliciting feedback and advertising to the public open house (see "Outreach Activities").



## OUTREACH ACTIVITIES

This section presents the involvement techniques used during the study to support the technical work program.

---

### PHASE I PUBLIC INVOLVEMENT

Phase I of public engagement solicited input on issues and opportunities for the corridor. In addition to stakeholder interviews conducted by the technical team (see “Stakeholder Outreach”), an online survey was utilized to solicit feedback from the public. A total of 43 responses were received via the online survey.

#### *Communication*

In February 2013, fliers were mailed to property owners within 300’ of the corridor inviting them to provide feedback on the study via the online survey. The survey was housed on the project Web page and feedback was solicited from mid-February to mid-April.

#### *Feedback*

*Feedback is provided as it was received and is not edited for grammar or spelling.*

### **1. What opportunities or constraints exist, or what observations do you have, for the Meridian Road corridor between Germann Road and McDowell Boulevard?**

- An interchange is needed at Meridian and Hwy 60 to relieve congestion at the Signal Butte interchange. I would use an interchange at Meridian almost exclusively. I live in Sunland Springs Village just off of Baseline between Signal Butte and Meridian.
- Meridian rd. needs to be four lanes with turning lane from McDowell blvd. to baseline and four lanes from baseline to Germann rd. with enough right of way to accommodate any future expansion needs
- Bike lanes would be very helpful
- Meridian needs to be widened all the way and drainage needs to be established
- I am less familiar with the area above US 60, but this road south of US 60 is heavily residential. A large portion of the road is incomplete on the east side as it is mostly undeveloped land. However just north of Elliott Road the water basin project was done but seems incomplete. Is this area going to be a park or other public use ground? It has almost no trees or plants leaving the area very bare. Meridian itself sometimes floods with heavy rain north of Elliott at Peterson.
- The existing road needs new pavement. Extending the road south from Baseline to Germann would afford alternate route to Queen Creek and beyond.
- Currently a residential area along most of Meridian. I have concerns about noise from increased traffic. Also concerned about access to Meridian from the neighborhoods along Meridian.

- Currently, the only real outlet from Meridian, one must go through Elliot Rd. Either through to Ellsworth, or at least to Signal Butte. Being able to use Meridian to connect to US 60, would be tremendously helpful given all the residential homes in the area. Also having access to get to Baseline and to Main Street/Apache Trail would be very useful and time saving as well.
- There is a lot of hunters that use the state land on the east side of Meridian at around the Warner/Elliot area. Could be a safety concern.
- My house backs to Meridian, concern for future traffic, noise, etc...
- I live just east of Meridian and Pecos Rd. We would love to have Meridian Rd. paved- right now it is a dirt road and we have flooding and impassible roads when it rains. I do not, however, want a 4 or 6 lane highway. We moved out here to be in a rural area. We like our peace and quiet and would not like the noise and traffic that this would bring.
- I can see an improvement in the traffic flow by reducing traffic on Ironwood and Ellsworth. I live between Signal Butte and Ironwood and getting to Queen Creek requires a circuitous route.
- I travel this corridor often and the present road is in very bad condition.
- I live in Sunland Springs Baseline and Signal Butte area, I really don't want the noise, traffic, dust and dirt from construction and the stirring up of snakes, scorpions and coyotes, Hope you don't do it!
- My main concern would be to the value of my home. I live the equivalent of one home away from Meridian and I fear the noise and the proximity to a large/main street will reduce the value of my home.
- It needs to be wider and improved, with sidewalks and bus service.
- Because there is no freeway interchange at Meridian, Meridian Road will never be the busy street it could be.
- My home is backed up against Meridian road. Increasing traffic in this area will create noise pollution, what steps will be taken to ensure this doesn't occur?
- interest as a local property owner near this project area.
- Meridian Road does not 'exist' between Elliot and Baseline. It is a 2 lane road north of Baseline and not that major of a road.
- I am opposed to current proposed corridor between Elliot and Baseline as it will but up to my property in Sunland Springs Village Mesa. There is not sufficient right of way between existing structures in Maricopa county and Pinal Counties for any roadway.
- Needs repaving between superstition and brown. Constraint on front of our property to widen.
- There will be a lot of extra traffic and will make it difficult for several of the residential developments to exit their roads and there are a lot of families that walk the main streets such as Elliott and Meridian as well as there is the State land in that area as well for a lot of the hunting opportunities that will also cause issues for them.

- There are currently no problems with current Meridian Road alignment south of Baseline Road. I do not see that Meridian Road south of Baseline is hindering any current development. The land between US 60 and Elliot, Meridian to Ironwood Roads may not be viewed as favorable to development because of the earth fissure issues. Nor would the land north and east of the Powerline Flood Retention Structure because of flooding.
- I own 5 acres that borders Meridian, just south of Pecos.
- An opportunity that might be possible is the construction of a shopping plaza someplace on Meridian Road, South on the Pinal County side of the line. It would bring in some extra money for the county and possibly put some people to work. I would like a part time job and to just be able to drive down one road to get there would be great. Maybe someplace to put a little park to walk your dog or just sit and relax for a while. That is all I can add for now.
- entrance & exit off 60
- The Meridian Rd. needs much improvement from Baseline north. To extent it south of Baseline would provide an easier route south of the valley.
- The continue loss of open desert
- I believe that there is a need for improved roads in this corridor to reduce future traffic jams.
- I would not like to see access to HWY60 from Meridian.

**2. Do you experience any problems when traveling the corridor? Please specify the kind of problem (such as the location, issue, etc.) and any solutions that might solve the problem.**

- Two lanes on Meridian is not enough. I travel primarily between Baseline and Apache Trail.
- Drainage problems from McDowell to Southern.
- It is difficult to use the road much for local access to shopping centers. Meridian currently ends at the Meridian Pointe Homes. It does not connect to Baseline north of this area.
- The junction at Baseline Road is very poorly lit and Meridian Rd is difficult to find after dark. The intersection at Southern Ave is often very congested. A traffic signal is necessary. Sidewalk adjacent to existing road is necessary.
- The layout of the sidewalk along Meridian between Warner and Elliott is poorly designed and dangerous. It weaves in and out from the street with no buffer zone between the sidewalk and street in many areas. Young children ride bikes and scooters along the sidewalk. I believe there should be a small buffer zone between the sidewalk and the street, even just a few feet. So then if an accident happens on the sidewalk someone would not fall directly on to the street.
- Most of my travels on Meridian are simply from Elliot to the dead end on Meridian.

- Adding this upgrade still leaves an issue with trying to travel east and finding a road that continues through to Ironwood. Anyone that needs to travel east has to use Pecos or Baseline to get to Ironwood. This wouldn't solve the problem and isn't that far from Mountain or Signal Butte, which most people use to access the east now. Would be better use of resources to connect east west vs north south.
- It is difficult with only two ways into the area, via Elliott or Mountain Rd (at Pecos)
- We do not use Meridian road because it is a dirt road. We use our small private paved road up to Pecos. If paving Meridian would mean a big noisy highway then I would rather leave it a dirt road.
- I currently have to travel out of my way to shop and visit Queen Creek - gas is too expensive for those extra miles.
- I have to drive my Motorhome over this road and the roughness is very bad on my coach.
- No!
- I would love to see the development of Signal Butte. I take my children to a charter school in queen creek and the opportunity to use signal be great ( save money{gas}and time)
- The roadway is beat up and in need of replacement, and you cannot use a sidewalk - because they don't have any.
- Don't really have problems with the corridor now that Iroodwood has been improved.
- currently there are not problems but, if the plan is to create extra lanes and more traffic it will be impossible to live in this community with all the noise pollution
- no problems.
- From Baseline north, it could be repaved with better lane markings and turn lanes and shoulders .
- The kind of problem - first and foremost - location. Solution is move corridor to the East away from residential property between Elliot and Baseline.
- Bad pavement. Tearing up our car. Now there is a detour south.
- As of now there is no exit from Elliott to Baseline Rd. this would change that as cause for more congestion and as stated above the difficulties for several developments to exit their limited exits.
- Speed is a problem. People fly up and down this road. Maybe traffic circles or jogs in the road that would force self imposed speed control, or something similar would be good. It would also be good to have access to the freeway, to & from Meridian.
- No problems with the roadway that I frequently travel (south of the transmission lines to Warner).
- There is no good access to my property at this time other than a man made road that goes through washes, etc. and is impossible to traverse when there is rain.

- Problem, yes, by Walgreen's and Safeway, when making the left turn there is not much room in the road for two cars to make the left turn. And at the stop light when crossing main you get a big bump there at the stoplight by Walgreen's which is very hard on the back when you are a passenger. Then the road is rough in spots and I feel it should be coated with blacktop or an extra coat of whatever is used. That is all I have to add for now.
- water drainage between Broadway and Baseline
- We travel mostly from Baseline north to Apache Trail and that portion needs a lot of improvement.
- Currently Meridian at Elliot Road goes only one mile south and and 1/2 north and ends. this section of the road goes nowhere
- Traffic is at times slow and restricted due to too many vehicles.
- my only problem is that the road needs resurfacing.

**3. Do you agree with this recommendation: Meridian Road between Germann Road and Southern Avenue should develop as a 6-lane divided arterial street.**

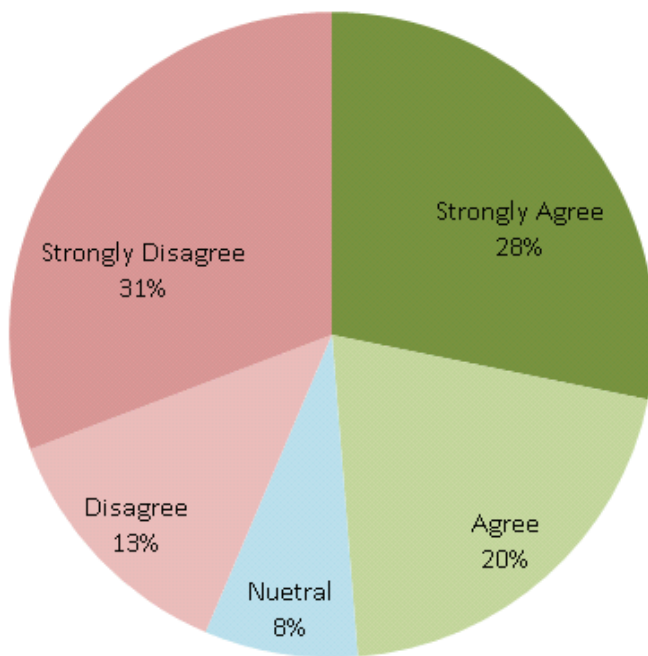

**Comments:**

- Strongly Agree: A painted median should be sufficient
- Strongly Agree: Guadalupe needs to go through to Meridian as planned.
- Strongly Agree: This will be a very heavily traveled road so make it 6 now rather than having to expand it later.
- Strongly Agree: this will prevent a waste of tax dollars do and get it done
- Agree: Need more info as to location Will you have noise barriers, will you cut off our view of The Superstitions??

- N/A: agree
- Neutral: We don't need any more traffic out here in the winter than we already have.
- Disagree: I say disagree, but it depends a lot on what development is planned for the areas east of Meridian. Please remember this area is currently largely residential and a six lane highway while allowing more traffic will increase noise. I had always thought that Ironwood would be the next local six lane highway like Ellsworth. Also I will note that development at Gateway Airport and surrounding area is to the west of Signal Butte. I could see Singal Butte being a six lane highway.
- Disagree: I'd much rather see the 4 lane between Southern and Brown developed here. Going from the area it is now around Elliot, a simply two lane street, which it has been for about 12 years now to a main arterial road would change things far too much both in the form of traffic noise.
- Disagree: Ironwood would be a better choice for that major of a road and has less impact to housing and other developed areas. A two to four lane road should be plenty for Meridian.
- Disagree: With no freeway, US 60, access a 6 lane street seems to be too wide. I believe the majority of traffic will continue to use Signal Butte or Ironwood
- Strongly Disagree: Because of the increased traffic and NOISE Pollution!
- Strongly Disagree: Four lane divided should be sufficient. Because of alignment constrains of the Siphon Draw flood control system, new development in Pinal county should be guided more towards the Ironwood Road Alignment.
- Strongly Disagree: I do not want a 6 lane road next to my house
- Strongly Disagree: It's fine as is.
- Strongly Disagree: no value added to current options for travel north/south. Attention should be for east/west access.
- Strongly Disagree: Recommend two-lane roadway for this stretch.
- Strongly Disagree: The East wall of Sunland Springs Village is just west of the proposed 6 lane "street" you are proposing. The noise associated with a 6 lane street that close to our village will be extremely burdensome and stressful for our residents. Do you have any plans for noise abatement at all in your recommendations?
- Strongly Disagree: the traffic and noise levels will be too high for the residential areas along Meridan



**4. Do you agree with this recommendation: Meridian Road to be a four-lane, divided arterial street between Southern Avenue and Lost Dutchman Boulevard and a two-lane roadway to the north.**

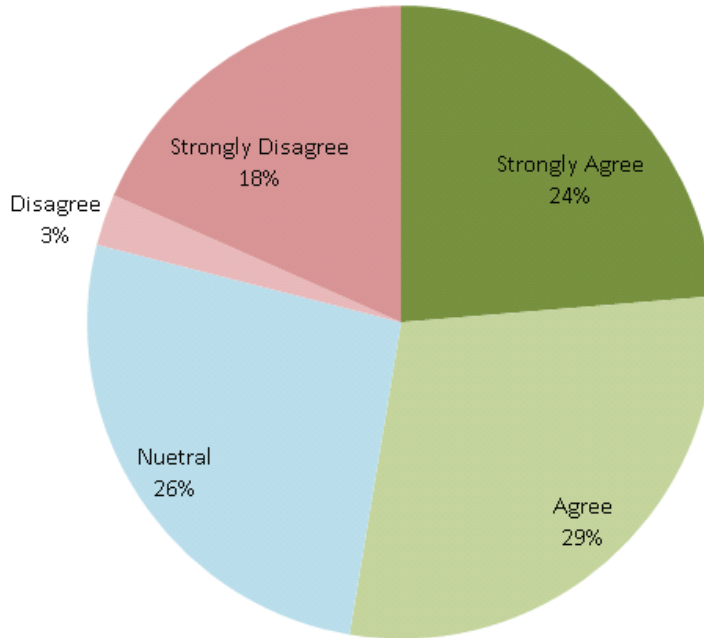

- Strongly Agree: My emphasis is on the "...two-lane roadway to the north." That section of Meridian should incorporate a way to accommodate horses. There are a lot of horse people in that area. And, why not add a planted median (rather than painted) between Lost Dutchman and Southern?
- Agree: Please note comments on previous question [Disagree: I say disagree, but it depends a lot on what development is planned for the areas east of Meridian. Please remember this area is currently largely residential and a six lane highway while allowing more traffic will increase noise. I had always thought that Ironwood would be the next local six lane highway like Ellsworth. Also I will note that development at Gateway Airport and surrounding area is to the west of Signal Butte. I could see Signal Butte being a six lane highway.] However I will add I am less familiar with the area north of US 60
- Agree: Currently do not often use this part of Meridian Road and would not likely use it in the future if it was improved.
- N/A: agree
- N/A: I don't live up there-that is up to the residents that live near that area.
- Neutral: Again we don't need any more traffic out here in the winter than we already have.
- Neutral: That area doesn't affect my home
- Strongly Disagree: It needs to be 6 lanes as well. If it is not, then it is just bad planning and this planning exercise is what it is - worthless!

- Strongly Disagree: It's fine as is.
- Strongly Disagree: Not that much traffic north of University, so leave as a two lane. Just repave it. Four lane ok just to University then two lane north.
- Strongly Disagree: this will makefor a tearing up the road again later to make it 6 lanes later

**5. In your opinion, what opportunities might exist for non-motorized/pedestrian improvements (such as bicycle lanes or sidewalks) along the Meridian Road corridor between Germann Road and McDowell Boulevard?**

- Definitely should have both along the entire corridor.
- Meridian is needing sidewalks especially along the east side of the street. There is now a large water basin along Meridian at Peterson; it would be great if this expansive and already completed area could focus on bicycle paths and open grass areas with plenty of trees for shade - places where people can gather - and desert plants to enhance the areas appeal. I see joggers using the roal often and I would think would use it more often if developed for that use. A lot more trees is a good place to start.
- It would be foolish to create and improve that corridor without providing safe passage for bicyclists and pedestrians
- There should be non-motorized/pedestrian improvements for the corridor. Less pollution and noise.
- Bike lanes are needed
- Currently there are areas without sidewalks south of Warner. Also, the area on the east of Meridian will never be developed. No parks can be added or community benefits.
- I would be open to a paved road with bike lanes.
- I'm an avid bicycle rider and would love more paved riding lanes. Sidewalks would encourage walkers by providing a safe place to walk.
- No opinion.
- none
- I do not find any new opportunities in my neighborhood for non-motorized/pedestrian improvements but find it to be a hindrance. I, along with my children ride bikes and walk our dogs down the sidewalks on Meridian between Elliot and mesquite and I would no longer feel safe enough to do this if Meridian is made a busy large street. Again, another value lost for my home.
- The entire corridor needs to be a "Complete Street" and cater to all modes of traffic, and provide access to "people" of all ages and abilities. Otherwise it will be a failed roadway project giving priorities to cars and not people.
- Marked bike lanes and the normal sidewalks
- None. We are currently able to use non-motorized/pedestrian things in the area.
- bicycle lanes would be good for the numerous bicyclists.
- I think a pedestrian/bike path (like along the Indian Bend wash next to Hayden Rd) with landscaping between the road and the housing developments would be a good idea.

- as previously stated am opposed to any improvements that will border current residential property,
- None, it is rural land.
- In the residential areas there needs to be a safe place for families to ride bikes and go for the walks, now there is some areas with the state land by Elliott that allows for hunting opportunities and it also allows for families to explore the desert without having to travel distances.
- Horse trails/access and horse gates in areas where applicable.
- Pedestrian sidewalks and bicycles lane might enhance the proposed "street".
- Currently I do see that pedestrian traffic uses the current sidewalks along Meridian Pointe and Mountain Heights. The current non-residential development along the alignment north of Baseline Road would does not make it attractive to pedestrian or bicycle traffic.
- I think that it would add greatly to the aesthetics and usage. More and more residents are taking up biking and other outdoor activities that would be enhanced by these features.
- We could use more room to walk and ride your bikes out here. We don't have a good route for bike riders.
- We think it would be a good addition to have bicycle lanes.
- With the open desert I think this is a great opportunity to incorporate bike and walking paths into the project.
- There definitely needs to be bike lanes for bicyclists to be able to travel safely along the corridor.

**6. How might you or your family utilize non-motorized/pedestrian improvements (such as bicycle lanes or sidewalks) along the Meridian Road corridor between Germann Road and McDowell Boulevard?**

- My family would use both pedestrian walkways and bicycle lanes for exercise.
- we would not be utilizing it at all
- As noted above the local area on Meridian could be a gathering point for bicycling, fitness, walkers, joggers, and our kids. I think its important not to have the road to large to deter this kind of use. I personally walk my dog locally and would use it more often if shady open spaces were available. All that being said I understand the need for development and access.
- Recreational use
- we would bike ride and walk more often without having to worry about motorized vehicles
- Could you bicycle lanes for exercise or transportation to areas along corridor.
- If a four lane road was present between Elliot and Baseline, I could see walking / biking up to the shopping areas. If this were a six lane road, I would not even bother.
- We are getting older, and timing of the future is????

- I walk this area and ride my bike a lot. No benefits to anything different. Would honestly become a truck throughfare from the recycling and industry. Also new home construction trucks that use Signal Butte and Mountain would use this.
- If there were a bike lane we might use it but not on a 6 lane highway-way too dangerous.
- We would definitely ride our bicycles and walk those areas if it was safe.
- Will not use them.
- would not, too busy a road to bike on and dangerous for bikes and walkers
- We would not- too busy of a street if made larger with more car traffic. No longer safe for my children to use.
- Through walking and biking, and taking a bus.
- Probably would never use them.
- We have not problem using those items now
- no because we are elderly.
- My family may use the path from Baseline to Guadalupe or Elliot to either bike or walk along.
- Will not utilize.
- Won't use. We're out to far in rural horse country to utilize bicycle or sidewalk. Too far to town.
- I have previously stated the importance of this in all of the previous questions as it is of high importance as well as the safety of being able to enter and exit the residential areas due to extra traffic flow.
- We would use sidewalks, bike lanes and horse trails.
- We have no plans or need to use those...
- I do not think that these improvements would be used much by our family.
- Not sure if we would us them personally, but if this is developed per these plans we might actually move to that area and if so would use the bike lanes, etc.
- There are some of us who walk our dogs daily 3-4 times or more and would use the sidewalks to walk on. There also should be waste baskets along the pathway for the bags when we pick up after our dogs, and a sign stating for people to pick up after their dogs. Now that seems to be a plan to look into.
- My family and I walk and/or ride bikes almost every evening. Additional traffic would dimish that experience but bike and walking trails on the east side of Meridian would be great.
- We probably will not utilize non-motorized/pedestrian improvements.

**7. Do you have any suggestions or ideas related to the long-range plans for Meridian Road between Germann Road and McDowell Boulevard?**

- No
- I have stated through-out this questionnaire that the development of the new water basin on Meridian at Peterson could be developed a large open space and park for the growing area. With the potential of Superstition Vistas to the east there is a unique opportunity for a large open area for all the surrounding communities. The seniors in the area would use these type of spaces if available closer to home. I could easily see Elliott extending to Ironwood and Ironwood providing access to US 60 and points east.
- sooner the better
- Your plan is great! I hope you're able to implement it in my lifetime!
- The area is mostly residential and large arterial roads are not needed. Large arterial roads are needed closer to Ellsworth Rd and Loop 202 to facilitate transportation to and from Williams-Gateway Airport and the surrounding businesses.
- There is a 1 mile stretch that will effect us greatly What plans do you have to protect property values, noise , view, etc between Baseline and Elliot?
- Not value added, as stated previously. If the road doesn't access a main route east, you still backtrack to Ellsworth or connect to the future freeway.
- If you want this then buy my house so I can move away from the area.
- No.
- Complete soon as possible.
- Leave it alone
- I still believe that if the improvements are made to Signal Butte -where people are already prepared for a larger street- is the better bet. What will happen to Crismon Rd.? This would be yet another main thoroughfare that should be examined.
- Make it a complete street, not a highway.
- Not really
- Would not like to see the road in my back yard. As mentioned this will tremendously increase noise pollution. What steps will be taken to remove the noise pollution. The quiet area of this community was the reason I purchased this home.
- no immediate access to freeway currently exists.
- As I stated earlier, I think that Ironwood should be the major corridor, not Meridian, and it could be done ahead of development that will spring up along Ironwood. Less impact to existing developments. I think a four lane road is sufficient for Meridian.
- Move it east!
- Resurface the road to make it smoother.
- main concerns extra traffic and safety due to the added traffic and the families sfety within the residential locations due to the area past Elliott has been a dead end for so long that the traffic has not been too congested but due to the raod improvement this is going to make a large difference to the traffic flows. For the Residential south of Elliot trying to go west is going to be difficult and again there is limited access in or out of these residential areas. There will need to be lights added to Meridian as well due to the added flows.

- Since there will be a significant amount of added traffic coming from Meridian, south of US 60, freeway access becomes much more important. This would relieve congestion at intersections north/south and east/west of US 60 & Meridian Rd.
- There needs to be some kind of noise barrier between the road and the East wall of Sunland Springs Village!!!
- As mentioned before, traffic from future development in Pinal County should be directed more towards the Ironwood Road corridor. There is currently no need for development of Meridian Road south of baseline. Traffic is only light use from the neighborhoods south of the powerline. Improvements to Ironwood and Signal Butte to serve regional traffic would be preferred.
- Get it done asap!
- If there are side walks put along the road way maybe a bench or two here and there wouldn't hurt. And like I mentioned a waste basket for the trash, and some trees here and there like some other areas of AZ.
- The speed limit from Baseline to Germann could be 55 mph.
- Preserve as much of the open desert as possible
- Let's get it done now, ASAP.

**8. Do you have any other feedback regarding the Meridian Road Corridor Study?**

- At present I do not use Meridian very much, but will when it is improved and has an interchange at Hwy 60.
- just make sure there is enough right of way to accommodate future expansion when needed
- I hope the usual practice of providing plants and trees along our newly constructed roads continues even in these somewhat rural areas; the area will not remain rural much longer and beautification of our streets will attract home buyers and businesses as a pleasing area to live and to work. Lastly I will say please think about keeping the set-backs from the roads as wide as possible. I think this helps with noise especially if trees are planted as well. some areas I have seen in Valencia California did this and it appeared to me to encourage community.
- get it done
- Asked and answered
- I live along Meridian. I want to know if there has been an impact study done regarding an affect on property values due to increased noise and traffic.
- A lot of residential areas are along Meridian Rd and the use of a six lane road would have too much noise, pollution, and light issues for the residential areas.
- Get Sunland Springs and Farnsworth involved!
- Previously stated.
- I hope to attend a meeting to hear more.
- No.
- No.



- Please don't do it, leave the land alone in SSV we have enough wild life, snakes and critters don't stir up more for us and we don't need valley fever from all the dust and dirt.
- Listen to your comments and give them honest consideration.
- No
- Yes! Do not put the road in my back yard
- no stop lights on Brown Road or any cross-roads. How long before this project starts?
- No, but thanks for allowing me to provide some feedback.
- Strongly opposed to project!
- How do you plan to acquire our land and will our property taxes be affected.
- In all that is considered please keep safety of all in mind not just 1 area.
- Who is paying for all of this? (The improvement, not the study.)
- No...
- This is well over due as the access to the freeway from this area is horrible and overly congested. I think that it should be extended even further south.
- We should have more police. I only see one in each car, I think there should be two policemen in a car for the simple reason one is not enough. One may need help before backup can get there. That little walkway area would be a nice beat for the police to patrol in the evenings.
- None.

**9. How often do you travel by vehicle on Meridian Road between Germann Road and McDowell Boulevard?**

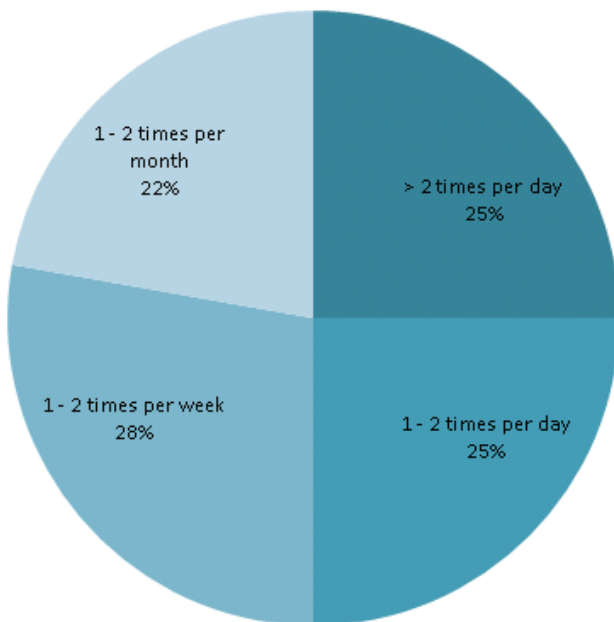

**10. Do you:**

- Live... (6)
- Work... (2)
- Own property... (5)

...along Meridian Road between McDowell Boulevard and US 60.

- 
- Live... (18)
  - Work... (2)
  - Own property... (14)

...along Meridian Road between US 60 and Germann Road.



---

**PHASE II PUBLIC INVOLVEMENT**

Phase II of public engagement solicited feedback on proposed improvements to Meridian Road via a public open house on May 16, 2013 held at the Queen Creek Branch Library. Participants reviewed displays of the proposed alignment, roadway configurations, and current and future levels of service, and discussed the project with project staff and consultants. A total of 37 signed in at registration.

***Communication***

In advance of the public open house, ADOT issued a press release on May 14, 2013 announcing the public open house; published an ad in zones 12 and 15 of the Arizona Republic's community sections on May 1, 2013; and mailed post card invitations to property owners within 300' of the corridor. On May 2, 2013, meeting fliers were distributed to businesses, religious institutions and mobile home/RV parks adjacent to the corridor; for business and entities not open or accessible (i.e. gated communities),

the meeting flier was mailed and/or emailed to organizational contact(s). Finally, public information officers from key project stakeholders (including those jurisdictions that control portions of Meridian Road) were asked to post the meeting flier on their organizational websites and social media outlets, and/or otherwise communicate the public open house.

### **Feedback**

*Feedback is provided as it was received and is not edited for grammar or spelling.*

- If Meridian was brought straight down to about Elliot would work better. There is a two lane road down through the industrial area at this location.
- It would make more sense to go straight south past Baseline through the industrial area to Guadalupe then make your jog. You would not have to buy property since there is a road there already. You also wouldn't have to cross the new cement water way or buy commercial property.
- Suggest that jog be moved further south to the east of drainage in the area between Baseline and Elliot Rd. Or better yet remove the jog altogether and take the road east of the drainage canal. This would minimize impact on current tax base and still provide for future growth.
- Instead of making the realignment of Meridian Rd at Baseline extend in straight south, through the small industrial area that has an existing road through it. Then make the realignment jog at Guadalupe or Elliot. My concern is that when the proposed highway is built it will be 19 to 29 feet from the East wall of the Sunland Springs Residential development. That is too close for the anticipated volume of Traffic for a 4 to 6 lane highway.
- Rather than Meridian Road dog-legging between the 60 & Baseline, recommend Meridian Rd go straight south through the industrial area & dog-leg over between Guadalupe & Elliott. If they go straight through next to the wall that butts up next to Sunland Springs Village as currently planned, it would create too much traffic too close to the subdivision. Also, this will prevent the retention basin from having to be moved.
- I would like more specifications on How this will affect each Homeowner, still have us guessing. Somewhat. SMCFD #1 (sewer) Will City ever take over? Will there be a change
- I am opposed to the four lane road. I live at 14216 S. Meridian Rd. I have been dealing with the county now for three years about the sheet flow and drainage on and around my property. Call me if you would like to discuss.
- 1. How many feet from the East Wall of Sunland Springs Village will the new extension of Meridian be?
  2. Are there any plans for a noise abatement barrier between Meridian and our village?

***Title VI Documentation***

ADOT provided related Title VI items for this public meeting, including display of the informational poster and brochures.

## **Appendix**

### **COMMUNICATION LOG**

#### **MAY 16, 2013 SIGN IN SHEETS**

#### **POST-MEETING FEEDBACK SUBMISSIONS**

May 18, 2013 Letter: Alan and Joy Rash

May 28, 2013 Email: Donald A. and Marlys M. Enger

Date	By way of	Name	Agency/Org	Contact Info	Correspondence	Comments
2/25/13	Email to ADOT Communications	Terri DeBow		<a href="mailto:Casaflores6@yahoo.com">Casaflores6@yahoo.com</a> 480-313-7471	<i>Why is this the first public notice I have recd? Its in my backyard! Why is proposed E/W Freeway south of elliot and north of pecos not shown on study map? This is a large area to study, too large to focus on 2 parts; north of 60 fwy occupied. south of 60 fwy very rural. Not the same type of areas. I can speak of s/o 60 fwy is rural and I wish it to stay that way. The email link on this mailer so how do you expect to get the proper feedback?</i>	Email response sent by Lars Jacoby on 2/26/13
2/27/13	Phone call to Lars Jacoby	Craig Ahlstrom	Sunland Springs	<a href="mailto:craig.ahlstrom@sunlandsprings.com">craig.ahlstrom@sunlandsprings.com</a> 480-984-4999	Study information	Several hundred resident development at Baseline/Meridian; may want to visit HOA later in study
2/27/13	Email to Charla Glendening	Bert Fellows		<a href="mailto:bertjan@cox.net">bertjan@cox.net</a> 480-380-1738	Difficulty in accessing online survey	Email and phone response on 3/5/13 by Audra Koester Thomas
3/4/13	Phone call to Lars Jacoby	Fred Swan			Questions on potential impacts of improvements to property	Phone response on 3/4/13 by Lars Jacoby
3/5/13	Email to Charla Glendening	Barry Walling		<a href="mailto:bwalling@cox.net">bwalling@cox.net</a>	<i>This is a must from 60 south</i>	Email response sent by Charla Glendening on 3/5/13
3/6/13	Email to Lars Jacoby (previous phone call)	Fred Swan		2737 S. Copperwood Mesa, AZ 85209 317-501-0214 <a href="mailto:ltswan@att.net">ltswan@att.net</a>	Concerns that future improvements would reduce property value	Email response sent on 3/8/13 by Lars Jacoby



Meridian Road Corridor Improvement Study



Date	By way of	Name	Agency/Org	Contact Info	Correspondence	Comments
3/25/13	Email to Charla Glendening	Mark Reeb	The Reeb Group, Ltd.	2812 N. Norwalk St., Ste. 105 Mesa, AZ 85215 (480) 898-9090 Office <a href="mailto:markreeb@reebgroup.com">markreeb@reebgroup.com</a>	<i>We own approximately ¼ mile of frontage on Meridian Rd. north of Pecos Rd. in Mesa. We would very much appreciate being informed of the progress of the planning project and receiving the final report when completed.</i>	Email response sent on 3/25/13 by Charla Glendening
5/2/13	Phone call to Lars Jacoby	Jerry		480-577-6807	Questions on project timeline	Phone response by Audra Koester Thomas on 5/3/13
5/2/13	Phone call to Lars Jacoby	Fae VanBuren		480-357-8134	Questions on project timeline and alignment at Baseline Road	Phone response by Audra Koester Thomas on 5/6/13

Date	By way of	Name	Agency/Org	Contact Info	Correspondence	Comments
5/6/13	Meeting with Charla Glendening, Lars Jacoby	Klaus Wolters	PM Industrial Holdings	krwolters@planet.nl	<p><b>Summary</b></p> <ol style="list-style-type: none"> <li>PM Industrial Holdings is owner of about 104 acres along Meridian Road. About 10 acres have been sold recently and roughly 93 acres are left with only access from Meridian Road, at this time a so called 'dirt road in the desert'.</li> <li>For possibilities to sell these 93 acres, for us it,s important to know what the planning is for future construction of this part of Meridian Road.</li> </ol> <p><b>Meeting details</b></p> <ol style="list-style-type: none"> <li>The 'Meridian Road Corridor Study' will be finished in June 2013. ADOT has the ambition to come to a Memorandum of Understanding (MoU) with all stakeholders of this Study. This Study will have no formal status but it will only be a guide for local agencies, future developers along this corridor.</li> <li>The Meridian Road (about 13 Miles) is proposed to be a 6-lane road in future south of US 60 and will be constructed in phases. The construction of the road between Williams Field Road and Pecos Road (that is the part where our land is situated) will not be constructed before 2028 because there is no priority for that. <b>By 2025 the Meridian Road Corridor Study is recommending an interim road of 4 lanes.</b> New road construction in developing areas is driven by, and often funded by, development of the adjacent land. Planning studies provide a guide to anticipate future development needs and timelines. However, in a dynamically developing area like this one cannot predict with certainty when infrastructure might be constructed or who might construct it.</li> <li>The most recent Transportation Plan for the City of Mesa was completed in 2002 : 'Mesa Transportation Plan 2002' (June 24). In this since 2002 leading document, the construction of PM part of Meridian Road was in the 'no funding' period phase 5 (recommended within 21 till 25 years(2023-2027); <b>In Meas's Transporation Plan Meridian Road was classified as a Priority 5 roadway (low priority/long rang) project at that time with improvements scheduled for 2020- 2025. However, in order to fund the Light Rail Extension from Mesa Drive to Gilbert Road, Meridian Road was dropped from the MAG's Arterial Life Cycle Program (ALCP) because the rate of growth was significantly less than predicted.</b></li> <li>Meridian Road is historically strongly involved by flooding problems from east side (Pinal County) , especially the deep washes E 11, 12, 13, 14 and 14N (enclosure) in the area of our property have huge impact on land and unprotected homes west of Meridian Road.</li> <li>To protect in future the new constructed Meridian Road and the property on west side of Meridian Road, a Flooding Channel will be constructed adjacent to Meridian Road on east side. This Flooding Channel will lead the water north of proposed SR 24 in west direction to Ellsworth Road through a Flooding Channel adjacent to SR 24. The storm water south of proposed SR 24 will be lead probably on north south side of Pecos Road in west direction. For that reason there will be constructed a basin on CMC Steel property on SE corner of Pecos Road/Meridian Road, east of existing 'diversion dyke'. <b>These are only conceptual designs and nothing has been finalized.</b> The Flood Control District of Maricopa County is planning for these regional flood control facilities. Mr. Wolters should visit with FCDMC to be certain of the most current plans of the District.</li> <li>The Flooding Channel adjacent to Meridian Road will be constructed at same time as Meridian Road and that is not before 2028. Untill that time, all landowners have to protect their property against stormwater on their own account. <b>There is no programe for the construction of the flood control channel at this time.</b> Ideally the channel and road construction will be coincident but the funding and partnerships to make that happen do not exist today. The project development for each may follow different timelines. What is certain is that construction of either is not in the 5-year construction programs for any of the agencies.</li> </ol>	Meeting summary detailed in "Correspondence"

Date	By way of	Name	Agency/Org	Contact Info	Correspondence	Comments
5/16/13	Public meeting	Paul Leber		11533 E Medina Ave. Mesa 85209-1428 rebeljr@juno.com	<ol style="list-style-type: none"> <li>1. <i>How many feet from the East Wall of Sunland Springs Village will the new extension of Meridian be?</i></li> <li>2. <i>Are there any plans for a noise abatement barrier between Meridian and our village?</i></li> </ol>	<ol style="list-style-type: none"> <li>1. The western edge of the roadway will be approximately 14 feet from the boundary wall.</li> <li>2. Because of the preliminary nature of this project, noise barriers have not been considered at this time. However, during final design, assessment for environmental considerations, such as noise, would be made at that time.</li> </ol> <p>Response sent by Lars Jacoby via email on June 10, 2013</p>

Date	By way of	Name	Agency/Org	Contact Info	Correspondence	Comments
5/28/13	Email	Donald A. Marlys M. Enger		2259 S. Copperwood Mesa, AZ 85209 612-998-8470 952-835-0748 facilitiesmanagement@live.com	<p>We were unable to attend the presentation on May 16, 2013, however we have reviewed the printed materials regarding proposed recommendations for future improvements to Meridian Road.</p> <p>1. Setbacks: The setback from the Farnsworth property line to the 'right of way' line indicate 13' for sidewalk &amp; tree lane. The diagram does not indicate where the current waterway will be placed. This waterway contains water most of the winter months and provides drainage to the lots along the proposed roadway.</p> <p>We propose the Planner/Engineer retain the open waterway at the Maricopa/Pinal county line providing a greater "buffer" between the traffic lanes and the residential zoning with a minimum of 30' green/natural planted space to buffer the highway activity to provide safety and security for the single family residential homes between Copperwood &amp; Meridian Rd.</p> <p>2. Zoning/Use Permits: The 2012 online Report indicates the "Zoned Use" contiguous with Meridian, between Baseline &amp; Elliot Rd is planned as "multi-family residential". We recommend NO further "industrial zoning" permits be issued within the Meridian corridor for property contiguous with existing "residential use" zoning.</p> <p>3. Speed Limit - What is the proposed speed limit on this roadway between Elliot and Baseline Rd?</p>	Included in Phase II comments in public involvement report; waterway comment forwarded to FCDMC; land use comment forwarded to municipalities and counties; response to potential speed limit sent by Lars Jacoby on May 28, 2013



# MERIDIAN ROAD CORRIDOR STUDY PUBLIC OPEN HOUSE

THURSDAY, MAY 16, 2013 · 6 TO 8 P.M. MST · QUEEN CREEK BRANCH LIBRARY · QUEEN CREEK, AZ 85242

Completion of this sign-in sheet is completely voluntary and helps the project team keep an accurate record of meeting attendees. Under state law, any identifying information provided below will become part of the public record and, as such, must be released to any individual upon request. Please print clearly.

NAME	ADDRESS	PHONE	EMAIL
LEON; DONNA BROWNLEE	11526 E NATAL AVE MESA, AZ 85209	480. 706. 1014	LC.BROWNLEE@AOL.COM
Paul Lisen	11533 E MEDINA AVE MESA 85209	480 231-8818	rebeljr@juno.com
DEAN DIEREN	2607 SO. COPPERWOOD MESA 85209	480-380-7410	DEANFDIEREN@GMAIL.COM
Edmund Cohen	871 E Birchwood chandler AZ	602-757-6929	RLD@AZefeb.com
Bob & Diana Grubb	2757 Copperwood West 85209	410-418-4428	stampgranna@yahoo.com
Alan Jackson	19490 E. Silver Creek Q.C. 85147	480-280-5876	alan.jackson@cmi.com
Barry LaNier	11523 E. Quicde Ave MESA 85212	480 529 -1398	BALANIER54@MSN.COM
Manuel & Rebecca Campa	651 S. MERIDIAN RD AJ	480 255 3640	Becky Reyna 55@gmail.com
Jean Bennett	3749 S. Adelle, Mesa	480-532-7011	Jean72253@yahoo.com
Susan Frabotta	PO Box 1466 20 E Main 85211- 1466	480 644 5432	Susan.frabotta@ MesaAZ.GOV





# MERIDIAN ROAD CORRIDOR STUDY PUBLIC OPEN HOUSE

THURSDAY, MAY 16, 2013 · 6 TO 8 P.M. MST · QUEEN CREEK BRANCH LIBRARY · QUEEN CREEK, AZ 85242

Completion of this sign-in sheet is completely voluntary and helps the project team keep an accurate record of meeting attendees. Under state law, any identifying information provided below will become part of the public record and, as such, must be released to any individual upon request. Please print clearly.

NAME	ADDRESS	PHONE	EMAIL
Hamilton, Brian	15017 S. 231 <sup>st</sup> Way	480-988-5314	abbaiiantg@yahoo.com





# MERIDIAN ROAD CORRIDOR STUDY PUBLIC OPEN HOUSE

THURSDAY, MAY 16, 2013 · 6 TO 8 P.M. MST · QUEEN CREEK BRANCH LIBRARY · QUEEN CREEK, AZ 85242

Completion of this sign-in sheet is completely voluntary and helps the project team keep an accurate record of meeting attendees. Under state law, any identifying information provided below will become part of the public record and, as such, must be released to any individual upon request. Please print clearly.

*M*

NAME	ADDRESS	PHONE	EMAIL
Jen Pokorski	FCD		jmp@mail.maricopa.gov
GIAO PHAM	APACHE JCT.		GPHAM@AJCITY.NET
Clark & Mary Smith	Mesa		
DWIGHT VANDEVENTER	MESA 2331 S. COPPERWOOD	480-986-5263	
Doug Hansen	Pinal County		
John Berger	11548 E Madero av	480 380-1011	JL.Berger@cox.net
Howard Day	3290 W. Edge St.	602-757-6927	howard @ azeFad.com a2Efab.com
AMERICAN LEGION POST 27	1018 S MERIDIAN	480-338-2222	
JERRY BARRON	15119 231 WAY ST	480-832-3292	LAKe Bud @ msu.com ✓
Bruno Degiorgi	9050 E. McDowell Rd Mesa AZ 85207	480-354-7579	brunodegiorgi@yahoo.com





# MERIDIAN ROAD CORRIDOR STUDY PUBLIC OPEN HOUSE

THURSDAY, MAY 16, 2013 · 6 TO 8 P.M. MST · QUEEN CREEK BRANCH LIBRARY · QUEEN CREEK, AZ 85242

Completion of this sign-in sheet is completely voluntary and helps the project team keep an accurate record of meeting attendees. Under state law, any identifying information provided below will become part of the public record and, as such, must be released to any individual upon request. Please print clearly.

NAME	ADDRESS	PHONE	EMAIL
Ron Rose	14216 S. Meridian RD	480-228-2096	rmark.rose@netzero.net
DAVID JARVIS	2251 N. 32 <sup>nd</sup> ST. Mesa #30	602.370.5525	djarvis51@hotmail.com
Ann Bicknese	11250 #250 E Kittling Ave Mesa 85209	480 452 3520	sbicknese@cox.net
Elmer Schaufelberger	11330 E. McLaughlin	480 354 5428	
Michael Harambasik	3141 S. SHERRA	480.983-6787	basicdrilling@yahoo.com
PATTY PAULSON	MCDOT	602 506-4897	patty.paulson@mail.maricopa.gov
NARIMAN ZADEH	MCDOT	602-506-8623	narimanzadeham@mail.maricopa.gov





# MERIDIAN ROAD CORRIDOR STUDY PUBLIC OPEN HOUSE

THURSDAY, MAY 16, 2013 · 6 TO 8 P.M. MST · QUEEN CREEK BRANCH LIBRARY · QUEEN CREEK, AZ 85242

Completion of this sign-in sheet is completely voluntary and helps the project team keep an accurate record of meeting attendees. Under state law, any identifying information provided below will become part of the public record and, as such, must be released to any individual upon request. Please print clearly.

NAME	ADDRESS	PHONE	EMAIL
JYL SIMMONS	4343 S. ADOLLE	928-537-7574	hitro175@gmail.com
RANDY SIMMONS	"	"	"
JEPPE DECKER	2233 S. SPRINGWOOD BLVD MESA AZ 85209	480-984-4999	decker@santlandspings.com
David Lehring <small>For → Fred Swan</small>	4737 S. Copperwood	317-501-0214	Ltswan@att.net
Tim Blaylock	3851 S. <del>ADOLLE</del> ADOLLE 85212	480 964-8210	TALIK2VS8@JUNO.COM



May 18, 2013

Alan and Joy Rash  
2307 S. Copperwood  
Mesa, AZ 85209  
480-654-2324  
alan.rash@cox.net

Lars Jacoby  
Community Relations Project Manager  
1655 W. Jackson St.  
Mail Drop: 126F  
Phoenix, AZ 85007

Re: Meridian Road Corridor Study

Mr. Jacoby:

We own a home at 2307 S. Copperwood, Mesa, AZ 85209, in the Sunland Springs Village community. The house is located along the East side of the community next to the perimeter wall. As we understand the proposal, Meridian Road would be built directly adjacent to and parallel with such wall and consequently within a few yards of the rear of our house, as well as that of other similarly located houses.

The existing part of Meridian Road to the North of Highway 60 crosses over the freeway and ends at Baseline Drive. That intersection is more or less a half of a mile to the East of the aforesaid Sunland Springs Village perimeter wall. Accordingly, it is difficult to understand why the proposed extension of Meridian Road is located so close to the perimeter wall. Why should it not be located so that it may connect with the existing location of Meridian Road and continue on in a Southerly direction across Baseline, rather than directly adjacent to our house and that of many of our neighbors?

As a result of the proposed location, auto exhaust pollution and road traffic noise would be a matter of concern. In the proposal nothing is mentioned about a high wall that would deflect traffic noise away from all the existing houses. Further, the proposed location of Meridian Road directly adjacent to the perimeter wall, would most certainly result in lowering the market value of all the houses located to the West of such wall to our detriment. It would further diminish the peaceful and quiet enjoyment by the residents of their homes. As a matter of engineering concern the area in question is subject to fissures in the land. Surely the unstable nature of the land should cause consideration of moving the proposed Road farther to the East so as to avoid faulty engineering.

We object to the proposed location of Meridian Road. We respectfully request that you and your agency reconsider the proposal as herein suggested.

Respectfully;

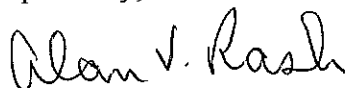

## Audra Koester Thomas

---

**From:** Lars Jacoby [Ljacob@azdot.gov]  
**Sent:** Tuesday, May 28, 2013 1:51 PM  
**To:** Audra Koester Thomas; Charla Glendening  
**Subject:** FW: Meridian Road Corridor Study-Response

**Follow Up Flag:** Follow up  
**Flag Status:** Flagged

FYI...

**Lars Jacoby**  
**Community Relations Project Manager**

1655 W. Jackson St.  
Mail Drop: 126F  
Phoenix, AZ 85007  
602.501.8493  
[azdot.gov](http://azdot.gov)



---

**From:** Marlys Enger [<mailto:facilitiesmanagement@live.com>]  
**Sent:** Tuesday, May 28, 2013 10:48 AM  
**To:** Lars Jacoby  
**Subject:** Meridian Road Corridor Study-Response

Dear Mr. Lars Jacoby:

Contact Information:

Name: Donald A. Marlys M. Enger

Address: 2259 So. Copperwood, Mesa, AZ 85209 (Sundland Springs Development)

Email address: [facilitiesmanagement@live.com](mailto:facilitiesmanagement@live.com)

Comments RE: Meridian Road Study:

We were unable to attend the presentation on May 16, 2013, however we have reviewed the printed materials regarding proposed recommendations for future improvements to Meridian Road.

**1. Setbacks:** The setback from the Farnsworth property line to the 'right of way' line indicate 13' for sidewalk & tree lane. The diagram does not indicate where the current waterway will be placed. This waterway contains water most of the winter months and provides drainage to the lots along the proposed roadway.

**We propose the Planner/Engineer retain the open waterway at the Maricopa/Pinal county line providing a greater "buffer" between the traffic lanes and the residential zoning with a minimum of 30' green/natural planted space** to buffer the highway activity to provide safety and security for the single family residential homes between Copperwood & Meridian Rd.

**2. Zoning/Use Permits:** The 2012 online Report indicates the "Zoned Use" contiguous with Meridian, between Baseline & Elliot Rd is planned as "multi-family residential".

**We recommend NO further "industrial zoning" permits be issued within the Meridian corridor for property contiguous with existing "residential use" zoning.**

**3. Speed Limit** - What is the proposed speed limit on this roadway between Elliot and Baseline Rd?

You may respond to our questions at 612-998-8470 or 952-835-0748 or [facilitiesmanagement@live.com](mailto:facilitiesmanagement@live.com)

---

Confidentiality and Nondisclosure Notice: This email transmission and any attachments are intended for use by the person(s)/entity(ies) named above and may contain confidential/privileged information. Any unauthorized use, disclosure or distribution is strictly prohibited. If you are not the intended recipient, please contact the sender by email, and delete or destroy all copies plus attachments.



# APPENDIX D

## SAMPLE MEMORANDUM OF UNDERSTANDING

**Baker**

**Michael Baker Jr., Inc.**  
*Phoenix, Arizona*

**MEMORANDUM OF UNDERSTANDING  
BETWEEN THE CITY OF APACHE JUNCTION, PINAL COUNTY, THE CITY OF MESA AND MARICOPA  
COUNTY FOR THE DEVELOPMENT OF THE MERIDIAN ROAD CORRIDOR FROM GERMANN ROAD TO  
MCDOWELL BOULEVARD**

**Project:**

The Meridian Road Corridor Study is an approximately thirteen (13) mile study between Germann Road and McDowell Boulevard. The purpose of the study is to develop a consensus driven vision for the Meridian Road Corridor, identify corridor deficiencies and requirements, and generate technically feasible alternatives designed to meet the established needs.

**Purpose:**

The purpose of this Memorandum of Understanding (MOU) is to establish design guidelines for Meridian Road from Germann Road to McDowell Boulevard and to outline the mutual understanding of Apache Junction, Pinal County, Mesa and Maricopa County regarding their respective roles in the planning, programming and project development of Meridian Road as defined in the corridor study completed by the Arizona Department of Transportation on behalf of Pinal County and Apache Junction in 2013.

**Background:**

The Arizona Department of Transportation (ADOT) kicked off the Meridian Road Corridor Study in 2012. As part of the completion of the study, the project partners agreed to develop Meridian Road with an arterial cross section with 60 feet to 150 feet of Right-of-Way depending on the location as depicted in Figure 1. The ultimate roadway configuration is depicted in Figure 2 and the preferred alignment is depicted in Figure 3. Cross sections of the agreed upon roadway are depicted in Figures 4 through 6.

**Project Guidelines:**

Road design and access guidelines for Meridian Road between Germann Road and McDowell Boulevard will follow the standards of the jurisdiction responsible for the operation and maintenance of the constructed improvements which remains to be negotiated among the partners. The design and guidelines should generally comply with the parameters in the Background section of this MOU.

**Responsibility of the Party Initiating the Development Action:**

1. Consult with and otherwise make available for review any master transportation plan, corridor study or any other planning study that impacts Meridian Road between Germann Road and McDowell Boulevard to all other parties to this MOU.
2. Consult with and otherwise make available for review any plans and specifications developed or submitted for Meridian Road to all other parties to this MOU.
3. Accept and consider in good faith, as appropriate, comments provided by other parties to this MOU.
4. Acknowledge ownership of or intent to acquire ownership of the road segment under development.
5. Provide ongoing operation and maintenance of the road segment under development.

**Responsibility of Others not Initiating the Development Action:**

1. Review any master transportation plan, corridor study or any other planning study that impacts Meridian Road between Germann Road and McDowell Boulevard in a timely fashion.
2. Review any plans and specifications developed or submitted for Meridian Road in a timely fashion.
3. Acknowledge and encourage ownership of or intent to acquire ownership by the Party initiating the development action and assist as appropriate or necessary.



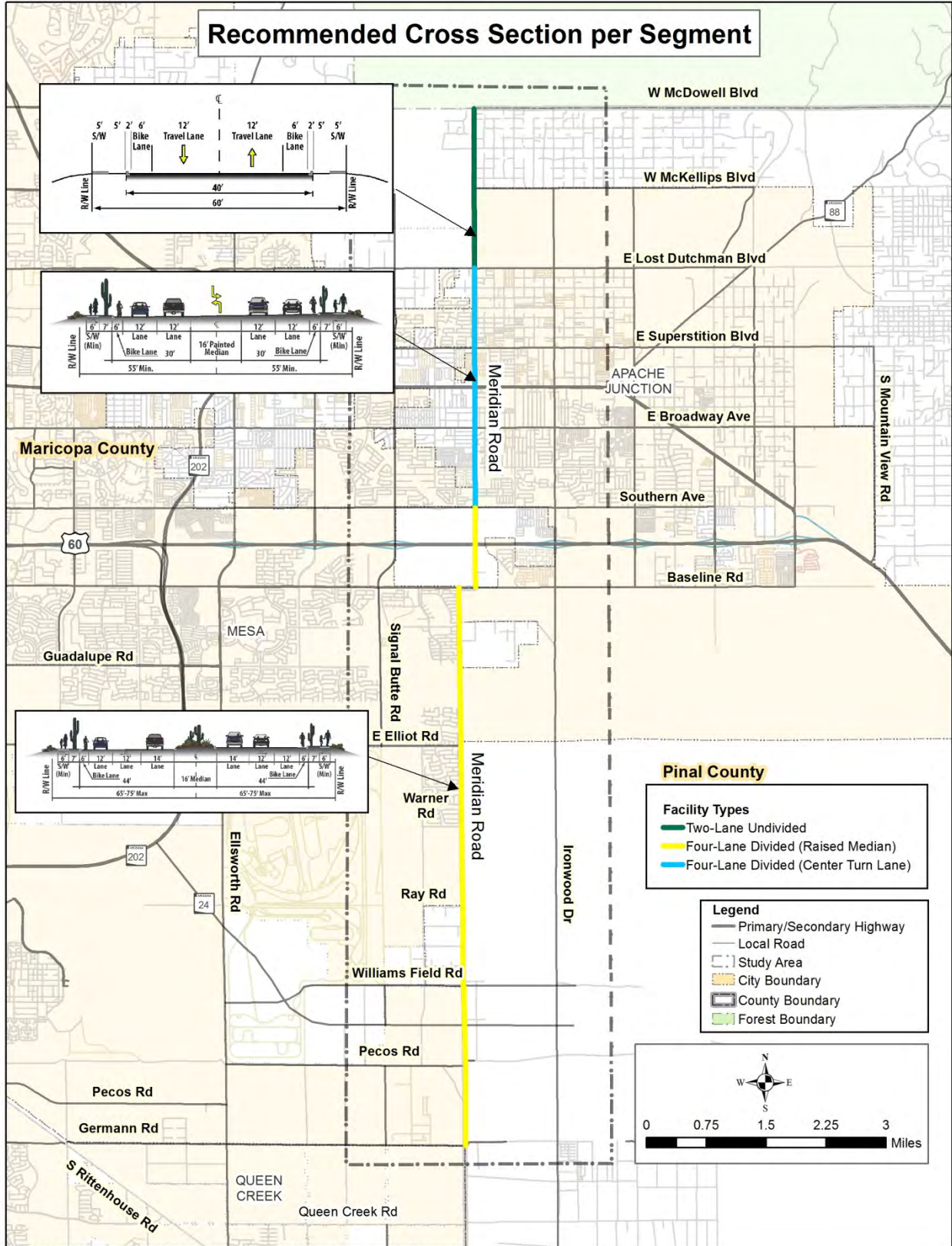

Figure 1: Recommended Cross Section per Meridian Road Segment



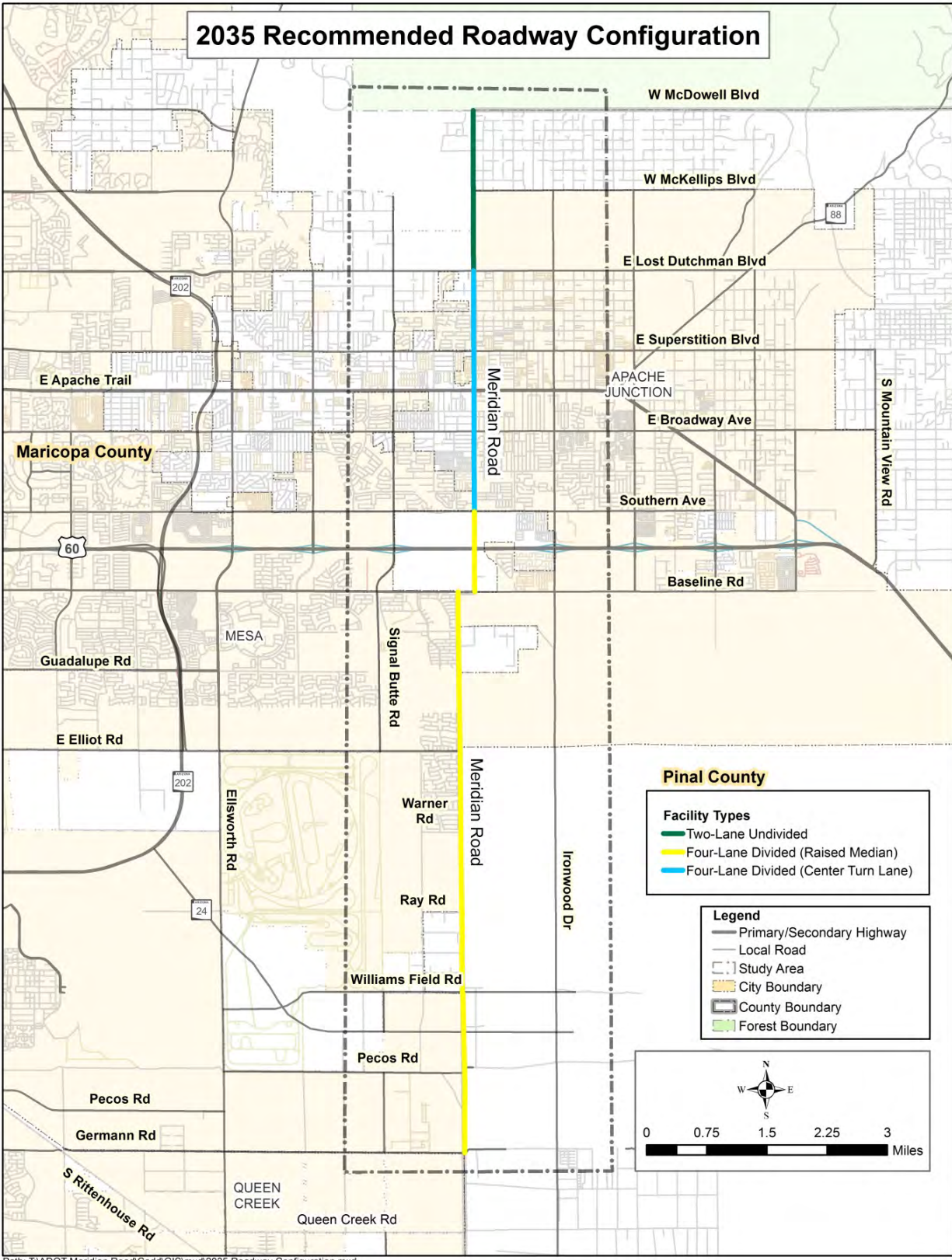
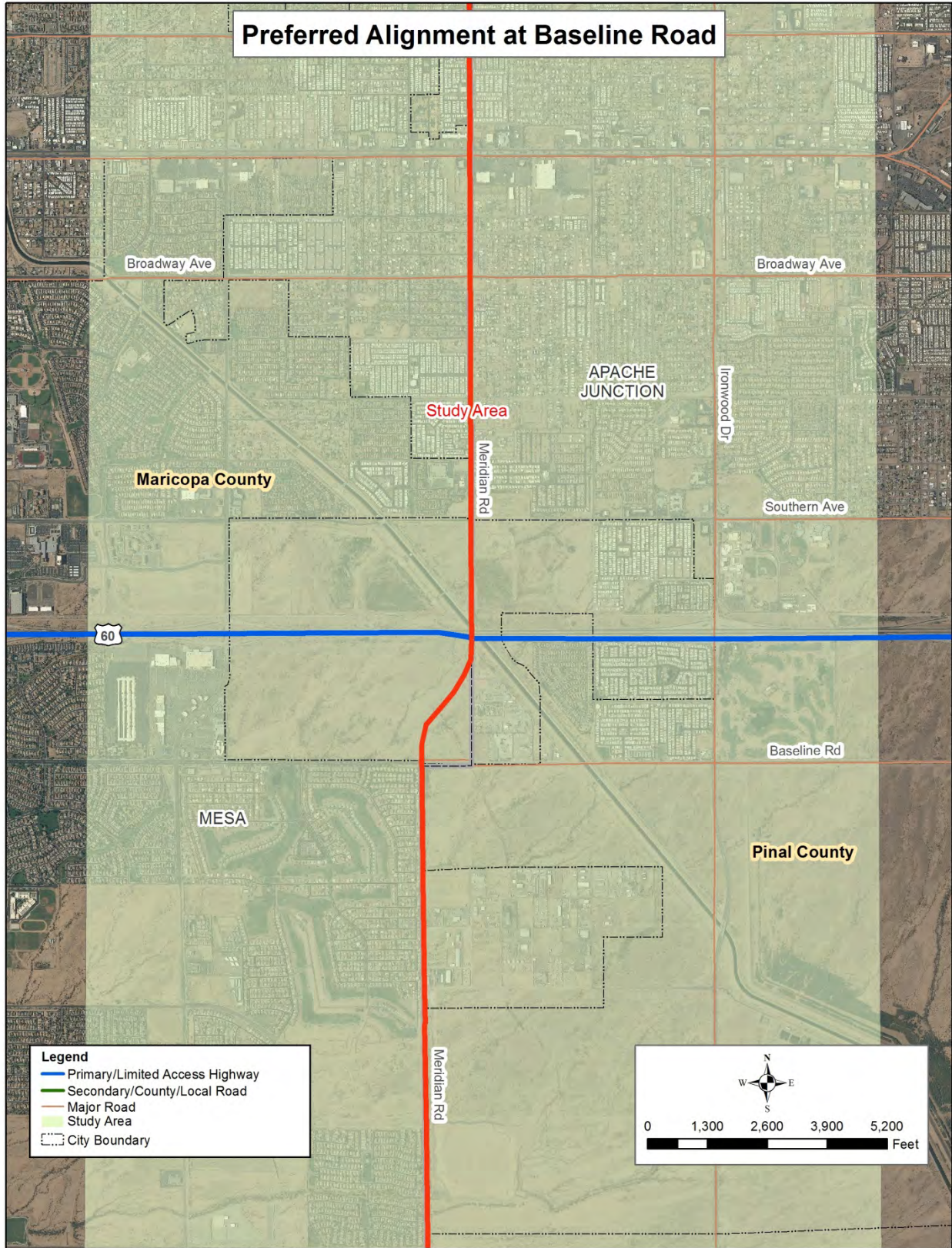

Figure 2: 2035 Recommended Roadway Configuration





**Figure 3: Meridian Road Preferred Alignment**



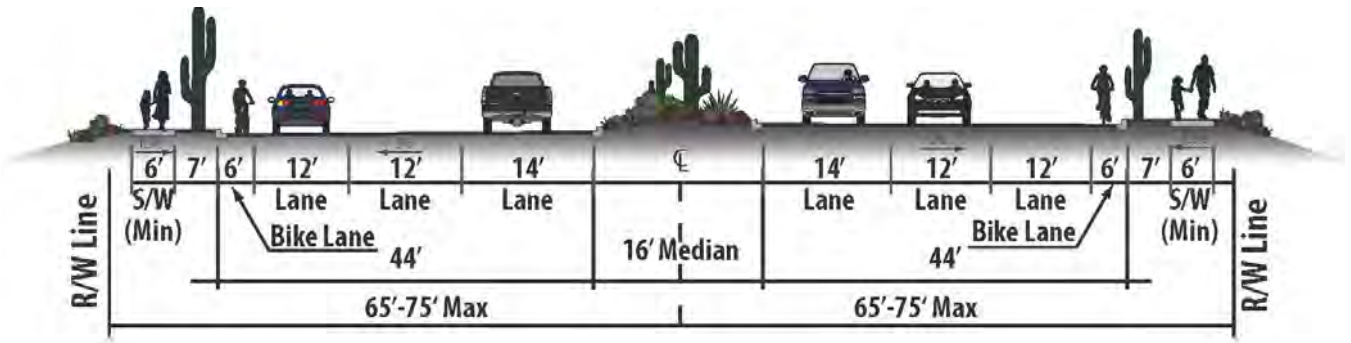

Figure 4: Ultimate Roadway Cross Section – Southern Avenue to Germann Road

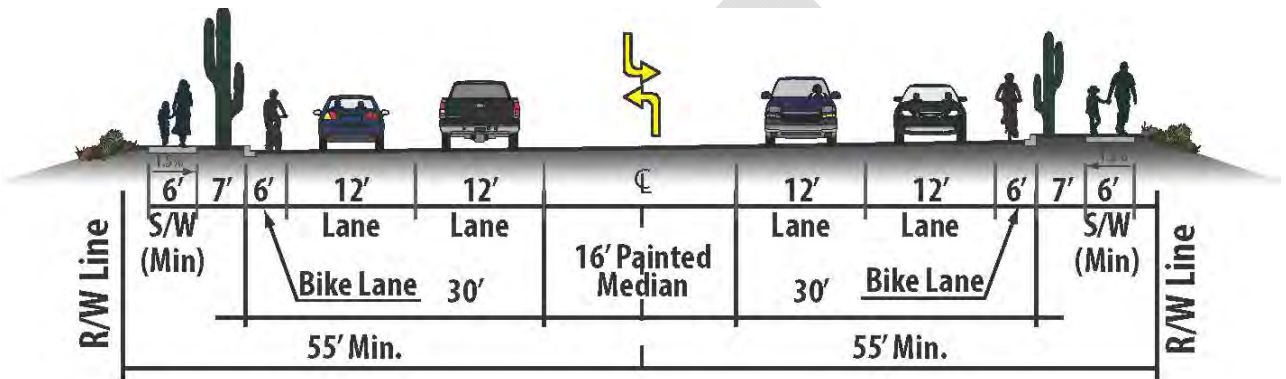

Figure 5: Ultimate Roadway Cross Section – Lost Dutchman Boulevard to Southern Avenue

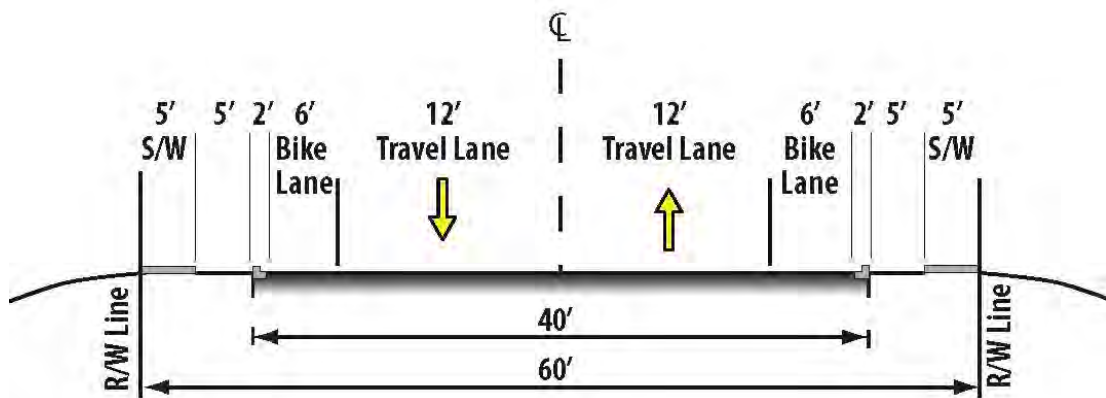

Figure 6: Ultimate Roadway Cross Section – Lost Dutchman Boulevard to McDowell Boulevard

# APPENDIX E

## MEETING NOTES

**Baker**

**Michael Baker Jr., Inc.**  
*Phoenix, Arizona*

# Meeting Report

<b>Subject/Purpose</b>	Meridian Road Corridor Study Project Kick-off Meeting Summary
<b>Attendees</b>	Doug Hansen, Pinal County Giao Pham, Apache Junction Charla Glendening, ADOT MPD Lynne Hilliard, Maricopa County DOT Simon Pratt, Baker Mike Sabatini, Baker
<b>Date/Time</b>	March 5, 2012

## General Notes

- The application was written by the Central Arizona Association of Governments (CAAG).
- Pinal County is the local sponsor and Apache Junction has a strong interest.
- The Apache Junction Comprehensive Transportation Plan is about to finish. The Plan assumes a build out population of 130,000. Jacobs travel demand modeling has been provided to CAAG.
- The study limits are Germann to McKellips.
- URS completed a design concept report for MCDOT between Empire and Southern.
- The Siphon Draw drainage basins and channel were recently completed.
- There is a half diamond interchange at 30% design phase for Meridian Rd at US 60 with an \$11.7 million budget for construction in FY 2013. It could be similar to the Sossaman TI.
- The intersection improvement/traffic signalization project at Southern/Meridian could go to construction in FY 2012. Giao has asked for 7-lane R.O.W. from the developer at the SE quad of the intersection. The development is a 55+ community similar to what exists at Ellsworth/Baseline.
- Mesa has road widening project in their CIP for Meridian near Elliot.
- Ironwood has 1-2 mile queues in the NB direction at Baseline in the a.m.
- Portales is a 7,700 acre master planned community on the east side of Meridian between Elliot and Baseline.
- The Pinal County North-South Freeway and SR 24 studies by ADOT will impact Meridian Road. There is a meeting at HDR about the NS study on March 6 to narrow 45 alternatives to 16. The SR 24 study is on hold and will proceed following the NS study.
- Apache Junction will look to others to fund road widening.
- RV resorts along Meridian in Apache Junction want improvements.
- ADOT can provide travel demand modeling.
- Need to be cognizant of floodplains and fissures.

- Study goals north of Baseline:
  - Prescreen drainage, R.O.W., etc. in preparation for future DCR
  - Conduct preliminary NEPA, develop a Purpose and Need statement
  - Follow the Planning and Environmental Linkages (PEL) process, ADOT has a checklist
- Study goals south of Baseline:
  - Determine timeframe of agencies' roadway development; Mesa timing of CIP project
  - Affirm facility type and cross section
  - Germann is an important E-W connector; Tom Condit is the Queen Creek contact; meet with Queen Creek before finalizing scope
  - SR 24 is an important E-W connector
  - Provide cost estimates through plan implementation
- Provide road inventory up to McDowell but Pinal County does not think it is necessary to plan
- Public outreach at least once and maybe twice. There was poor attendance at the first Apache Junction Comprehensive Transportation Study public meeting. Subsequent on-line outreach and survey monkey was more successful.
- The winter population doubles the summer population in Apache Junction.
- Anticipate 5 TAC meetings, 2 sets of public meetings, Working Papers 1 and 2, Final Draft and Final Reports with an Executive Summary, possible Pinal BOS and AJ Council presentations. Baker to provide all public meeting materials and CCP consultant will handle all arrangements and logistics. Charla will schedule TAC meetings and send invitations.
- The TAC will be:
 

<ul style="list-style-type: none"> <li>○ Pinal County, Doug Hansen, Andy Smith</li> <li>○ Apache Junction, Giao Pham</li> <li>○ Maricopa County DOT, Tim Oliver</li> <li>○ Mesa, Ken Hall</li> <li>○ Queen Creek, Tom Condit</li> </ul>	<ul style="list-style-type: none"> <li>○ FCDMC, Felicia Terry</li> <li>○ CAAG, Mark Griffin</li> <li>○ ASLD, Michelle Green</li> <li>○ MAG, Bob Hazlett</li> <li>○ FCDPC, Elise Moore</li> <li>○ ADOT CCP, Lars Jacoby</li> </ul>
---	---
- May meet as a group or separately with stakeholders:
  - Central Arizona Project
  - Phoenix-Mesa Gateway Airport, Walt Fix
  - Intercity Passenger Rail Study, Mike Kies
  - N-S Pinal Study/SR 24 Study, Javier Gurrola
- ADOT will establish a website for:
  - Meeting minutes
  - Working papers
  - Fold up executive summary
  - Other
- Baker to submit the scope and budget as separate documents in order to post the scope on the web and provide the schedule in PDF format. Send the draft scope to Giao and Doug for review.

- Meeting:** Meridian Road Corridor Technical Advisory Committee Meeting #1
- Location:** Queen Creek Library, Erma Bombeck Room  
21802 S Ellsworth Road, Queen Creek, Az 85242
- Date:** May 16, 2012
- Time:** 1:30 p.m.
- Attendance:** Mark Griffin, CAAG; Ken Hall, City of Mesa; Doug Hansen, Pinal County; Tim Oliver, MCDOT; Giao Pham, City of Apache Junction; Andy Smith, Pinal County; Charla Glendening, ADOT MPD; Cathy Regester, Flood Control District of Maricopa County; Jen Pokorski, Flood Control District of Maricopa County; Wayne Balmer, Town of Queen Creek; Ralph Ellis, ADOT Environmental Planning; Simon Pratt, Baker; Mike Sabatini, Baker; Audra Koester Thomas, PSA
- Handouts:** Agenda, Study Area Map, Work Plan, Public Involvement Plan Outline

Meeting began at 1:40 p.m.

### **1. Introductions**

Charla Glendening, ADOT Project Manager, introduced the project and Planning Assistance for Rural Areas (PARA) program to the Technical Advisory Committee (TAC). She introduced the “Planning and Environmental Linkages” (PEL) program, a precursor initiative to Design Concept Reports (DCRs), that would be included as part of this planning effort. Following review of the program, participants introduced themselves.

### **2. Project Overview/Work Plan**

Mike Sabatini, Baker Project Manager, noted the purpose of the project is to gain consensus on number of lanes, facility type and right of way for the Meridian corridor between McDowell and Germann roads, and to preserve the ability for future federal funding.

Mr. Sabatini reviewed a list of previous and current study efforts that would inform the Meridian Road Corridor project. Participants added the following additional studies: Mesa Transportation Plan (ongoing), Hydrology Study (2011), Power Road/Rittenhouse Flood Retarding Structure Study (ongoing), MAG RTP, and ADOT US 60/Meridian Road TI (ongoing).

Mr. Sabatini noted that while alternative alignments are not anticipated with the potential exception between Baseline and Southern, alternatives will likely focus on facility types, phasing options and implementation strategies.

Tim Oliver, MCDOT, noted that the challenges will be in the southern portion of the alignment, where fissures and miscellaneous development will impact alternatives. He also encouraged the team to reach consensus on the long-term ownership and maintenance of the facility, as well as the preferred cross section. Giao Pham, City of Apache Junction, noted that the Elliot Road Study might be a good model for determining facility type, and continued that phasing options should consider initial lanes, not just longitudinal development. Wayne Balmer, Town of Queen Creek, offered scalloped, interim phasing to address future development patterns along the corridor.

Ralph Ellis, ADOT Environmental Planning, reminded the group that if future federal funding was desired, multiple alternatives—including a no-build option—would need to be considered, as well as developing a strong purpose and need.

Because of the multiple jurisdictions along the corridor, Ms. Glendening inquired if a potential memorandum of understanding (MOU) regarding the facility type, right of way, phasing, etc. was a possible outcome of this effort, and after discussion, there seemed to be interest amongst the various jurisdictions to further investigating the creation of an MOU. Tim Oliver suggested looking at the MOU for Elliott Road between MCDOT and Mesa.

Mr. Sabatini noted that travel demand modeling for this project was unlikely, and instead, the team would utilize existing studies to estimate future level of service needs using syncro simulation. He noted that Nona Baheshone would be conducting the environmental review for the project.

### **3. Project Deliverables**

Mr. Sabatini noted the following schedule for deliverables:

- Technical Memorandum #1: May 2012
- Working Paper #1: September 2012
- PEL Questionnaire Part 1: September 2012
- Working Paper #2: November 2012
- Draft Final Report: November 2012
- Final Report: December 2012

### **4. Roadway Typical Sections**

Mr. Sabatini walked the TAC through the various road cross sections for Pinal County, Maricopa County, City of Apache Junction and City of Mesa, noting the similarities and differences of each. It was requested that access management guidelines be reviewed as part of the alternatives stage, perhaps using the 2006 study's policy language as guidance.



## **5. Public Involvement Plan**

Audra Koester Thomas, PSA, reviewed the public involvement plan outline and asked for feedback on what tactics should be utilized for outreach. After discussion, the use of a survey instrument in the beginning of the project was considered a viable alternative to a public meeting, where agencies could forward a project fact sheet with a link to the project website and survey to garner feedback. Agencies also recommended the study team attend other project meetings as a way to engage constituents, or meet with homeowners associations along the corridor.

## **6. Project Stakeholders**

Ms. Thomas reviewed the list of project stakeholders that the study team would interview to garner technical information to inform the project. TAC members offered the following additional stakeholders as potential interviewees: Arizona State Land Department, Corps of Engineers, Western Area Power Administration, SR 24 Project Manager, Area Drainage Master Plan areas, private water companies (Arizona Water, Apache Junction Water District), utility companies, homeowner associations, and Utery Mountain Park.

## **7. Elected Official Outreach**

Discussion ensued on whether agencies preferred having elected officials briefings, and agencies noted that at this time, forwarding the project fact sheet would be sufficient. Many noted that if an MOU is developed, study team briefings to elected officials might be beneficial at that time.

## **8. Planning and Environmental Linkages Program**

Mr. Sabatini reviewed the PEL program and how the initiative intends to weave together planning and the National Environmental Policy Act (NEPA), including a review of the various surveys that are part of the PEL process.

## **9. Open Discussion**

Mr. Oliver noted that it might be prudent to do intersection analysis at major/key intersections as part of the phasing discussion.

Mr. Balmer inquired as to how the project gets memorialized. Particular to the various jurisdictions involved, Mr. Balmer wondered if an MOU would convey consensus derived as part of the project.

## **10. Future Meetings**

Many TAC members noted that Wednesday afternoons were good meeting times.

Meeting adjourned at 3:35 p.m.

# Meeting Report

<b>Subject/ Purpose</b>	Meridian Road Corridor Study Meeting with Michelle Green, ASLD		
<b>Attendees</b>	Michelle Green, ASLD Charla Glendening, ADOT MPD Mike Sabatini, Baker	<b>Date/Time:</b>	June 4, 2012
<b>Follow Up Actions:</b>			
<b>Contacts Made</b>	Contact: Michelle Green Company: Arizona State Land Department Phone: 602-364-2502 Email: Mgreen@land.az.gov Comments: Real Estate Division, Planning and Engineering		

## General Notes

- Mike reviewed the PowerPoint presentation from May 16, 2012 TAC meeting.
- Michelle asked about Meridian Road section line transition at Baseline Road. Would it be better if it were south of Baseline instead of north as shown in the MCDOT report? Why not just extend the alignment due south from Baseline with no transition or transition at some point south of Baseline. Discussion follows about ensuring viable land uses in the transition zone or the use of the remnant strip if the alignment is offset east of the section line south of Baseline. Mike says the MCDOT alignment mimics transitions at other section line offsets at Crismon, Ellsworth, etc. and those have vibrant commercial uses in the transition zone.
- ASLD has not developed a detailed roadway network in Superstition Vistas which is the 275 square miles in Pinal County east of Meridian Rd and south of Baseline Rd.
- ASLD sold 1,000 acres of Superstition Vistas which has become the Portalis development with the stipulation that the developer deposit \$6,000,000 in an escrow account to fund master planning for Portalis and the full 275 sq. mi. of Superstition Vistas.
- Michelle will provide a PDF of the Superstition Vistas planning document. There is no similar document for Portalis.
- Michelle advises to correct the Summary of Existing Studies slide to show that the Superstition Vistas document is a Conceptual Land Use Plan.
- ASLD does not have an advisory committee. There might be a benefit to brief the State Land Commissioner as the plan formalizes and if the partners develop an MOU.



## MEETING SUMMARY



**Project:** East Mesa ADMP Update  
**Job No.:** FCD 2011C017  
**Subject:** ASLD Coordination Meeting

**Date:** August 16, 2012  
**Time:** 10:00 a.m.  
**Place:** ASLD

<u>Attendee</u>	<u>Affiliation</u>	<u>E-mail</u>
Jen Pokorski	FCDMC	jpm@mail.maricopa.gov
Lillian Moodey	ASLD	Lmoodey@azland.gov
Manny Patel	ASLD	Mpatel@azland.gov
Adam Sharp	ASLD	Asharp@azland.gov
Ruben Ojeda	ASLD	Rojeda@azland.gov
Simon Pratt	Baker	Spratt@mbakercorp.com
Mike Sabatini	Baker	Michael.Sabatini@mbakercorp.com
Hernan Aristizabal	Entellus	ahernan@entellus.com
Laurie Miller	LTM Engineering	miller@LTMengineering.com

The following is a summary of a meeting with the Arizona State Land Department (ASLD) to discuss future drainage and transportation corridors and partnering opportunities within the East Mesa Area Drainage Master Plan (ADMP) Update study area. The agenda, attendance sheet, and handouts are attached.

### **Project Background**

Jen Pokorski, project manager for the Flood Control District of Maricopa County (District), noted that Entellus was retained to update the East Mesa ADMP, originally developed in 1998. The update was initiated due to significant changes in the watershed and ongoing flooding concerns within the study area. Additionally, rainfall data has recently been updated and new mapping is available.

Significant flooding in Maricopa County has occurred in the Mountain Road area and along Pecos and Germann Roads at the Meridian Road alignment. The runoff originates in Pinal County and crosses into Maricopa County at Meridian Road. The need for constructing drainage infrastructure is immediate due to active flooding; however, actual implementation will be contingent on funding partnerships.

Concurrently, the Arizona Department of Transportation (ADOT) has retained Michael Baker Corporation to perform a transportation study along Meridian Road between McDowell and Germann Roads. The corridor study is funded through ADOT's Planning Assistance for Rural Areas (PARA), with Pinal County and the City of Apache Junction as participating jurisdictions. Mike Sabatini is Baker's project manager for the Meridian Road Corridor Study.

### **Preliminary ADMP Alternatives**

Hernan Aristizabal, project manager for Entellus, presented preliminary alternatives under consideration. Three alternatives have been developed for each of three geographical areas:

**SR 24 System:** areas north of the future SR24 alignment (runoff to be captured by the future SR 24 interceptor channel)

**Ellsworth System:** area between the future SR24 alignment and Germann Road (drains to the Ellsworth Channel)

**Rittenhouse System:** southern portion of the study area (drains to the Rittenhouse Channel)

All three systems impact state trust lands along Meridian Road alignment. The majority of adjacent land on the east side within the study area is held in trust. On the west side, the adjacent land is privately owned and is substantially more developed. It was noted that 70 feet of street right-of-way has been secured along portions of the Maricopa County side, though not along the entire length of the corridor. These existing right-of-way segments would be used for the future road, but additional land will be required for roadway right-of-way and drainage easement. Mike Sabatini noted that securing right-of-way for the entire length of the corridor will be a study recommendation.

Segments of the Meridian Road drainage improvements under consideration include routing the channel alignment eastward around existing private development in Pinal County near Williams Field Road. Development has occurred on both sides of the Meridian Road alignment; although the roadway could be constructed between the developments, there is not enough available width to accommodate an adjacent open channel. Alternatively, a straight alignment could be maintained along the section lines and the channel could include a buried box or pipe section in the vicinity of Williams Field Road. ASLD expressed a preference for the underground segment. It was noted that, in addition to being less efficient hydraulically, the offset channel segment would result in a significant increase in land acquisition since the District would be required to purchase any parcels that would be segmented by a shifted channel.

Additionally, the Ellsworth System alternatives include a drainageway along Pecos Road. A parcel of state trust land along the south side of Pecos Road would be impacted by two of the proposed alternatives. ASLD would not support Alternative 3 because it divides this parcel and negatively impacts its viability for future development.

### **Future Development & Infrastructure Plans along Meridian Road**

Mike Sabatini reported that a prior roadway study of Meridian Road by the Maricopa County Department of Transportation (MCDOT) had recommended a six-lane arterial roadway with 130 feet of right-of-way, which includes an on-pavement bike lane and an adjacent sidewalk. The concept design also included a raised median and a 10-year channel to convey road drainage. The MCDOT study acknowledged the improvements recommended in the 1998 East Mesa ADMP, but did not include them as part of the roadway recommendations. The report recommended a series of cross road culverts with 50-year or 100-year designs, depending on the drainage identified.

The current Baker study is based on the same footprint and is centered on the section lines, except in the vicinity of Baseline Road where the section lines are offset. An interchange is planned for access to US 60 from Meridian Road, but implementation of the remainder of the corridor study is indefinite.

ASLD requested additional information on the ADOT Meridian Road Corridor Study. Mike Sabatini will make it available on an ftp site.

ASLD noted the following:

- ASLD has detailed GIS coverage available of lands held in trust. Jen Pokorski will coordinate obtaining the files.
- Based on typical roadway and channel cross sections for Meridian Road provided by Entellus, the overall channel widths along Meridian Road are relatively high due to the inclusion of landscaping and other aesthetic treatments. It was clarified that a moveable bed, i.e., earthen bottom, channel was assumed. ASLD seeks to achieve a balance between aesthetic enhancements with associated greater land requirements and straight, narrower channels with minimal aesthetics.
- The current policy when right-of-way is required along state trust land is to share the burden equally with the adjacent landowner(s). Extenuating circumstances, e.g., the desire to avoid condemnation proceedings against existing development, may warrant a deviation from this policy. However, any such deviation would first require careful study.
- ASLD's preference is to locate a drainage channel adjacent to the roadway rather than shift the channel upstream "behind" future development:
  - Actual development patterns cannot be predicted; therefore, construction of a channel upstream of assumed development could reduce rather than enhance property values when the land is later offered for purchase.
  - Future development adjacent to Meridian Road would still need an outfall for onsite runoff. A channel on the upstream side of the roadway would provide an outfall; a channel located farther upstream would not.
- Manny Patel noted that ASLD would be interested in future development being allowed to drain directly to a channel along Meridian Road with waived retention requirements. Since the area in question is within Pinal County, it would also need to allow such a waiver. Additionally, downstream facilities may need to be upsized to accept the runoff directly.
- The current study offers a benefit to ASLD because it eliminates the 1998 recommendation to construct detention basins on state trust land in the vicinity of Pecos Road.
- ASLD would be willing to consider allowing extension of the existing 70-foot Meridian Road right-of-way eastward to accommodate the wider road/channel corridor. However, ASLD would not contribute construction funds.
- The study results should recommend forming a Memorandum of Understanding or Inter-Governmental Agreement between ASLD and the District if partnering opportunities are proposed.

### Potential Future Partnering Opportunities

The East Mesa ADMP Update project will select a preliminary recommended alternative in September or October 2012 and will present it to stakeholders, including ASLD, and the public at that time. The project will be complete in February 2013.

The Meridian Road Corridor Study will be completed by December 2012 and will include a public meeting at that time.

Jen Pokorski will contact Michelle Green, ASLD's planner for east Mesa, to discuss future plans for the region.

### Summary

ASLD noted the following:

1. A narrower channel cross section is preferred in order to reduce the amount of land required.
2. In developed areas, it is acceptable to analyze extending the existing 70-foot right-of-way along Meridian Road eastward, recognizing that the overall roadway/channel width will exceed 140 feet. In undeveloped areas, the right-of-way would be split evenly between adjacent state trust lands and private owners.
3. Future development on state trust land adjacent to channels along Meridian Road should be allowed to discharge directly in lieu of retaining the 100-year, 2-hour storm.
4. Where possible, proposed channels should not be shifted onto state trust lands.

### Action Items

The following action items were assigned:

Action Items	Responsible Party
Obtain GIS shapefiles of state trust lands	Jen Pokorski
Contact Michelle Green for ASLD planning information in east Mesa	Jen Pokorski
Provide information via ftp on the ADOT Meridian Road Corridor Study	Mike Sabatini
Include Ruben Ojeda on future ADMP stakeholder notifications	Laurie Miller

The preceding summary was prepared by Laurie Miller.

c: Attendees





**MEETING AGENDA  
East Mesa ADMP Update  
Coordination with Arizona State Land Department  
August 16, 2012**

---

**1. Introductions & Project Background**

- Project Summary
- Project Goals
- Purpose of Meeting
  - Coordinate future drainage and roadway corridors in East Mesa

**2. Presentation of Preliminary Drainage Plan Alternatives**

- SR 24 System
- Ellsworth System
- Rittenhouse System

**3. Discussion of Future ASLC and MCDOT Plans along Meridian Road**

- Future Development Plans
- Meridian Road Corridor Study
- Drainage Constraints along Meridian Road
  - Roadway width requirements
  - Drainage conveyance requirements
  - Future accommodations for commercial development

**4. Potential Future Partnering Opportunities**

- Project Timeframes
- Funding Partnerships
- Regulatory Constraints

**5. Other**

# Meeting Attendance Sign-In Sheet

PLEASE PRINT INFORMATION

Date: Aug. 16, 2012

Project / Application No.: Meridian Rd. / East Mesa ADMP

Name	Company/Agency	Phone No.	Email address
1 Lillian Moody	ASLD	602-542-2443	lmoodey@azland.gov
2 Murray Pestel	ASLD	602-364-1596	mpestel@azland.gov
3 Jen Pokocski	FCD	526-4695	jnp@mail.maricopa.gov
4 Dory Williams	FCD	506-8743	DAW@Mail.Maricopa.Gov
5 Simon PRATT	BAKER	602-819-6586	spratt@mbakercorp.com
6 Mike Sabatini	Baker	602-798-7571	michael.sabatini@mbakercorp.com
7 Laurie Miller	LTM Engineering	602-485-5880	lmiller@LTMengineering.com
8 Herman Aristizabal	Entellus, Inc.	602 244 2566	AHernan@Entellus.com
9 Adam W. Sharp	ASLD	602-542-1725	asharp@azland.gov
10 RUBEN OLIVERA	ASLD/PCW	602-542-2648	ROLIVERA@AZLAND.GOV
11			
12			
13			
14			
15			
16			

1	2	3	4
9	8	7	6
5			

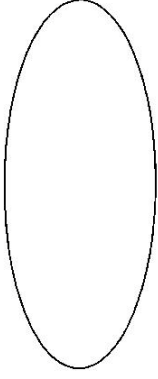
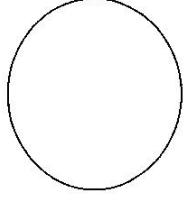
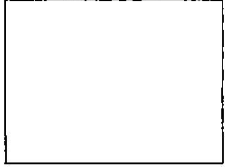



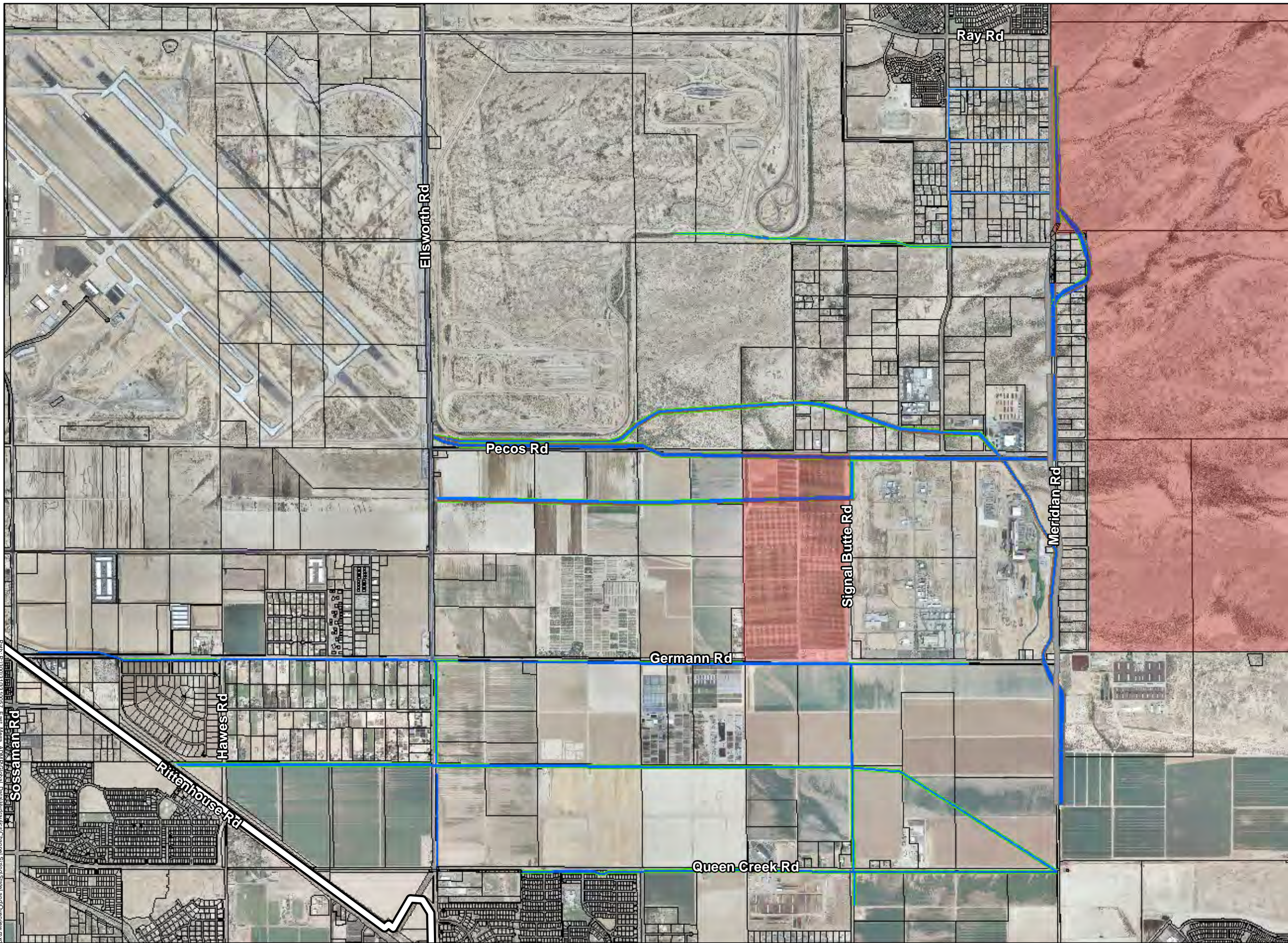









EAST MESA  
AREA DRAINAGE  
MASTER PLAN UPDATE  
FCD 2011C017

LEGEND

-  East Mesa ADMPU
-  State Trust Land
-  Parcels
-  Underground
-  Landscaping
-  Future Roadway
-  Channel
-  O&M

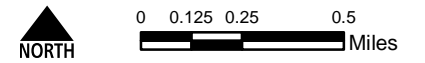

2255 N. 44th Street Suite 125  
Phoenix, Arizona 85008.3299  
Tel. 602.244.2566  
Fax. 602.244.8947  
Web. www.entellus.com



Alternatives Overview Map



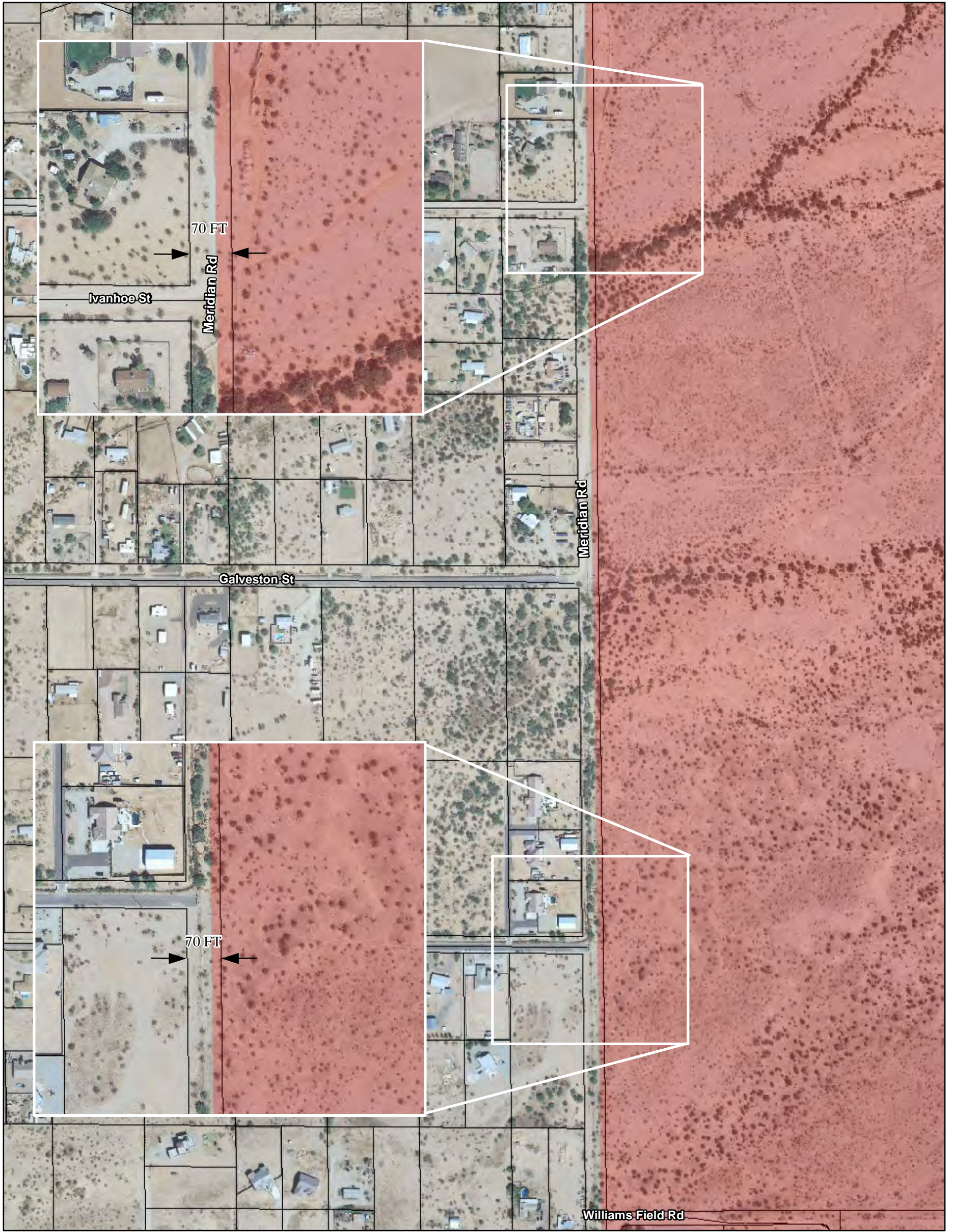



Path: P:\300\310\310057\_East\_Mesa\_ADM\Global\_Data\Hydraulics\Channel\_Sizing\StateLand\SR-24\_North.mxd



**EAST MESA  
AREA DRAINAGE  
MASTER PLAN UPDATE  
FCD 2011C017**

**LEGEND**

-  Parcels
-  State Trust Land

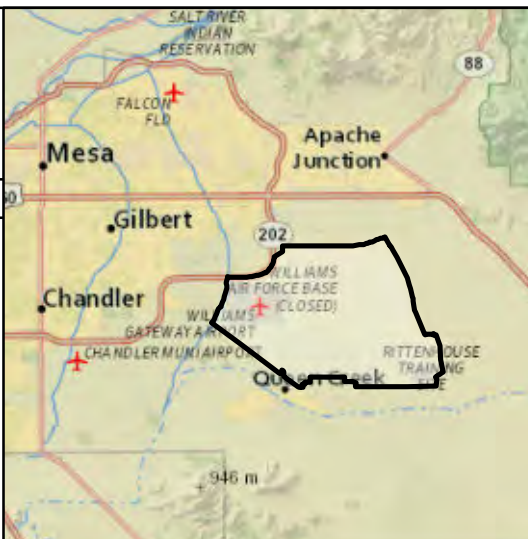

0 125 250 500 Feet



2255 N. 44th Street Suite 125  
Phoenix, Arizona 85008.3299  
Tel. 602.244.2566  
Fax. 602.244.8947  
Web. www.entellus.com



**SR-24 Movable Bed Channel**



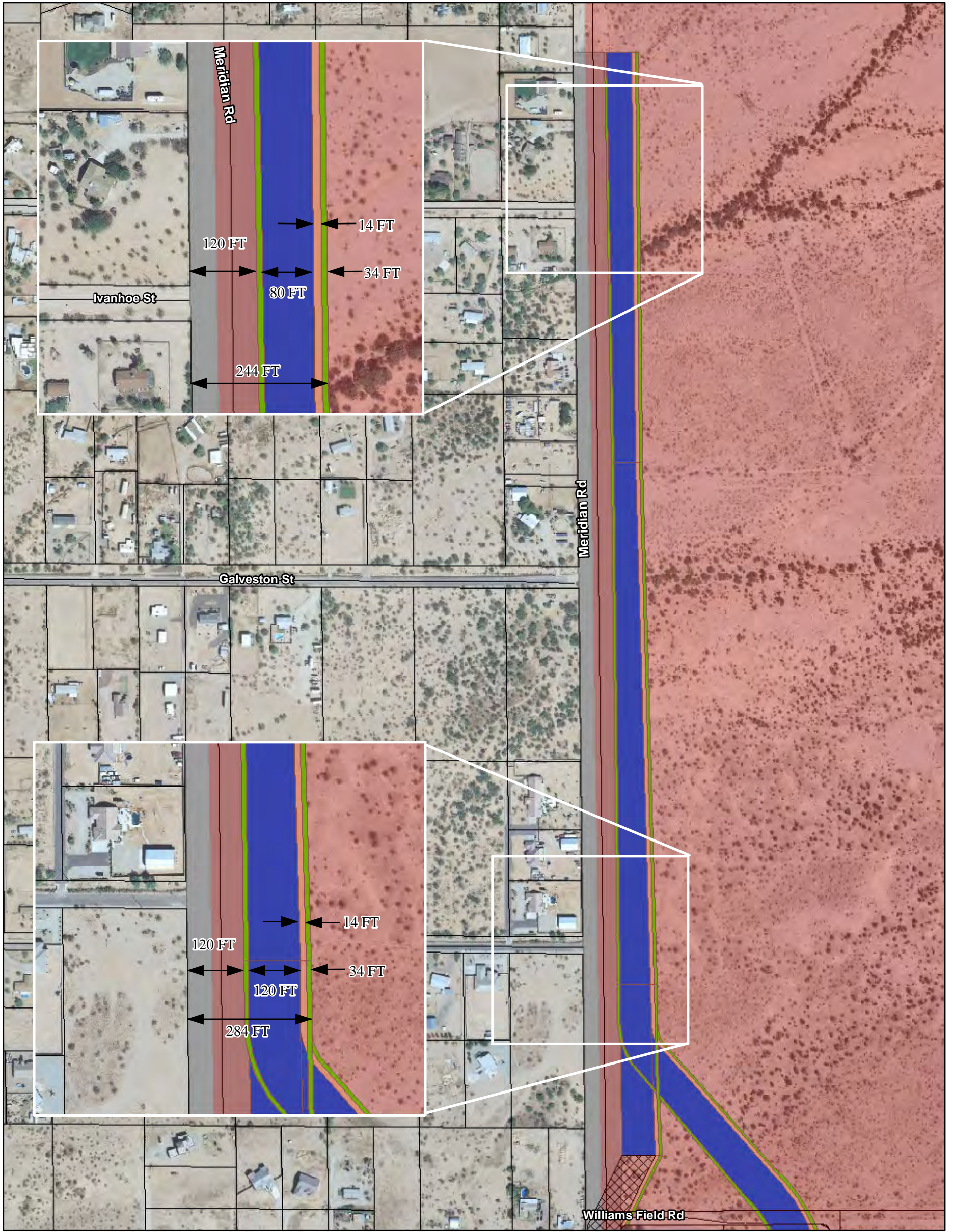

Path: P:\30013\10310057\_East\_Mesa\_ADM\PI\Global\_Data\Hydraulics\Channel\_Sizing\StateLand\SR-24\_NorthChannels.mxd



**EAST MESA  
AREA DRAINAGE  
MASTER PLAN UPDATE  
FCD 2011C017**

**LEGEND**

- Parcels
- State Trust Land
- Landscape
- Future Roadway
- Channel
- O&M
- Underground

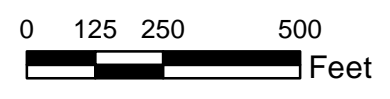

2255 N. 44th Street Suite 125  
Phoenix, Arizona 85008.3299  
Tel. 602.244.2566  
Fax. 602.244.8947  
Web. www.entellus.com



**SR-24 Movable Bed Channel**



Path: P:\3001310\310057\_East\_Mesa\_ADM\Global\_Data\Hydraulics\Channel\_Sizing\StateLand\SR-24\_North\_TypSection\_Alternative.mxd

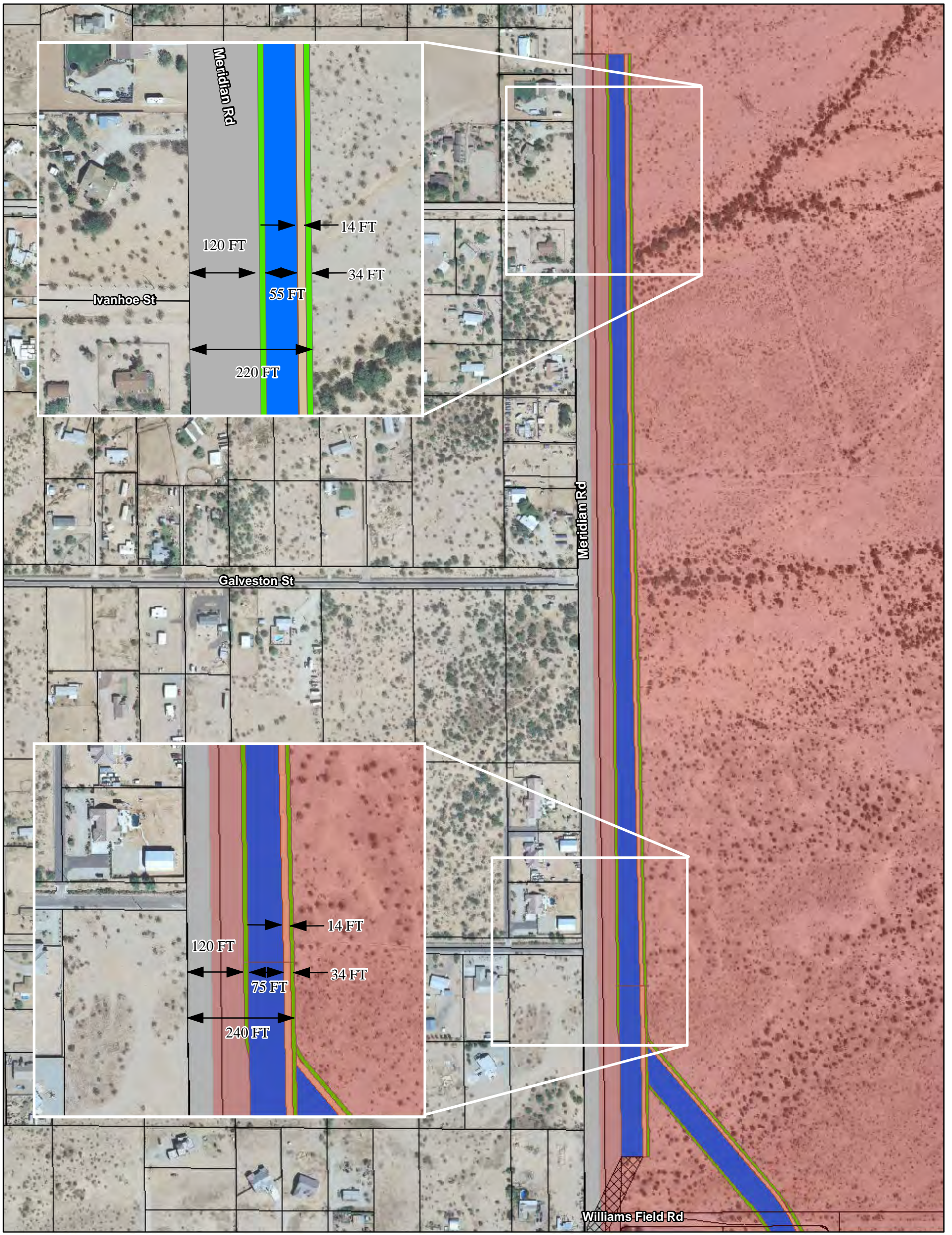

**EAST MESA  
AREA DRAINAGE  
MASTER PLAN UPDATE  
FCD 2011C017**

**LEGEND**

- Parcels
- State Trust Land
- Landscape
- Future Roadway
- Channel
- O&M
- Underground

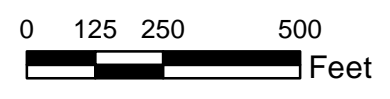

2255 N. 44th Street Suite 125  
Phoenix, Arizona 85008.3299  
Tel. 602.244.2566  
Fax. 602.244.8947  
Web. www.entellus.com



**SR-24 Typical Cross Section Channel**



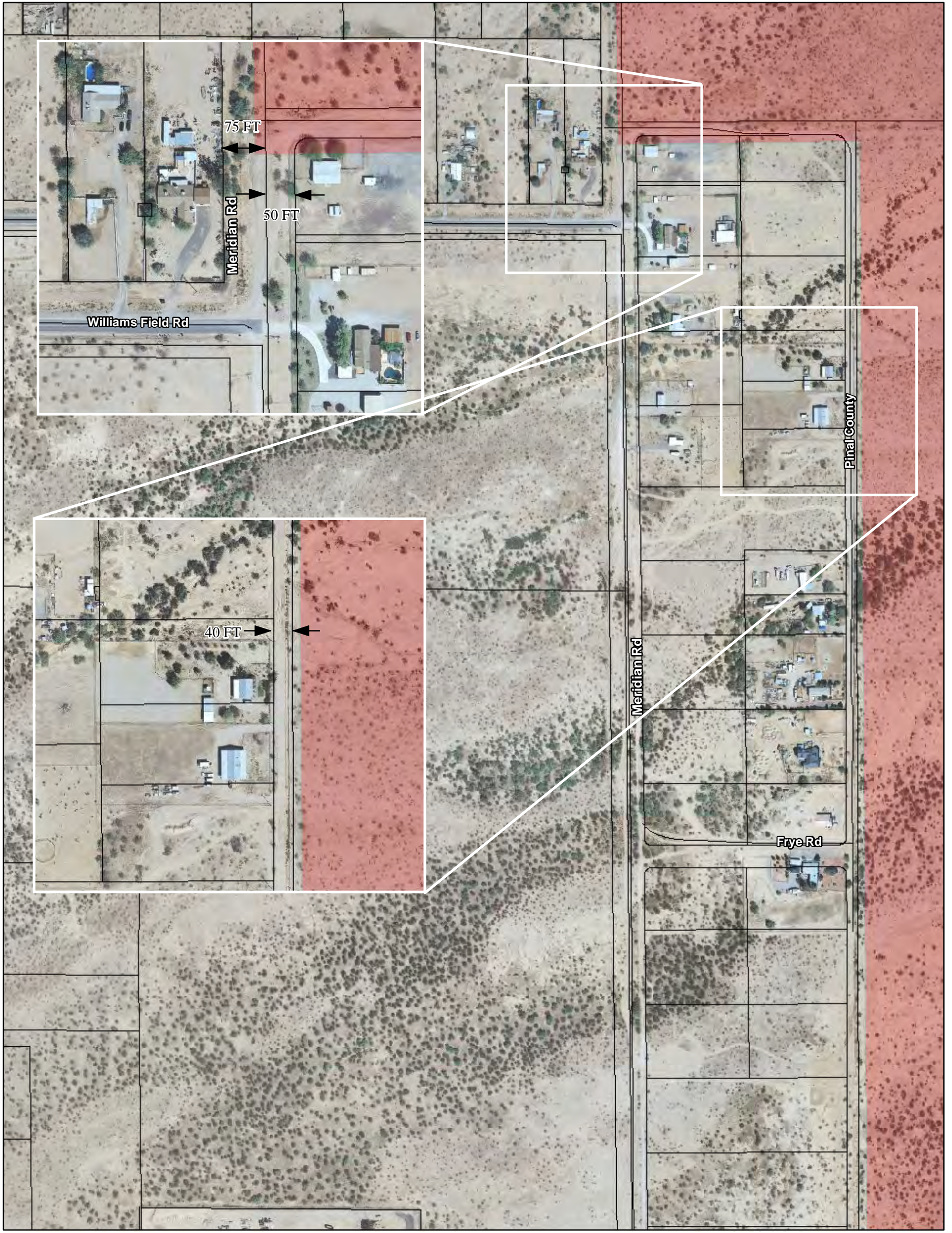



Path: P:\30013\10310057\_East\_Mesa\_ADM\Global\_Data\Hydraulics\Channel\_Sizing\StateLand\SR-24\_South.mxd



**EAST MESA  
AREA DRAINAGE  
MASTER PLAN UPDATE  
FCD 2011C017**

**LEGEND**

-  Parcels
-  State Trust Land

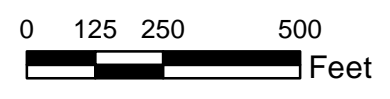

2255 N. 44th Street Suite 125  
Phoenix, Arizona 85008.3299  
Tel. 602.244.2566  
Fax. 602.244.8947  
Web. www.entellus.com



**SR-24 Movable Bed Channel**



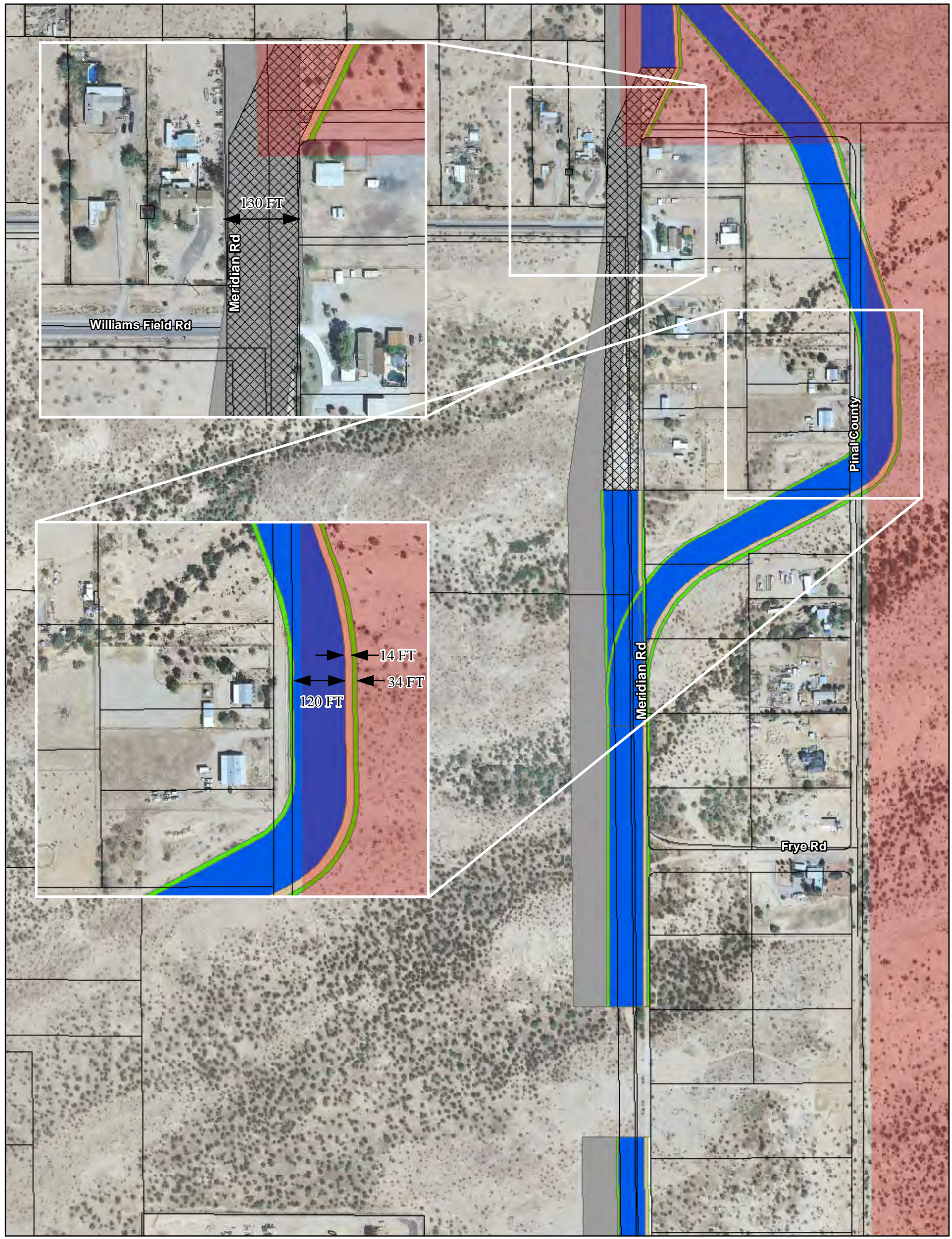







Path: P:\30013\10310057\_East\_Mesa\_ADM\GIS\Global\_Data\Hydraulics\Channel\_Sizing\StateLand\SR-24\_SouthChannel.mxd



**EAST MESA  
AREA DRAINAGE  
MASTER PLAN UPDATE  
FCD 2011C017**

**LEGEND**

-  Parcels
-  State Trust Land
-  Underground
-  Landscape
-  Future Roadway
-  Channel
-  O&M

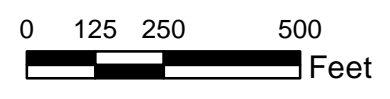

2255 N. 44th Street Suite 125  
Phoenix, Arizona 85008.3299  
Tel. 602.244.2566  
Fax. 602.244.8947  
Web. www.entellus.com



**SR-24 Movable Bed Channel**



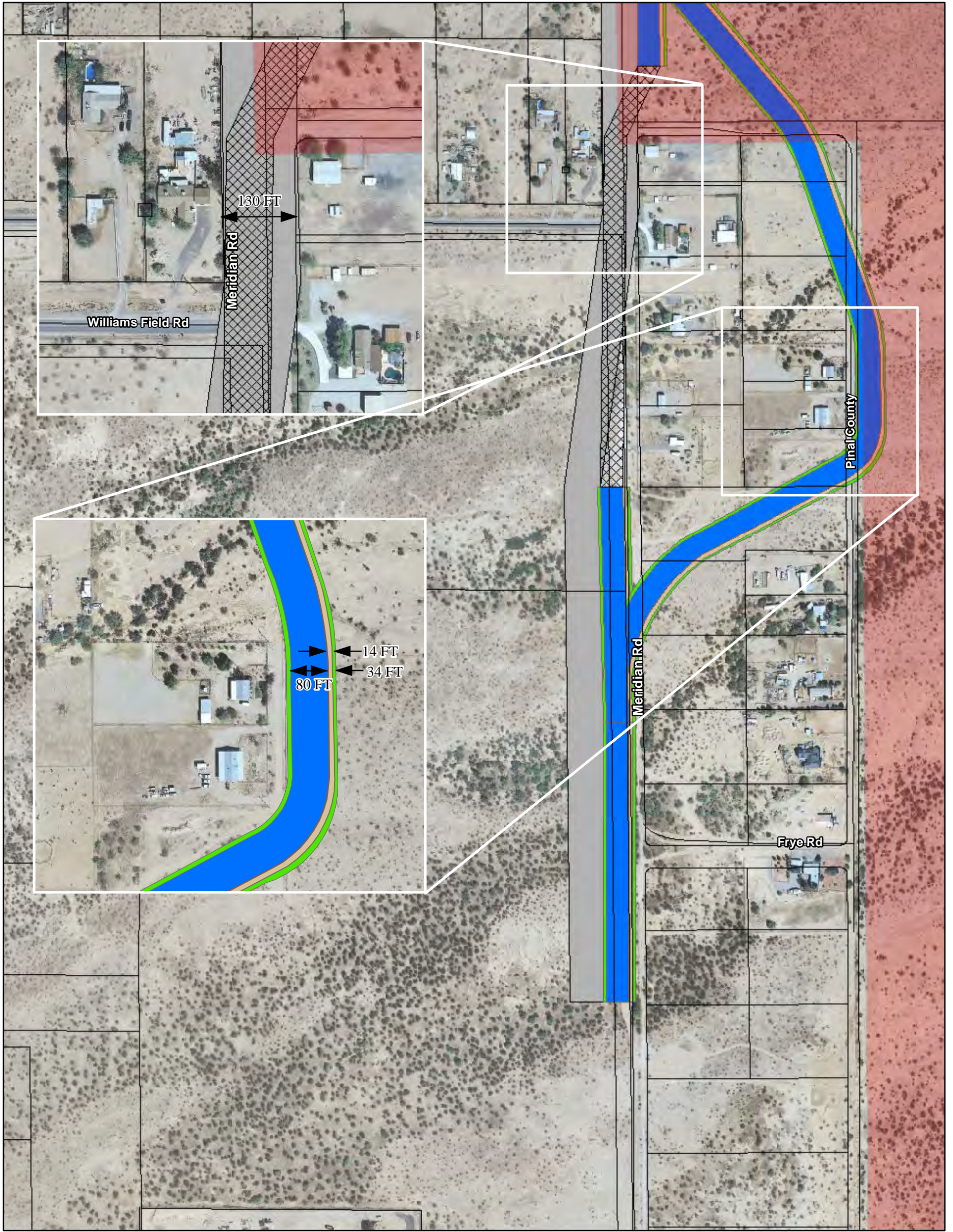

**EAST MESA  
AREA DRAINAGE  
MASTER PLAN UPDATE  
FCD 2011C017**

**LEGEND**

- |  |                  |  |                |
|--|------------------|--|----------------|
|  | Parcels          |  | Underground    |
|  | State Trust Land |  | Landscape      |
|  |                  |  | Future Roadway |
|  |                  |  | Channel        |
|  |                  |  | O&M            |

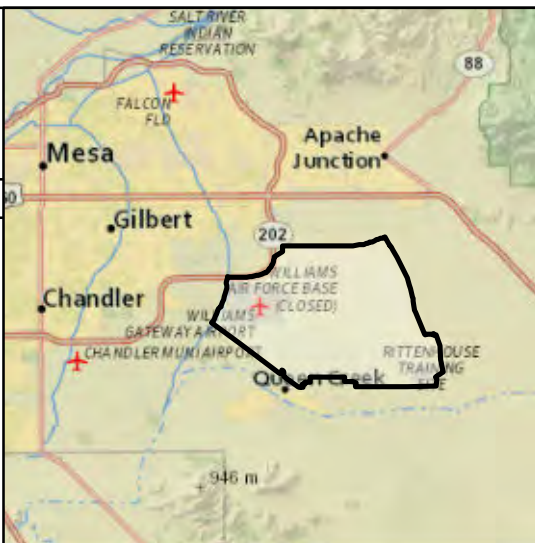

0 125 250 500  
Feet



2255 N. 44th Street Suite 125  
Phoenix, Arizona 85008.3299  
Tel. 602.244.2566  
Fax. 602.244.8947  
Web. www.entellus.com



**SR-24 Typical Cross Section Channel**



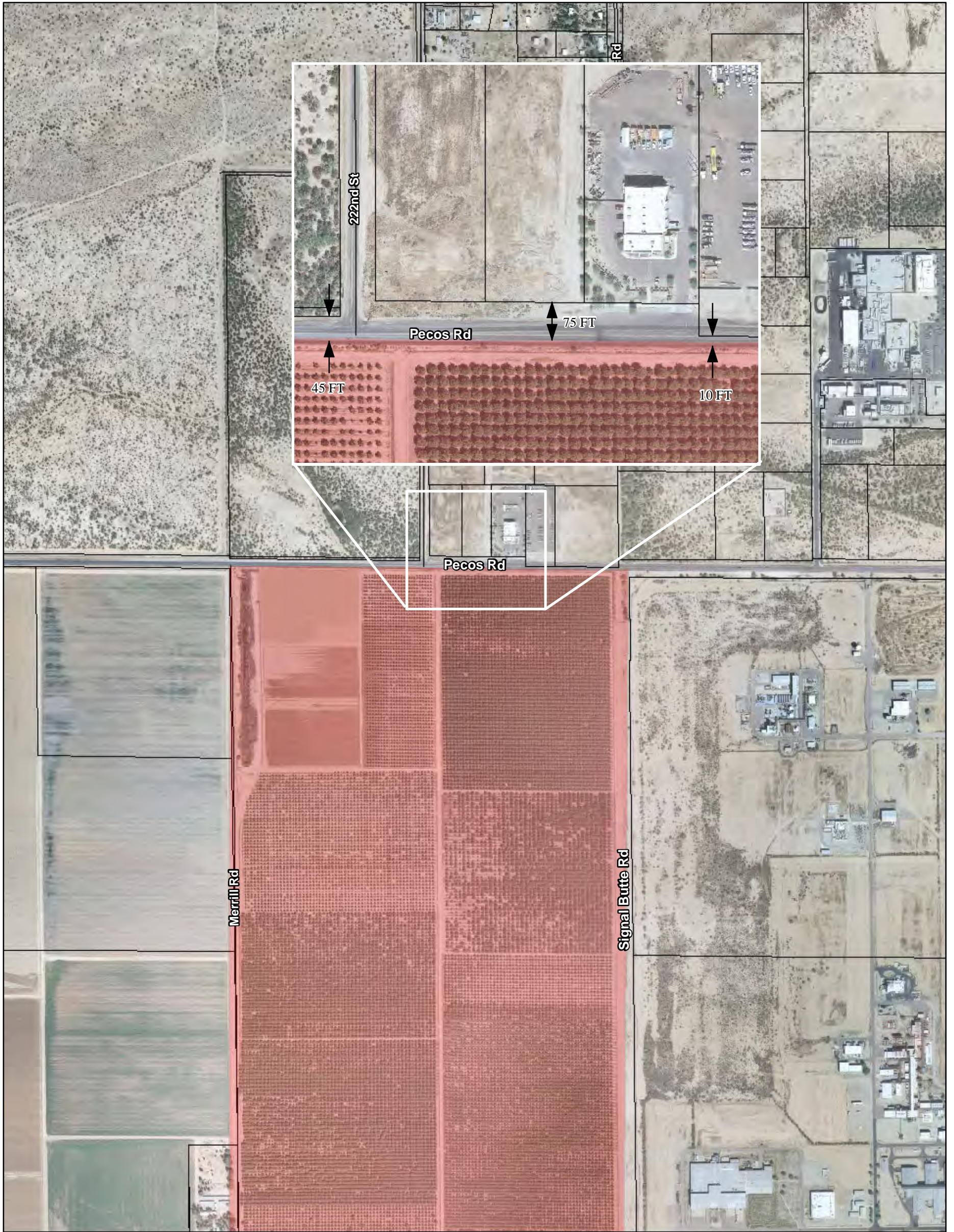

Path: P:\300\310\310057\_East\_Mesa\_ADM\Map\Global\_Data\Hydraulics\Channel\_Sizing\StateLand\Pecos\_ROW.mxd



**EAST MESA  
AREA DRAINAGE  
MASTER PLAN UPDATE  
FCD 2011C017**

**LEGEND**

- State Trust Land
- Parcels

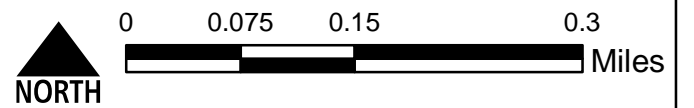
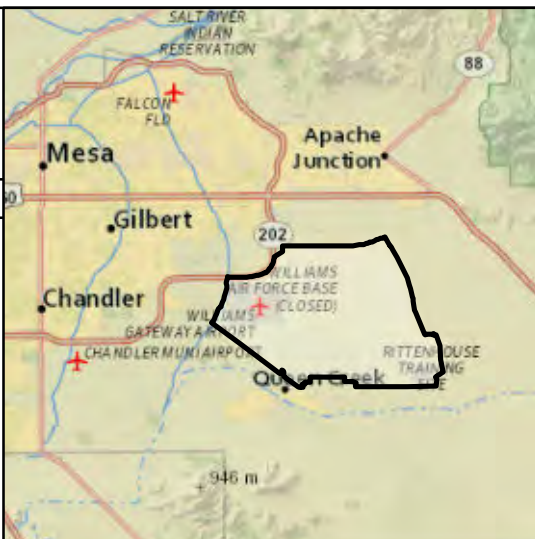

2255 N. 44th Street Suite 125  
Phoenix, Arizona 85008.3299  
Tel. 602.244.2566  
Fax. 602.244.8947  
Web. www.entellus.com



**Pecos Channel**



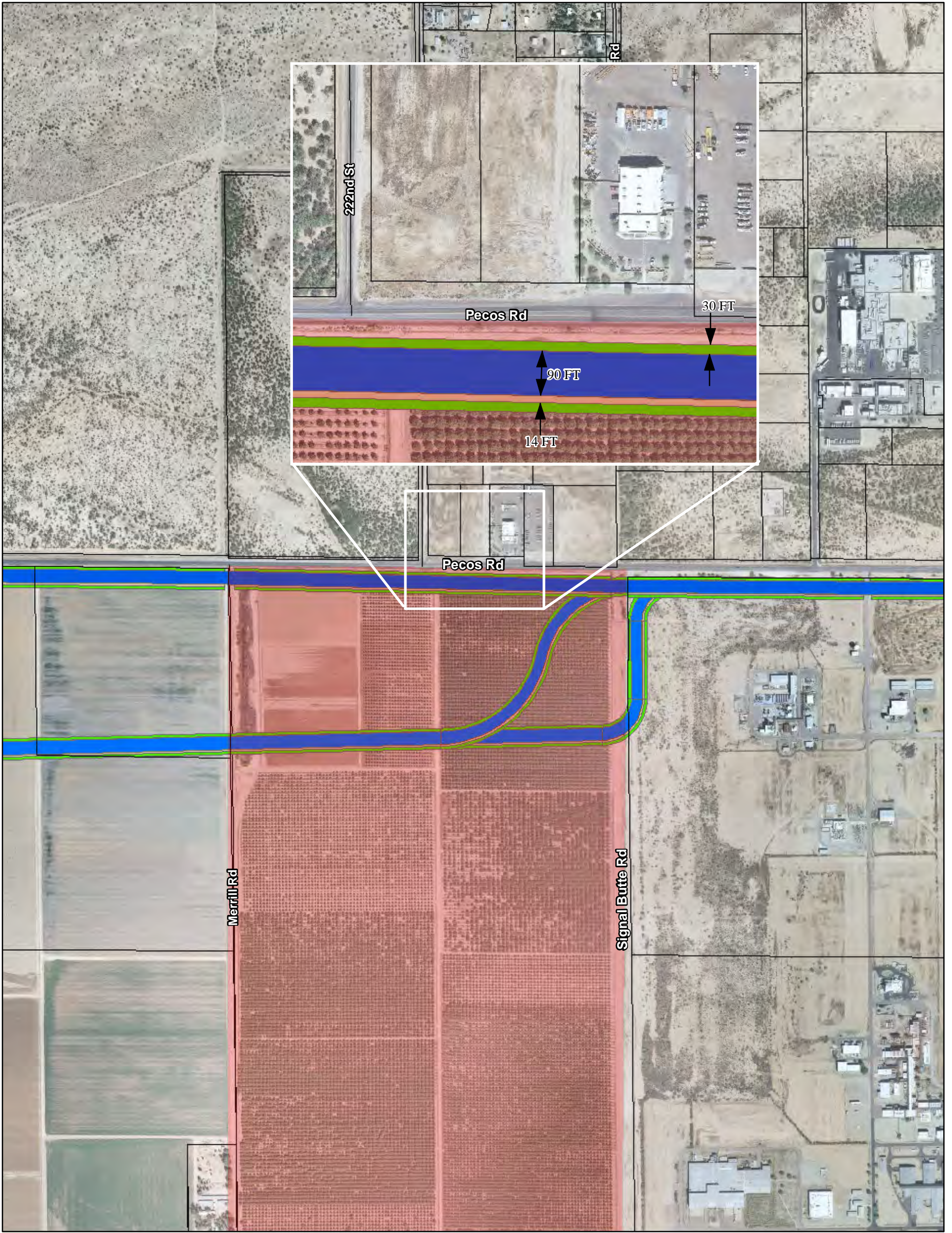

Path: P:\300\310\310057\_East\_Mesa\_ADM\Globe\Drawings\Hydraulics\Channel\_Sizing\StateLand\Pecos\_Channels.mxd



**EAST MESA  
AREA DRAINAGE  
MASTER PLAN UPDATE  
FCD 2011C017**

**LEGEND**

- State Trust Land
- Parcels
- Landscaping
- Channel
- O&M



**Entellus**  
2255 N. 44th Street Suite 125  
Phoenix, Arizona 85008.3299  
Tel. 602.244.2566  
Fax. 602.244.8947  
Web. www.entellus.com

**epg** **KTM** **JE FULLER**  
Engineering, Inc.

**Ningo & Moore**

**Pecos Channel**



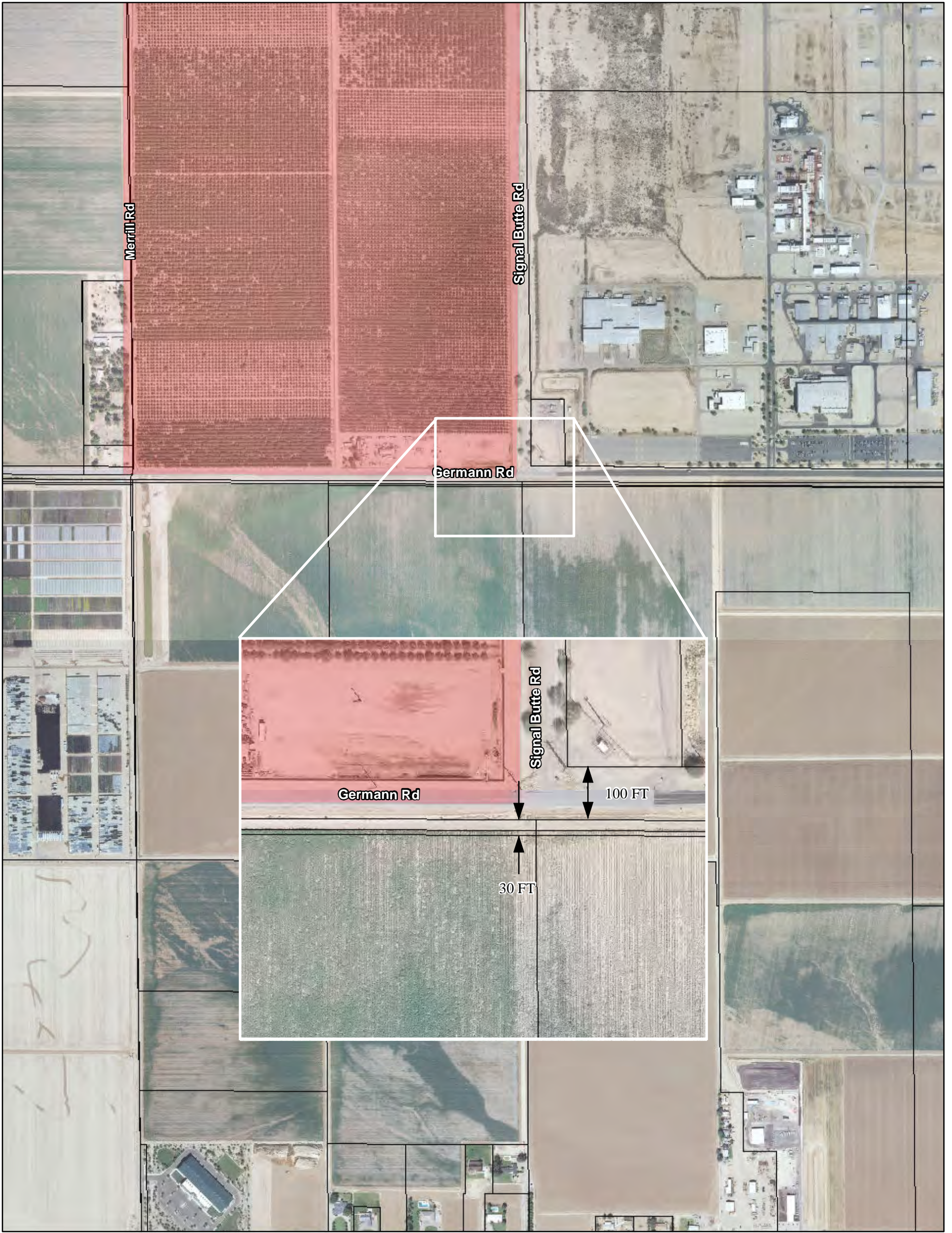

Path: P:\300\310\310057\_East\_Mesa\_ADM\Global\_Data\Hydraulics\Channel\_Sizing\StateLand\Germann.mxd



**EAST MESA  
AREA DRAINAGE  
MASTER PLAN UPDATE  
FCD 2011C017**

**LEGEND**

- State Trust Land
- Parcels

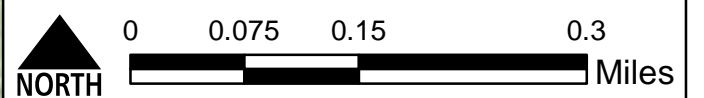
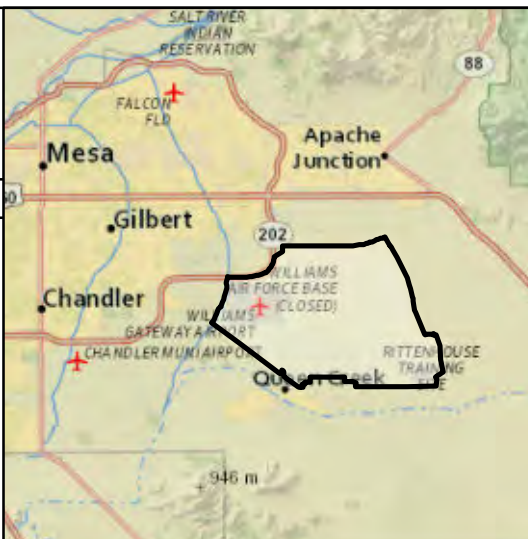

**Entellus**  
2255 N. 44th Street Suite 125  
Phoenix, Arizona 85008.3299  
Tel. 602.244.2566  
Fax. 602.244.8947  
Web. www.entellus.com



**Ningo & Moore**

**Germann Channel**



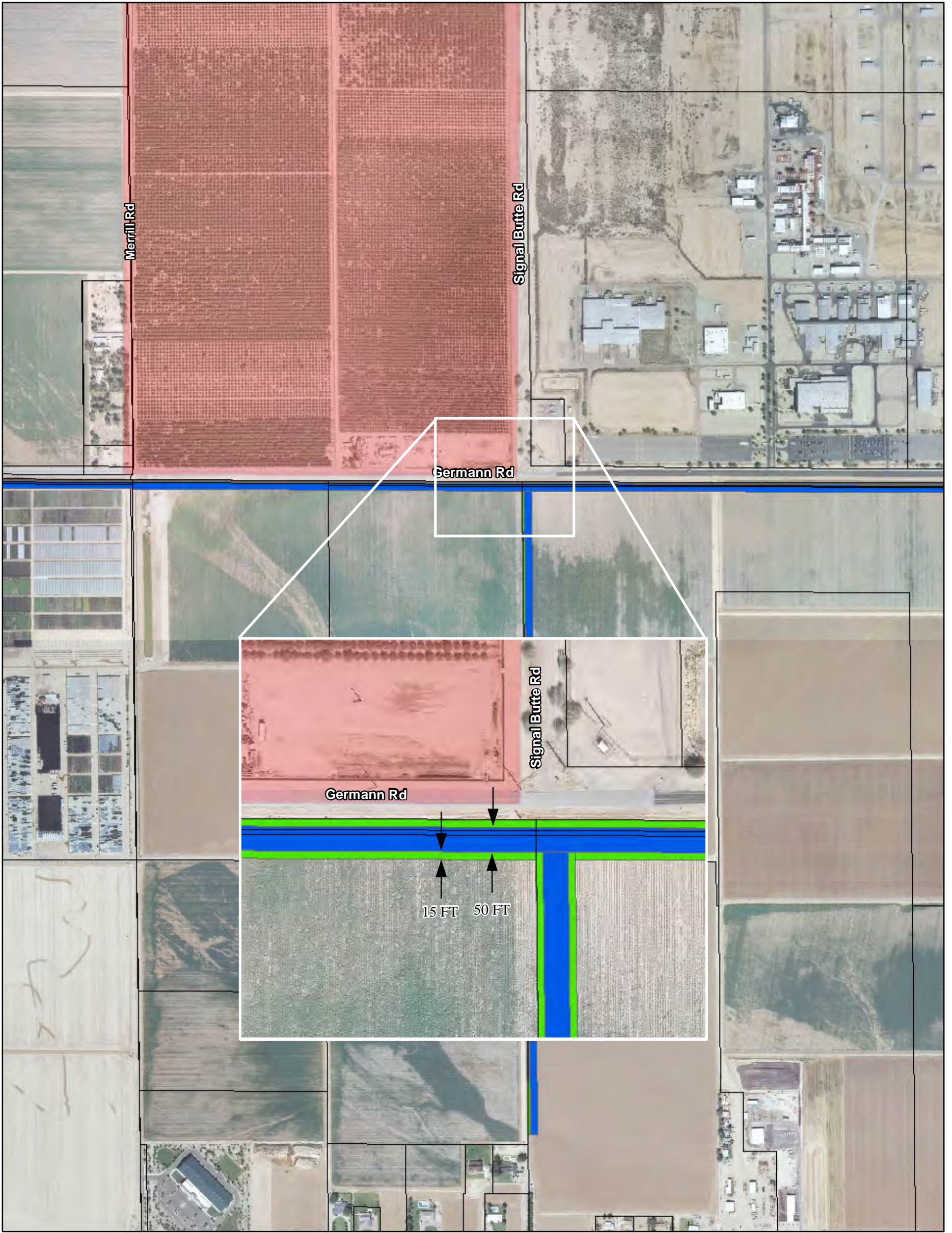





Path: P:\300\310\310057\_East\_Mesa\_ADM\Globe\Drawings\Hydraulics\Channel\_Sizing\StateLand\Germann\_Channel.mxd



**EAST MESA  
AREA DRAINAGE  
MASTER PLAN UPDATE  
FCD 2011C017**

**LEGEND**

-  State Trust Land
-  Parcels
-  Landscaping
-  Channel
-  O&M

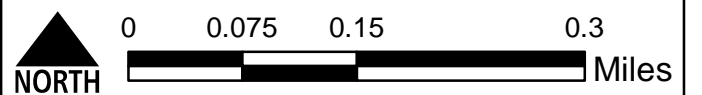
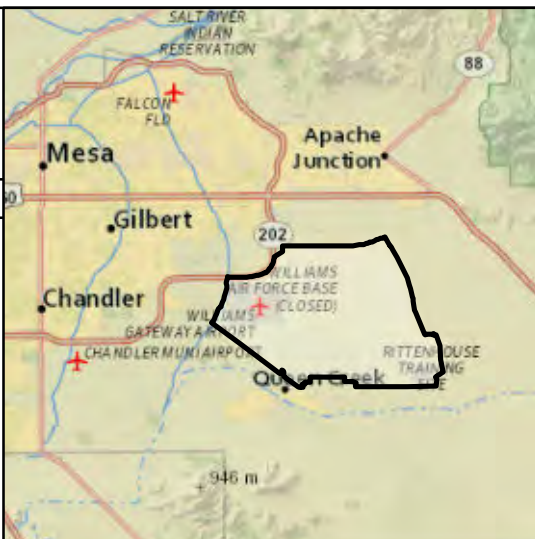

2255 N. 44th Street Suite 125  
Phoenix, Arizona 85008.3299  
Tel. 602.244.2566  
Fax. 602.244.8947  
Web. www.entellus.com



**Germann Channel**



- Meeting:** Meridian Road Corridor Technical Advisory Committee Meeting #2
- Location:** Queen Creek Library, Edward Abby Room  
21802 S Ellsworth Road, Queen Creek, Az 85242
- Date:** November 14, 2012
- Time:** 1:30 p.m.
- Attendance:** Michelle Green, Arizona State Land Department; Mark Griffin, CAAG; Ken Hall, City of Mesa; Doug Hansen, Pinal County; Micah Henry, MAG; Denise Lacey, MCDOT; Giao Pham, City of Apache Junction; Jen Pokorski, Flood Control District of Maricopa County; Charla Glendening, ADOT MPD; Simon Pratt, Michael Baker Corporation; Mike Sabatini, Michael Baker Corporation; Audra Koester Thomas, PSA
- Handouts:** Agenda, Elliot Road Maintenance MOU

Meeting began at 1:40 p.m.

### 1. Introductions

Charla Glendening, ADOT Project Manager, provided a welcome and asked participants to introduce themselves.

### 2. Working Paper #1

Mike Sabatini, Michael Baker Corporation (Baker) Project Manager, reviewed that the purpose of the meeting is to present Working Paper #1, Existing & Future Condition Inventory, and to review and address comments to finalize the report.

Simon Pratt, Baker Transportation Engineer, walked participants through the content of Working Paper #1. The following comments were provided:

- VII. Environmental Summary: Need to add information regarding the presence of fissures [Flood Control District of Maricopa County (FCDMC) can provide fissure data]
- VIII. Future Conditions: Considerable discussion ensued regarding the FCDMC plans for a future channel proximate to the corridor. Both FCDMC and ADOT are coordinating efforts, and as part of this study, it is desired that the channel recommendation be included as part of the roadway alignment and design for Meridian Road. As such, it was determined that a special meeting be held in December, prior to planned outreach by FCDMC in January 2013, to further discuss and define a recommended channel approach.
- X. Future Traffic Volumes: Need to show future planned roadways, such as SR 24, to help demonstrate future needs and levels of service.

In addition to the comments relative to Working Paper #1, it was recommended that the team acquires the updated North-South Corridor Study and reflect the latest alternatives within the study.

### **3. Development of Alternatives**

Mr. Pratt highlighted the various roadway classifications, cross section details and configurations each jurisdiction defines for the Meridian Road corridor. Discussion ensued regarding an approach to defining the desired, future roadway classification, cross section and configuration for the Meridian Road corridor. It was determined that Ms. Glendening would work with Baker to determine how to meet or work with each jurisdiction in order for the consulting team to prepare an initial recommendation for discussion and review. The TAC agreed that a memorandum of understanding (MOU) to memorialize the corridor's future functional classification, cross section and configuration would be a desired outcome of this study effort. Mr. Sabatini handed out the Elliot Road MOU for reference.

### **4. Public Outreach**

Audra Koester Thomas, PSA, noted that she'd been working with Jen Pokorski, FCDMC, regarding the potential for the study team to attend a future public meeting regarding the East Mesa ADMP project. Ms. Pokorski anticipated the public meeting to occur in January, whereby the Meridian Road study team could host a table regarding the project. In advance of that effort, the TAC confirmed that launching a survey instrument to obtain feedback on the following corridor topics would be desired:

- Opportunities, constraints and observations?
- Experience any problems?
- Agree/disagree: 6-lane divided arterial south of US 60 (Superstition Freeway)?
- Agree/disagree: 6-lane divided arterial between US 60 (Superstition Freeway) and Superstition Boulevard; 2-lane roadway north?
- Opportunities for non-motorized improvements? and/or How would you utilize non-motorized improvements?
- Ideas for long-range plans?
- How often do you travel the corridor?
- Do you live/work/own property along the corridor?

A mailer would be developed and sent to property owners adjacent to the corridor and agency partners could forward or otherwise distribute the flier to their constituents to garner feedback.

Meeting adjourned at 3:10 p.m.

**Meeting:** East Mesa ADMP Update and Meridian Road Corridor Study Coordination

**Location:** Queen Creek Library, Edward Abby Room  
21802 S Ellsworth Road, Queen Creek, Az 85242

**Date:** December 12, 2012

**Time:** 1:30 p.m.

**Attendance:** Afshin Ahouraiyan, Flood Control District of Maricopa County; Hernan Aristizabal, Entellus; Wayne Balmer, Town of Queen Creek; Michelle Green, Arizona State Land Department; Ken Hall, City of Mesa; Doug Hansen, Pinal County; Denise Lacey, MCDOT; Laurie Miller, LTM Engineering; Elise Moore, Pinal County; Tom Narva, TOQC; Ruben Ojeda, Arizona State Land Department; Tim Oliver, MCDOT; Manny Patel, Arizona State Land Department; Giao Pham, City of Apache Junction; Jen Pokorski, Flood Control District of Maricopa County; Charla Glendening, ADOT MPD; Simon Pratt, Michael Baker Corporation; Mike Sabatini, Michael Baker Corporation; Audra Koester Thomas, PSA

**Handouts:** Agenda, ADMP System Alternatives, Meridian Corridor Alignment map, Meridian Corridor Existing Land Use map, Meridian Corridor Land Ownership map, Baseline Alternative Alignment map, ADMP channel data and sample cross sections

Meeting began at 1:35 p.m.

### **1. Introductions**

Mike Sabatini, Michael Baker Corporation (Baker) Project Manager, provided a welcome and asked participants to introduce themselves.

### **2. East Mesa ADMP**

Jen Pokorski, Flood Control District of Maricopa County, provided an update on the East Mesa ADMP, providing maps of the alternatives for the SR 24, Ellsworth and Rittenhouse systems as well as corridor data and draft cross sections of proposed facilities. She reviewed the progress the study had been making, including meetings with key stakeholders. Jen noted that the Arizona State Land Department, a primary land holder in the study area, has articulated the desire for a facility with the smallest footprint. She also reported that initial feedback from the public indicated the desire for a facility that was multi-use, specifically continuing to support activities such as horse riding and hiking.

Jen reported that coordination with the Germann Road and Meridian Road PARA studies, as well as outreach with stakeholders, continues and, because of the desire to



reach consensus on a coordinated facility, the study timeline has been extended until summer of 2013, with another round of public outreach intended to be hosted in late January 2013 to get feedback on preferred alternative(s).

### **3. Meridian Road Corridor Study**

Mr. Sabatini provided an update on the project, handing out maps of the corridor, future land use, current land ownership, and Baseline alternative alignment. While project coordination has been a priority, Mr. Sabatini noted that particular to the Meridian Road Corridor Study, a desire to share right of way for the future roadway corridor and flood control infrastructure was sought, as the two facilities combined could require upwards of 260-feet of right of way.

Regarding the Baseline alignment, Tim Oliver, MCDOT, noted that the study team should be sensitive to fissures in the area and existing property owners. Further discussion occurred, noting that the Baseline alignment will be impacted by the future configuration of the US 60/Meridian Road traffic interchange (TI), currently in study.

Charla Glendening, ADOT project manager, underscored that, as part of the Meridian Road Corridor Study, a desired product would be a memorandum of understanding (MOU) to memorialize the corridor's future functional classification, cross section and configuration, including how a flood control infrastructure would be integrated.

### **4. Discussion**

Discussion ensued regarding coordination of the facilities. Following highlights that discussion and areas of consensus that were reached:

- Arizona State Land Department would prefer to keep the flood control facility adjacent to the roadway facility and would not favor a channel that meanders or jogs away from the roadway alignment
- Interest was articulated in evaluating how a flood control facility could be designed to handle built-environment off-site drainage from Pinal County (specifically related to future development on State Land)
- Consensus was reached that the Meridian Road alignment should be on section line
- Consensus was reached that the flood control facility (channel) should stay upstream (or east) of the Meridian Road corridor and that the Meridian Road Corridor Study can reference the forthcoming ADMP update to this point
- Consensus was reached that the combined footprint for the flood control and roadway facilities should be refined/reduced as much as possible

### **5. Next Steps**

It was determined that the FCDMC, Pinal County and Arizona State Land Department would meet to clarify the functionality of the facility to further inform potential alternatives. Subsequent to those meetings, FCDMC would continue coordination with the Meridian Road Corridor study team to design potential facility cross sections.



Meeting adjourned at 3:35 p.m.

**Meeting:** Meridian Road Corridor Technical Advisory Committee Meeting #3

**Location:** Queen Creek Library, Edward Abby Room  
21802 S Ellsworth Road, Queen Creek, AZ 85242

**Date:** February 26<sup>th</sup>, 2013

**Time:** 1:30 p.m.

**Attendance:** Michelle Green, Arizona State Land Department; Ken Hall, City of Mesa; Doug Hansen, Pinal County; Tim Oliver, MCDOT; Giao Pham, City of Apache Junction; Amy Ritz, ADOT Urban Project Management; Lars Jacoby, ADOT Community Relations; Simon Pratt, Michael Baker Corporation; Mike Sabatini, Michael Baker Corporation

**Handouts:** Agenda, Elliot Road Maintenance MOU

Meeting began at 1:40 p.m.

## 1. Introductions

Mike Sabatini, Michael Baker Corporation (Baker) Project Manager, provided a welcome and asked participants to introduce themselves.

## 2. Working Paper #2

Mike Sabatini reviewed that the purpose of the meeting is to present Working Paper #2, Evaluation Criteria and Plan for Improvements, and to review and address comments to finalize the report.

Simon Pratt, Baker Transportation Engineer, walked participants through the content of Working Paper #2. The following comments were provided:

- VIII. Evaluation Criteria: Need to add Stakeholder input as well as public acceptability to criteria.
- X. Baseline Roadway Alternative: Consider access to businesses along Meridian Road between US 60 and Baseline Road
- XVI. Exiting Right of Way: David Evans and Associates carried out research for Apache Junction to ascertain the current right of way status along Meridian Road between McDowell Road and Southern Avenue. However, there appears to be discrepancy in the dedicated right of way dedicated indicated in on the County Assessors maps. Mike

pointed out that the County Assessor is concern with ownership with regard to taxation and that the right of way may exists by easement rather than by deed. The public will have a right to use the road but there is an underlying property owner. Right of way requirements highlighted in the report were based on the information provided by David Evans for this section of the roadway. Further investigation will be necessary to ascertain actual status.

Gioa restated that this project has multi-jurisdictional stakeholders and that Apache Junction had been proactive to investigate the existing right of way status. He pointed out that if there was agreement by the various jurisdictions for the need to up-grade Meridian Road, then the City of Apache Junction would be seeking financial help to take this project forward in the future.

### 3. Public Outreach

- Survey invitation mailer was went out last week
- Business walk – planned for the next two weeks to hand deliver the information flier and to encourage businesses to take the on-line survey.
- Additional outreach to partner contacts
  - Distribution of fliers
  - Solicitation via partner communications (agency newsletters, social media, etc.)
- Planned participation in eventual Flood Control District of Maricopa County (FCDMC) open house Audra Koester Thomas, Partners for Strategic Action (PSA), has been working with Jen Pokorski, FCDMC, regarding the potential for the study team to attend a future public meeting regarding the East Mesa ADMP project. The meeting has been put back to the end of March beginning of April. If the date slips much further it may not be able to included information in the report.
- There are no other public meetings planned for this project.

### 4. Next Step

- Finalize comments on Working Paper #2
- Incorporate comments into Working Paper #2 and submit
- Present information to public (if meeting with FCDMC goes ahead)
- Incorporate public feedback into final report
- Corridor Management Memorandum of Understanding (M.O.U)
  - Meetings will be set up with each of the jurisdiction to go over the wording of a MOU. This could lay the groundwork for a formal Intergovernmental Agreement (IGA) for the communities to take forward in the future.

Meeting adjourned at 2:30 p.m.



**Baker**

**TO:**

Charla Glendenning	ADOT, Multimodal Planning Division
Lars Jacoby	ADOT, CCCP
Ralph Ellis	ADOT, Environmental
Thor Anderson	ADOT, Multimodal Planning Division
Doug Hanson	Pinal County
Andy Smith	Pinal County
Giao Pham	City of Apache Junction
Ken Hall	City of Mesa
Mark Griffin	CAAG
Bob Hazlett	Maricopa County Department of Transportation
Felicia Terry	Maricopa County Flood Control District
Jen Pokorski	Maricopa County Flood Control District
Tom Condit	Town of Queen Creek
Michelle Green	Arizona State Land Department
Audra Koester Thomas	Partners for Strategic Action

**From:**

Michael Sabatini  
Michael Baker Jr., Inc  
2929 North Central Avenue, Suite 800  
Phoenix, AZ 85012  
Phone: 602-798-7571  
Fax: 602-279-1411  
Email: [msabatini@mbakercorp.com](mailto:msabatini@mbakercorp.com)

**Reference: MERIDIAN ROAD CORRIDOR STUDY: GERMANN ROAD TO MCDOWELL BLVD  
Planning Assistance for Rural Areas (PARA)**

**Time/Place: Wednesday, November 14, 2012, 1:30 p.m.**

Queen Creek Library  
Edward Abby Room  
21802 S Ellsworth Road  
Queen Creek, Az 85242

**Purpose: Technical Advisory Committee Meeting #2**

A Meeting has been scheduled for the above referenced project at the time and place above. You are encouraged to attend this meeting and provide input for the project. Your attendance is appreciated, however, please send a representative if you cannot attend. Should you have any questions about this project please contact Michael Sabatini 602-798-7571 or Simon Pratt 602-798-7525.



## AGENDA

### MERIDIAN ROAD CORRIDOR STUDY: GERMANN ROAD TO MCDOWELL BLVD Planning Assistance for Rural Areas (PARA)

Subject: **Technical Advisory Committee Meeting #2**  
Location: Queen Creek Library  
Edward Abby Room

Date/Time: **Tuesday February 26<sup>th</sup>, 2013, 1:30 p.m.**

---

**1. Introductions**

**2. Meeting Purpose:**

The purpose of this meeting is to present to the TAC Working Paper #2 (Evaluation Criteria & Plan for Improvement) for the Meridian Road Corridor Study and review/address comments to finalize the report. The TAC will discuss the next stage of the study along with the Public Involvement Process.

**3. Working Paper #2 (Evaluation Criteria & Plan For Improvement):**

- Development of Alternatives
- Evaluation Criteria
- Recommendations
- Right of Way Requirements

**4. Public Outreach**

**5. Next Step**

**6. Open Discussion – Q & A**



# Meridian Road Corridor Study

Technical Advisory Committee  
Working Paper #2 Discussion  
February 26, 2013

# Today's Meeting

- Introduction
- Summary of Working Paper #2
- Public Involvement
- Next Steps
- Open Discussion



# Study Area

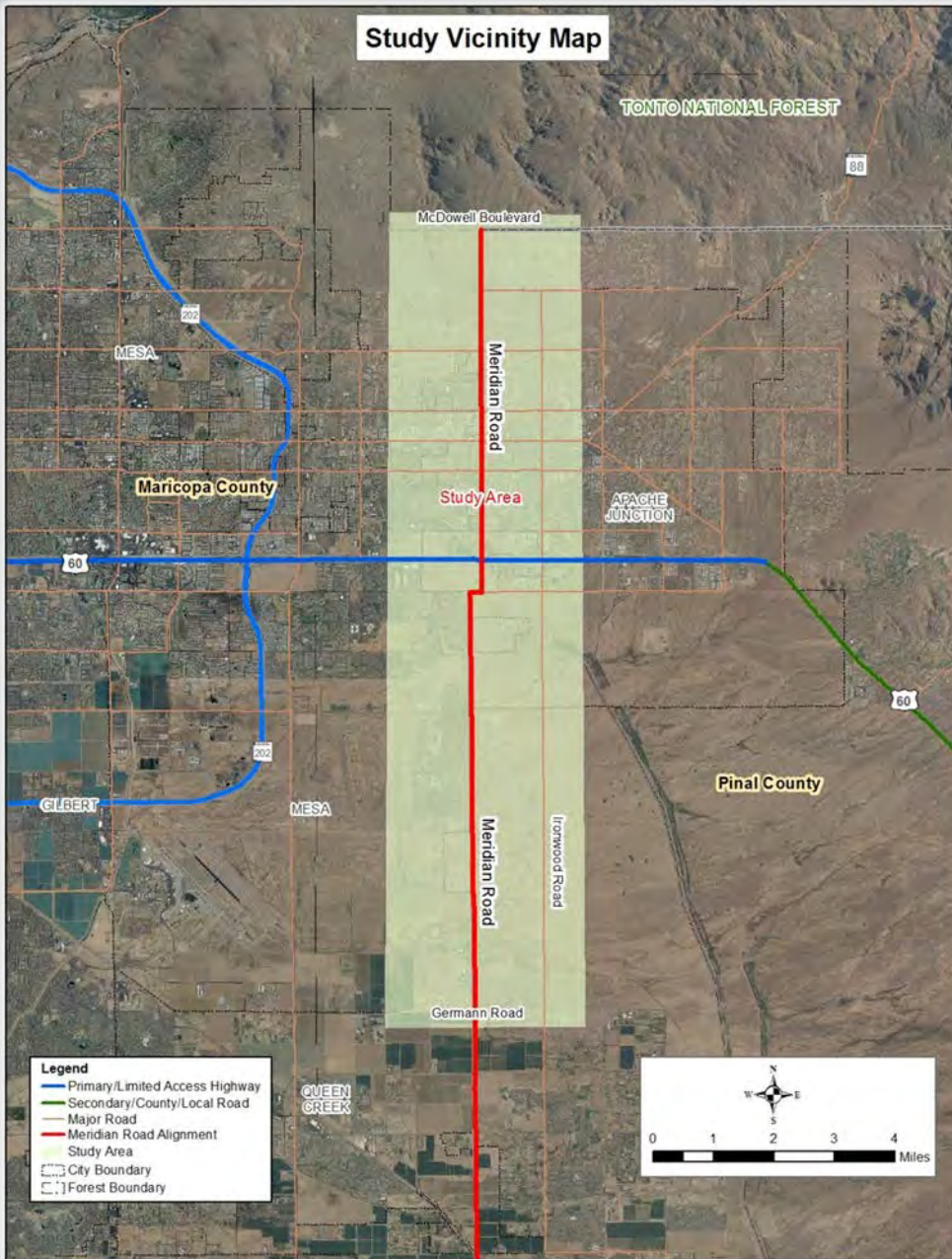

# Alternatives



- Northern Section – McDowell Boulevard to US 60
  - Lane Configuration
    - Roadway
    - Intersections
  - Right-of-way requirement
  
- Southern Section – US 60 to Germann Road
  - Lane Configuration
    - Roadway
    - Intersections
  - Alignment alternatives
  - Right-of-way requirement



# Traffic Volumes

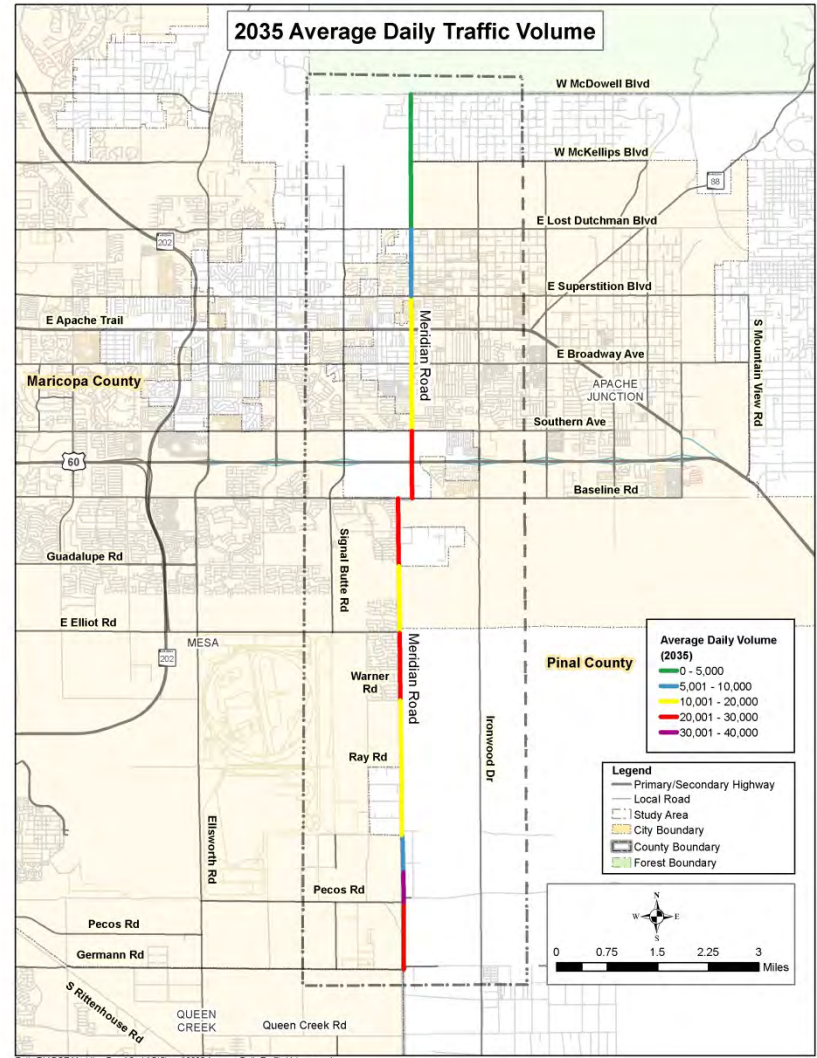
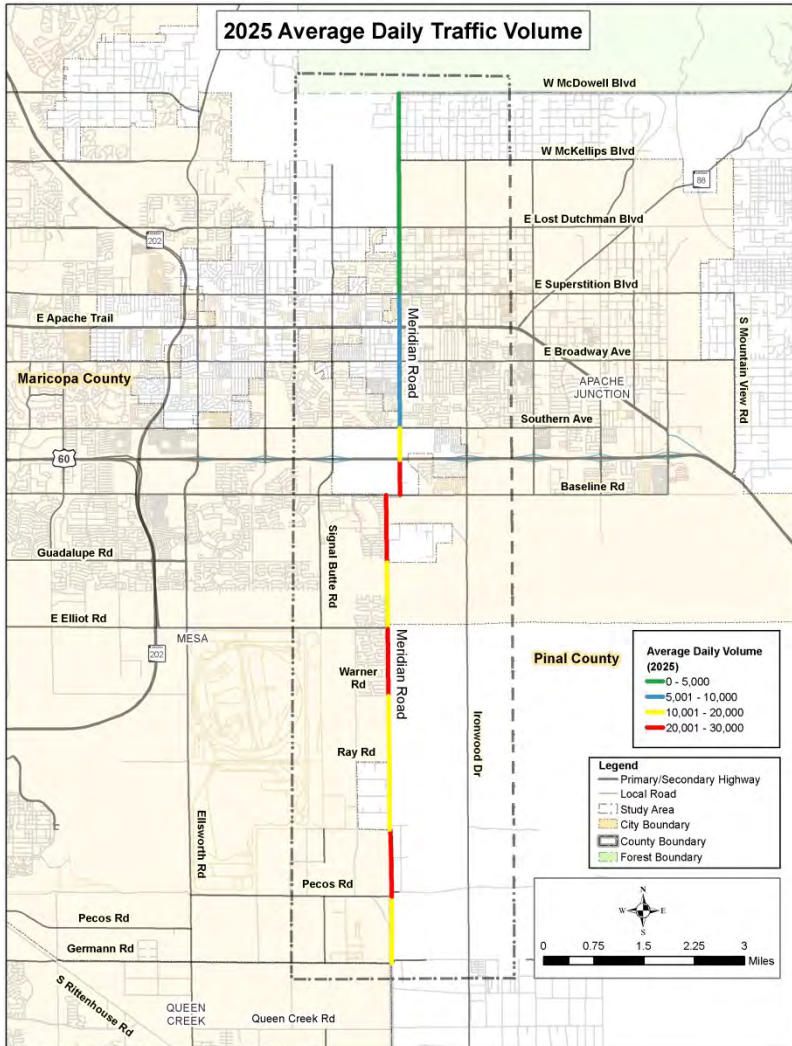

# Alternative Alignment



- Alternative 1 – No Build
- Alternative 2 – Section line alignment
- Alternative 3 – Off-set alignment
- Alternative 4 – Meandering alignment



# Alternative Alignment (cont.)

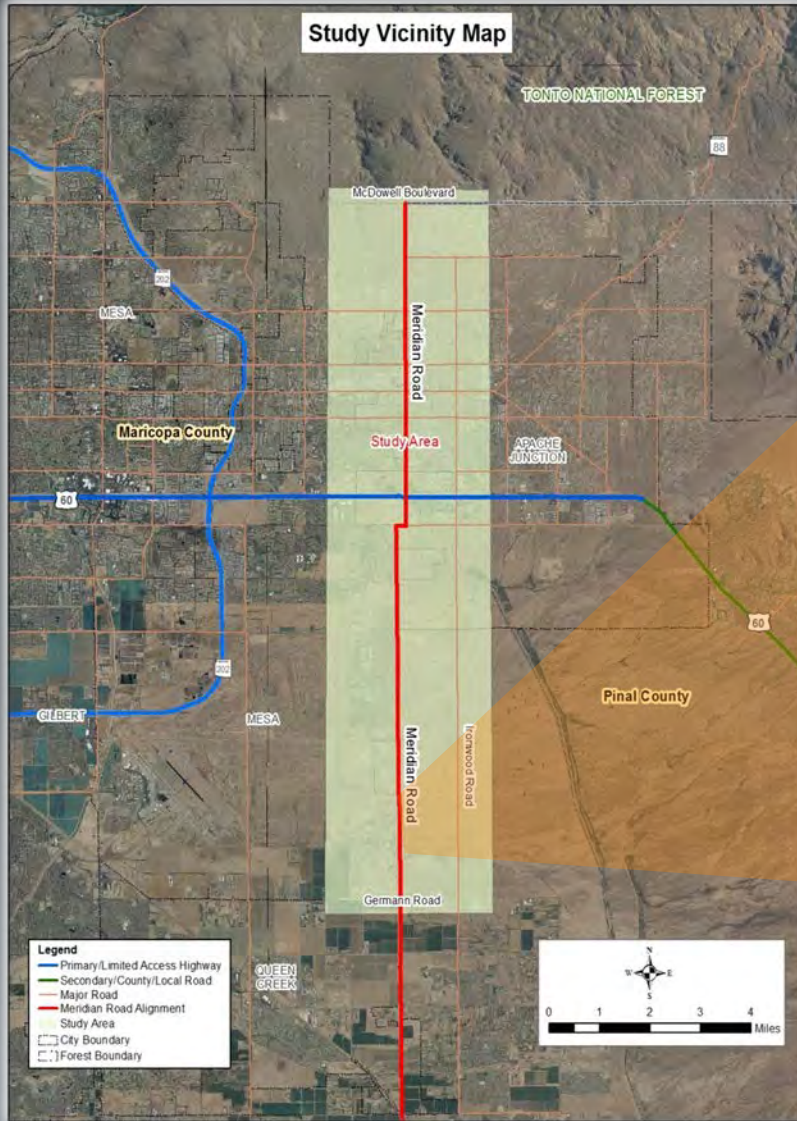

# Evaluation Criteria



- Constructability Issues
- Engineering Complexity
- Environmental/Cultural Issues
- Potential Utility Conflicts
- Traffic Operations
- Public Acceptability
- Socioeconomic Impacts

# Evaluation

Evaluation Criteria	Alternative Alternatives			
	Alt 1	Alt 2	Alt 3	Alt 4
Constructability Issues	○	○	○	○
Engineering Complexity	○	○	⊗	⊗
Environmental/Cultural Issues	○	○	○	○
Potential Utility Conflicts	○	⊗	●	⊗
Traffic Operations	●	○	○	○
Public Acceptability	●	⊗	⊗	○
Socioeconomic Impacts	○	⊗	○	⊗

- Minimal impact/high performance
- ⊗ Moderate impact/performance
- High impact/low performance



# Baseline Alternatives

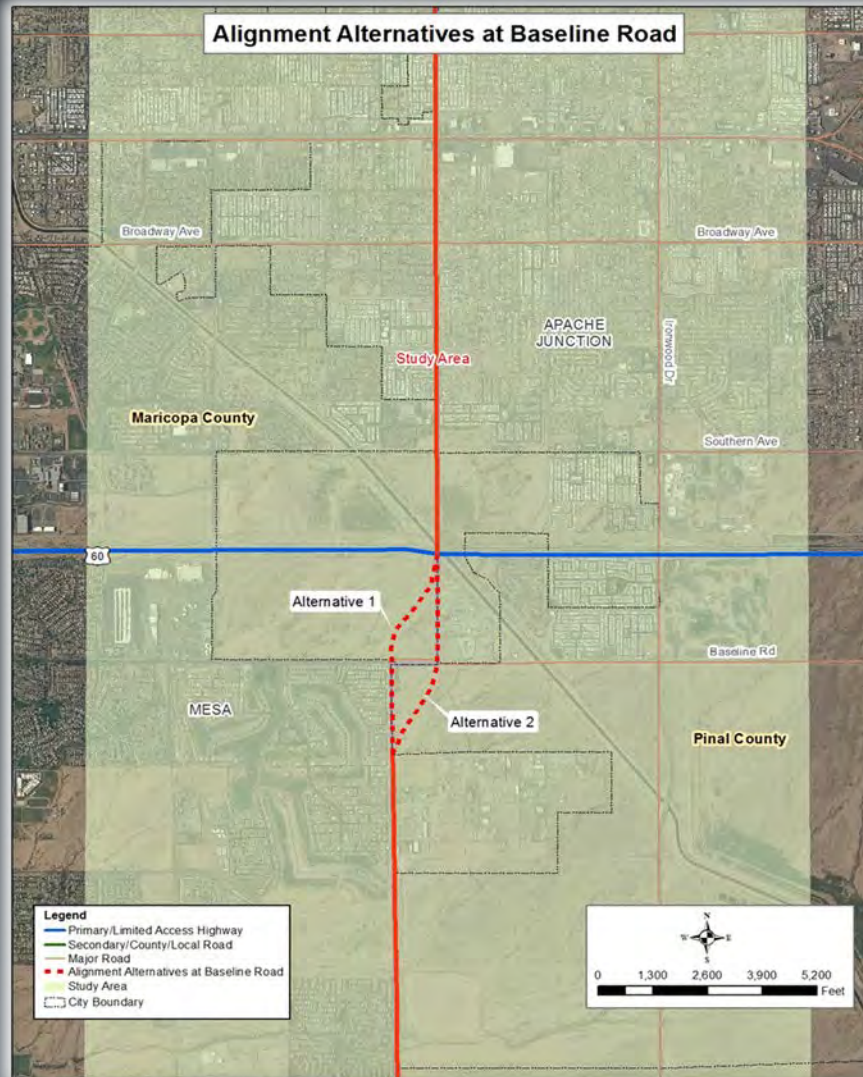

# Recommendations



- Near Term Improvements (2017)
  - US 60/Meridian Road Traffic Interchange
  - Southern Avenue/Meridian Road Signalized intersection
  - Extend Baseline Road to Elliott Road
- Mid-Term Improvements (2025)
  - Widen to three-lanes from Lost Dutchman Blvd to Southern Ave
  - Widen to four-lanes from Southern Ave to Elliot Road
  - Extend Meridian Road from Warner Rd to Germann Rd
- Long Term Improvements (2035)
  - Widen to four-lanes from Lost Dutchman Blvd to Southern Ave
  - SR 24/Meridian Road Interchange
- Ultimate Improvements (Beyond 2035)
  - Full six-lane cross section between Southern Avenue to Germann Road
  - Full interchange between US60/Meridian Road

# Interim Roadway Cross Sections

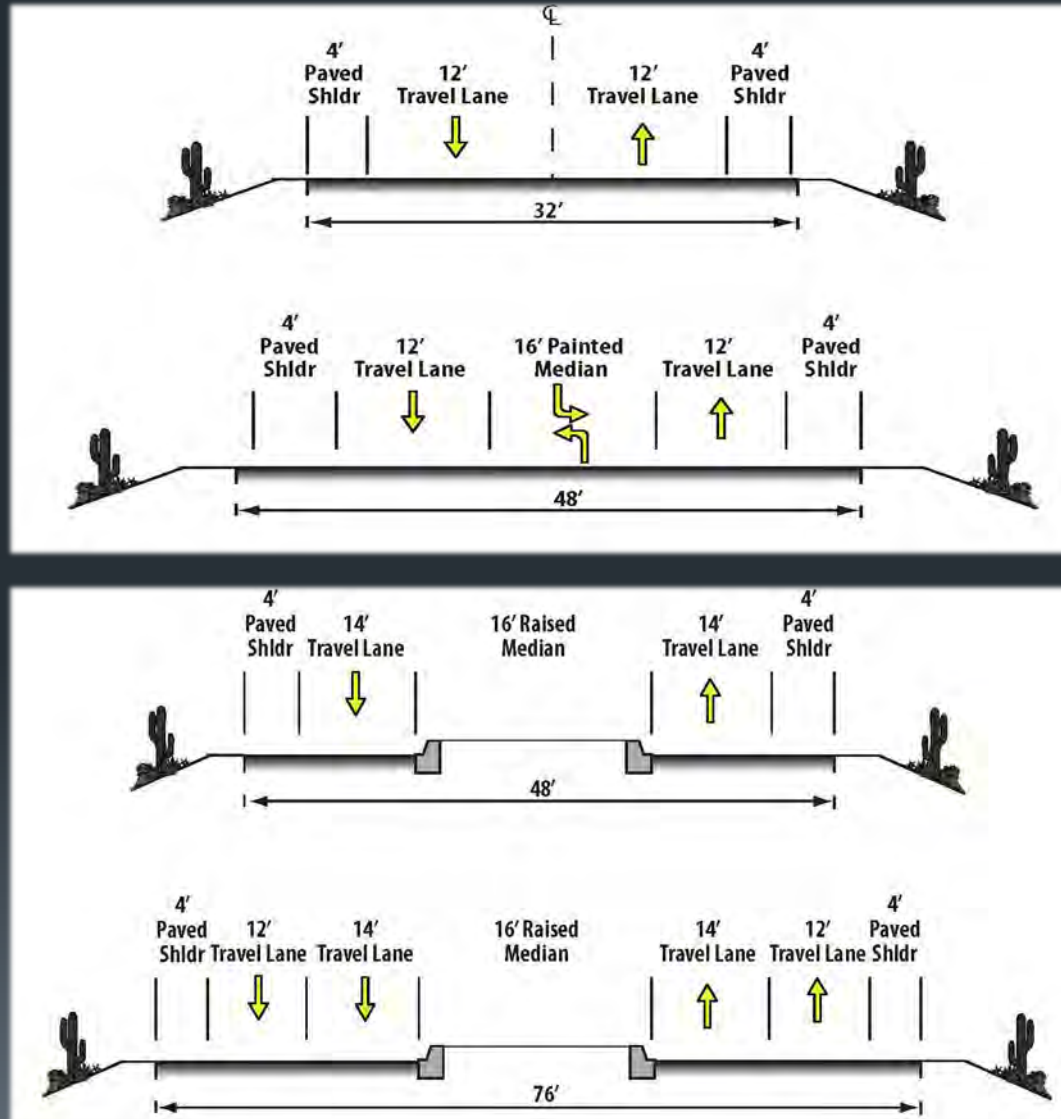

# Roadway Typical Section

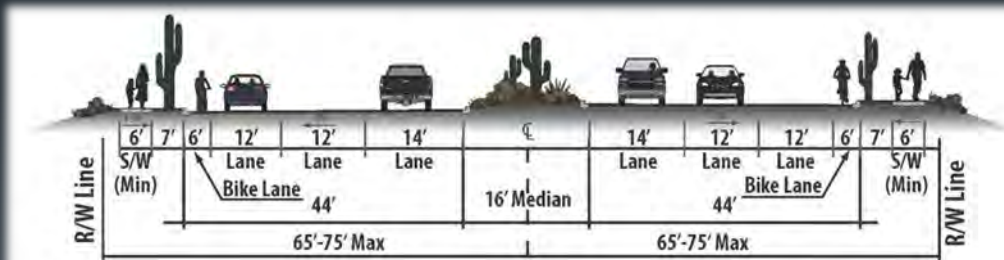
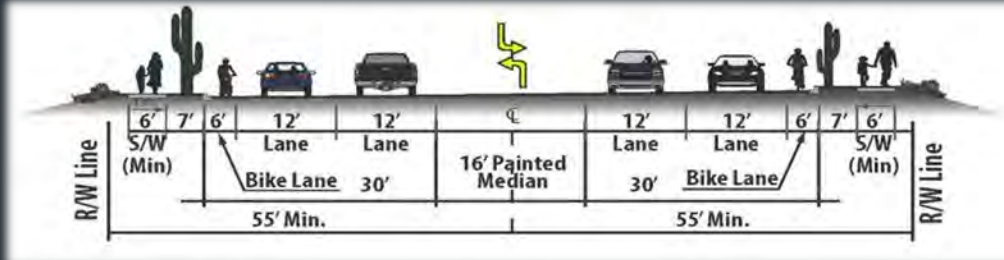
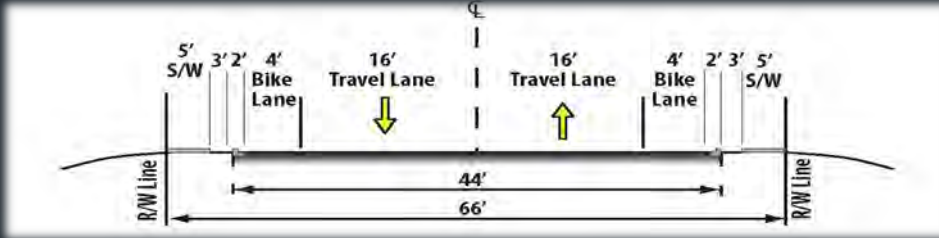

# Ultimate Four-Lane Cross Section

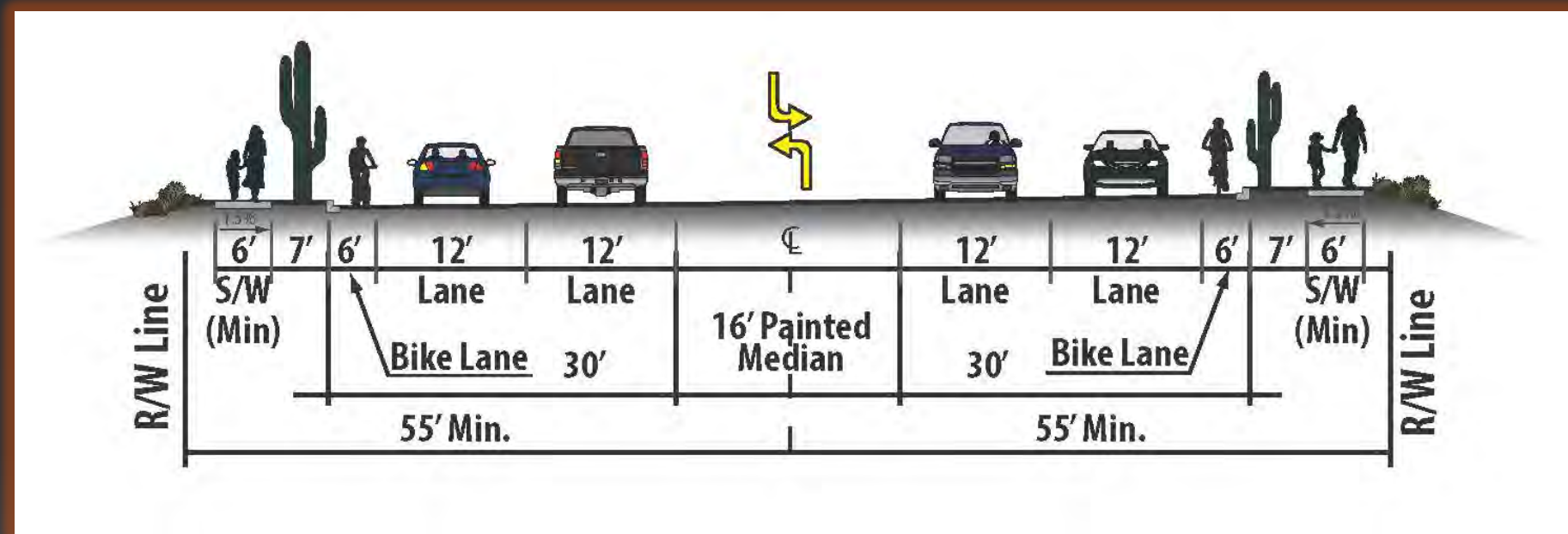



# Ultimate Six-Lane Cross Section

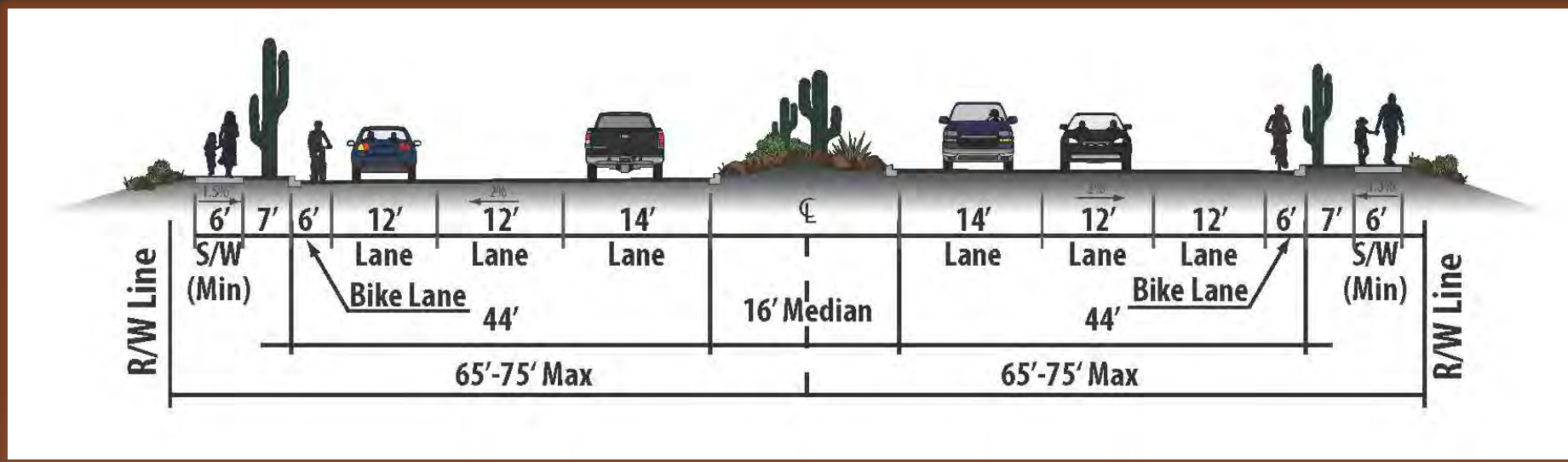





# Right of Way Requirements

Meridian Road Segments		ROW Width Required		Required Pavement Width
From	To	West of Centerline (MCDOT)	East of Centerline (PCDOT)	
McDowell Road	McKellips Boulevard	●None	●40'	●40'
McKellips Boulevard	Lost Dutchman Road	●None from McKellips to 1/2 mile south ●40' from 1/2 mile south of McKellips Blvd to Lost Dutchman	●40'	●40'
Lost Dutchman Road	Superstition Boulevard	●22' North of Smoketree Steet ●None South of Smoketree Street	●5' between Lost Dutchman Rd and Concho Street	●76'
			●22' between Concho Street and Teepee St	●72'
			●5' between Teepee St and Shiprock St	●72'
			●22' between Shiprock St and Silverado Estates	●72'
			●5' between Silverado Estates and Superstition Boulevard	●72'
Superstition Boulevard	Apache Trail	●None to 350' north of Apache Trail ●55' for 350' north of Apache Trail	●5' for a 300' segment south of Superstition Boulevard ●55' from 300' south of Superstition Boulevard to Gregory Street ●55' from Gregory St to Apache Trail	●76' ●76' ●76'
Apache Trail	Broadway Avenue	●55' from Apache Trail to 4th Street ●None from 4th St to 220' north of Broadway Road ●10' from 220' north of Broadway Rd to Broadway Rd	●15'	●76' ●76' ●76'
Broadway Avenue	Southern Avenue	●None North of Wier Ave ●55' South of Wier Ave to Pueblo Ave ●None between Pueblo Ave to Southern Ave	●55' Broadway Ave to 9th place ●5' from 9th Place to 16th Avenue ●22' from 16th Avenue for 1/4 mile ●5' from 1/4 mile south of 16th Street to Southern Avenue	●76'
Southern Avenue	Baseline Road	●10'	●15'	●104'
Baseline Road	Guadalupe Road	●None	●65'	●104'
Guadalupe Road	Elliot Road	●None except for a 1/2 mile section south of Guadalupe Road where 10' is required	●65'	●104'
Elliot Road	Warner Road	●None except for a 1/4 mile section south of Mesquite St where 10' is required	●65'	●104'
Warner Road	Ray Road	●10' from Warner Rd to Starkey Ave ●None from Starke Ave to Ray Rd	●65'	●104'
Ray Road	Williams Field Road	●None	●65'	●104'
Williams Field Road	Pecos Road	●10'	●65'	●104'
Pecos Road	Germann Road	●None	●65'	●104'

# Other Considerations



- Multi-Modal Considerations
  - Bicycle/Pedestrian
  - Sidewalks/Multi-use path
  - Transit
- Access Management
- Environment



# Public Outreach



- Public Outreach Update
  - Survey invitation mailer
  - Business walk
  - Additional outreach to partner contacts
    - Distribution of fliers
    - Solicitation via partner communications (agency newsletters, social media, etc.)
  - Planned participation in eventual FCDMC open house

# Next Step



- Finalize comments on Working Paper #2
- Incorporate comments into Working Paper #2 and submit
- Present information to public
- Incorporate public feedback into final report
- Corridor Management Memorandum of Understanding (M.O.U)

# Open Discussion |



Thank You

**MEMORANDUM OF UNDERSTANDING  
BETWEEN MARICOPA COUNTY AND THE  
CITY OF MESA FOR PLAN REVIEW, PLAN APPROVAL, PERMITTING,  
INSPECTION, CONSTRUCTION, ANNEXATION, OPERATION AND  
MAINTENANCE OF ELLIOT ROAD FROM POWER ROAD TO  
MERIDIAN ROAD**

**Project:**

The Elliot Road Corridor Study is an approximately eight (8) mile study from Power Road east to the Central Arizona Canal (CAP). The purpose of the study is to develop a consensus-driven vision for the Elliot Road Corridor, identify corridor deficiencies and requirements, and generate technically feasible alternatives designed to meet the established needs.

**Purpose:**

The purpose of this Memorandum of Understanding (MOU) is to establish design guidelines for Elliot Road from Power Road to Meridian Road and to outline the mutual understanding of Maricopa County (County) and the City of Mesa (City) regarding their respective roles for plan review, plan approval, permitting, inspection, construction, annexation, operation and maintenance of Elliot Road from Power Road to Meridian Road as defined in the Corridor Study completed by MCDOT in 2008. This MOU does not apply to sections of Elliot Road located between Power Road and Meridian Road that already exist within the jurisdiction of the City of Mesa.

**Background:**

In July 2007, Maricopa County Department of Transportation (MCDOT) kicked off the Elliot Road Corridor Study in the East Valley from Power Road to the Central Arizona Canal (CAP). As part of the completion of this study, the project team agreed that the portion of Elliot Road in Mesa's Metropolitan Planning Area (MPA) from Power Road to Meridian Road would be planned using the City's design standards. This MOU is being put together to define Maricopa County's (County) and Mesa's (City) respective roles to ensure that this is carried out by all applicable agencies.

**Project Guidelines:**

Road design and access guidelines for Elliot Road from Power Road to Meridian Road will follow the City Of Mesa design standards. Following a preliminary review by the City, the Maricopa County Development Services staff will review all plans for this section of Elliot Road against Mesa standards to ensure compliance with the



expectation that the City will annex the road within a reasonable time frame after construction is completed.

### **Responsibility of the County:**

1. The County shall review plans and specifications for projects submitted on Elliot Road between Power Road and Meridian Road after the City has indicated preliminary approval.
2. The County reserves the right to require any design modifications of the City standards which are deemed necessary for the operational safety or maintenance of the roadway.
3. The County shall provide final plan approval, issue right-of-way permits and shall be entitled to collect and retain any fees normally charged of developers for such services.
4. The County shall inspect any projects for compliance with approved plans and be responsible for construction acceptance and permit release.
5. The County will not accept construction or release the permit without written documentation that the City is satisfied.
6. The County shall be responsible for operation and maintenance of the roadway until the City annexes the projects.

### **Responsibility of the City of Mesa:**

1. The City shall review plans and specifications and provide comments regarding City design standards for any project that happens along Elliot Road between Power Road and Meridian Road that are under County jurisdiction at the time the plans are submitted for review.
2. The City shall coordinate with the County for the inspection of all Elliot Road development projects within County jurisdiction between Power Road and Meridian Road for compliance with approved plans.
3. The City shall move forward with the annexation of developed portions of Elliot Road with the anticipation that the annexation will be completed within six months after the improvements have been made, unless both the County and the City of Mesa agree that the annexation does not make sense at the time due to the limited size of improvements.
4. The City shall assume responsibility for the operation and maintenance within this Project area once the subsequent annexation has been completed.
5. The City shall assume immediate responsibility of all street lighting once it is operational.

**Effect of the MOU:**

The intent of this MOU is to clarify the goals and objectives of both the City and the County for Elliot Road between Power Road and Meridian Road. It does not obligate the County or the City to expend any funds or take any actions to complete any projects along this section of Elliot Road. This MOU serves as a temporary arrangement pending the possible annexation of Elliot Road by the City.

**Term of MOU:**

This MOU shall be in effect from the date of the last person to sign this MOU until the effective date of City's annexation of Elliot Road.

If these points are consistent with your understanding of previous discussions, please show your concurrence by signing below.

**Maricopa County, A Political  
Subdivision of the State of Arizona**

**City of Mesa, An Arizona  
Municipal Corporation**

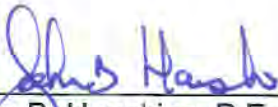
By:  7-22-08  
John B. Hauskins, P.E. Date  
MCDOT Transportation Director

By:  8-6-08  
Jack Friedline Date  
Deputy City Manager

# APPENDIX F

## PLANNING/ENVIRONMENTAL LINKAGES QUESTIONNAIRE

**Baker**

**Michael Baker Jr., Inc.**  
*Phoenix, Arizona*

## QUESTIONNAIRE FOR TRANSPORTATION PLANNERS – PART 1

This part of the questionnaire should be completed by transportation planners at the beginning of the transportation planning study. Please note that planners should also review the second part of the questionnaire to understand what additional issues will need to be considered and documented as the study progresses.

1.1 Project identification		
<i>What is the name of the study? What cities and region does it cover? What major streets are covered? For corridor studies, what are the intended termini?</i>		
Meridian Road Corridor Study: Project extends from McDowell Blvd in the north to Germann Road in the south. The project passes through the City of Apache Junction, Pinal County, Maricopa County, and the City of Mesa		
<i>Who is the study sponsor?</i>		
ADOT Multimodal Planning Division as a request from Pinal County and the City of Apache Junction through the PARA Study process.		
<i>Briefly describe the study and its purpose.</i>		
The principal focus of this study is to address the transportation planning needs identified by the jurisdictions to develop consensus on facility type, number of lanes and right-of-way requirements to guide the future development of the road.		
<i>Who are the primary study team members (include name, title, organization name, and contact information)?</i>		
Charla Glendening Project Manager ADOT Multimodal Planning Division 206 S. 17th Avenue, Mail Drop 301B Phoenix, AZ 85007	Giao Pham Public Works Director City of Apache Junction 575 E. Baseline Avenues Apache Junction, AZ 85219	Doug Hansen Planning Section Chief Public Works Department Pinal County 31 N. Pinal Street, Building F P.O Box 727, Florence, AZ 85132
<i>Does the team include advisory groups such as a technical advisory committee, steering committee, or other? If so, include roster(s) as attachment(s).</i>		
Technical Advisory Committee (See attached)		
<i>Have previous transportation planning studies been conducted for this region? If so, provide a brief chronology, including the years the studies were completed. Provide contact names and locations of the studies and study websites.</i>		
See attached summary table of previous studies		
<i>What current or near-future planning (or other) studies in the vicinity are underway or will be undertaken? What is the relationship of this study to those studies? Provide contact names and locations of the studies and study websites.</i>		
ADOT North- South Corridor Study ( <a href="http://www.azdot.gov/northsouthcorridorstudy/">http://www.azdot.gov/northsouthcorridorstudy/</a> ). This project will have a big influence on the future development of the area to the west of Meridian Road and future traffic growth; ADOT US 60 Crimson Road to Meridian Road. This study will determine the location and configuration of a future traffic Interchange between US 60 and Meridian Road.; FCDMC East Mesa ADMP ( <a href="http://www.fcd.maricopa.gov/Projects/PPM/projStructDetails.aspx?ProjectID=223">http://www.fcd.maricopa.gov/Projects/PPM/projStructDetails.aspx?ProjectID=223</a> ). This study will determine the location of drainage channels which potentially could be adjacent to roadway and could share right of way with Meridian Road.; ADOT Passenger Rail Corridor Study ( <a href="http://www.azdot.gov/passengerrail/">http://www.azdot.gov/passengerrail/</a> ) One of the rail route options crosses Meridian Road north of SR 24 and location of station within Superstation Vistas will be a traffic generator.		
1.2 Study objectives		
What are your desired outcomes for this study? (Mark all that apply.)		
<input checked="" type="checkbox"/> Stakeholder identification <input checked="" type="checkbox"/> Stakeholder roles/responsibilities definition <input checked="" type="checkbox"/> Travel study area definition <input type="checkbox"/> Performance measures development <input checked="" type="checkbox"/> Development of purpose and need goals and other objectives <input checked="" type="checkbox"/> Alternative evaluation and screening <input type="checkbox"/> Alternative travel modes definition	<input checked="" type="checkbox"/> Scheduling of infrastructure improvements over short-, mid-, and long-range time frames <input checked="" type="checkbox"/> Environmental impacts <input type="checkbox"/> Mitigation identification <input type="checkbox"/> Don't know <input checked="" type="checkbox"/> Other: Preserve ability for federal funding and develop consensus for facility type, number of lanes and right of way requirements.	
<i>Have system improvements and additions that address your transportation need been identified in a fiscally constrained regional transportation plan?</i>		
Yes – Maricopa Association of Governments 'Regional Transportation Plan'; Pinal County's 'Regional Significant Route For Safety and Mobility Plan'		

<i>Will a purpose and need statement<sup>1</sup> be prepared as part of this effort? If so, what steps will need to be taken during the NEPA process to make this a project-level purpose and need statement?</i>
A purpose and need statement will form part of the report, this will be developed further in the NEPA process when a formal Environmental Assessment is carried out.
<b>1.3 Establishment of organizational relationships</b>
<i>Is a partnering agreement in place? If so, who are signatories (for example, affected agencies, stakeholders, organizations)? Attach the partnering agreement(s).</i>
No agreement is in place. The project is expected to develop a Memorandum of Understanding to be agreed and signed by the City of Apache Junction, Pinal County, Maricopa County, City of Mesa and the Town of Queen Creek
<i>What are the key coordination points in the decision-making process?</i>
Agreement on existing and future conditions within project area. Alternative development and analysis of recommended alternatives. Agreement on typical roadway section and right-of-way requirements. Agreement of MOU. Coordination established through TAC meeting and one to one meetings.
<b>1.4 Planning assumptions and analytical methods</b>
<i>Is the time horizon of the study sufficiently long to consider long-term (20 years or more from completion of the study) effects of potential scenarios?</i>
Yes, the study will evaluate existing, short-range (2015-2020), and long-range (2030-2035) conditions.
<i>What method will be used for forecasting traffic volumes (for example, traffic modeling or growth projections)? What are the sources of data being used? Has USDOT validated their use?</i>
Traffic figures are to obtain from MAG travel demand model and compare with previous studies such as MCDOT corridor study and Apache Junction Transportation study. MAG model has been validated by USDOT.
<i>Will the study use FHWA's Guide on the Consistent Application of Traffic Analysis Tools and Methods<sup>2</sup>? If not, why not? How will traffic volumes from the travel demand model be incorporated, if necessary, into finer-scale applications such as a corridor study?</i>
Yes – Synchro traffic operation analysis. The team will use agency model forecasts. The methods and tools will be reviewed with the PMT.
<i>Do the travel demand models base their projections on differentiations between vehicles?</i>
Yes. The model predicts personal vehicles and commercial vehicles (light or heavy trucks).
<b>1.5 Data, information, and tools</b>
<i>Is there a centralized database or website that all State resource agencies may use to share resource data during the study?</i>
Yes - <a href="http://mpd.azdot.gov/MPD/Systems_Planning/meridian.asp">http://mpd.azdot.gov/MPD/Systems_Planning/meridian.asp</a>

<sup>1</sup> For an explanation of purpose and need in environmental documents, please see the Federal Highway Administration's (FHWA's) "NEPA and Transportation Decisionmaking: The Importance of Purpose and Need in Environmental Documents," <[Purpose and Need](#)>. This website provides links to five additional resources and guidance from FHWA that should be helpful in understanding the relationship between goals and objectives in transportation planning studies and purpose and need statements of NEPA documents.

<sup>2</sup> FHWA November 2011 publication: <[Traffic Analysis Tools and Methods](#)>



## Questionnaire for Transportation Planners – Part 2

This part of the questionnaire should be completed by transportation planners at the end of the transportation planning study. This completed document should become an appendix to the study's final report to document how the study meets the requirements of 23 Code of Federal Regulations § 450.212 or § 450.318.

2.1 Purpose and need for this study
<i>How did the study process define and clarify corridor-level or subarea-level goals (if applicable) that influenced modal infrastructure improvements and/or the range of reasonable alternatives?</i>
<p>The Study evaluated improvements based on goals developed with input from the Technical Advisory Committee. The overall goals and objectives for the Corridor study area were to develop consensus on:</p> <ul style="list-style-type: none"> <li>• Facility type</li> <li>• Number of lanes</li> <li>• Right-of-way requirements to guide the future development of the road.</li> <li>• Memorandum of Opportunity (MOU) on how the agencies will cooperate in the future as the area/corridor develops</li> </ul>
<i>What were the key steps and coordination points in the decision-making process? Who were the decision-makers and who else participated in those key steps?</i>
<p>Coordination points for the project included: Scoping process with stakeholders</p> <ul style="list-style-type: none"> <li>• Four TAC meetings (Work Plan, Current and Future Conditions, Plan for Improvements and Draft Final Report)</li> <li>• Identifying project stakeholders, and determining list of stakeholders for focus interviews</li> <li>• Agreement on traffic forecast methodology using Maricopa Association of Governments and ADOT forecasts</li> <li>• Public meeting in Queen Creek on May 16th 2013</li> <li>• Coordinated with the Flood Control District of Maricopa County and Arizona State Land Department regarding development of East Mesa ADMIP</li> </ul> <p>The TAC (as identified on page 15) was the decision makers for the project. Resource and regulatory agencies were contacted during the study for input.</p>
<i>How should this study information be presented in future NEPA document(s), if applicable? Are relevant findings documented in a format and at a level of detail that will facilitate reference to and/or inclusion in subsequent NEPA document(s)?<sup>3</sup></i>
<p>The Meridian Road Corridor Study is documented in a format that will serve as a reference or supporting document; the document identifies environmental issues in the corridor. The purpose and need and reasonable range of alternatives can be utilized in a subsequent document.</p>
<i>Were the study's findings and recommendations documented in such a way as to facilitate an FHWA or Federal Transit Administration decision regarding acceptability for application in the NEPA process? Does the study have logical points where decisions were made and where concurrence from resource or regulatory agencies, stakeholders, and the public was sought? If so, provide a list of those points.</i>
<p>FHWA 's Ed Stillings, was part of the TAC team who discussed how the study should be implemented and how PEL should be incorporated. Decisions were made by the TAC team which is composed of a variety of stakeholders.</p> <p>Study findings and recommendations were acceptable to agencies and are well documented in the Study.</p> <p>The public and stakeholder outreach is documented in the Public Involvement Summary Report (incorporated by reference); a public meeting was held in Queen Creek, Pinal County, Arizona, on May 16th, 2013.</p> <p>The study involved coordination and interviews with agencies identifying issues and understanding needs and concerns in the corridor (rather than concurrence).</p>

<sup>3</sup> For an explanation of the types of documents needed under the NEPA process and the nature of the content of those documents, please see "NEPA Documentation: Improving the Quality of Environmental Documents," <[Documentation](#)>.

2.2 Establishment of organizational relationships – tribes and agencies <sup>4</sup>			
Tribe or agency	Date(s) contacted	Describe level of participation	Describe the agency's primary concerns and the steps needed to coordinate with the agency during NEPA scoping. <sup>5</sup>
<b><i>Tribal</i></b>			
Salt River Pima-Maricopa Indian Community	November 9th 2012	Stakeholder	None identified
Fort McDowell Indian Community	November 9th 2012	Stakeholder	None identified
Gila River Indian Community	November 9th 2012	Stakeholder	None identified
Ak-Chin Indian Community	November 9th 2012	Stakeholder	None identified
<b><i>Federal</i></b>			
Bureau of Land Management	November 9th 2012	Stakeholder	None identified
Bureau of Reclamation	November 9th 2012	Stakeholder	None identified
Federal Highway Administration	Throughout Study	Technical Advisory Committee	Refer to meeting notes in appendices of final report
U.S. Environmental Protection Agency	November 9th 2012	Stakeholder	None identified
U.S. Fish and Wildlife Service	November 9th 2012	Stakeholder	None identified
Other			
<b><i>State</i></b>			
Arizona Department of Environmental Quality	November 9th 2012	Stakeholder	None identified
Arizona Game and Fish Department	November 9 <sup>th</sup> 2012	Stakeholder	None identified
Arizona State Land Department	Throughout Study	Technical Advisory Committee	Refer to meeting notes in appendices of final report
Other			
<b><i>County</i></b>			
Maricopa County	Throughout Study	Technical Advisory Committee	Refer to meeting notes in appendices of final report
Pinal County	Throughout Study	Technical Advisory Committee	Refer to meeting notes in appendices of final report
Pinal County Floodplain Administration	November 9th 2012	Stakeholder	None identified
Flood Control District of Maricopa County	Throughout Study	Technical Advisory Committee	Refer to meeting notes in appendices of final report
<b><i>Local</i></b>			
Salt River Project Biological & Cultural Service	November 9th 2012	Stakeholder	None identified
Central Arizona Association of Governments	Throughout Study	Technical Advisory Committee	Refer to meeting notes in appendices of final report

<sup>4</sup> Users may add rows to this table to accommodate additional tribes and agencies. Unused rows may be deleted.

<sup>5</sup> If the transportation planning study final report does not adequately document interactions (for example, meeting minutes, resolutions, letters) with the relevant agencies, append such information to the end of this questionnaire and checklist.

2.2 Establishment of organizational relationships – tribes and agencies <sup>4</sup>			
Tribe or agency	Date(s) contacted	Describe level of participation	Describe the agency's primary concerns and the steps needed to coordinate with the agency during NEPA scoping. <sup>5</sup>
<b>Transportation Agencies</b>			
Phoenix-Mesa Gateway Airport	November 9th 2012	Stakeholder	None identified

2.3 Establishment of organizational relationships – stakeholders and members of the public <sup>6</sup>			
Public and stakeholders	Date(s) contacted	Describe level of participation	Describe the primary concerns expressed by members of the public and stakeholders.
<b>Public</b>			
Members of the public	Refer to Public Involvement Summary Report		
<b>Stakeholders</b>			
Other (for example, Audubon Society, Center for Biological Diversity, citizens groups, homeowners associations, Sierra Club, private mining or energy interests, railroad companies)	Refer to Public Involvement Summary Report		

2.4 Planning assumptions and analytical methods
<i>Did the study provide regional development and growth assumptions and analyses? If so, what were the sources of the demographic and employment trends and forecasts?</i>
Yes, the study used growth projections identified as part of the Maricopa Association of Governments (MAG) Travel Demand Model (TDM) socioeconomic projections (2009) and growth projection use in Apache Junction Comprehensive Transportation Study (2012).
<i>What were the future-year policy and/or data assumptions used in the transportation planning process related to land use, economic development, transportation costs, and network expansion?</i>
Traffic forecasts for the Study were derived from the MAG TDM and Apache Junction Comprehensive Transportation Study. As such, the planning assumptions inherent in that model were carried forward.
<i>Were the planning assumptions and the corridor vision/purpose and need statement consistent with each other and with the long-range transportation plan? Are the assumptions still valid?</i>
This study compiles planning assumptions of existing studies in the region including the MAG RTP, Apache Junction Transportation Plan, Superstition Vistas Pinal County Comprehensive Plan, Mesa Transportation Plan and the multimodal approach in the Statewide Long Range Transportation Plan.
2.5 Data, information, and tools
<i>Are the relevant data used in the study available in a compatible format that is readily usable? Are they available through a centralized web portal?</i>
Yes. <a href="http://mpd.azdot.gov/MPD/Systems_Planning/meridian.asp">http://mpd.azdot.gov/MPD/Systems_Planning/meridian.asp</a> .
<i>Are the completeness and quality of the data consistent with the quality (not scale or detail) of inputs needed for a NEPA project-level analysis??</i>
Yes, but given the long-range nature of the Study, updates will be necessary during project(s) development. The completeness and quality are appropriate for a corridor study. Project level analysis will follow in future DCR and scoping efforts.

<sup>6</sup> Users may add rows to this table to accommodate additional stakeholders.

<sup>7</sup> For an explanation of the types of information needed to evaluate impacts in environmental documents, please see FHWA's "NEPA and Transportation Decisionmaking: Impacts," <[Analysis of Impacts](#)>. This website provides links to six additional resources and guidance that should be helpful in understanding the types of impacts that need to be assessed, their context, and their intensity.

<b>2.5 Data, information, and tools</b>
<i>Are the data used in the study regularly updated and augmented? If regularly updated, provide schedule and accessibility information.</i>
MAG updates traffic and socioeconomic data regularly (updates to the socioeconomic projections are expected in the later part of 2013).
<i>Have the environmental data been mapped at scales that facilitate comparison of effects across different resources and at sufficient resolution to guide initial NEPA issue definition? If not, what data collection and/or manipulation would likely be needed for application to the NEPA scoping process?</i>
Initial data has been collected of the different resources needed to develop this long-range study. Additional data collection will be necessary for environmental considerations such as water quality, biology, cultural resources and wildlife corridor evaluation.

Examine the Checklist for Environmental Planners, at the back of this document, for more detail about potential impacts that could be mapped. Below is an abbreviated list of resources that could occur in the study area and may be knowable at this time and at the study's various analytical scales:

Resource or issue	Is the resource or issue present in the area?	Would any future transportation policies or projects involve the issue? Would there be impacts on the resource?	Resource or issue	Is the resource or issue present in the area?	Would any future transportation policies or projects involve the issue? Would there be impacts on the resource?
Sensitive biological resources	<input type="checkbox"/> Yes <input checked="" type="checkbox"/> No <input type="checkbox"/> Unknown <input type="checkbox"/> Not applicable	<input type="checkbox"/> Yes <input checked="" type="checkbox"/> No <input type="checkbox"/> Unknown <input type="checkbox"/> Not applicable	Section 4(f) <sup>8</sup> wildlife and/or waterfowl refuge, historic site, recreational site, park	<input checked="" type="checkbox"/> Yes <input type="checkbox"/> No <input type="checkbox"/> Unknown <input type="checkbox"/> Not applicable	<input checked="" type="checkbox"/> Yes <input type="checkbox"/> No <input type="checkbox"/> Unknown <input type="checkbox"/> Not applicable
Wildlife corridors	<input type="checkbox"/> Yes <input checked="" type="checkbox"/> No <input type="checkbox"/> Unknown <input type="checkbox"/> Not applicable	<input type="checkbox"/> Yes <input checked="" type="checkbox"/> No <input type="checkbox"/> Unknown <input type="checkbox"/> Not applicable	Section 6(f) <sup>9</sup> resource	<input type="checkbox"/> Yes <input type="checkbox"/> No <input checked="" type="checkbox"/> Unknown <input type="checkbox"/> Not applicable	<input type="checkbox"/> Yes <input type="checkbox"/> No <input checked="" type="checkbox"/> Unknown <input type="checkbox"/> Not applicable
Wetland areas	<input type="checkbox"/> Yes <input checked="" type="checkbox"/> No <input type="checkbox"/> Unknown <input type="checkbox"/> Not applicable	<input type="checkbox"/> Yes <input checked="" type="checkbox"/> No <input type="checkbox"/> Unknown <input type="checkbox"/> Not applicable	Existing development	<input checked="" type="checkbox"/> Yes <input type="checkbox"/> No <input type="checkbox"/> Unknown <input type="checkbox"/> Not applicable	<input checked="" type="checkbox"/> Yes <input type="checkbox"/> No <input type="checkbox"/> Unknown <input type="checkbox"/> Not applicable
Riparian areas	<input type="checkbox"/> Yes <input type="checkbox"/> No <input checked="" type="checkbox"/> Unknown <input type="checkbox"/> Not applicable	<input type="checkbox"/> Yes <input type="checkbox"/> No <input checked="" type="checkbox"/> Unknown <input type="checkbox"/> Not applicable	Planned development	<input checked="" type="checkbox"/> Yes <input type="checkbox"/> No <input type="checkbox"/> Unknown <input type="checkbox"/> Not applicable	<input checked="" type="checkbox"/> Yes <input type="checkbox"/> No <input type="checkbox"/> Unknown <input type="checkbox"/> Not applicable
100-year floodplain	<input checked="" type="checkbox"/> Yes <input type="checkbox"/> No <input type="checkbox"/> Unknown <input type="checkbox"/> Not applicable	<input checked="" type="checkbox"/> Yes <input type="checkbox"/> No <input type="checkbox"/> Unknown <input type="checkbox"/> Not applicable	Title VI/ Environmental justice populations <sup>10</sup>	<input checked="" type="checkbox"/> Yes <input type="checkbox"/> No <input type="checkbox"/> Unknown <input type="checkbox"/> Not applicable	<input checked="" type="checkbox"/> Yes <input type="checkbox"/> No <input type="checkbox"/> Unknown <input type="checkbox"/> Not applicable
Prime or unique farmland or farmland of statewide or local importance	<input type="checkbox"/> Yes <input checked="" type="checkbox"/> No <input type="checkbox"/> Unknown <input type="checkbox"/> Not applicable	<input type="checkbox"/> Yes <input checked="" type="checkbox"/> No <input type="checkbox"/> Unknown <input type="checkbox"/> Not applicable	Utilities	<input checked="" type="checkbox"/> Yes <input type="checkbox"/> No <input type="checkbox"/> Unknown <input type="checkbox"/> Not applicable	<input checked="" type="checkbox"/> Yes <input type="checkbox"/> No <input type="checkbox"/> Unknown <input type="checkbox"/> Not applicable
Visual resources	<input type="checkbox"/> Yes <input checked="" type="checkbox"/> No <input type="checkbox"/> Unknown <input type="checkbox"/> Not applicable	<input type="checkbox"/> Yes <input checked="" type="checkbox"/> No <input type="checkbox"/> Unknown <input type="checkbox"/> Not applicable	Hazardous materials	<input checked="" type="checkbox"/> Yes <input type="checkbox"/> No <input type="checkbox"/> Unknown <input type="checkbox"/> Not applicable	<input checked="" type="checkbox"/> Yes <input type="checkbox"/> No <input type="checkbox"/> Unknown <input type="checkbox"/> Not applicable
Designated scenic road/byway	<input type="checkbox"/> Yes <input checked="" type="checkbox"/> No <input type="checkbox"/> Unknown <input type="checkbox"/> Not applicable	<input type="checkbox"/> Yes <input checked="" type="checkbox"/> No <input type="checkbox"/> Unknown <input type="checkbox"/> Not applicable	Sensitive noise receivers <sup>11</sup>	<input checked="" type="checkbox"/> Yes <input type="checkbox"/> No <input type="checkbox"/> Unknown <input type="checkbox"/> Not applicable	<input checked="" type="checkbox"/> Yes <input type="checkbox"/> No <input type="checkbox"/> Unknown <input type="checkbox"/> Not applicable
Archaeological resources	<input checked="" type="checkbox"/> Yes <input type="checkbox"/> No <input type="checkbox"/> Unknown <input type="checkbox"/> Not applicable	<input checked="" type="checkbox"/> Yes <input type="checkbox"/> No <input type="checkbox"/> Unknown <input type="checkbox"/> Not applicable	Air quality	<input checked="" type="checkbox"/> Yes <input type="checkbox"/> No <input type="checkbox"/> Unknown <input type="checkbox"/> Not applicable	<input checked="" type="checkbox"/> Yes <input type="checkbox"/> No <input type="checkbox"/> Unknown <input type="checkbox"/> Not applicable
Historical resources	<input type="checkbox"/> Yes <input checked="" type="checkbox"/> No <input type="checkbox"/> Unknown <input type="checkbox"/> Not applicable	<input type="checkbox"/> Yes <input checked="" type="checkbox"/> No <input type="checkbox"/> Unknown <input type="checkbox"/> Not applicable	Other (list) _____	<input type="checkbox"/> Yes <input type="checkbox"/> No <input type="checkbox"/> Unknown <input type="checkbox"/> Not applicable	<input type="checkbox"/> Yes <input type="checkbox"/> No <input type="checkbox"/> Unknown <input type="checkbox"/> Not applicable

<sup>8</sup> Section 4(f) of the U.S. Department of Transportation Act of 1966 (49 U.S. Code § 303, as amended); see <[Section 4\(f\)](#)>.

<sup>9</sup> Section 6(f) of the Land and Water Conservation Fund Act

<sup>10</sup> refers to Title VI of the 1964 Civil Rights Act and 1994 Executive Order 12898 on environmental justice

<sup>11</sup> under FHWA's Noise Abatement Criterion B: picnic areas, recreation areas, playgrounds, active sports areas, parks, residences, motels, hotels, schools, churches, libraries, and hospitals



<i>Did the study incorporate models of, for example, species/habitat locations (predictive range maps), future land use, population dynamics, stormwater runoff, or travel demand? What models were used? Did the study adequately document what models were used, who was responsible for their use, and how they were used (with respect to, for example, calibration, replicability, contingencies, and exogenous factors)?</i>
The Study utilized existing environmental, travel demand, and socio-economic data obtained from a variety of sources. The sources of this data were substantiated by the TAC as representing the best available information.
<i>In scoping, conducting, and documenting the planning study, participants have come across documents and leads from agency staff and other sources that the environmental planners may be able to use in conducting their studies. List any applicable memoranda of understanding, cost-share arrangements, programmatic agreements, or technical studies that are underway but whose findings are not yet published, etc.</i>
ADOT North- South Corridor Study ( <a href="http://www.azdot.gov/northsouthcorridorstudy/">http://www.azdot.gov/northsouthcorridorstudy/</a> ). ADOT US 60 Crimson Road to Meridian Road; FCDMC East Mesa ADMP ( <a href="http://www.fcd.maricopa.gov/Projects/PPM/projStructDetails.aspx?ProjectID=223">http://www.fcd.maricopa.gov/Projects/PPM/projStructDetails.aspx?ProjectID=223</a> ); ADOT Passenger Rail Corridor Study ( <a href="http://www.azdot.gov/passengerrail/">http://www.azdot.gov/passengerrail/</a> ) All these projects are on-going and their findings are not published yet.
<b>2.6 Development of alternatives</b>
<i>Were resource agencies, stakeholders, and members of the public engaged in the process of identifying, evaluating, and screening out modes, corridors, a range of alternatives,<sup>12</sup> or a preferred alternative (if one was identified—the latter two refer to corridor plans)? If so, how? Did these groups review the recommendation of a preferred mode(s), corridor(s), range of alternatives (including the no-build alternative), or an alternative? Were the participation and inputs of these groups at a level acceptable for use in purpose and need statements or alternatives development sections in NEPA documents? If not, why not?</i>
Identification and valuation of range of alternatives along with selection of preferred alternatives were carried out at TAC and stakeholder meetings. The public were engaged using flyers and an on-line questionnaire along with a public meeting.
<i>Describe the process of outreach to resource agencies, the public, and other stakeholders. Describe the documentation of this process and of the responses to their comments. Is this documentation adequate in breadth and detail for use in NEPA documents?</i>
Technical Advisory Committee, meetings with stakeholders, on-line questionnaire, and public meeting (refer to Public Involvement Summary Report for additional information). Letters sent to resources agencies.
<i>If the study was a corridor study, describe the range of alternatives considered (if any), screening process, and screening criteria. Include what types of alternatives were considered (including the no-build alternative) and how the screening criteria were selected. Was a preferred alternative selected as best addressing the identified transportation issue? Are alternatives' locations and design features specified?</i>
Concepts were developed for the northern section of the study area (McDowell to US 60) relating to lane configuration and right-of-way requirements. Conceptual alternatives for the southern section (US 60 to Germann Rd) were developed based on identified corridor issues, projected traffic volumes and transportation connectivity needs. (See Chapter IV of Working Paper #2). The screen criteria were developed based on both engineering and socioeconomic criteria. A matrix was developed to evaluate alternatives based on impacts to these criteria (See Chapter V of Working Paper #2). A 'No-build' alternative was included in the selection process.
<i>Also regarding whether the study was a corridor study, for alternatives that were screened out, summarize the reasons for their rejection. Are defensible, credible rationale articulated for their being screened out? Did the study team take into account legal standards<sup>13</sup> needed in the NEPA process for such decisions? Did the study team have adequate information for screening out the alternatives?</i>
Summary of screened out alternatives are described in Chapter V of Working Paper #2.
<i>What issues, if any, remain unresolved with the public, stakeholders, and/or resource agencies?</i>
US 60/Meridian Road Interchange design, cultural resources, biology and 404 permits will need to become better defined as the project moves into the design concept stage.
<b>2.7 Formally joining PEL with the NEPA process</b>
<i>Lead federal agencies proposing a project that will undergo the NEPA process will want to most effectively leverage the transportation planning study's efforts and results. How could a Notice of Intent (for an environmental impact statement<sup>14</sup>) refer to the study's findings with respect to preliminary purpose and need and/or the range of alternatives to be studied?</i>
The study's findings largely consolidated information and recommendations from other sources. Most of the projects identified are not anticipated to require an EIS based on the findings of this study.

<sup>12</sup> For an explanation of the development of alternatives in environmental documents, please see FHWA's "NEPA and Transportation Decisionmaking: Development and Evaluation of Alternatives," <[Alternatives](#)>.

<sup>13</sup> 23 Code of Federal Regulations (CFR) § 771.123(c), 23 CFR § 771.111(d), 40 CFR § 1502.14(a), 40 CFR § 1502.14(b) and (d), 23 CFR § 771.125(a)(1); see FHWA Technical Advisory T 6640.8A, October 30, 1987, <[FHWA Technical Advisory T 6640.8A](#)>.

<sup>14</sup> While Notices of Intent are required by some federal agencies for environmental assessments, they are optional for FHWA. Please see "3.3.2 Using the Notice of Intent to Link Planning and NEPA," in *Guidance on Using Corridor and Subarea Planning to Inform NEPA* (Federal Highway Administration, April 5, 2011), <[Notice of Intent](#)>.

<p><i>Could a Notice of Intent in the NEPA process clearly state that the lead federal agency or agencies will use analyses from prior, specific planning studies that are referenced in the transportation planning study final report? Does the report provide the name and source of the planning studies and explain where the studies are publicly available? If not, how could such relevant information come to the environmental planners' attention and be made available to them in a timely way?</i></p>		
<p>Yes, documents referenced are summarized in the Study.</p>		
<p><i>List how the study's proposed transportation system would support adopted land use plans and growth objectives.</i></p>		
<p>The recommendations that are included in the Study are a response to the needs identified in adopted land use and planning documents including MAG RTP, Apache Junction CTP and Pinal County RSRSM.</p>		
<p><i>What modifications are needed in the goals and objectives as defined in the transportation study process to increase their efficient and timely application in the NEPA process?</i></p>		
<p>No modification to the goals and objectives will be required.</p>		
<p><i>Jurisdictional delineations of waters of the United States frequently change. Housing and commercial developments can alter landscapes dramatically and can be constructed quickly. Noise and air quality regulations can change relatively rapidly. Resource agencies frequently alter habitat delineations to protect sensitive species. Will the study data's currency, relevance, and quality still be acceptable to agencies, stakeholders, and members of the public for use in the NEPA process? If not, what will be done to rectify this problem? Who will be responsible for any needed updating?</i></p>		
<p>When a project is ready to move forward to the Design Concept Report stage and ultimately the final design the environmental information from the study will need to be reevaluated and updated. The environmental data was based solely on existing data sources and a 'windshield survey' and not from extensive field work.</p>		
<p><b>2.8 Other issues</b></p>		
<p>Are there any other issues a future NEPA study team should be aware of (mark all that apply)? In the space below the check boxes, explain the nature and location of any issue(s) checked.</p> <table style="width: 100%; border: none;"> <tr> <td style="width: 50%; vertical-align: top;"> <input type="checkbox"/> Public and/or stakeholders have expressed specific concerns  <input checked="" type="checkbox"/> Utility problems  <input checked="" type="checkbox"/> Access or right-of-way issues  <input type="checkbox"/> Encroachments into right-of-way  <input checked="" type="checkbox"/> Need to engage—and be perceived as engaging—specific landowners, citizens, citizen groups, or other stakeholders             </td> <td style="width: 50%; vertical-align: top;"> <input type="checkbox"/> Contact information for stakeholders  <input type="checkbox"/> Special or unique resources in the area  <input type="checkbox"/> Federal regulations that are undergoing initial promulgation or revision  <input type="checkbox"/> Other _____             </td> </tr> </table>	<input type="checkbox"/> Public and/or stakeholders have expressed specific concerns <input checked="" type="checkbox"/> Utility problems <input checked="" type="checkbox"/> Access or right-of-way issues <input type="checkbox"/> Encroachments into right-of-way <input checked="" type="checkbox"/> Need to engage—and be perceived as engaging—specific landowners, citizens, citizen groups, or other stakeholders	<input type="checkbox"/> Contact information for stakeholders <input type="checkbox"/> Special or unique resources in the area <input type="checkbox"/> Federal regulations that are undergoing initial promulgation or revision <input type="checkbox"/> Other _____
<input type="checkbox"/> Public and/or stakeholders have expressed specific concerns <input checked="" type="checkbox"/> Utility problems <input checked="" type="checkbox"/> Access or right-of-way issues <input type="checkbox"/> Encroachments into right-of-way <input checked="" type="checkbox"/> Need to engage—and be perceived as engaging—specific landowners, citizens, citizen groups, or other stakeholders	<input type="checkbox"/> Contact information for stakeholders <input type="checkbox"/> Special or unique resources in the area <input type="checkbox"/> Federal regulations that are undergoing initial promulgation or revision <input type="checkbox"/> Other _____	
<p>Utility Problems – O/H power lines along Meridian Road north of Baseline Road, crossing of Powerline Floodway, existing FCDMC drainage channel along Meridian Rd alignment.                  Right of way – Further investigation required to verify existing right of way between McDowell Blvd and Baseline Road. No Right of way has been preserved on State Trust Land south of Baseline Road.</p>		

**2.9 Concurrence**

By signature, we concur that the transportation planning document meets or exceeds the following criteria in terms of acceptability for application in NEPA projects:

- Public involvement (outreach and level of participation)
- Stakeholder involvement (outreach and level of participation)
- Resource agencies' involvement and participation
- Documentation of the above efforts
- Applicability of the general findings and conclusions for use, by reference, in NEPA documents

Approved by:  Date: 08/13/2013  
JENNIFER TOTH

State Engineer  
Arizona Department of Transportation

Approved by:  Date: 8/17/13  
SCOTT OMER

Director  
Multimodal Planning Division, Arizona Department of Transportation

Approved by:  Date: 10/9/13  
KARLA PETTY

Division Administrator  
Federal Highway Administration

### Checklist for Environmental Planners – Part 3

By completing this checklist, environmental planners will be able to systematically evaluate the transportation planning study with regard to environmental resources and issues. It provides a framework for future NEPA studies by identifying those resources and issues that have already been evaluated, and those that have not. The role of environmental planners during the study’s various stages is laid out in the flowchart on page 3. This role includes timely advocacy for resources and issues that will later be integral to NEPA processes.

3.1 Checklist for environmental planners				
Resource or issue	Is the resource or issue present in the area?	Are impacts to the resource or issue involvement possible?	Are the impacts mitigable?	Discuss the level of review and method of review for this resource or issue and provide the name and location of any study or other information cited in the planning document where it is described in detail. Describe how the planning data may need to be supplemented during NEPA.
<i>Natural environment</i>				
Sensitive biological resources	<input type="checkbox"/> Yes <input type="checkbox"/> No <input checked="" type="checkbox"/> Unknown <input type="checkbox"/> Not applicable	<input type="checkbox"/> Yes <input type="checkbox"/> No <input checked="" type="checkbox"/> Unknown <input type="checkbox"/> Not applicable	<input type="checkbox"/> Yes <input type="checkbox"/> No <input checked="" type="checkbox"/> Unknown <input type="checkbox"/> Not applicable	A review of biological databases was performed for this study, but a biologist did not visit the study area. At a minimum, a biological review should be performed as part of the NEPA study during project development.
Wildlife corridors	<input checked="" type="checkbox"/> Yes <input type="checkbox"/> No <input type="checkbox"/> Unknown <input type="checkbox"/> Not applicable	<input checked="" type="checkbox"/> Yes <input type="checkbox"/> No <input type="checkbox"/> Unknown <input type="checkbox"/> Not applicable	<input type="checkbox"/> Yes <input type="checkbox"/> No <input checked="" type="checkbox"/> Unknown <input type="checkbox"/> Not applicable	AGFD department Wildlife Linkages assessments indicated that a portion of the study area north of US 60 is in a Wildlife Movement area. However, much of this area is developed on both sides of Meridian Rd. Coordination with ADGF is recommended to determine if any practicable linkage opportunities exist for this project.
Invasive species	<input type="checkbox"/> Yes <input type="checkbox"/> No <input checked="" type="checkbox"/> Unknown <input type="checkbox"/> Not applicable	<input type="checkbox"/> Yes <input type="checkbox"/> No <input checked="" type="checkbox"/> Unknown <input type="checkbox"/> Not applicable	<input checked="" type="checkbox"/> Yes <input type="checkbox"/> No <input type="checkbox"/> Unknown <input type="checkbox"/> Not applicable	Invasive species mitigation measures should be included in the NEPA clearance.
Wetland areas	<input type="checkbox"/> Yes <input type="checkbox"/> No <input checked="" type="checkbox"/> Unknown <input type="checkbox"/> Not applicable	<input type="checkbox"/> Yes <input type="checkbox"/> No <input checked="" type="checkbox"/> Unknown <input type="checkbox"/> Not applicable	<input type="checkbox"/> Yes <input type="checkbox"/> No <input checked="" type="checkbox"/> Unknown <input type="checkbox"/> Not applicable	A biologist or water quality specialist did not visit the study area; however, some washes cross Meridian Road. These areas should be surveyed for the presence of wetlands as part of the NEPA study.
Riparian areas	<input type="checkbox"/> Yes <input type="checkbox"/> No <input checked="" type="checkbox"/> Unknown <input type="checkbox"/> Not applicable	<input type="checkbox"/> Yes <input type="checkbox"/> No <input checked="" type="checkbox"/> Unknown <input type="checkbox"/> Not applicable	<input type="checkbox"/> Yes <input type="checkbox"/> No <input checked="" type="checkbox"/> Unknown <input type="checkbox"/> Not applicable	The study area should be surveyed for riparian areas as part of the NEPA study.
100-year floodplain	<input checked="" type="checkbox"/> Yes <input type="checkbox"/> No <input type="checkbox"/> Unknown <input type="checkbox"/> Not applicable	<input checked="" type="checkbox"/> Yes <input type="checkbox"/> No <input type="checkbox"/> Unknown <input type="checkbox"/> Not applicable	<input checked="" type="checkbox"/> Yes <input type="checkbox"/> No <input type="checkbox"/> Unknown <input type="checkbox"/> Not applicable	Floodplain impacts should be re-evaluated during project development.
Clean Water Act Sections 404/401 waters of the United States	<input checked="" type="checkbox"/> Yes <input type="checkbox"/> No <input type="checkbox"/> Unknown <input type="checkbox"/> Not applicable	<input checked="" type="checkbox"/> Yes <input type="checkbox"/> No <input type="checkbox"/> Unknown <input type="checkbox"/> Not applicable	<input type="checkbox"/> Yes <input type="checkbox"/> No <input checked="" type="checkbox"/> Unknown <input type="checkbox"/> Not applicable	Since washes cross Meridian Road, a 404 review will need to be performed during the NEPA study.
Prime or unique farmland	<input type="checkbox"/> Yes <input type="checkbox"/> No <input checked="" type="checkbox"/> Unknown <input type="checkbox"/> Not applicable	<input type="checkbox"/> Yes <input type="checkbox"/> No <input checked="" type="checkbox"/> Unknown <input type="checkbox"/> Not applicable	<input type="checkbox"/> Yes <input type="checkbox"/> No <input checked="" type="checkbox"/> Unknown <input type="checkbox"/> Not applicable	There is some farmland at the southern end of the study area. Farmland should be evaluated during the NEPA study.
Farmland of statewide or local importance	<input type="checkbox"/> Yes <input type="checkbox"/> No <input checked="" type="checkbox"/> Unknown <input type="checkbox"/> Not applicable	<input type="checkbox"/> Yes <input type="checkbox"/> No <input checked="" type="checkbox"/> Unknown <input type="checkbox"/> Not applicable	<input type="checkbox"/> Yes <input type="checkbox"/> No <input checked="" type="checkbox"/> Unknown <input type="checkbox"/> Not applicable	Same as above.

3.1 Checklist for environmental planners				
Resource or issue	Is the resource or issue present in the area?	Are impacts to the resource or issue involvement possible?	Are the impacts mitigable?	Discuss the level of review and method of review for this resource or issue and provide the name and location of any study or other information cited in the planning document where it is described in detail. Describe how the planning data may need to be supplemented during NEPA.
Sole-source aquifers	<input type="checkbox"/> Yes <input type="checkbox"/> No <input checked="" type="checkbox"/> Unknown <input type="checkbox"/> Not applicable	<input type="checkbox"/> Yes <input type="checkbox"/> No <input checked="" type="checkbox"/> Unknown <input type="checkbox"/> Not applicable	<input type="checkbox"/> Yes <input type="checkbox"/> No <input checked="" type="checkbox"/> Unknown <input type="checkbox"/> Not applicable	Sole-source aquifers should be evaluated during the NEPA study.
Wild and scenic rivers	<input type="checkbox"/> Yes <input checked="" type="checkbox"/> No <input type="checkbox"/> Unknown <input type="checkbox"/> Not applicable	<input type="checkbox"/> Yes <input checked="" type="checkbox"/> No <input type="checkbox"/> Unknown <input type="checkbox"/> Not applicable	<input type="checkbox"/> Yes <input type="checkbox"/> No <input type="checkbox"/> Unknown <input checked="" type="checkbox"/> Not applicable	N/A
Visual resources	<input type="checkbox"/> Yes <input type="checkbox"/> No <input checked="" type="checkbox"/> Unknown <input type="checkbox"/> Not applicable	<input type="checkbox"/> Yes <input type="checkbox"/> No <input checked="" type="checkbox"/> Unknown <input type="checkbox"/> Not applicable	<input type="checkbox"/> Yes <input type="checkbox"/> No <input checked="" type="checkbox"/> Unknown <input type="checkbox"/> Not applicable	Visual resources should be evaluated during the NEPA study.
Designated scenic road/byway	<input type="checkbox"/> Yes <input checked="" type="checkbox"/> No <input type="checkbox"/> Unknown <input type="checkbox"/> Not applicable	<input type="checkbox"/> Yes <input checked="" type="checkbox"/> No <input type="checkbox"/> Unknown <input type="checkbox"/> Not applicable	<input type="checkbox"/> Yes <input type="checkbox"/> No <input type="checkbox"/> Unknown <input checked="" type="checkbox"/> Not applicable	N/A
<b>Cultural resources</b>				
Archaeological resources	<input checked="" type="checkbox"/> Yes <input type="checkbox"/> No <input type="checkbox"/> Unknown <input type="checkbox"/> Not applicable	<input type="checkbox"/> Yes <input type="checkbox"/> No <input checked="" type="checkbox"/> Unknown <input type="checkbox"/> Not applicable	<input type="checkbox"/> Yes <input type="checkbox"/> No <input checked="" type="checkbox"/> Unknown <input type="checkbox"/> Not applicable	A records review revealed several archaeological sites in the study area. A cultural resources survey should be performed as part of the NEPA study.
Historical resources	<input type="checkbox"/> Yes <input type="checkbox"/> No <input checked="" type="checkbox"/> Unknown <input type="checkbox"/> Not applicable	<input type="checkbox"/> Yes <input type="checkbox"/> No <input checked="" type="checkbox"/> Unknown <input type="checkbox"/> Not applicable	<input type="checkbox"/> Yes <input type="checkbox"/> No <input checked="" type="checkbox"/> Unknown <input type="checkbox"/> Not applicable	Historical resources should be evaluated as part of the cultural resources study during NEPA. Recognize that cultural resources may be subject to protection under section 4(f) of the USDOT Act and thus could result in changes to the preferred alternative during project development.
<b>Section 4(f) and Section 6(f) resources</b>				
Section 4(f) wildlife and/or waterfowl refuge	<input type="checkbox"/> Yes <input checked="" type="checkbox"/> No <input type="checkbox"/> Unknown <input type="checkbox"/> Not applicable	<input type="checkbox"/> Yes <input type="checkbox"/> No <input checked="" type="checkbox"/> Unknown <input type="checkbox"/> Not applicable	<input type="checkbox"/> Yes <input type="checkbox"/> No <input checked="" type="checkbox"/> Unknown <input type="checkbox"/> Not applicable	None have been identified at this time; however, this should be re-evaluated during NEPA.
Section 4(f) historic site	<input checked="" type="checkbox"/> Yes <input type="checkbox"/> No <input type="checkbox"/> Unknown <input type="checkbox"/> Not applicable	<input type="checkbox"/> Yes <input type="checkbox"/> No <input checked="" type="checkbox"/> Unknown <input type="checkbox"/> Not applicable	<input type="checkbox"/> Yes <input type="checkbox"/> No <input checked="" type="checkbox"/> Unknown <input type="checkbox"/> Not applicable	Historical resources should be evaluated as part of cultural resources study during NEPA.
Section 4(f) recreational site	<input checked="" type="checkbox"/> Yes <input type="checkbox"/> No <input type="checkbox"/> Unknown <input type="checkbox"/> Not applicable	<input type="checkbox"/> Yes <input type="checkbox"/> No <input checked="" type="checkbox"/> Unknown <input type="checkbox"/> Not applicable	<input type="checkbox"/> Yes <input type="checkbox"/> No <input checked="" type="checkbox"/> Unknown <input type="checkbox"/> Not applicable	Recreational sites are located in the project vicinity; however, none are directly impacted by the preferred alternative. This will need to be re-evaluated during project development.
Section 4(f) park	<input checked="" type="checkbox"/> Yes <input type="checkbox"/> No <input type="checkbox"/> Unknown <input type="checkbox"/> Not applicable	<input type="checkbox"/> Yes <input type="checkbox"/> No <input checked="" type="checkbox"/> Unknown <input type="checkbox"/> Not applicable	<input type="checkbox"/> Yes <input type="checkbox"/> No <input checked="" type="checkbox"/> Unknown <input type="checkbox"/> Not applicable	Parks are located in the project vicinity; however, none are directly impacted by the preferred alternative. This will need to be re-evaluated during project development.
Section 6(f) resource	<input type="checkbox"/> Yes <input type="checkbox"/> No <input checked="" type="checkbox"/> Unknown <input type="checkbox"/> Not applicable	<input type="checkbox"/> Yes <input type="checkbox"/> No <input checked="" type="checkbox"/> Unknown <input type="checkbox"/> Not applicable	<input type="checkbox"/> Yes <input type="checkbox"/> No <input checked="" type="checkbox"/> Unknown <input type="checkbox"/> Not applicable	Section 6(f) resources will need to be evaluated during project development.
<b>Human environment</b>				
Existing development	<input checked="" type="checkbox"/> Yes <input type="checkbox"/> No <input type="checkbox"/> Unknown <input type="checkbox"/> Not applicable	<input checked="" type="checkbox"/> Yes <input type="checkbox"/> No <input type="checkbox"/> Unknown <input type="checkbox"/> Not applicable	<input type="checkbox"/> Yes <input type="checkbox"/> No <input checked="" type="checkbox"/> Unknown <input type="checkbox"/> Not applicable	Existing development is present in the vicinity of Meridian Road and may be impacted by this project. The extent and nature of any impacts that may occur will be determined during project development.



3.1 Checklist for environmental planners				
Resource or issue	Is the resource or issue present in the area?	Are impacts to the resource or issue involvement possible?	Are the impacts mitigable?	Discuss the level of review and method of review for this resource or issue and provide the name and location of any study or other information cited in the planning document where it is described in detail. Describe how the planning data may need to be supplemented during NEPA.
Planned development	<input checked="" type="checkbox"/> Yes <input type="checkbox"/> No <input type="checkbox"/> Unknown <input type="checkbox"/> Not applicable	<input type="checkbox"/> Yes <input type="checkbox"/> No <input checked="" type="checkbox"/> Unknown <input type="checkbox"/> Not applicable	<input type="checkbox"/> Yes <input type="checkbox"/> No <input checked="" type="checkbox"/> Unknown <input type="checkbox"/> Not applicable	Development is planned in the project vicinity. The identification of a reasonable range of alternatives and a preferred alternative could help inform the direction of that development.
Displacements	<input type="checkbox"/> Yes <input type="checkbox"/> No <input checked="" type="checkbox"/> Unknown <input type="checkbox"/> Not applicable	<input type="checkbox"/> Yes <input type="checkbox"/> No <input checked="" type="checkbox"/> Unknown <input type="checkbox"/> Not applicable	<input type="checkbox"/> Yes <input type="checkbox"/> No <input checked="" type="checkbox"/> Unknown <input type="checkbox"/> Not applicable	Evaluate during project development.
Access restriction	<input checked="" type="checkbox"/> Yes <input type="checkbox"/> No <input type="checkbox"/> Unknown <input type="checkbox"/> Not applicable	<input checked="" type="checkbox"/> Yes <input type="checkbox"/> No <input type="checkbox"/> Unknown <input type="checkbox"/> Not applicable	<input checked="" type="checkbox"/> Yes <input type="checkbox"/> No <input type="checkbox"/> Unknown <input type="checkbox"/> Not applicable	This project has access control measures.
Neighborhood continuity	<input checked="" type="checkbox"/> Yes <input type="checkbox"/> No <input type="checkbox"/> Unknown <input type="checkbox"/> Not applicable	<input checked="" type="checkbox"/> Yes <input type="checkbox"/> No <input type="checkbox"/> Unknown <input type="checkbox"/> Not applicable	<input type="checkbox"/> Yes <input type="checkbox"/> No <input checked="" type="checkbox"/> Unknown <input type="checkbox"/> Not applicable	Neighborhood continuity is considered in the development of proposed solutions in this planning study.
Community cohesion	<input checked="" type="checkbox"/> Yes <input type="checkbox"/> No <input type="checkbox"/> Unknown <input type="checkbox"/> Not applicable	<input checked="" type="checkbox"/> Yes <input type="checkbox"/> No <input type="checkbox"/> Unknown <input type="checkbox"/> Not applicable	<input type="checkbox"/> Yes <input type="checkbox"/> No <input checked="" type="checkbox"/> Unknown <input type="checkbox"/> Not applicable	Community cohesion is considered in the development of proposed solutions in this planning study.
Title VI/Environmental justice populations	<input checked="" type="checkbox"/> Yes <input type="checkbox"/> No <input type="checkbox"/> Unknown <input type="checkbox"/> Not applicable	<input type="checkbox"/> Yes <input type="checkbox"/> No <input checked="" type="checkbox"/> Unknown <input type="checkbox"/> Not applicable	<input type="checkbox"/> Yes <input type="checkbox"/> No <input checked="" type="checkbox"/> Unknown <input type="checkbox"/> Not applicable	At this time Title VI populations are fairly low in the project study area. This should be re-evaluated during project development.
<b>Physical environment</b>				
Utilities	<input checked="" type="checkbox"/> Yes <input type="checkbox"/> No <input type="checkbox"/> Unknown <input type="checkbox"/> Not applicable	<input checked="" type="checkbox"/> Yes <input type="checkbox"/> No <input type="checkbox"/> Unknown <input type="checkbox"/> Not applicable	<input checked="" type="checkbox"/> Yes <input type="checkbox"/> No <input type="checkbox"/> Unknown <input type="checkbox"/> Not applicable	Utilities will be addressed during project development.
Hazardous materials	<input checked="" type="checkbox"/> Yes <input type="checkbox"/> No <input type="checkbox"/> Unknown <input type="checkbox"/> Not applicable	<input type="checkbox"/> Yes <input type="checkbox"/> No <input checked="" type="checkbox"/> Unknown <input type="checkbox"/> Not applicable	<input type="checkbox"/> Yes <input type="checkbox"/> No <input checked="" type="checkbox"/> Unknown <input type="checkbox"/> Not applicable	Some hazardous materials generators are present in the project study area. A hazardous materials evaluation should be performed during project development.
Sensitive noise receivers	<input checked="" type="checkbox"/> Yes <input type="checkbox"/> No <input type="checkbox"/> Unknown <input type="checkbox"/> Not applicable	<input checked="" type="checkbox"/> Yes <input type="checkbox"/> No <input type="checkbox"/> Unknown <input type="checkbox"/> Not applicable	<input type="checkbox"/> Yes <input type="checkbox"/> No <input checked="" type="checkbox"/> Unknown <input type="checkbox"/> Not applicable	A noise evaluation should be performed during project development.
Air quality	<input checked="" type="checkbox"/> Yes <input type="checkbox"/> No <input type="checkbox"/> Unknown <input type="checkbox"/> Not applicable	<input checked="" type="checkbox"/> Yes <input type="checkbox"/> No <input type="checkbox"/> Unknown <input type="checkbox"/> Not applicable	<input type="checkbox"/> Yes <input type="checkbox"/> No <input checked="" type="checkbox"/> Unknown <input type="checkbox"/> Not applicable	The project is located in a non-attainment area. An air quality evaluation should be performed during project development.
Other (list)	<input type="checkbox"/> Yes <input type="checkbox"/> No <input type="checkbox"/> Unknown <input type="checkbox"/> Not applicable	<input type="checkbox"/> Yes <input type="checkbox"/> No <input type="checkbox"/> Unknown <input type="checkbox"/> Not applicable	<input type="checkbox"/> Yes <input type="checkbox"/> No <input type="checkbox"/> Unknown <input type="checkbox"/> Not applicable	

3.2 Identification of potential environmental mitigation activities
<p><i>Could the transportation planning process be integrated with other planning activities, such as land use or resource management plans? If so, could this integrated planning effort be used to develop a more strategic approach to environmental mitigation measures?</i></p> <p>This study could be used to inform city and county planning efforts. Coordination with AGFD could help determine if there are any wildlife linkage opportunities in the study area.</p>

<i>With respect to potential environmental mitigation opportunities at the PEL level, who should ADOT consult with among federal, State, and local agencies and tribes and how formally and frequently should such consultation be undertaken?</i>
Coordination with AGFD could help determine if there are any wildlife linkage opportunities in the study area.
<b>3.2 Identification of potential environmental mitigation activities</b>
<i>Off-site and compensatory mitigation areas are often creatively negotiated to advance multiagency objectives or multiple objectives within one agency. Who determined what specific geographic areas or types of areas were appropriate for environmental mitigation activities? How were these determinations made?</i>
No off-site or compensatory mitigations were identified in this study.
<i>To address potential impacts on the human environment, what mitigation measures or activities were considered and how were they developed and documented?</i>
This project is expected to have a positive impact to the human environment in the area. Negative impacts are expected to be small and localized and mitigations for these impacts will be addressed during project development.

Prepared by: Thor Anderson

Date: 5-10-13

Environmental Planning Group, Arizona Department of Transportation

## Technical Advisory Committee Members

Charla Glendening  
Project Manager  
Arizona Department of Transport  
Multimodal Planning Division  
206 S. 17<sup>th</sup> Avenue, Mail Drop 301B  
Phoenix, AZ 85007  
[cglendening@azdot.gov](mailto:cglendening@azdot.gov)

Mark Griffin  
Transportation Planning Director  
CAG  
1075 S. Idaho Road, Suite 300  
Apache Junction, AZ 85119  
[mgriffin@caagcentral.org](mailto:mgriffin@caagcentral.org)

Tim Oliver  
Planning Manager  
Maricopa County Department of Transport  
2901 W. Durango Street  
Phoenix, AZ 85009  
[timoliver@mail.maricopa.gov](mailto:timoliver@mail.maricopa.gov)

Andy Smith  
Senior Transportation Planner  
Public Works Department  
31 N. Pinal Street, Building F  
P.O. Box 727  
Florence, AZ 85132  
[Andrew.smith@pinalcountyaz.gov](mailto:Andrew.smith@pinalcountyaz.gov)

Cathy Regester  
Flood Control District of Maricopa County  
2801 W. Durango Street  
Phoenix, AZ 85009  
[cregester@mail.maricopa.gov](mailto:cregester@mail.maricopa.gov)

Tim Wolf  
Assistant State Engineer  
Arizona Department of Transport  
206 S. 17<sup>th</sup> Avenue  
Phoenix, AZ 85007  
[twolf@azdot.gov](mailto:twolf@azdot.gov)

Wayne Balmer  
Planning Administrator  
Town of Queen Creek  
22350 S. Ellsworth Road  
Queen Creek, AZ 85142  
[Wayne.balmer@queencreek.org](mailto:Wayne.balmer@queencreek.org)

Lars Jacoby  
Community Relation Project Manager  
Arizona Department of Transport  
206 S. 17<sup>th</sup> Avenue  
Phoenix, AZ 85007  
[ljacoby@azdot.gov](mailto:ljacoby@azdot.gov)

Mike Sabatini  
Baker Project Manager  
Michael Baker Jr., Inc.  
2929 N. Central Avenue  
Phoenix, AZ 85012  
[michael.sabatini@mbakercorp.com](mailto:michael.sabatini@mbakercorp.com)

Giao Pham  
Public Works Director  
City of Apache Junction  
575 E. Baseline Avenues  
Apache Junction, AZ 85219  
[gpham@ajcity.net](mailto:gpham@ajcity.net)

Doug Hansen  
Planning Section Chief  
Public Works Department  
Pinal County  
31 N. Pinal Street, Building F  
P.O. Box 727, Florence, AZ 85132  
[Doug.Hansen@pinalcountyaz.gov](mailto:Doug.Hansen@pinalcountyaz.gov)

Ken Hall  
Senior Planner  
Mesa Transportation Department  
300 E. Sixth Street  
P.O. Box 1466  
Mesa, AZ 85211  
[Kenneth.hall@mesaz.gov](mailto:Kenneth.hall@mesaz.gov)

Ralph Ellis  
Environmental Planner  
Arizona Department of Transport  
Environmental Planning Group  
1611 W. 21<sup>st</sup> Street  
Phoenix, AZ 85007  
[rellis@azdot.gov](mailto:rellis@azdot.gov)

Jen Pokorski  
Flood Control District of Maricopa County  
2801 W. Durango Street  
Phoenix, AZ 85009  
[jpokorski@mail.maricopa.gov](mailto:jpokorski@mail.maricopa.gov)

Michelle Green  
Arizona State Lands Department  
1616 W. Adams Street  
Phoenix, AZ 85007  
[mgreen@land.az.gov](mailto:mgreen@land.az.gov)

Audra Koester Thomas  
Partners for Strategic Action  
13771 N. Fountain Hills Blvd,  
Suite 114-360  
Fountain Hills, AZ 85268  
[audra@psaplanning.com](mailto:audra@psaplanning.com)

Ed Stillings  
Senior Transportation Planner  
FHWA Arizona Division  
4000 N. Central Avenue, Suite 1500  
Phoenix, AZ 85012  
[ed.stillings@dot.gov](mailto:ed.stillings@dot.gov)

Simon Pratt  
Baker Project Engineer  
Michael Baker Jr., Inc.  
2929 N. Central Avenue  
Phoenix, AZ 85012  
[spratt@mbakercorp.com](mailto:spratt@mbakercorp.com)

## Summary of Previous Studies

Doc. Type	Jurisdiction Agency	Author/Originator	Document Title	Date
Report	Arizona Department of Transportation, City of Apache Junction	Jacobs	Apache Junction Transit Feasibility Study Update	Jun-12
Report	Arizona Department of Transportation, City of Apache Junction	Jacobs	Apache Junction Comprehensive Transportation Study	May-12
Report	Arizona Department of Transportation	HDR Engineering, Inc.	North-South Corridor Study Draft Purpose and Need	Dec-11
Report	Arizona Department of Transportation	N/A	Germann Road Corridor Improvement Study Power Road to Ironwood Road A Planning Assistance for Rural Areas Study Phase I Public Involvement Report	Dec-11
PARA Study Application	Arizona Department of Transportation	Pinal County	Meridian Road Corridor Study	Aug-11
Report	Arizona Department of Transportation	N/A	State Route 802, Williams Gateway Freeway Final Environmental Assessment and Appendices	Apr-11
Report	Arizona State Land Department	Robert Grow	Superstition Vistas: Final Report and Strategic Actions	Spring 2011
Exhibit	Arizona State Land Department	N/A	Pinal County (Superstition Vistas) Proposed Comprehensive Plan Amendment	May-11
Report	Arizona State Land Department	Jackie Guthrie & Associates	Superstition Vistas: Pinal County Comprehensive Plan Amendment	Jun-11
Memorandum	Arizona State Land Department	Robert Charles Lesser & Company, Inc.	Underlying Assumptions and Argument in Support of Household and Employment Growth Projections for Superstition Vistas Arizona State Trust Land	May-09
Report	Arizona State Land Department	Robert Grow Consulting	Superstition Vistas: Environmental Armature Concept Summary	Apr-09
White Paper	N/A	EDAW Inc.	Superstition Vistas Water Strategy White Paper	Apr-09
White Paper	N/A	Kimley-Horn and Associates, Inc.	Superstition Vistas Transportation Planning White Paper	N/A
White Paper	N/A	Fregonese Associates	Superstition Vistas White Paper: Land Use Scenario Development	Mar-09
Report	City of Mesa	HDR Engineering, Inc.	Mesa Gateway Strategic Development Plan: Transportation Analysis Memorandum	Jan-09
Report	City of Mesa	N/A	City of Mesa Transportation Plan	Jun-02
Plans	Flood Control District of Maricopa County; City of Mesa	Stanley Consultants,	Siphon Draw Improvements Phase 2	Apr-09
Plans	Flood Control District of Maricopa County; City of Mesa	Stanley Consultants,	Siphon Draw Improvements Phase 1	Jan-09
Plans	Maricopa County Department of Transportation	YSMA Transportation Engineering Solutions	Intersection Improvements of Southern Avenue and Meridian Road	Jul-11
Book of Summaries	Maricopa County Department of Transportation	N/A	2010 Maricopa County Department of Transportation Corridor Studies Book of Summaries	Jan-11
Report	Maricopa County Department of Transportation	EPS Group, Inc.	Signal Butte Corridor Improvement Study: US 60 to Rittenhouse Road	Dec-09
Memorandum of Understanding	Maricopa County Department of Transportation, City of Mesa	N/A	Memorandum of Understanding Between Maricopa County and the City of Mesa for Plan Review, Plan Approval, Permitting, Inspection, Construction, Annexation, Operation and Maintenance of Elliot Road from Power Road to Meridian Road	Aug-08
Report	Maricopa County Department of Transportation	Kimley-Horn and Associates, Inc.	Elliot Road Corridor Improvement Study: Power Road to the Central Arizona Project Canal	Jun-08
Report	Maricopa County Department of Transportation	URS	Meridian Road Access Control and Corridor Improvement Study	Jan-06
Report	Pinal County	Nygaard/Nelson Consulting Associates	Pinal County Transit Feasibility Study Final Report	Apr-11
Report	Pinal County	Lima & Associates	Regionally Significant Routes for Safety and Mobility	Dec-08
Report	Pinal County	Kirkham Michael Consulting Engineers	Pinal County Small Area Transportation Study Final Report	Aug-06
Report	Pinal County	Kirkham Michael Consulting Engineers	Pinal County Small Area Transportation Study Final Transit Element Report	Aug-06
Report	Town of Queen Creek	Cambridge Systematics, Inc.	Queen Creek Small Area Transportation Study	May-07