



VOLUME I

CONSTRUCTION COST MANUAL

State of Arizona

Copyright 2009 by Marshall and Swift.
All Rights Reserved.

Marshall & Swift/Boeckh retains all proprietary, copyright and other rights to the cost data shown.
Selected graphics reprinted from the Marshall Valuation Service (copyright 2009) and the Residential Cost Handbook (copyright 2009), by permission of the publisher Marshall & Swift.

STATE OF ARIZONA

Department of Revenue
Property Tax Division
(602) 716-6843
Fax (602) 542-4425



Janice K. Brewer
Governor

Gale Garriott
Director

MEMORANDUM

Date: October 1, 2009

TO: All Construction Cost Manual Holders

FROM: Rick Orzepowski
Supervisor, Construction Cost Team

SUBJECT: Reissue of the Construction Cost Manual
Effective October, 2009

Enclosed is the annual reissue of the Construction Cost Manual. In order to make the document more user-friendly, there have been significant software enhancements since the last reissue. The Authorware version of the Manual was removed from the CD because comparable software features have been incorporated into the printable Adobe version.

For Example, the [blue font](#) in the Manual indicates a hyperlink. Rolling the curser over the hyperlink will cause the curser to change. Left clicking the mouse while the curser is over the hyperlink will take the reader to more information about that topic. Clicking the *previous view* button located to the right of the page navigation arrows will return the reader to their previous page.

Double-clicking the blue pin icon  will take the reader to printable copies of the listed forms. Closing the printable forms screen will return the reader to the original page.

Revisions by page number since the last reissue include:

Volume 1, Section 3:

Page 94. Addition of components RWY, Runway, Airport and RWYR, Runway Replacement, Airport
Page 101. Addition of the Tax Year 2011 Statutory Golf Course per Hole Costs

Volume 1, Section 4:

Page 108. Tax Year 2011 Location Multipliers
Page 111. Tax Year 2011 Residential Depreciation Schedule
Page 112. Tax Year 2011 Factory List Price Mobile Home Depreciation Schedule
Page 114. Tax Year 2011 Statutory Shopping Center Depreciation / Obsolescence Schedule

Volume 2, Components:

Page 1000. Addition of components RWY, Runway, Airport and RWYR, Runway Replacement, Airport

Printable Forms:

Updated forms. 82369-SF, Mobile Home Square Foot Data Collection Form

TABLE OF CONTENTS**VOLUME I**

INTRODUCTION	Section 1
FORMS AND INSTRUCTIONS	Section 2
COMPONENT LIST	Section 3
ADJUSTMENTS	Section 4
MODELS	Section 5
RESIDENTIAL	Section 6
COMMERCIAL	Section 7
AGRICULTURAL	Section 8
LISTING TECHNIQUES	Appendix A

VOLUME II

COMPONENT DESCRIPTIONS	A through Y
GLOSSARY	Appendix A
MISCELLANEOUS	Appendix B

ARIZONA DEPARTMENT OF REVENUE
CONSTRUCTION COST MANUAL

SECTION 1
INTRODUCTION

ARIZONA DEPARTMENT OF REVENUE CONSTRUCTION COST SYSTEM

The Arizona Department of Revenue Construction Cost System (CCS) is a version of the Marshall & Swift Segregated Cost System. For a description of the Square Foot Method enhancement, see Appendix A- Listing Techniques. All of the cost information with few exceptions, e.g., feedlots and mobile homes permanently affixed, is provided by Marshall & Swift. The data processing support system is provided by the Arizona Department of Revenue.

The cost system is designed to be a flexible system that will allow the county assessors throughout the state to accurately estimate the Replacement Cost New (RCN) of any structure. As with any cost system, including the CCS or other approaches to value, the primary objective is to develop values compatible with market sales data. The values generated by the system must be measured against a market standard and, if necessary, adjustments made to the final values to ensure market compatibility.

The segregated cost method separates the construction of a building into elements or related groups such as floors, walls, roofs, electrical, and plumbing, then prices these as components or units. The sum of these and any other pertinent components would then equal the RCN of the building.

The RCN of any improvement is calculated by listing the major characteristics of the improvement on the baseline. These items are the model number (including the quality indicator), grade, construction class (A, B, C, D, S), perimeter, square footage, number of stories, story height, and the age of the structure. Once these items are entered, the process is completed by listing the components in the building, e.g., type of exterior wall, roof structure and cover. The quality ranking of each component listed will follow the quality indicator and grade of the building. An option to change the individual components may be exercised as variations occur in the construction. This option is available for all components.

The costs generated by the CCS are driven by the baseline factors listed. Any variation among these items may cause the component costs to be different from one building to another. Therefore, the same component list on two similar buildings may have completely different values. This may be caused by different original-use designs, quality grades, construction types, and other important factors.

For each component in the Marshall & Swift system, there can be from one to 600 different costs in the database. The number depends on whether Marshall & Swift's research on construction costs (material, labor, profit, and overhead) finds that a component cost is the same for all models or varies with model type (office building, residence, etc.) or construction class (block, frame, or steel). These costs, or raw costs as they are called, are further adjusted to make them more accurate for the specific improvement being appraised.

There are four adjustments that can affect component costs. These are:

1. **Foundation.** The foundation components are adjusted for type of structure, the construction class indicator, and the number of stories. Different wall types (block vs. frame) or multiple stories require different size foundations.
2. **Number of Stories.** Marshall & Swift's models are developed with a base number of stories. For example, if the base number of stories is 3, then a 1- or 2-story building will have a factor of less than 1.00. Conversely, a building of 4 or more stories will have a factor of more than 1.00 reflecting the added costs (cranes, construction elevators, man-hours to move material, etc.) required for high-rise construction. Each component of the building will be adjusted by this factor.

-
3. **Wall or Story Height.** Some components such as interior construction, heating and cooling will be adjusted to accurately reflect the interior space of the building. There is a direct relationship between the height of the ceiling and the height of the partition walls and the capacity of the heating and cooling system. This adjustment takes into account the type of model, the construction class, and the story height.
 4. **Architect Fee.** Each component cost is adjusted for the architect fee that varies depending on the type of structure, construction class, and the construction grade of the structure. The higher-grade buildings will require more design time and a higher architect fee than one of average grade.

Once the building has been listed, the CCS will generate a cost estimate of the RCN for the entire building and apply a depreciation factor against the RCN to generate a value for the building. Additional depreciation or modernization may be applied if necessary. These factors should allow the appraiser to adjust for such items as unusual deterioration or remodeling to the building, as well as address poor design or conditions outside the property that cause a decrease in the value of the building.

The last step in the cost approach to value is to add the value of the building site. The land value is usually determined by reviewing the sales of similar vacant parcels in the area. This is an important step, as inaccurate land values can make the entire cost approach invalid.

Finally, the property value should be measured against the market value standard established above.

This description is intended to be an overview of the CCS and the cost approach to value. For more detail on the CCS, please refer to the Arizona Department of Revenue Construction Cost Manual. For questions about obtaining previous years' costs on the Construction Cost System, please contact a member of the Construction Cost Team. For a further discussion of the cost approach, please refer to the Property Appraisal and Assessment Administration text published by the International Association of Assessing Officers.

SEGREGATED COST METHOD*

To demonstrate the segregated cost method in its simplest form, consider the following 1-story building.

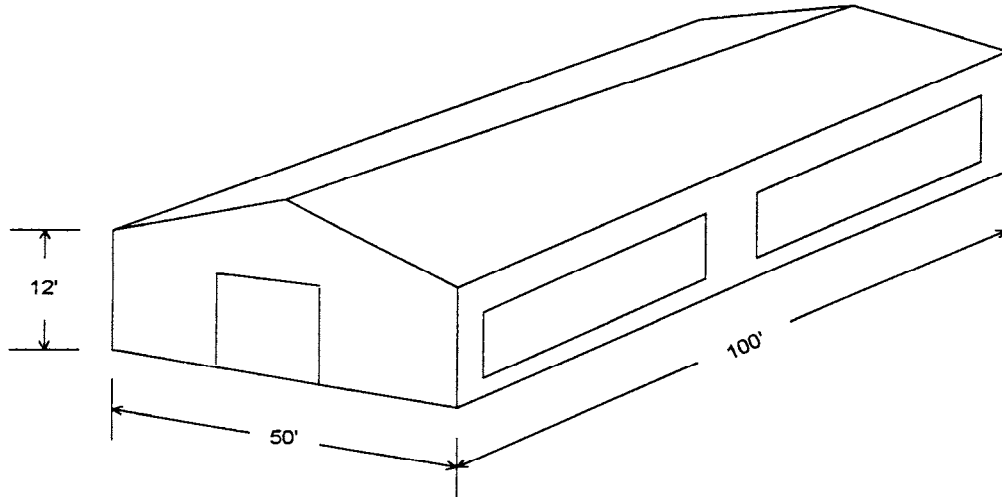

1. The building was designed to be used as an industrial building, so model number 382-3 was selected.
2. The overall quality and design are average as indicated by the number 3 in the last digit of the model number. This corresponds with a component ranking of 2 as noted below.

Cost Ranks			
1	2	3	4
Below Average	Average	Good	Excellent

3. Component cost summary:

\$	Foundation			
+	Frame			
+	Floor			
+	Electrical			
\$	Total floor area component costs	X	Floor area	= \$ Floor area cost
\$	Wall component costs	X	Wall area	= \$ Wall cost
\$	Roof structure			
+	Roof cover			
=	\$ Total roof component costs	X	Floor area	= \$ Roof cost
Floor area cost + Wall cost + Roof cost = \$ Total preliminary cost				

4. The total preliminary cost, including wall ornamentation, modified by the multipliers for the number of stories, architect's fee, current cost and locality, plus costs for miscellaneous items, will give the total replacement cost new (RCN).

*SOURCE: Marshall & Swift Valuation Service © 2000.

SEGREGATED COST METHOD*

The drawing below shows graphically how the components are segregated into major area groups for a single family residence.

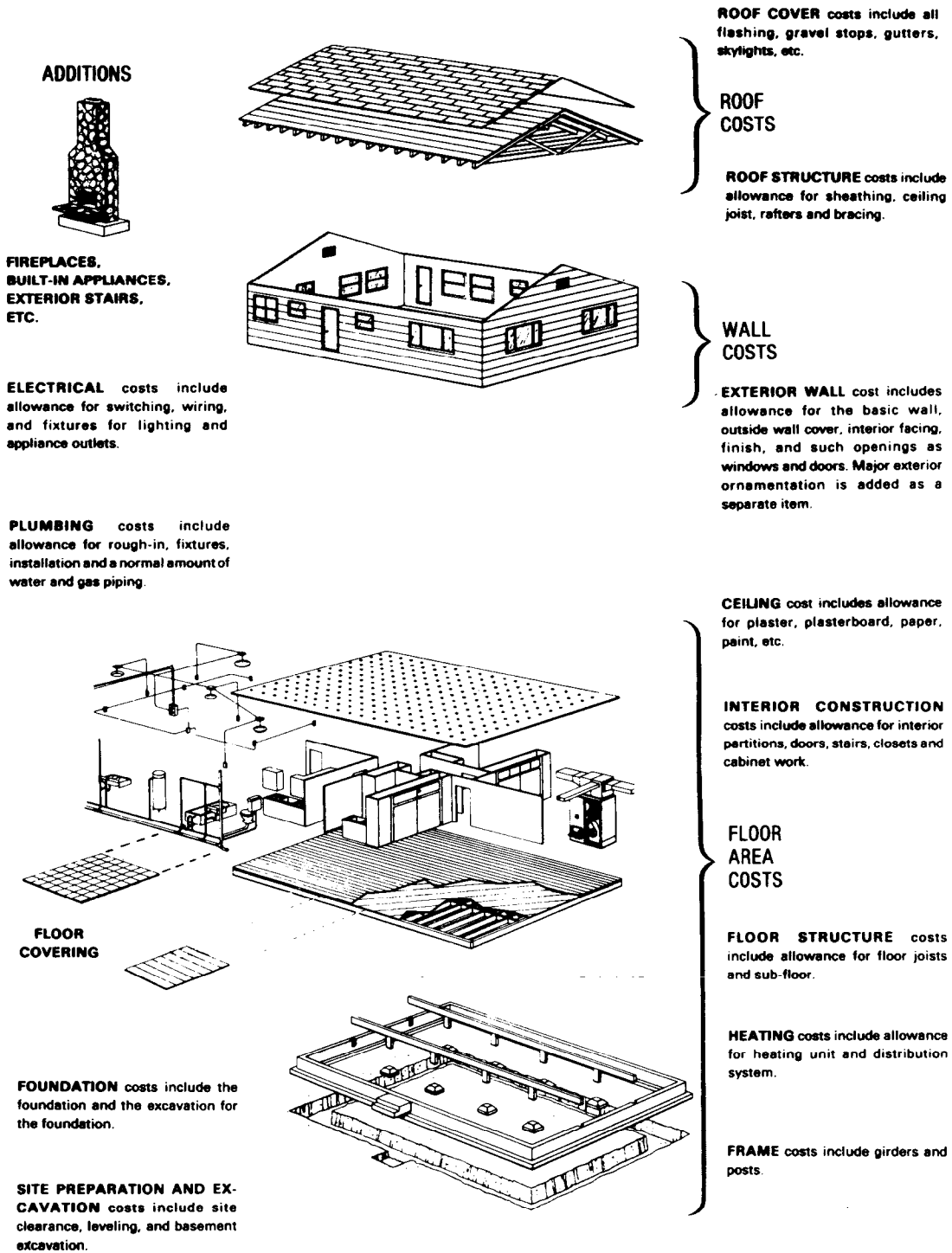

*SOURCE: Marshall & Swift Valuation Service © 2009

ORGANIZATION AND USE

The Arizona Department of Revenue (ADOR) construction cost system is flexible, easy to use, and designed to produce equitable, market-related values. The ADOR construction cost system is a fully automated cost estimating system for developing replacement cost new, local replacement cost new, depreciated values, and full cash values. It provides costs for a wide range of construction classes and types of models from single family residential to business offices to warehouses. Modifiers are provided to make the replacement costs applicable to any size structure in any location in Arizona.

The manual is organized in two volumes. The first volume contains the forms and instructions, component list, value adjustments, and models. The second has an alphabetical listing of component codes with descriptions.

The CD ROM version of the manual contains the same information as the printed manual. However, there are a number of utilities available on the CD that are not part of the printed manual. If you need a printed copy of the manual you may print one from the CD ROM version.

VALUATION CONCEPTS

The valuation concepts employed in the ADOR construction cost system are:

Reproduction Cost

Application of the reproduction cost concept requires the development of a cost estimate based on the cost to construct an improvement that duplicates the subject structure in every detail.

Replacement Cost

Application of the replacement cost concept requires the development of a cost estimate based on the cost to construct a building of like utility using modern design, materials, and workmanship.

ADOR Cost System

The ADOR construction cost system is predominantly a replacement cost system. Values generated by the application of replacement cost techniques are modified, however, to reflect significant value-adding characteristics. These characteristics include such features as clay tile roof covering, upgraded plumbing fixtures, special wall facings, and similar value-adding enhancements.

Market Value—Full Cash Value (FCV)

By statutory definition, the term full cash value (FCV) has the same meaning as market value. Market value, as defined in the IAAO Property Assessment Valuation textbook is ". . . the most probable price expressed in terms of money that a property would bring if exposed for sale in the open market in an arm's-length transaction between a willing seller and a willing buyer, both of whom are knowledgeable concerning all the uses to which it is adapted and for which it is capable of being used."

The primary objective of the ADOR construction cost system is to develop cost value estimates and FCVs compatible with market sales data. The improvement values generated by the application of the cost system, therefore, must be measured against a market standard. If a reasonably close relationship of cost and market sales-supported values exist, minimal adjustments in cost-generated

values will be required. If extensive variations exist, major adjustments may be required to meet the market standard.

Value in Use—Value in Exchange

Value in exchange is directly related to market value. The assessment process is primarily concerned with the amount of money a property will command in the marketplace. Value in use is related to the amount of money that an owner is willing to spend to build or modify real property. In most instances, an amount expended to enhance a property will result in an equivalent increase in the value of the property. In those cases where this correlation does not exist, endeavor to estimate the contribution of the enhancement on the market value of property.

VOLUME I

FORMS AND INSTRUCTIONS

Section 2 contains the various data collection forms and instructions explaining the procedure to complete them. These include:

<u>Form Number</u>	<u>Description</u>
82360	Commercial Data Collection
82360SF	Commercial Data Collection-Square Foot
82360Y	Commercial Miscellaneous Yard Improvements
82361	Residential Data Collection
82361SF	Residential Data Collection-Square Foot
82361Y	Residential Miscellaneous Yard Improvements
82362	Sketch Grid
82363	Agricultural Data Collection Form
82363Y	Agricultural Yard Improvements
82364	Improvement on Possessory Rights
82365	Golf Course Data Collection
82366	Feedlot Data Collection
82367	Permanent Crop Data Collection
82368	Mobile Home—Recreational Vehicle Parks
82369	Mobile Home Data Collection
82370	Supplemental Data Collection
82371SF	Warehouse Data Collection-Square Foot



COMPONENTS

The components are grouped into component type by building segment. For example, all foundation components are grouped in component type four and all floor structure components are listed in component type eleven.

If the model method is chosen, select the appropriate model then compare the subject structure components with the components listed for the model. Exchange components as necessary until the model represents the characteristics of the subject structure.

The components may also be used to build an improvement from ground up. This is accomplished by listing the appropriate component codes together with the number of units or percent of the structure the components represent. The system will then generate an overall improvement value.

If a component is encountered that is not included in the component section, it should be added to the component list. This is accomplished by obtaining costs from building contractors in the area where the component is used. Once the cost data is assembled, send it to the ADOR Division of Property Valuation and Equalization. A component code, including description and associated costs, will then be developed.

Components are ranked from below average to excellent based on the design, materials, and workmanship.

Cost Rank 1 is Below Average
 Cost Rank 2 is Average
 Cost Rank 3 is Good
 Cost Rank 4 is Excellent

Descriptions of component characteristics and considerations for cost rank selection are contained in Volume II. The overall final value of the structure is a weighted average of the component rankings.

Components are grouped in the following numbered component types:

<u>Component Type</u>	<u>Description</u>
02	Square Foot Components
03	Site Preparation
04	Foundation
05	Frame and Structure
06	Exterior Wall
07	Storefront
08	Wall Ornamentation
09	Roof Structure
10	Roof Cover
11	Floor Structure
12	Floor Cover
13	Interior Construction
14	Ceiling
15	Plumbing
16	Fire Protection
17	Heating, Cooling, and Ventilation Systems
18	Electrical
19	Elevators
20	Special Purpose Buildings
21	Miscellaneous Built-In Construction
22	Shopping Center Malls
23	Mezzanines and Interior Balconies
24	Reserved for future use
25	Reserved for future use
26	Residential Porch and Patio
27	Residential Exterior Balconies
28	Exterior Stairs
29	Other
30	Additional Components
31	Basement
32	Residential Garages
33	Residential Carports
34	Residential Breezeway
35	Special Components
36	Yard Improvements

VALUE ADJUSTMENTS

[Depreciation](#), location, shape, wall height, and number of stories adjustments are automatically applied by the system based on the data provided on the field data collection form.

The replacement cost new of an improvement may be adjusted for physical condition, [obsolescence](#), and modernization. Adjustments in any of these three areas must be fully justified and explained in the Remarks section.

MODELS

Build-up Method

When using the build-up method, individual components are selected and entered into the system. The final structure is an aggregate of the components selected.

Model Method

Select a model from the list of models that closely represents the subject structure. Compare the components of the selected model with components of the subject structure. Components are selected as necessary to replace the components listed for the model to reflect the subject improvement characteristics. As the components are exchanged, the replacement cost new (RCN) of the model is adjusted by the computer to reflect the characteristics, quality, and design of the subject improvement.

For both the model and build-up methods, improvements such as sidewalks, sprinkler systems, concrete pads, fences, and swimming pools are considered yard improvements. These types of improvements may be valued separately from the structure itself by using model number 100-x for residential yard improvements and model number 101-x for commercial/industrial yard improvements. The quality of these improvements need not be the same as that of the structure.

The structures may be graded for quality of design, workmanship, and materials as follows:

Below Average Quality

These buildings are generally constructed to meet the minimum building code. Little ornamentation and lack of architectural design are apparent. The interior partitioning and finishes are minimal building code and of low quality.

Average Quality

The buildings in this group make up the largest portion of construction, approximately 50 percent. Generally designed for maximum economic potential without the amenities found in higher quality construction. Ornamentation and architectural design are not elaborate. The interior partitioning and finishes are average building code construction.

Good Quality

Good quality buildings are designed for good appearance, comfort, and convenience as well as some element of prestige. Higher quality ornamental treatment and interiors are evident. Primary elements and amenities of higher costs are better lighting and mechanical work. Good quality construction is much the same as the average quality construction with these exceptions: more detail of design and higher mechanical and electrical costs.

Excellent Quality

Excellent quality structures are usually superior, prestige structures with some expensive finishes and fixtures. These will show more ornamentation, special architectural design, and top quality workmanship and materials. However, for those most luxurious structures that are built without regard for cost, the listed costs will not be high enough since each listed cost represents the average of costs within the quality range.

The models list includes representative structures from each of several improvement groupings. The groupings include:

Agricultural

Residential: Condominiums
Single Family Residences
Townhouses

Multiple Family Residential:

Duplex
Fourplex
Triplex

Commercial and Industrial:

Apartments
Industrial
Offices
Recreational
Retail Stores
Service Facilities
Warehouses

VOLUME II**COMPONENT DESCRIPTIONS**

Volume II contains an alphabetical listing of component codes with descriptive information. Any limitations or special use instructions and considerations for cost rank selection are also part of the description.

APPENDIX A—GLOSSARY

The glossary includes terms commonly used in the construction industry. It also includes terms that have specific meanings as applied to Arizona ad valorem tax functions.

APPENDIX B—MISCELLANEOUS

Abbreviations, areas and measures, and weights and measures data may be used to determine heating and cooling requirements, volume, component size, component percentages, and similar measurements used in the appraisal of real property.

**ARIZONA DEPARTMENT OF REVENUE
CONSTRUCTION COST MANUAL**

**SECTION 2
FORMS AND INSTRUCTIONS**

INSTRUCTIONS

The information contained below explains the procedure to complete the data collection forms. The format of each form is the same. The exception is that components that are unique to residential, for example, will be listed on that particular form and not necessarily on the commercial/industrial form.

PARCEL NUMBER: The parcel identifier is assigned to each parcel by the county assessor. It must be entered completely, including the check digit, before an improvement can be saved on the system.

IMPROVEMENT NUMBER: When a parcel contains several improvements, each improvement is assigned a number by the appraiser, e.g., 1, 2, 3, etc., and that number is entered here. Each parcel may contain up to 999 improvements.

SECTION NUMBER: Each improvement may be broken down into building sections, including residential improvements. This may be done if two or more sections of an improvement had different construction characteristics such as story height, type of construction, construction year, etc. Each improvement may contain up to 99 sections.

IMPROVEMENT ON POSSESSORY RIGHTS (IPR): An entry in this field indicates that the owner of the improvement is not the owner of the land. A separate tax bill must be issued. When I.P.R. ownership is indicated, a separate form, Improvement on Possessory Rights Ownership Data (DOR 82364), must be completed and attached to the appropriate field data collection form. In some situations, the land used for the I.P.R. is taxable to the I.P.R. owner. In this case the area of leased land, the unit of measure involved, and the total land value of the land must be entered. This allows the system to attach a land value to the improvement value and the notification of value and tax billing will be handled accordingly.

SITUS AND CITY: Enter the address of the property. Data not required for construction cost system. May be entered in parcel file.

APPRAISER NAME AND NUMBER: The appraiser enters his or her name, last name first, first name, and middle initial. His or her appraiser number is entered if applicable.

APPRAISAL DATE: The date of the appraisal. In most instances this will be the same date the appraisal was made.

REVIEWED BY: The supervisor's initials indicate the review and acceptance of the appraisal.

DATE: Actual date of the appraisal.

MODEL NUMBER: A four-digit number selected from the list of models. A complete list may be found in [Section 5](#). Select the model that most closely resembles the type of construction and original architectural design -- not current use -- of the subject improvement. Enter the model number in this field. The first two digits of the model number indicate original architectural design. The third digit is a subgroup indicator. The fourth digit is a quality indicator. For example, the subject property is an "A"- frame residence of average construction. The model number would be 012-3. The 01 indicates residential construction, the 2 indicates an "A"-frame, and the 3 indicates average quality construction.

The fourth digit or quality indicator corresponds to the cost rank on the component level according to the following schedule. See **GRADE** for information about fair, average and good.

<u>Overall Quality Indicator</u>	<u>Component Cost Rank</u>		
	<u>Fair</u>	<u>Average</u>	<u>Good</u>
0 and 1	0.3	0.5	0.7
2	0.7	1.0	1.5
3 and 9	1.5	2.0	2.5
4	2.5	3.0	3.3
5	3.3	3.5	3.7
6	3.7	4.0	4.3
7	4.3	4.5	4.9

SALVAGE VALUE: If the fourth digit is a 9, it indicates the improvement is salvage only. The system will automatically calculate a replacement cost new (RCN) adjusted for the location, using a 95 percent obsolescence factor applied to the RCN to create a salvage value of five percent good of the RCN. A different obsolescence factor may be used, but in no case will an obsolescence factor of less than 80 percent be accepted under the designation of salvage property.

GRADE: To the right of the four-digit model/quality indicator, a new field labeled Grade has been added. This field was added to further refine the model quality indicator. After the appraiser selects an overall quality indicator, they will also enter an F (fair), A (average) or G (good) in this field. The default entry is A (average). The appraiser's selection of a F (fair) or G (good) grade will change the default ranking of the components up or down according to the above table.

CONSTRUCTION CLASS INDICATOR (CCI): Building construction is divided into five basic groups by type of framing (supporting columns and beams), exterior walls, floors, roof structure, and fireproofing. Each group is identified by a construction class indicator; A, B, C, D, and S. When selecting a CCI, consideration should be given to the major elements of the improvement. If more than one CCI is present, enter the CCI that is the most prevalent. Described below and on the following pages are the five CCI groups.

Class A: These buildings have a structural steel frame—may or may not be fireproofed—with reinforced concrete or masonry floors and roof. These are generally high-rise buildings (four or more stories) with a curtain wall for the exterior wall.

Class B: These buildings have a reinforced concrete frame, concrete or masonry floors, and roof. These are generally high-rise buildings (four or more stories) with a curtain wall for the exterior wall.

Class C: These buildings have masonry or reinforced concrete (including tilt-up) as concrete load-bearing exterior walls with a wood or steel roof and floor structure, except for the concrete slab on grade. Low-rise (three or fewer stories) commercial/industrial and residential structures are the more common structures found in this group.

Class D: These buildings have wood or steel stud bearing walls. Use this class for all improvements not specifically included in one of the other construction classes. These buildings generally include residential, agricultural, and some commercial low-rise (three or fewer stories) structures.

Class S: These buildings are characterized by incombustible material and prefabricated structural members. The exterior wall is generally prefabricated panels or sheet siding. These are generally referred to as pre-engineered steel buildings.

CLASS "A" BUILDINGS

The primary feature of Class A buildings is the **structural steel frame**—may or may not be **fireproofed**—which may be welded, bolted, or riveted together. The fireproofing may be masonry, poured concrete, plaster, sprayed fiber, or any other type that will give a high fire-resistant rating.

The floors and roof are normally **reinforced concrete** on steel **decking** or formed slabs resting on the frame or poured so as to become integral with it. These may also be composed of prefabricated panels and may be mechanically stressed.

Exterior walls will be **curtain walls** of masonry, concrete, steel studs and stucco, or one of the many types of panels of metal, glass, concrete, and other materials. Interior partitions will frequently be of masonry or gypsum block although many movable and lightweight partitions are used.

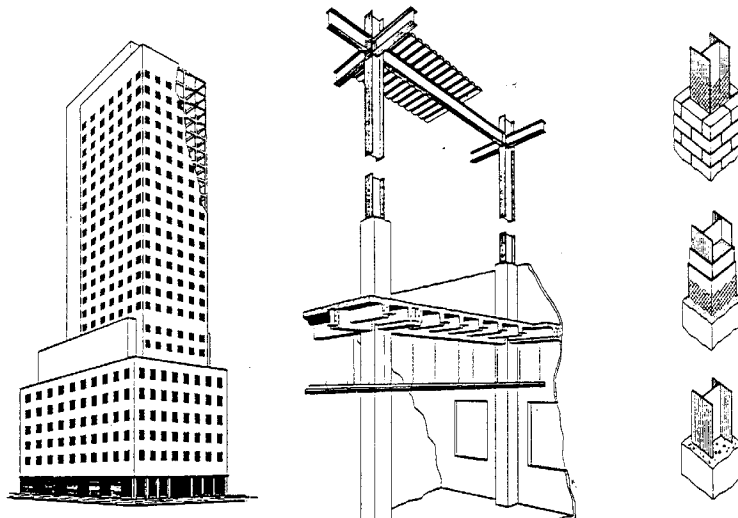

CLASS "B" BUILDINGS

The primary characteristic of a Class B building is the **reinforced concrete frame** in which the columns and beams can be either formed or **precast** concrete. These may be mechanically stressed. It is a fire-resistant structure.

The floors and roof are formed or precast concrete slabs. The exterior walls will generally be masonry or reinforced concrete **curtain walls** or any of the many types of wall panels of concrete, metal, glass, or stone. In some buildings, the exterior walls may be partially **load-bearing**. Interior partitions are often masonry, reinforced concrete, or gypsum block, but many lightweight and movable partitions are used where structural walls are not needed.

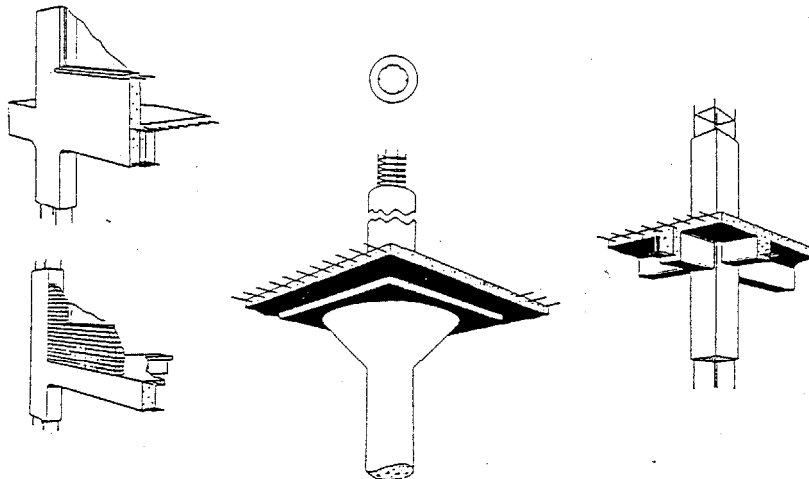
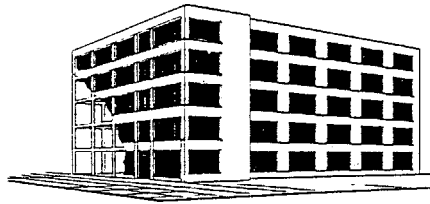

CLASS "C" BUILDINGS

Class C buildings are characterized by **masonry or reinforced concrete (including tilt-up) construction**. The walls may be load-bearing, i.e., supporting roof and upper floor loads, or non-bearing with open concrete, steel or wood columns, **bents** or arches supporting the load. The floors and roof are supported on wood or steel joists or **trusses**, or the floor may be a concrete slab on the ground. Upper floors may be of concrete plank, steel deck, or wood. Bearing walls are frequently strengthened by concrete **bond beams** and **pilasters**.

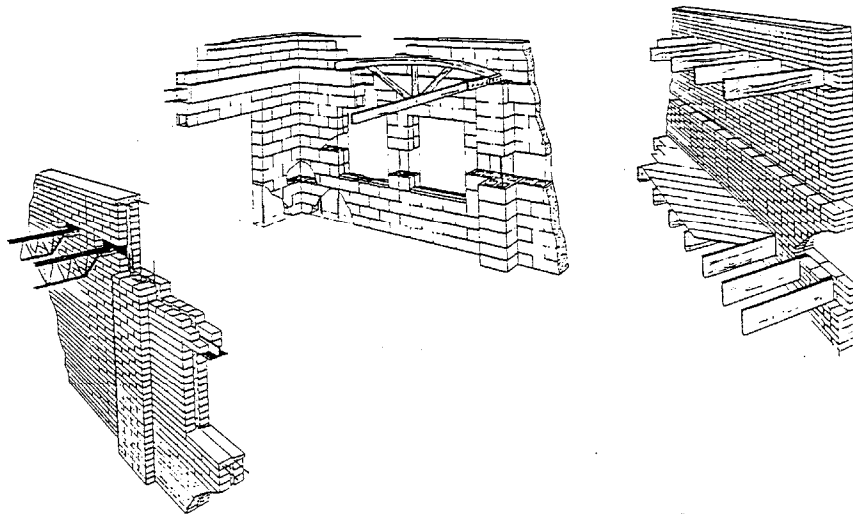
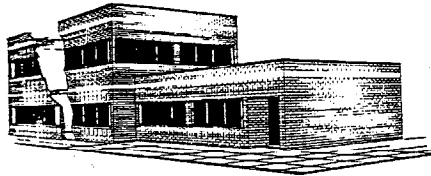
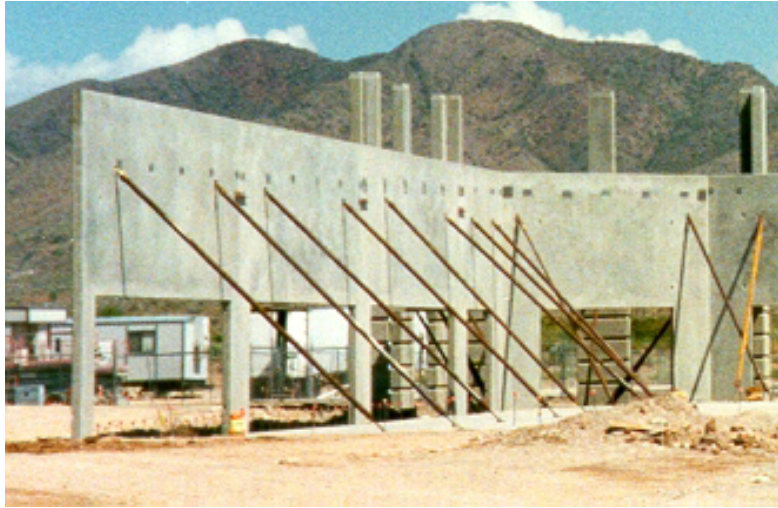

CLASS "D" BUILDINGS

Class D buildings are characterized by **combustible construction**. The exterior walls may be made up of closely spaced wood or steel studs as in the case of a typical frame house, with an exterior covering of wood siding, shingles, stucco, brick or stone veneer, or other materials. Otherwise, they may consist of an open skeleton wood frame on which some form of curtain wall is applied, including pre-engineered pole buildings.

Class D is further used to include all buildings that do not fit into any other construction class. For example, a CCI of D may be used for the following models: 083-3 (Mobile Home, Permanently Affixed), 281-3 (Mobile Home Park), and so forth.

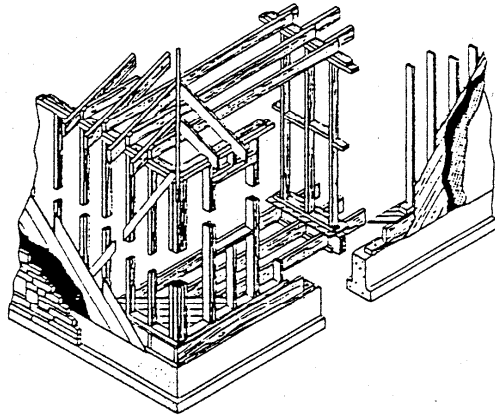
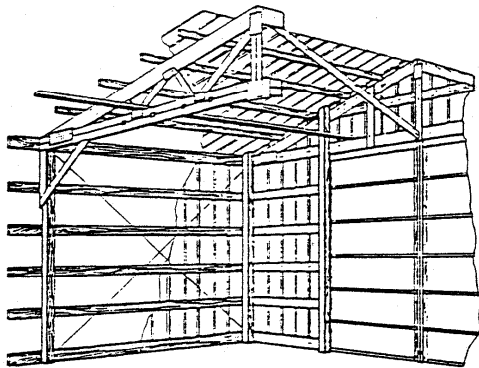
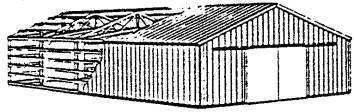

CLASS "S" BUILDINGS

Class S buildings are characterized by **incombustible construction and prefabricated structural members**. The exterior walls may be steel studs or an open steel skeleton frame with exterior coverings consisting of prefabricated panels or sheet siding. Floors and roof are supported on steel joists or beams, or the floor may be concrete slab on grade. Upper floors or roof may consist of metal deck, prefabricated panels, or sheathing.

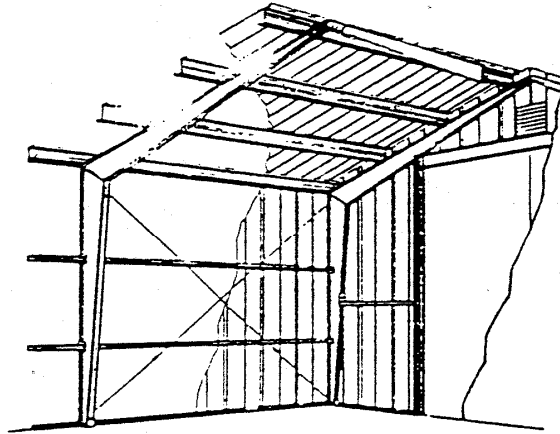
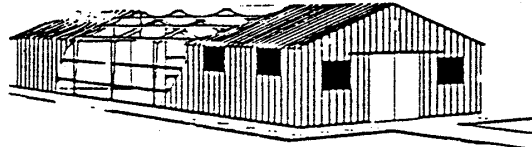

PERIMETER: Enter the perimeter of the ground floor for one-story buildings. If the upper levels of a multistory improvement have perimeters that are significantly different from the ground floor perimeter, it may be necessary to use an average perimeter. Examples 1 and 2 show the calculation for averaging the perimeter.

Example 1:

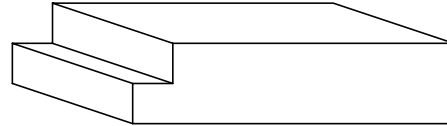
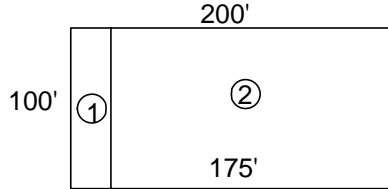

Perimeter: Ground floor 600 LF (200 + 100 + 200 + 100 = 600)
 550 LF (175 + 100 + 175 + 100 = 550)
 1150 LF ÷ 2 stories = 575 LF

THEREFORE: Perimeter: 575 LF
 Number of stories: 2

GROUND FLOOR PERIM	GROUND FLOOR AREA	TOTAL FLOOR AREA	NUMBER OF STORIES	PERCENT OWNERSHIP	AVG. STORY HEIGHT
00575	0020000	0037500	02.0	1.0000	10

Example 2:

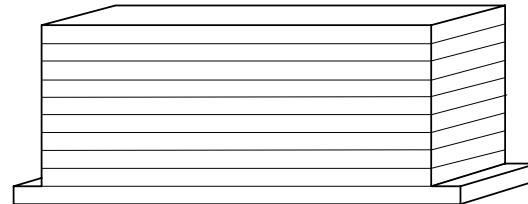
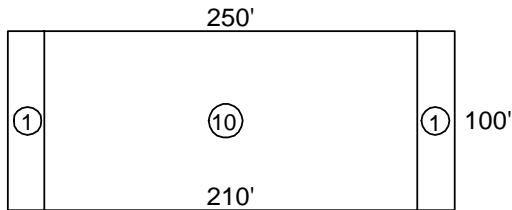

Perimeter: Ground floor 700 LF (250 + 100 + 250 + 100 = 700)
 Nine Stories 5580 LF (210 + 100 + 210 + 100 = 620 x 9 = 5580)
 6280 LF ÷ 10 stories = 628 LF

THEREFORE: Perimeter: 628 LF
 Number of stories: 10

GROUND FLOOR PERIM	GROUND FLOOR AREA	TOTAL FLOOR AREA	NUMBER OF STORIES	PERCENT OWNERSHIP	AVG. STORY HEIGHT
00628	0025000	0214000	10.0	1.0000	10

In some instances, averaging the perimeter may not be the best solution to obtain the exterior wall costs. Though the average perimeter and number of full stories is the preferred method, a second option is available as shown in Examples 3 and 4. The data required is the perimeter of each story and the average wall height to calculate the actual exterior wall area ratio for components listed in component type six (Exterior Wall).

Example 3:

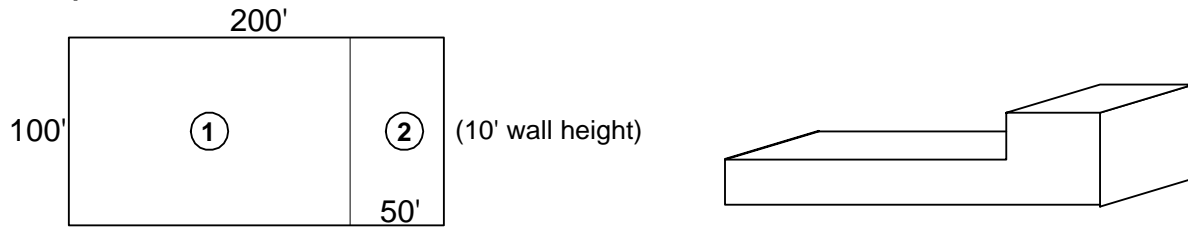

Perimeter: Ground floor 600 LF x 10' wall height = 6000 SFW
 Second story 300 LF x 10' wall height = 3000 SFW

Ratio: Second story exterior wall area to first floor exterior wall area

$$3000 \text{ SFW} \div 6000 \text{ SFW} = 0.50$$

Number of stories: 0.50 Second story
 1.00 First floor
 1.50 Number of stories

GROUND FLOOR PERIM	GROUND FLOOR AREA	TOTAL FLOOR AREA	NUMBER OF STORIES	PERCENT OWNERSHIP	AVG. STORY HEIGHT
00600	0020000	0025000	01.5	1.0000	10

Example 4:

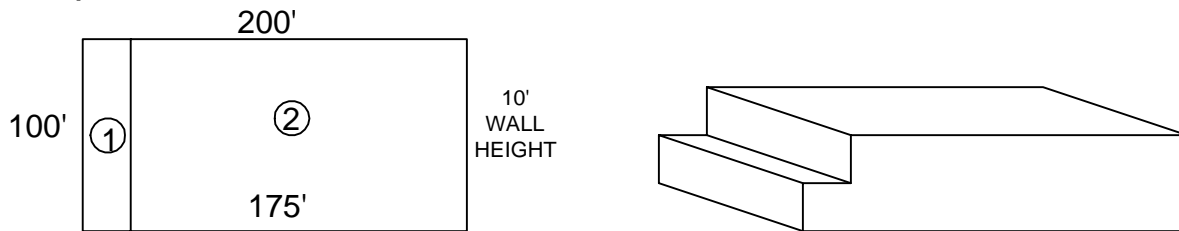

Perimeter: Ground floor 600 LF x 10' wall height = 6000 SFW
 Second story 550 LF x 10' wall height = 5500 SFW

Ratio: Second story exterior wall area to first floor exterior wall area

$$5500 \text{ SFW} \div 6000 \text{ SFW} = 0.9167$$

Number of stories: 0.9167 Second story
 1.0000 First floor
 1.9167 or 1.9 Number of stories

GROUND FLOOR PERIM	GROUND FLOOR AREA	TOTAL FLOOR AREA	NUMBER OF STORIES	PERCENT OWNERSHIP	AVG. STORY HEIGHT
00600	0020000	0037500	01.9	1.0000	10

SQUARE FOOTAGE: It is necessary to enter both the square footage of the ground floor and the total square footage of the improvement. In the case of the one-story building, these will be the same.

NUMBER OF STORIES: Enter the number of stories in the subject improvement. The system will allow up to 99.9 story configurations.

AVERAGE STORY HEIGHT: This is the average story height for the entire building (not including the [parapet](#) wall). Measure the total height of the building (1st floor to roof) and then divide by the number of stories.

Example A: Should the story heights vary in a multistory building but all the floors have approximately the same square footage, one may compute the story height as follows:

The first floor of a four-story building is 18'. Floors 2, 3, and 4 are 10' high.

$$\begin{array}{rcl} 18' \times 1 \text{ (1st story)} & = & 18 \text{ feet} \\ 10' \times 3 \text{ (2nd - 4th stories)} & = & \underline{30} \text{ feet} \\ \text{Total Height} & & 48 \text{ feet} \end{array}$$

$$\text{Average height: } 48 \div 4 = 12 \text{ feet}$$

Example B: For structures in which individual floors have different wall heights and different square footages, divide the individual floor square foot area by the total square footage of all floors. This determines the percentage of that portion of structure. Then multiply that percentage by the respective wall height and add the results to determine the average wall height for the entire structure.

1st floor has 68,000 sq. ft. with wall height of 20'
2nd thru 11th floor has 132,000 sq. ft. with wall height of 10'
12th floor has 11,000 sq. ft. with wall height of 14'
Total square footage = 211,000

$$\begin{array}{rcl} \text{1st floor has} & \frac{68,000}{211,000} & = .322 \times 20' = 6.44 \end{array}$$

$$\begin{array}{rcl} \text{2nd - 11th floor has} & \frac{132,000}{211,000} & = .626 \times 10' = 6.26 \end{array}$$

$$\begin{array}{rcl} \text{12th Floor has} & \frac{11,000}{211,000} & = .052 \times 14' = .73 \end{array}$$

$$6.44 + 6.26 + .73 = 13.43$$

Average story height rounded to whole number: 13.

CONSTRUCTION YEAR: Enter the year the improvement was built. If it is an older improvement in which remodeling has occurred it may be necessary to use an effective age. See the Assessment Practices Manual for a discussion on calculating effective age.

PERCENT COMPLETE: Used for new improvements that are not 100% complete on January 1 of each year. The system will accept entries from 10% to 90% complete. This field also accommodates damaged and destroyed improvements. An explanation in the remarks field must accompany this entry. See the Assessment Practices Manual for a discussion on damaged or destroyed properties. See [Volume 1, Appendix A](#) of this manual for a discussion on partial complete improvements.

REVIEW: If the subject improvement requires a review at a later date, enter the one-digit code. The following numeric codes are used to indicate the reason for review.

Code:

0 **No Status.** This is the default setting for the review field if no other review code is entered.

1 **Partial Complete.** Indicates the improvement is not 100% complete for the current assessment year. This code accompanies any entry in the percent complete field.

The following percentages are to be used for improvements under construction (partial complete) to determine the percent complete:

	RESIDENTIAL COMPONENTS	PERCENT OF TOTAL	CUMULATIVE PERCENT OF TOTAL
1	Plans, permits and survey	2	2
2	Excavation, forms, water/sewage hookup	4	6
3	Concrete	8	14
4	Rough framing	21	35
5	Windows and exterior doors	2	37
6	Roof cover	3	40
7	Rough-in plumbing	4	44
8	Insulation	1	45
9	Rough-in electric and mechanical	11	56
10	Exterior cover	6	62
11	Interior drywall	8	70
12	Built-in cabinets, interior doors, trim, etc.	13	83
13	Plumbing fixtures	5	88
14	Flooring covers	3	91
15	Built-in appliances	3	94
16	Light fixtures and finish hardware	2	96
17	Painting and decorating	4	100
	TOTAL	100	

	COMMERCIAL COMPONENTS		
1	Foundation	3.4	3.4
2	Frame/Structure	3.1	6.5
3	Walls	21.5	28
4	Roof	14.7	42.7
5	Floors	10.6	53.3
6	Interior	19.2	72.5
7	Plumbing	6.4	78.9
8	Heating & Cooling	9.1	88
9	Electrical	10.5	98.5
10	Other Items	1.5	100
	TOTAL	100	

2 **Damaged Property.** Signifies the improvement was damaged for the current assessment year and needs to be checked for the next year. This code accompanies an entry in the percent complete field. To value damaged property, refer to the DOR Assessment Procedures Manual.

-
- 3 **Destroyed Property.** Signifies the improvement was destroyed for the current assessment year and needs to be checked for the next year. This code accompanies an entry in the percent complete field. To value destroyed property, refer to the DOR Assessment Procedures Manual.
- 4 **Needs Relisting.** Indicates the improvement has changed and needs to be reviewed for the next assessment year.
- 9 **Special Construction.** Indicates the listing of the improvement includes the Special Construction Component, **SCO**. The cost for this component is not automatically updated by the Construction Cost System and must be trended annually by the Assessor.

5 thru 8 -- Reserved for future use.

PERCENT OWNERSHIP: This field is used where the ownership of an improvement is less than 100 percent, as in a condominium. The system will accept .0001 through 1.0000. For a complete discussion of condominium listing procedures, see [Volume 1, Appendix A](#).

OBSOLESCENCE, MODERNIZATION, AND PHYSICAL CONDITION ADJUSTMENTS

If an adjustment is made in any one of the next three fields; i.e., obsolescence, modernization or physical condition, it will be necessary that a complete explanation be given for the adjustment. The system will not accept and process the data until the entry is made. If more than one of these fields is used, a separate explanation for each is required.

Obsolescence: Enter the percentage amount of any functional or economic obsolescence that might affect the subject improvement. See the I.A.A.O. textbook for a complete discussion of obsolescence. An explanation in the remarks field must accompany this entry. The explanation must be preceded by the characters—**OBS**:

Modernization: Enter the percentage amount of modernization that has occurred on the improvement. This will always be more than 100%. Only enter the percentage over the 100% to reflect the modernization that has taken place.

Do **not** adjust the effective age of the improvement because of modernization then make an entry in this field for the same modernization. One method only should be utilized, but not both. Using both would result in an erroneously calculated improvement value. An explanation in the remarks field must accompany this entry. The remarks must be preceded by the characters—**MOD**:

Physical Condition: Enter the percentage adjustment above or below the normal depreciation level to account for the physical condition of an improvement. Do not confuse this adjustment with normal depreciation. The physical condition can be adjusted in increments of 5 percent to a maximum of plus or minus 15 percent. An explanation in the remarks field must accompany this entry. The explanation must be preceded by the characters—**PHY**:

**ARIZONA DEPARTMENT OF REVENUE
CONSTRUCTION COST MANUAL**

**SECTION 3
COMPONENT TYPES**

LIST OF COMPONENT TYPES

Component Types	1
Square Foot (2).....	2
Site Preparation (3)	2
Foundation (4)	3
Frame and Structure (5)	5
Exterior Walls (6)	9
Storefront (7)	14
Wall Ornamentation (8)	16
Roof Structure (9)	17
Roof Cover (10)	21
Floor Structure (11)	22
Floor Cover (12)	23
Interior Construction (13)	24
Ceiling (14)	29
Plumbing (15)	30
Fire Protection (16)	32
Heating, Cooling, and Ventilation Systems (17)	33
Electrical (18)	35
Elevators (19)	36
Special Purpose Buildings (20)	39
Miscellaneous Built-in Construction (21)	42
Shopping Center Malls (22)	44
Mezzanines and Interior Balconies (23)	45
Reserved for Future Use (24)	
Reserved for Future Use (25)	
Residential Porch or Patio (26)	46
Residential Exterior Balconies (27)	47
Exterior Stairs (28)	48
Other (29)	49
Additional Components (30)	55
Basements (31)	56
Residential Garage (32)	57
Residential Carport (33)	59
Residential Breezeway (34)	59
Special Components (35)	60
Yard Improvements (36)	61

COMPONENT TYPES

Buildings are separated into segments that are grouped by component type. Each group contains a description of items included in the component cost, any restrictions that may apply, a square foot of floor component or alternate component selection, and instructions for selecting certain factors, e.g., slope factors for roof structure and cover.

The component information includes:

1. Component code—may contain up to four alpha and numeric characters.
2. Brief description.
3. Unit of measure—shown in parenthesis—in which the component must be listed. The abbreviations are:

SF	Square feet of floor area
SFW	Square feet of wall area
LF	Linear feet
CF	Cubic feet
EA	Each or number of

Some components require the size or capacity. An example would be a 30,000-bushel concrete block silo. The entry shows 30,000 in the units field. A separate entry is required for each silo.

The unit of measure information may also contain the abbreviation—ADD—to indicate that this component must be used in addition to another component. If a component requires a cost rank adjustment, the term—rank table—will be noted. The rank selection table provided for that particular component must be used.

4. Other notes for some components are:
 - a. Restricted to a specific model group
 - b. Restricted to a specific model
 - c. Restricted to a specific building construction class
 - d. Additional data required such as wall thickness for masonry exterior walls

SQUARE FOOT (2)

These components are to only be used in conjunction with the square foot system.

0101 thru 6 and 9, Single Family Home	120X	Drugstore
0122 thru 6 and 9, "A" Frame Home	130X	Mall Anchor Department Store
0132 thru 6 and 9, Log Home	131X	Department Store
0142 thru 6 and 9, Dome Home	132X	Discount Store
0152 thru 6 and 9, Rammed Earth Home	133X	Warehouse Discount Store
0162 thru 6 and 9, Earth Sheltered Home	134X	Mega-Warehouse Discount Store
0172 thru 6 and 9, Envelope Home	141X	Neighborhood Shopping Center
0182 thru 6 and 9, Specialty Home	142X	Community Shopping Center
0192 thru 6 and 9, Hillside Home	143X	Regional Shopping Center
0201 thru 6 and 9, Single Family Home, Multi- Story	144X	Neighborhood Shopping Center-Shell Only
0281 thru 6 and 9, Factory/Site Built Home	145X	Community Shopping Center-Shell Only
0321 thru 5 and 9, Duplex	146X	Regional Shopping Center-Shell Only
0332 thru 5 and 9, Triplex	151X	Business Office
0342 thru 5 and 9, Fourplex	152X	Business Office, First Floor Parking
035X Apartment (3 or less stories)	153X	Business Office-Shell Only
036X Apartment (4 or more stories)	154X	Business Office, 1 st Floor Parking- Shell Only
037X Retirement Apartments	161X	Central Bank
038X Assisted Living Apartments	162X	Branch Bank
041X Hotel	176X	Mini-Lube Garage
042X Dormitory	178X	Automotive Repair
043X Hotel, Full Service	179X	Auto Parts and Service
044X Hotel, Limited Service	201X	Restaurant, Full Service
051X Motel	202X	Restaurant, Fast Food
060X Day Care Center	203X	Cocktail Lounge
0702 thru 6 and 9, Condo–Townhouse (Entire Bldg)	204X	Bar–Tavern
0712 thru 6 and 9, Condo–Townhouse (Inside Unit)	205X	Truck Stop
0722 thru 6 and 9, Condo–Townhouse (End Unit)	210X	Medical–Dental Clinic, First Floor Parking
102X Laundry Building	211X	Medical–Dental Clinic
103X Rest Room Building	212X	Veterinary Clinic
104X Depot	213X	Hospital
105X Guardhouse	214X	Nursing Home
110X Laundromat–Dry Cleaning Plant	215X	Emergency Medical Dispensary
111X Retail Store	216X	Surgical Center
112X Supermarket	220X	Mortuary
113X Convenience Market	251X	Theater, Walk-in
114X Strip Store	271X	Lodge
115X Vehicle Sales	272X	Clubhouse
116X Barber–Beauty Shop	273X	Health Club
117X Warehouse Food Store	274X	Handball–Racquetball Club
118X Warehouse Showroom Store	275X	City Club–"Y"
119X Mini-Mart Convenience Market		

276X	Bowling Alley
277X	Country Club
278X	Skating Rink
291X	Parking Garage, Above Grade
292X	Parking Garage, Below Grade
370X	Warehouse, Transit
371X	Warehouse, Storage
372X	Warehouse, Distribution
373X	Mini-Storage
374X	"T" Hangar, Aircraft
375X	Industrial Flex Building
376X	Aircraft Storage Hangar
377X	Warehouse, Cold Storage
378X	Covered Storage, Commercial– Industrial
379X	Mega-Warehouse
380X	Lumber Storage, Horizontal
381X	Equipment Maintenance–Storage
382X	Industrial Manufacturing
384X	Industrial Manufacturing-Medium
385X	Industrial Engineering
386X	Industrial Light Manufacturing
387X	Industrial Heavy Manufacturing
388X	Industrial Building-Shell Only
400X	Labor Dormitory–Bunk House
401X	Dairy
405X	Poultry House
408X	Hog Finishing–Farrowing Barn
412X	Cotton Gin
450X	Produce Packing Barn
451X	Barn
452X	Agricultural Utility Building
453X	Horse Arena
454X	Hay Shed–Livestock Shelter
455X	Horse Stable
900X	Post Office
901X	Courthouse
902X	Library
903X	Church
904X	Fire Station
905X	Prison / Correctional Facility
906X	Elementary School (All Buildings)
907X	Secondary School (All Buildings)

SITE PREPARATION (3)

Costs include bulk excavation and fill (BA–BB), and clearing and site grading (BC). In almost every case, the component code BC (site preparation) should be used. This includes the cost for normal site preparation for the building area only and is entered as a percentage of ground floor area of the building (usually 100%). When considering site preparation for the site itself, the costs for items to make the site buildable such as fill, caissons, retaining walls and so forth, are reflected in the land value.

BA	Excavation (CF)
BB	Fill (CF)
BC	Site preparation (SF ground floor area)

Costs for trenching foundations or footings are included with the foundation costs.

If an improvement has a basement, ADD for excavation from this component type. Backfill is included in BA (Excavation) costs. **Do not use** BC for the portion of the building that has a basement under it.

For a dock-height floor, it will be necessary to account for the extra fill by adding BB (Fill). However, the component code **DOF** (Dock-Height Floor) may be used. Costs for DOF include the fill. It is listed in component type 29 (Other).

Use component code BC in conjunction with commercial parking lots of 100,000 square feet or more which are paved with asphalt or concrete.

Excavation Calculation Example:

Structure: 20' x 40'

Overdig: 3 feet minimum all sides

Depth: 8 feet

$$(20+3+3) (40+3+3) \times 8 =$$

$$26 \times 46 \times 8 = 9,568 \text{ CF}$$

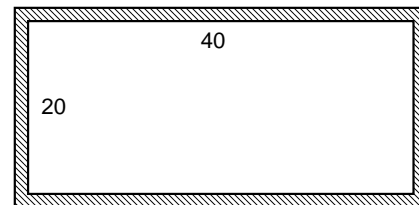

3' OVERDIG EACH SIDE

FOUNDATION (4)

Foundation costs, depending on component, include concrete or masonry **piers**, footings, or pads that support posts or columns, continuous footings, monolithic pour foundations or foundation stem walls. Trenching, excavation, and backfill costs for the footings are included.

There are two options for listing the foundation: using a square foot of floor area component or an alternate component (linear feet or number of columns). The square foot of floor components are best used for buildings where the foundation is closely related to the floor area (fully framed multistory buildings) or with buildings having a high proportion of interior construction (apartments, residences, hospitals). The alternate components are best used for large shell type buildings (over 13,000 square feet) where the foundation is more closely related to the perimeter, e.g., warehouses and industrial buildings. The perimeter footing should be listed by the **lineal foot** using component **CC** on classes C and S or **CCE** on class D. In addition, the individual column footings should be listed per column using component **CEA** for class S. Use components **CD** or **CE** for classes C and D.

CAC may be used for Class S buildings that have a light foundation and **up to** 13,000 square feet of floor area.

Basement foundations are listed separately from the structure. Subtract 1 from the overall cost rank for both the basement and structure foundations. For example, if the overall building cost rank is 3, then the cost rank is 2 for both the basement and structure foundations.

CAUTION—Use either square foot of floor area components or alternate components. **Do not** mix the two methods.

Soil Bearing Capacities

Both the square foot of floor area components and the alternate components are to be adjusted for the soil bearing capacity of the area. Check the soil-bearing map in the soil map booklet. Locate the improvement in one of the color bearing areas. The map key color will show the designator to use—**X (light)**, **Y (medium)**, or **Z (heavy)**. This designator is then appended to the component in either the third or fourth character position to complete the component code. Thus, CAB or CA located in a medium soil bearing capacity area becomes CABY, or CA becomes CAY.

Square Foot of Floor Area Components

Cost includes perimeter and interior foundations typical of a load-bearing or fully framed structure for the model and quality selected.

Continuous Footings

CAB	Concrete bearing wall (SF) Class C. May be used for the bearing wall portion of a Class A, B, C, or S partially framed building.
CA	Concrete nonbearing wall (SF) Generally Class A and B
CAF	Concrete masonry veneer (SF) Class D
CAC	Concrete, open shell type (SF) Class C, D, and S
CAD	Concrete, pole type (SF) Class D
CAE	Concrete, siding or stucco (SF) Class D
CJ	Masonry (SF) Class C, D, and S
CK	Masonry block (SF) Class C, D, and S
CAG	Treated wood, masonry veneer (SF) Class D—residential and farm buildings only.
CAH	Treated wood, siding or stucco (SF) Class D—residential and farm buildings only.

FOUNDATION (4)

Column Footing Foundations

- CEB** Concrete column footing, steel column, pre-engineered (SF) Class C, D, and S—farm buildings only.
- CDC** Concrete column footing, wood column (SF) Class C and D—farm buildings only.
- CDB** Concrete column footing, wood column (SF) Class D—farm buildings only.
- CDD** Piers, concrete footing (SF) Class D—residential and farm buildings only.
- CB** Wood blocks and sills (SF) Class D—residential and farm buildings only.

Alternate Components

Use with low rise Class C, D, and S shell type construction having minimal interior construction.

Continuous Foundations

- CC** Concrete (LF) Class C, D, and S
- CCF** Concrete, masonry veneer (LF) Class D
- CCE** Concrete, siding or stucco (LF) Class C, D, and S
- CCJ** Light reinforced grade beams (LF) Class C, D, and S
- CCG** Treated wood, masonry veneer (LF) Class D—residential and farm buildings.
- CCH** Treated wood, siding or stucco (LF) Class D—residential and farm buildings.
- CCK** Unreinforced grade beam (LF) Class C, D, and S
- CBA** Wood sills (LF) Class D—farm buildings only.

Concrete Column Footings

- CF** Concrete column footing, concrete column (EA) Class C
- CE** Concrete column footing, steel column (EA) Class C, D, and S
- CEA** Concrete column footing, steel column, light pre-engineered (EA) Class C, D, and S
- CD** Concrete column footing, wood column (EA) Class C and D
- CDA** Concrete column footing, wood column, light pole (EA) Class D
- CDE** Piers, concrete footing (EA) Class D—residential and farm buildings only.

ADD—Use in addition to any alternate component selected above.

- CL** Insulation (ADD; LF)

FRAME AND STRUCTURE (5)

Costs for the frame and structure include [posts](#), [columns](#), [beams](#), [girders](#), [sills](#), [underpinning](#), and bracing, which are the primary means of support for the building.

The two options for pricing the frame and structure are using square foot of floor area components or alternate (linear foot) components. Use square foot of floor area components for fully framed buildings. The alternate components utilize individual columns and beams. Cost rank adjustment should be considered when using the alternate method. Instructions for determining the percentage of the frame and structure for partially framed buildings follow the component listing and rank tables.

CAUTION—**Do not** mix square foot of floor components with alternate components.

Square Foot of Floor Area Components

Square foot of floor area components are based on a frame assembly typical for the model and quality selected, and provides sufficient load bearing to support the floor and roof assemblies.

DC	Concrete, reinforced (SF) Class B
DB	Floor supports (SF)
DBA	Floor supports, masonry (SF) Class C, D, S—farm buildings.
DH	Laminated bents and arches (SF)
DV	Steel columns, wood beams (SF) Class C and D
DNA	Steel, Class S, light pre-engineered (SF)
DI	Steel, fireproofed (SF) Class A
DJ	Steel, not fireproofed (SF) Generally Class C and D
DU	Wood "A"—frame (SF) Class C and D
DK	Wood posts and beams (SF)
DP	Wood, light pole type (SF) Class D
DL	Wood, mill type (SF) Class C

Alternate Components

Commercial

For use with low rise Class C, D, or S shell type construction having minimal interior finish.

DO	Pipe columns (LF—Rank Table)
DM	Reinforced concrete members (LF—Rank Table)
DG	Steel frame members (LF—Rank Table)
DF	Wood frame members (LF—Rank Table)

Residential

DS	Concrete frame members (LF)
DT	Pipe columns (LF)
DR	Steel frame members (LF)
DQ	Wood frame members (LF)

FRAME AND STRUCTURE (5)

RANK SELECTION TABLES

DF Wood Columns and Beams

SIZE (Inches)	RANK Timber	RANK Glu-lam	SIZE (Inches)	RANK Timber	RANK Glu-lam
4 x 4	1.0	1.7	10 x 10	2.4	2.6
4 x 8	1.5	2.0	10 x 20	2.9	3.0
4 x 12	1.8	2.2	10 x 30	3.3	3.2
4 x 16	2.2	2.4	12 x 12	2.7	2.8
6 x 6	1.6	2.1	12 x 24	3.2	3.2
6 x 10	2.0	2.3	12 x 36	3.5	3.5
6 x 14	2.2	2.5	14 x 14	2.9	3.0
6 x 20	2.5	2.7	14 x 28	3.4	3.4
8 x 8	2.0	2.4	14 x 42	3.8	3.7
8 x 12	2.3	2.6	16 x 16	3.1	3.2
8 x 16	2.6	2.7	16 x 32	3.7	3.6
8 x 24	2.9	2.9	20 x 26	4.0	3.9

DG Steel Beams and Columns

H Beams

SIZE		SIZE	
4 x 4	1.9	12 x 12.00	4.0
5 x 5	2.3	14 x 14.50	4.2
6 x 6	2.6	18 x 11.75	4.3
8 x 8	3.1	24 x 14.00	4.7
10 x 10	3.6	30 x 15.00	5.1

I Beams

SIZE		SIZE	
3	1.0	12	3.1
4	1.4	14	3.3
6	2.1	16	3.5
8	2.5	20	3.7
10	2.8	24	4.0

DM Concrete Columns

SIZE		SIZE	
12	2.4	24	3.3
14	2.6	28	3.5
16	2.7	32	3.7
18	2.9	36	3.9
20	3.1	—	—

DM Concrete Beams

SIZE		SIZE	
4 x 6	1.0	10 x 18	2.5
6 x 8	1.6	12 x 16	2.6
8 x 10	2.0	12 x 20	2.9
10 x 12	2.3	12 x 24	3.0

DO Pipe Columns

SIZE (Inches)	ROUND	SQUARE
3	1.4	2.0
4	2.3	2.6
6	3.3	3.7

FRAME AND STRUCTURE (5)

Partially Framed Buildings

When a building has a combination of frame and bearing walls, it is more accurate to first price the bearing walls with pilasters and bond beams and then price the frame on the basis of the area supported by the frame, or to price the columns and girders separately.

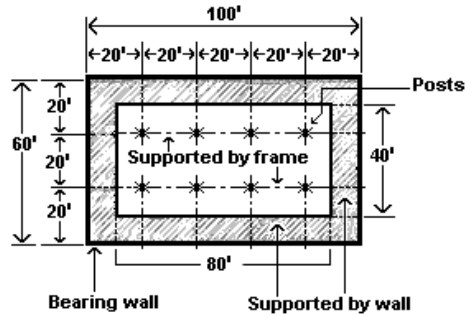

In the drawing to the left, it is assumed that each wall supports the roof halfway to the posts or columns (as shown by the shaded area) and the balance is supported by the frame.

Area supported by frame: 40 feet x 80 feet = 3,200 square feet
 Total area supported by walls and frame: 60 feet x 100 feet = 6,000 square feet
 Percentage of total supported by frame: 53%

If the frame component used in this example is DI (Fireproofed Steel), the entries on the data collection form are DI and 53%, indicating that the frame cost for DI is applied to 53% of the total floor area.

If the exact proportion is difficult to determine using the method shown above, the following table can be used. The distances listed are the shortest dimensions between bearing walls.

Shortest Distance (Feet)	Percent of Floor Area	Shortest Distance (Feet)	Percent of Floor Area
30	30	70	58
35	35	75	60
40	40	80	63
45	45	85	66
50	50	90	70
55	52	100	71
60	54	110	73
65	56	120>	75

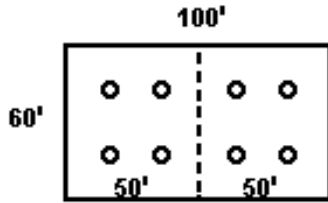
FRAME AND STRUCTURE (5)**Partially Framed Buildings (continued)**

For example, the building in the drawing to the left is 60 feet by 100 feet without interior walls. Thus the shortest dimension is 60 feet.

From the table: 50-foot span, use 50% of full frame cost
75-foot span, use 60% of full frame cost
By interpolation: 60-foot span, use 54% of full frame cost

If there is an interior bearing wall such as shown by the broken line, the shortest dimension is 50 feet so 50% of the full frame cost is used.

EXTERIOR WALL (6)

Costs for the exterior wall include the basic wall, windows, doors, exterior wall finish, and interior wall covering where applicable. Walls are grouped by type of construction. These include masonry walls, [curtain walls](#), wood or steel stud walls, single wall, and agricultural single wall construction. The amount and quality of doors, windows, and wall finishes should be considered when selecting the appropriate cost rank for each component. For commercial buildings with [storefronts](#), use components from [component type 7](#) (Storefront).

Masonry Walls

Most masonry wall components require an entry for the wall thickness. The thickness range is noted with each component. This data is entered in the miscellaneous column.

XU	Adobe (SFW) 6"-12" Class A, B, and C
XUM	Adobe, mud (SFW)
MCG	Brick, 6" SCR modular (SFW)
MB	Brick, block back-up (SFW) 6"-36"
MD	Brick, cavity (SFW) 4"-36"
XZ	Brick, cavity, block back-up (SFW) 4"-36"
MC	Brick, common (SFW) 4"-36"
XV	Clay block, hollow (SFW) 6"-12"
MZ	Clay tile (SFW) 4"-36"
XW	Concrete block, cavity (SFW) 6"-12"
XY	Concrete block, cavity slump stone (SFW) 6"-36"
XX	Concrete block, slump stone (SFW) 6"-36"
MG	Concrete block, standard (SFW) 6"-36"
WY	Stucco on standard block (SFW) 6"-36"
WZ	Stucco on cavity block (SFW) 6"-36"
XA	Concrete, precast (SFW) 4"-14"
MR	Concrete, reinforced (SFW) 4"-36"
MH	Concrete, tilt-up (SFW) 4"-36"
MBV	Glass block wall (SFW)
XG	Granite (SFW) 6"-36"
MICF	Insulating Concrete Form Wall (SFW)
XH	Limestone (SFW) 6"-36"
XJ	Marble (SFW) 6"-36"
WW	Rammed earth, commercial (SFW) 18"-36"
WX	Rammed earth, residential (SFW) 18"-36"
MJ	Stone rubble (SFW) 4"-36"
MI	Stone, ashlar veneer block (SFW) 6"-36"
XI	Stone, local (SFW) 6"-36"

Buttresses

XB	Buttress, brick (CF buttress area)
XBA	Buttress, concrete (CF buttress area)
XC	Buttress, granite (CF buttress area)
XD	Buttress, limestone (CF buttress area)
XE	Buttress, local stone (CF buttress area)
XF	Buttress, marble (CF buttress area)

EXTERIOR WALL (6)

ADD—Use in addition to any component selected above:

ML	Bond beams (ADD; SFW)
MEA	Face block (ADD; SFW)
ME	Face brick (ADD; SFW)
MAB	Facing tile (ADD; SFW, per side)
MM	Insulation (ADD; SFW)
MK	Pilaster (ADD; SFW)
MFB	Stay-in place frame, below grade (ADD; SFW)
MBU	Synthetic plaster on rigid insulation (ADD; SFW)

Curtain Walls

Curtain walls are not load bearing. This type of construction is common in high-rise commercial buildings (four or more stories). A selection from [component type 5](#) (Frame and Structure) is required.

MX	Bronze and glass (SFW)
MU	Concrete and glass panel (SFW)
MYC	Marble panel (SFW)
MYG	Masonry and glass panel (SFW)
MV	Metal and glass panel (SFW)
MW	Stainless steel and glass (SFW)
MAA	Steel studs and stucco (SFW)
MY	Stone panels (SFW)
MYD	Synthetic plaster on rigid insulation (SFW)
MYH	Wood and glass panel (SFW)

ADD—Use in addition to any component selected above:

MAC	Insulation for curtain walls (ADD; SFW)
-----	---

Wood or Steel Stud Walls (May be load bearing)

MBN	Asphalt siding (SFW)
MCF	Hardboard sheet siding (SFW)
MAG	Shakes, wood (SFW)
MAF	Shingles, wood (SFW)
MAD	Siding, aluminum (SFW)
MAE	Siding, asbestos (SFW)
MCB	Siding, hardboard (SFW)
MAQ	Siding, textured plywood (SFW)
MAP	Siding, vinyl (SFW)
MAJ	Siding, wood (SFW)
MAH	Stucco (SFW)
MAI	Stucco with sheathing (SFW)
MCC	Synthetic plaster on rigid insulation (SFW)
MAL	Veneer, common brick (SFW)
MCH	Veneer, face block (SFW)
MAM	Veneer, face brick (SFW)
MAN	Veneer, stone (SFW)

EXTERIOR WALL (6)

ADD—Use in addition to any component selected above.

MCE	Air infiltration wrap (ADD; SFW), Residential
MAU	Insulation (ADD; SFW)
MBR	Sheathing (ADD; SFW)

Single Wall Construction (Wood or Steel Framed Walls)

These walls are not load bearing. A selection from [component type 5](#) (Frame and Structure) is required for all non-load-bearing walls.

MAY	Metal cover, steel frame (SFW)
MAZ	Metal cover, wood frame (SFW)
MBJ	Sandwich panel, asbestos cement, 2 sides (SFW)
MBH	Sandwich panel, glass exterior, metal interior (SFW)
MBP	Sandwich panel, metal, 2 sides (SFW)
MBW	Sandwich panel, metal, 2 sides, cold storage (SFW)
MBK	Sandwich panel, steel exterior, gypsum board interior (SFW)
MBB	Siding, wood frame (SFW)
MEE	Stucco, wood frame (SFW)
MBA	Transite, steel frame (SFW)

ADD—Use in addition to any component selected above.

MBT	Insulation (ADD; SFW)
MBS	Sheathing, exterior (ADD; SFW)
MBC	Sheathing, interior, finished (ADD; SFW)

Single Wall Construction (May be load bearing)

MAS	Log, rustic (SFW)
MSTR	Straw bale (SFW)

Farm Single Wall Construction

MEB	Asbestos, wood frame (SFW)
MEC	Asphalt siding, wood frame (SFW)
MED	Fiberglass, wood frame (SFW)
MEG	Spaced boards (SFW)
MEF	Boards over 1 inch (ADD; SFW)

Service Station Components

Masonry Walls

MP	Brick (SFW)
MQ	Concrete block (SFW)
MS	Steel panels, block back-up (SFW)

Single Wall Construction

MSR	Steel and glass painted (SFW)
MSP	Steel and glass porcelainized (SFW)

EXTERIOR WALL (6)

Exterior Overhead Doors

Exterior wall area entered for other components in this type should not include overhead door area entered for the following components.

ODF	Overhead door, fiberglass (SF of door area)
ODS	Overhead door, steel (SF of door area)
ODW	Overhead door, wood (SF of door area)
ODG	Steel gate (SF of gate area)

Hangar Doors

For the following components, deduct the square feet of door from the square feet of exterior wall area.

MDA	Steel hangar door (SF of door)	Up to 20 feet high
MDB	Steel hangar door (SF of door)	20 feet to 40 feet high
MDC	Steel hangar door (SF of door)	Over 40 feet high

Greenhouse Walls

MGA	Curtain, automatic sidewall assembly (LF of curtain)
MGB	Masonry stem wall (LF)

Self-Serve Car Wash

MWA	Masonry partition (SFW or partition area)
MWB	Steel partition (SFW or partition area)
MWC	Wood frame or stucco (SFW or partition area)

Security Shutters

MSEC	Rolling security shutters (SFW of window area)
MOTR	Motorized shutter operator (UN number of units)

EXTERIOR WALL (6)

Dome Homes (014-x) are typically purchased as kits from a manufacturer. The interior finish is minimal. The dome is erected on a minimal foundation with a wood subfloor or a concrete slab on grade. Wall construction may be panels or sections of wood or styrofoam, or may be steel frame or balloon type with concrete and foam sprayed in place. Use the appropriate component codes for the entire dome surface area. To calculate the square feet of surface area, do the following 3-step procedure:

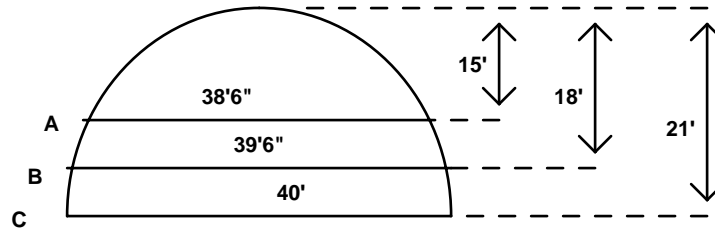

- Step 1: To determine the total surface area of the sphere:
Multiply the widest portion of the dome (diameter) by the circumference (perimeter).
- Step 2: To determine that fractional portion of the sphere represented by the dome:
Divide the height (floor to top center) by the diameter.
- Step 3: To determine the square feet of the dome surface area:
Multiply surface area of sphere by the fractional portion.

	<u>Step 1</u>	<u>Step 2</u>	<u>Step 3</u>
a.	$38.5 \times 121 = 4,657$	$15 \div 38.5 = 0.39$	$4657 \times 0.39 = 1,816$ SFW
b.	$39.5 \times 124 = 4,902$	$18 \div 39.5 = 0.46$	$4902 \times 0.46 = 2,234$ SFW
c.	$40.0 \times 126 = 5,027$	$21 \div 40.0 = 0.53$	$5027 \times 0.53 = 2,639$ SFW

STOREFRONT (7)

The component costs include the display platform or any special floor required by the front, ornamentation, dropped display or entrance ceilings, bulkheads, lighting, and the sign area. Examples of storefronts are shown on the [following page](#).

The wall area for other wall types should not include the storefront. Use OD, OB, or OG in conjunction with exterior wall components for retail stores, convenience markets, strip stores, department stores, discount stores, and shopping centers. Example: In a 4-sided strip center, 3 sides would be selected from component type 6 (Exterior Wall), and one side would be the selected storefront from this list.

Air Curtain

- HQA Air curtain (SF of entrance opening)
- HQB Air curtain, heat-filtered (SF of entrance opening)

Storefront-Exterior Wall

- OD Storefront with display area (SF of storefront)
- OB Storefront without display area (SF of storefront)

Storefront-Interior Mall

- OG Interior mall fronts, includes closures (SF of storefront)

STOREFRONT (7)

STOREFRONT DRAWINGS

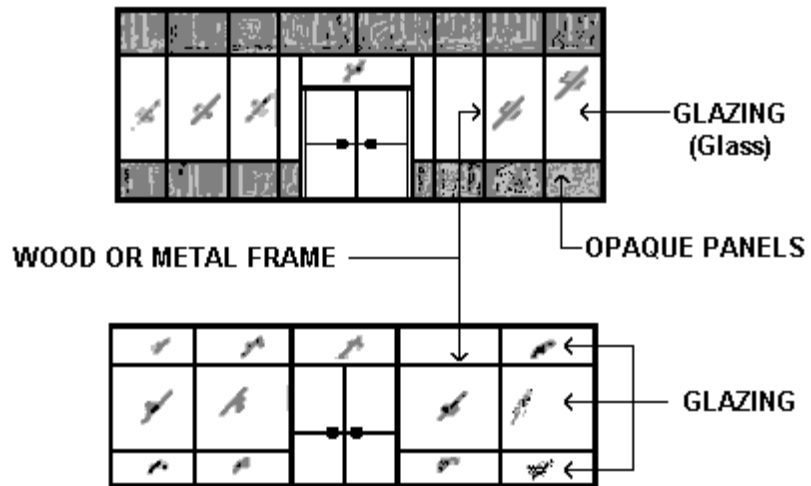
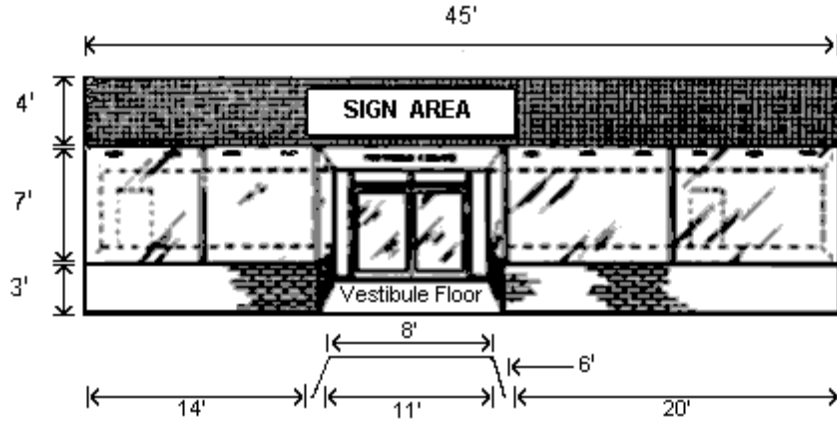

WALL ORNAMENTATION (8)

These components refer to that portion of the exterior wall surface having a different type of finish than the majority of the building, and also enhance the architectural attractiveness. The wall ornamentation components should be used with the load-bearing wall components from component [type 6 \(Exterior Wall\)](#).

MBX	Aluminum or vinyl siding on masonry (ADD; SFW)
PA	Brick face, split (ADD; SF ornamented area)
PC	Brick, face (ADD; SF ornamented area)
PD	Brick, select common (ADD; SF ornamented area)
PEA	Brick, simulated veneer (ADD; SF ornamented area)
PE	Brick, used (ADD; SF ornamented area)
PY	Cedar on masonry (ADD; SF ornamented area)
PG	Concrete block, imitation flagstone (ADD; SF ornamented area)
PI	Concrete block, ornamental face (ADD; SF ornamented area)
PH	Concrete block, screen (ADD; ornamented area)
PFB	Glass block, colored (ADD; ornamented area)
PFA	Glass block, white (ADD; SF ornamented area)
PJ	Granite (ADD; SF ornamented area)
PK	Limestone (ADD; SF ornamented area)
PL	Marble (ADD; SF ornamented area)
PM	Metal screen (ADD; SF ornamented area)
PZ	Redwood on masonry (ADD; SF ornamented area)
PR	Slate (ADD; SF ornamented area)
PO	Stone veneer, local (ADD; SF ornamented area)
PP	Stone veneer, rubble (ADD; SF ornamented area)
PNA	Stone, simulated (ADD; SF ornamented area)
PS	Stucco on masonry (ADD; SF ornamented area)
PT	Terra cotta (ADD; SF ornamented area)
PX	Textured plywood (ADD; SF ornamented area)
PU	Tile, ceramic (ADD; SF ornamented area)
PV	Tile, mosaic (ADD; SF ornamented area)
PW	Vitrolite (ADD; SF ornamented area)

ROOF STRUCTURE (9)

The roof structure costs include [joists](#), [rafters](#), [purlins](#), [sheathing](#), [decking](#), and any necessary [bracing](#) or [ties](#). Cost variations are influenced by the design, size, and spacing of structural members, and the thickness and quality of the sheathing.

A slope factor, selected from below, should also be listed with the roof structure component. This factor is listed in the miscellaneous column.

SLOPE	SLOPE FACTOR	PERCENTAGE ADJUSTMENT
Flat	1	100%
3:12	2	103%
4:12	3	106%
5:12	4	108%
6:12	5	112%
8:12	6	120%
12:12	7	142%
15:12	8	160%
18:12	9	180%

The following formula, including definitions, is a method to solve for the slope ratio.

Formula to Solve for Slope

$$\text{RISE (vertical unit)} \div \text{RUN (horizontal unit)} \times 12 = \text{SLOPE} : 12$$

Example:

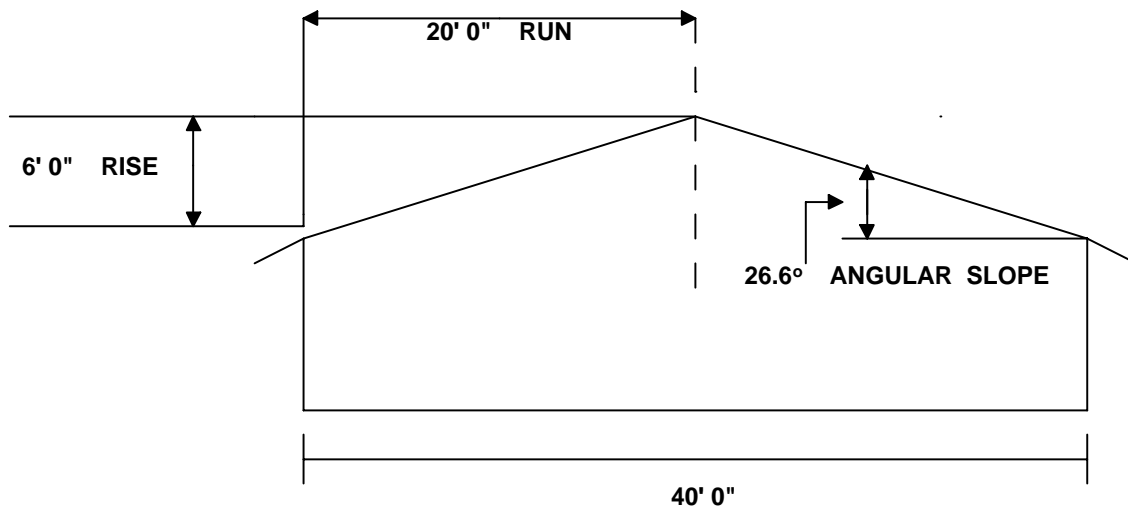

$$6 \text{ (Rise)} \div 20 \text{ (Run)} \times 12 = 0.3 \times 12 = 3.6$$

Therefore, the slope is: 3.6 : 12 Round 3.6 to 4 for slope factor.

ROOF STRUCTURE (9)

SLOPE DEFINITIONS

SLOPE FACTOR: Factor equivalency for the slope ratio.

SLOPE RATIO: Rise (vertical) to Run (horizontal) relationship; e.g., 4:12, 4 units of rise to 12 units of run. Units can be in inches, feet, meters, etc.

SLOPE DIAGRAM: Usually found on architect or engineer plans to show slope; e.g.,

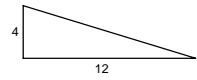

ANGULAR SLOPE: Angle equivalence for the slope ratio; e.g., 6:12 = 26.6°.

FACTOR	DIAGRAM	RATIO	ANGULAR	FACTOR	DIAGRAM	RATIO	ANGULAR
1		FLAT	0°	2		3:12	14°
3		4:12	18.4°	4		5:12	22.6°
5		6:12	26.6°	6		8:12	33.7°
7		12:12	45.0°	8		15:12	51.3°
9		18:12	56.3°				

ROOF STRUCTURE (9)

ALTERNATE ROOF STYLES—Alternate roof styles are identified by a suffix of **M** for [monitor](#) or **S** for [sawtooth](#).

Monitor Design (M). Such roofs have a raised section, normally along a ridge. The sides of this section typically have windows, louvers, or other types of vent openings.

Sawtooth Design (S). These roofs have several peaked roof surfaces, with a cross-section similar to the teeth of a saw. The steeper sides of the roof normally consist of windows, louvers, or other types of vent openings.

For a monitor or sawtooth design, the **M** (monitor) or **S** (sawtooth) may be appended to the following component codes. For example, if a wood joist, wood deck roof structure ([QAA](#)) has a monitor roof design, the code would be listed as QAAM.

QS	Open steel system for corrugated metal (SF)
QT	Open wood system for corrugated metal (SF)
QL	Steel joists, composition deck (SF)
QK	Steel joists, steel deck (SF)
QM	Steel joists, wood deck (SF)
QCA	Tongue and groove, exposed rafters (SF)
QO	Wood joists, composition deck (SF)
QAA	Wood joists, wood deck (SF)

The following codes **cannot** be modified for monitor or sawtooth design.

QXA	Architectural space frame (SF)
QA	Concrete joists, slab (SF)
QDA	Concrete joists, wood sheathing (SF) Class C, D, and S
QAE	Concrete plank on bearing wall (SF)
QD	Concrete slab (SF)
QE	Concrete, thin shell (SF)
QF	Lamella (SF)
QSA	Open steel system, light purlin support only (SF)
QTA	Open wood system, light purlin support only (SF)
QC	Precast joists and deck (SF)
QG	Steel joists, concrete slab (SF)
QH	Steel joists, gypsum (SF)
QI	Steel joists, precast plank (SF)
QJ	Steel joists, steel deck, gypsum (SF)
QAF	Wood joists, prefabricated panels (SF)
QRSW	Wood roof sheathing (SF)

Canopies—Cantilevered

QYC	Canopy, wood frame (SF canopy area)
QZC	Canopy, metal frame (SF canopy area)

ROOF STRUCTURE (9)

Canopies—Posts and Beams / Roof Structure

QZD	Canopy, mansard, metal frame (SF canopy)
QZE	Canopy, mansard, metal frame, electrical (SF canopy)
QYD	Canopy, mansard, wood frame (SF canopy)
QYE	Canopy, mansard, wood frame, electrical (SF canopy)

False Mansard Fascia

These components are for canopies over the entrances of commercial structures. False mansard framing is not a part of the roof system. These costs do not include the roof cover.

QAC	False mansard fascia, metal frame/wood sheathing (SF fascia)
QAD	False mansard fascia, wood frame/wood sheathing (SF fascia)

Marquees

A marquee is the rooflike structure over the entrance to a building. It is usually cantilevered from the building. These are generally large, heavy structures typically found on movie theaters and hotels.

QZ	Marquee, steel frame (SF of marquee area)
QY	Marquee, wood frame (SF of marquee area)

Self-Serve Car Wash Roofs

QWA	Steel (SF)
QWB	Wood (SF)

Trusses and Girders—(Apply to area supported)

QW	Glue laminated girders (SF)
QAB	Long span girders (SF)
QU	Steel trusses (SF)
QV	Timber trusses (SF)

CAUTION—The above components for trusses and girders are generally not used with a full frame that includes horizontal members.

ROOF COVER (10)

The cost of the roof cover is exclusive of the roof structure. Costs include any necessary roof flashing, gravel stops, gutters, etc. As with the roof structure, the roof cover components must be accompanied by a slope factor. Refer to component [type 9 \(Roof Structure\)](#) for the method to solve for slope ratio.

RC	Asbestos shingle (SF)
RD	Built-up composition (SF)
RR	Clay tile (SF)
RF	Composition shingle (SF)
RE	Composition, roll (SF)
RG	Concrete tile (SF)
RH	Copper (SF)
RJC	Elastomeric, fluid coat (SF)
RJB	Elastomeric, reinforced sheet (SF)
RJA	Elastomeric, single ply (SF)
RAA	Fiberglass sheets (SF)
QBA	Metal atrium frame and glazing (SF)
RW	Metal sandwich panel (SF)
RX	Metal sandwich panel, cold storage (SF)
RBA	Metal shingles (SF)
RZ	Metal, formed seams (SF)
RY	Metal, preformed sheets (SF)
RV	Plastic tile (SF)
RO	Slate (SF)
RQ	Terne (SF)
RS	Transite (SF)
RTA	Wood fiber shingles (SF)
RM	Wood shakes (SF)
RN	Wood shakes, fire-resistant (SF)
RT	Wood shingles (SF)

ADD—Use in addition to any component selected above:

RU	Insulation (ADD; SF)
RBB	Interior metal liner (ADD; SF)
RBC	Porcelain enamel finish (ADD; SF)

FLOOR STRUCTURE (11)

The components listed below include floor systems used throughout the building. These floor systems maintain the structural strength needed to support both the **live** and **dead** load requirements of the model selected.

EA	Asphalt on ground (SF)
EB	Concrete on ground (SF)
EC	Concrete, elevated slab (SF)
ED	Concrete, lift slab (SF)
EE	Concrete, pan (SF)
EV	Concrete, plank on bearing wall (SF)
EF	Concrete, precast joist, joist and slab (SF)
EAC	Concrete, precast joist, wood sheathing (SF)
EI	Steel joists, cellular deck and concrete (SF)
EJ	Steel joists, concrete slab (SF)
EH	Steel joists, corrugated deck and concrete (SF)
EAD	Steel joists, open metal grating (SF)
EK	Steel joists, precast plank (SF)
EL	Steel joists, wood sheathing (SF)
EM	Wood joists and sheathing (SF)
EN	Wood joists, bridging only (SF)

ADD—Use in addition to any component selected above:

EW	Foamed concrete subfloor (ADD; SF)
EO	Insulation (ADD; SF) 1"–6"
EAE	Super flat slab (ADD; SF)
EP	Vapor barrier (waterproofing) (ADD; SF)
EU	Sheathing (ADD; SF) 1"–6"
ESDM	Stadium seating floor structure (ADD; SFF)

Farm Building Floors

EAA	Compacted earth (SF) Class C, D, and S
EAB	Gravel (SF) Class C, D, and S
EZD	Manure gutter (SF)
EZA	Slotted floor, concrete (SF) Class C, D, and S
EZB	Slotted floor, metal (SF) Class C, D, and S
EZC	Slotted floor, wood (SF) Class C, D, and S

Greenhouse Floors

EGA	Asphalt walk (SF walk area)
EGC	Concrete walk (SF walk area)
EGB	Gravel walk (SF walk area)

Self-Serve Car Wash Floors

EWA	Asphalt (SF)
EWB	Concrete (SF)

Service Station Floors

EX	Concrete slab (SF)
EY	Wood floor structure (SF)

FLOOR COVER (12)

Floor cover components include finish material applied to the floor structure. These components are exclusive of the floor structure itself.

FA	Asphalt tile (SF)
FB	Brick, common in mortar (SF)
FD	Brick pavers in concrete (SF)
FC	Brick, acidproof (SF)
FE	Carpet and pad (SF)
FG	Computer floor on stanchions (SF)
FF	Concrete color (SF)
FH	Cork (SF)
FI	Diatomaceous earth (SF)
FL	Flagstone (SF)
FLAM	Melamine laminated flooring
FN	Hardener and sealer on concrete (SF)
FO	Hardwood (SF)
FQ	Hardwood gym floor (SF)
FP	Linoleum (SF)
FR	Marble (SF) May be substituted for granite.
FAG	Metal grating (SF)
FUA	Rubber fabric tile (SF)
FU	Rubber tile (SF)
FJ	Seamless plastic, thin coat (SF)
FK	Seamless plastic, troweled (SF)
FV	Slate (SF)
FW	Softwood (SF)
FOA	Synthetic sports surface (SF)
FX	Terrazzo (SF)
FY	Tile, ceramic (SF)
FZ	Tile, quarry (SF)
FAH	Vinyl composition tile (SF)
FAB	Vinyl sheet (SF)
FAC	Vinyl tile (SF)
FAD	Wood block, industrial (SF)
FAF	Wood over concrete, hardwood (SF)
FS	Wood over concrete, parquet (SF)
FAE	Wood over concrete, softwood (SF)

ADD—Use with FJ or FK only:

FTA	Colored chips (ADD; SF)
-----	-------------------------

INTERIOR CONSTRUCTION (13)

The two methods for determining interior construction costs are:

1. The **square foot of floor area components** are based on a cost for each square foot of floor area. Their costs include partitions, doors, stairways, closets, cabinet work, shelves, rest room partitions, and miscellany (mirrors, towel and soap dispensers, etc.) and other interior finish items typical for the occupancy and quality of the model.
2. The **alternate components** are based on a cost for each square foot of partitioned wall area and accounts only for the basic wall, the finish on that wall, and **fenestration**. If this method is used, consideration must also be given to components that are not included with the basic wall partitions, e.g., cabinets, stairs, toilet partitions, etc.

NOTE—Components HA and HB should not be used with components contained in the alternate method except where noted.

Square Foot of Floor Area Components

HA	Interior construction, framed, wood or metal studs (SFF)
HANC	Interior construction, framed, wood or metal studs, no coolers (SFF) Restrictions: Models 112x , 113x , 119x , 120x , 201x , 202x , 203x , 204x and 205x only
HB	Interior construction, masonry (SFF)
HSFC	Built-in Coolers; Used to add the cost of built-in coolers when using the square foot component with the following models: 112 , 113x , 119x , 120x , 201x , 202x , 203x , 204x 205x only

Alternate Components

Interior Partitions

HE	Accordion (SFW partition)
HF	Brick (SFW partition)
HG	Clay tile and plaster (SFW partition)
HV	Concrete (SFW partition)
HH	Concrete block (SFW partition)
HI	Gypsum block (SFW partition)
HJ	Gypsum block and plaster (SFW partition)
HL	Metal (SFW partition)
HM	Metal and glass (SFW partition)
HN	Steel channels and gypsum board (SFW partition)
HO	Steel studs and gypsum board (SFW partition)
HP	Steel studs and plaster (SFW partition)
HR	Wood frame, drywall finish (SFW partition)
HS	Wood frame, plaster finish (SFW partition)
HT	Wood frame, wood finish (SFW partition)

Special Wall Finish

These components can be used in addition to any other interior component (including HA and HB).

HZG	Granite (ADD; SFW partition)
HZH	Limestone (ADD; SFW partition)
HZI	Local stone (ADD; SFW partition)
HZJ	Marble (ADD; SFW partition)
HU	Tile (ADD; SFW partition)

INTERIOR CONSTRUCTION (13)

Residential Cabinets and Built-ins

HWA	Base cabinet (LF)
HWC	Broom closet (LF)
HWI	Built-in desk (LF)
HWY	Garage storage (SF area)
HWX	Garage workbench (LF)
HWE	Linen cabinet (LF)
HWH	Open shelves (LF)
HWF	Pullman cabinet (LF)
HWB	Wall cabinet (LF)
HWG	Wardrobe (LF)
HWD	Water heater cabinet (LF)

Residential Sinks and Countertops

HWK	Countertop, laminated plastic (LF)
HWL	Countertop, stainless steel (LF)
HWJ	Countertop, tile (LF)
HWP	Pullman top, cultured marble (LF)
HWN	Pullman top, laminated plastic (LF)
HWO	Pullman top, marble (LF)
HWM	Pullman top, tile (LF)

Residential Bathrooms

HWT	Prefabricated stall shower (EA)
HWU	Prefabricated tub-shower (EA)
HWW	Shower door (EA)
HWR	Shower tile, floor and base only (EA)
HWS	Shower tile, floor and walls only (EA)
HWV	Tub enclosure (EA)
HWQ	Tub tile (EA)

Saunas

SPRA	Sauna bath (SF bath)
------	----------------------

Commercial Rest Room Partitions

HKA	Laminated plastic toilet partition (EA)
HKB	Marble toilet partitions (EA)
HKC	Metal toilet partitions (EA)
HKD	Wood toilet partitions (EA)

Cold Storage Facilities

HZ	Cold storage doors (ADD; SF door area) Range 2–12" thick
HZW	Cooler door, walk-in box (EA)
HX	Insulation, fiberglass batts (ADD; SF area) Range 2–20" thick
HY	Insulation, rigid (ADD; SF area) Range 2–20" thick

The above cold storage interior components may be used in addition to HA or HB.

INTERIOR CONSTRUCTION (13)

Commercial Mezzanines and Interior Balconies

See component type 23 (Mezzanines and Interior Balconies) for interior mezzanines and interior balcony components.

Basement Interior Construction

NO	Basement, finished (SF basement area)
NP	Basement, partially finished (SF basement area)
NQ	Basement, unfinished (SF basement area)

Farm Buildings—Interior Construction

HTE	Concrete curb (LF)
LOF	Lofts (SF area) Use with farm buildings only. May be used with HA and HB.
HTA	Unfinished boards one side (SFW partition)
HTB	Unfinished boards two sides (SFW partition)
HTD	Wood studs, spaced boards one side (SFW partition)

ADD—Use in addition to any component selected above:

HTC	Wood boards over 1 inch (ADD; SFW partition)
-----	--

Quonset Buildings—Interior Construction

HAZ	Interior construction, framed, commercial (SF)
HAY	Interior construction, framed, industrial (SF)
HAX	Interior construction, framed, rural (SF)
HBZ	Interior construction, masonry, commercial (SF)
HBY	Interior construction, masonry, industrial (SF)
HBX	Interior construction, masonry, rural (SF)

INTERIOR CONSTRUCTION (13)**SHOPPING CENTER TENANT MIXES**

It is impractical to track and adjust for the different interiors in shopping centers. In some locations it could change monthly as businesses come and go. The table below shows the typical mix, excluding major anchors, found in these types of improvements.

Model Classification	Neighborhood Center or Strip Store	Community Center	Regional Center
Retail	25%	44%	47%
Discount	15%	17%	19%
Food	17%	9%	8%
Food Service	13%	9%	8%
Commercial	11%	7%	4%
Personal Services	14%	7%	3%
Recreational	3%	5%	4%
Miscellaneous	2%	2%	7%

SHOPPING CENTER CLASSIFICATION KEY

Retail—All general retail and specialty stores.

Discount—Discount, including large drug, furniture, hardware, garden, etc.

Food—Market, convenience/specialty foods, delicatessen, bakery, florist, etc.

Food Service—Restaurant, lounge, cafeteria, fast food outlets, etc.

Commercial—Office, financial, medical, post office, etc.

Personal Services—Laundry, barber, beauty, health club, repair shop, etc.

Recreational—Theater, bowling, skating, clubhouse, day care, etc.

Miscellaneous—Storage and service center areas (office, security, etc.) including nonpublic access ways and rest rooms.

INTERIOR CONSTRUCTION (13)

MIXED USE INTERIOR PROCEDURE

Interior component costs reflect the typical interior construction according to the model selected. These costs are based on normal use of that model. In some situations, it may be necessary to adjust the components to another use. This can be done by overriding the model number on the base factor line with the appropriate model number at the component level.

The components that can be adjusted in this manner are: [Floor Covering \(12\)](#), Interior Construction (13), [Ceiling \(14\)](#), [Plumbing \(15\)](#), [Heating and Cooling \(17\)](#), and [Electrical \(18\)](#). This allows for changing all components involving the interior of the improvement.

EXAMPLE: A business office building (151-3) has a bank interior in 20% of the floor area. Thus:

DESCRIPTION	CODE	UNITS-%	RANK	MODEL
Interior Construction, framed (SF)	HA	80		151-3
Interior Construction, framed (SF)	HA	20		161-3

CEILING (14)

Components include the cost of an exposed ceiling finish, but do not include the cost of the supporting structure. Supporting structure costs are usually included in the cost of the floor or roof assembly.

GGA	Acoustical, metal panels (SF) See Note 1
GGB	Acoustical, mineral fiber (SF) See Note 1
GGC	Acoustical, organic fiber (SF) See Note 1
GHA	Fiber sports court panel (SF) See Note 1
GY	Fiberboard sheets (SF)
GI	Finish only, on exposed roof structure (SF)
GH	Gypsum board, taped and painted (SF)
GZ	Gypsum board, spray-on texture (SF)
GGD	Metal ceiling, embossed (SF)
GAD	Mirror faced panels (SF) See Note 1
GJ	Plaster on lath, acoustical (SF)
GK	Plaster on lath, spray-on (SF)
GL	Plaster on lath, standard (SF)
GM	Plaster on masonry, acoustical (SF)
GN	Plaster on masonry, spray-on (SF)
GO	Plaster on masonry, standard (SF)
GR	Plastic panels (SF) See Note 1
GPA	Plywood (SF)
GS	Printed hardboard (SF)
GT	Wood boards (SF)

Special Decorative Ceilings

GTA	Decorative ceiling, carved wood (SF)
GTD	Decorative ceiling, extensive decorating (SF)
GTC	Decorative ceiling, moderate decorating (SF)
GTB	Decorative ceiling, plain decorating (SF)

NOTE 1—These costs include the panels or tiles only. The method of attachment, i.e., suspension or furring, must be selected from the ADD components.

ADD—Use in addition to any component selected above:

GW	Ceiling insulation (ADD; SF)
GX	Ceiling joists (ADD; SF)
GAA	Metal furring (ADD; SF)
GAB	Metal lath (ADD; SF)
GV	Suspended ceiling (ADD; SF)
GU	Wood furring (ADD; SF)

PLUMBING (15)

Costs are for the complete plumbing installation. Included are rough and finished, and supply and waste lines to the property line of a typical building.

There are 3 methods to develop plumbing costs: (1) **square foot of floor area component**, (2) **the number of fixtures component** or (3) a **number of different types of specific fixtures components(residential only)**.

Square Foot of Floor Area Component

The plumbing costs included with the square foot of floor area component are based on plumbing fixtures, pipe runs, and drains typical of a structure of that model and quality. This method should be used for the majority of buildings.

CAUTION—Do not use IA in conjunction with any components from the other methods.

IA Plumbing (SF)

Alternate Components

Alternate components should only be used for those buildings where a standard square foot of floor component cannot be utilized.

Commercial and Industrial Fixtures

UC Drinking fountain (EA)
IZ Plumbing drain (EA)
UZ Refrigerated water cooler (EA)
IB Plumbing fixtures (Number of)

Commercial Greenhouse Plumbing

IGB Automatic water system controls (EA)
IGA Plastic water system (SF area covered)

Quonset Building Plumbing

IAZ Plumbing, commercial (SF)
IAY Plumbing, industrial (SF)
IAX Plumbing, rural (SF)

PLUMBING (15)

Residential Fixtures

Costs for the following components reflect residential quality and the short pipe and drain runs typical of residential improvements. **Do not** use these codes in a commercial or institutional building.

IC	Bathtub (EA)
IN	Bidet (EA)
IM	Hydrotub (EA)
IE	Kitchen sink (EA)
IF	Laundry tray (EA)
IG	Lavatory (EA)
IL	Rough-in (EA) Includes outside faucets, washer connections, etc.
ID	Shower over tub (ADD; EA)
IJ	Stall shower (EA)
IH	Toilet (EA)
IK	Water heater (EA)
ISW	Solar hot water heater (Number of Units)
IW	Wet bar (EA)

FIRE PROTECTION (16)

Components include costs for the complete system, associated supply lines, and electrical connections. Tanks, towers, or high-pressure pumps are not included. Both wet and dry systems are included. The wet system maintains a supply of water in the lines while the dry system has air in the lines. The less expensive of the two is the wet system.

Automatic Sprinkler and Fire Control Systems

JFH	Fire hydrant (EA)
JA	Sprinklers (SF)
JAC	Sprinklers, double heads (ADD; SF)
JAB	Sprinkler, extra hazard (ADD; SF)
JBQ	Inside standpipe (per hose outlet)
JBP	Outside standpipe (per hose outlet)
JBR	Siamese connection (EA)

Fire Detection and Alarm Systems

JBD	Fire alarm control panel, 1 zone (EA)
JBE	Additional zones (EA)
JBN	Battery standby system (EA)
JBM	Date, time, location printer (EA)
JBK	Emergency telephone (Per 5 jacks)
JBH	Fire control room panel (Per 75 zones)
JC	Heat and rate of rise detector (EA)
JBJ	Panel speaker (EA)
JBF	Pull station (EA)
JBG	Smoke detector, hardwired in system (EA)
JBL	Water flow detector (EA)

Residential Smoke Detectors

UEA	Smoke detectors, battery-operated (EA)
-----	--

HEATING, COOLING, AND VENTILATION SYSTEMS (17)

Components include the basic heating and cooling unit for the particular system and any [boilers](#), pumps, oil or gas burners, [cooling towers](#), piping, ducts, registers, operating motors, and fans.

Unless otherwise noted in the descriptions, all costs are based on gas as a source of fuel. When other fuels or firing methods are encountered, append one of the following to the appropriate heating code:

B	Coal with stoker
C	Coal, hand-fired
O	Oil-fired

For example, the component code for a forced air heating system is KC. If that system were oil-fired, the component code would become KCO.

Heating Only

KA	Electric (SF)
KB	Electric wall heaters (SF)
KD	Floor furnace (SF) Alternate fuel—all.
KC	Forced air (SF) Alternate fuel—all.
KF	Gravity furnace (SF) Alternate fuel—all.
KH	Hot water (SF) Alternate fuel—all.
KZ	Radiant gas (SF)
KI	Radiant hot water (SF) Alternate fuel—all.
KAZ	Solar heating, air system (SF)
KAY	Solar heating, liquid system (SF)
KJ	Space heat (SF) Alternate fuel—O.
KK	Space heat, steam (SF) Alternate fuel—O.
KX	Space heat, steam without boiler (SF)
KL	Steam with boiler (SF) Alternate fuel—all.
KM	Steam without boiler (SF)
KU	Wall furnace (SF) Alternate fuel—all.

Cooling Only

KR	Evaporative cooling (SF)
KRA	Evaporative cooling, without ducting (SF)
KS	Refrigerated cooling (SF)
UAM	Window air conditioner, wall installed (EA)
UAN	Window evaporative cooler, wall installed (EA)

Heating and Cooling

For heating and cooling in enclosed malls, see component type 22 (Shopping Center Malls).

KYA	Complete HVAC (heating, cooling, and ventilation) (SF) Restricted to models 201-x, 202-x (Restaurants), 213-x (Hospitals), and 216-x (Surgical Centers).
KQ	Heat pump (SF)
KN	Hot and chilled water (SF) Alternate fuel—all.
KBM	Individual thru-wall heat pump (SF)
KP	Package heating and cooling (SF) Alternate fuel—all.
KO	Warm and cooled air (SF) Alternate fuel—all.
UBQ	Window heat pump, wall installed (EA)

NOTE—For evaporative cooling and forced air system combination, use KP.

HEATING, COOLING, AND VENTILATION SYSTEMS (17)

Mobile Homes Only

- KSM Air conditioning, without duct work (SF)
- KQM Heat pump, without duct work (SF)

Ventilation

- KT Ventilation (SF)

Greenhouse Heating and Cooling

- KGD Exhaust fan (EA)
- KGE Gas furnace (SF)
- KGF Hot water heating (SF)
- KGG Humidifier (EA)
- KGK Humidity pad, water drip (SF pad area)
- KGJ Space heat (SF) Use KGA to add for duct distribution.
- KGL Steam heat (SF)
- KGM Vent, automatic (EA)

ADD—Use in addition to any component selected above:

- KGA Duct, fan jet (ADD; SF)

Clean Rooms

- KYC Clean room, class 100,000 to 10,000 (SF Floor)
- KYD Clean room, class 1,000 to 100 (SF Floor)
- KYE Clean room, class 100 to 10 (SF Floor)

ELECTRICAL (18)

The electrical components include all costs associated with the electrical system, including the building's general distribution service, wiring, outlets, and fixtures. The quality of the fixtures, number of outlets, and the type of wiring for the model may influence the cost rank. Costs do not include the power distribution, wiring, fixtures, or equipment for industrial applications.

Interior decorative lighting that is incidental to the building is included in LA. Exterior decorative lighting is not included.

LA	Electrical, finished (SF)
LB	Electrical, unfinished (SF)

Service Station

LC	Basic power service (EA) Includes two circuits.
LD	Additional circuits (EA)

Quonset Building

LAX	Electrical, finished, rural (SF)
LAY	Electrical, finished, industrial (SF)
LAZ	Electrical, finished, commercial (SF)
LBX	Electrical, unfinished, rural (SF)
LBY	Electrical, unfinished, industrial (SF)
LBZ	Electrical, unfinished, commercial (SF)

Basement Electrical and Lighting

NX	Electrical, finished (SF basement area)
NY	Electrical, partially finished (SF basement area)
NZ	Electrical, unfinished (SF basement area)

Emergency Lighting

JBA	Auxiliary light packs, single head (EA)
-----	---

ELEVATORS (19)

Components include the cost of the elevator cars, tracks, cables, motors and controllers, and lobby hardware. The cost for the shafts is also included. There are two methods for developing elevator costs: the **square foot of floor area component** and the **car and stop components**.

NOTE—**Do not** deduct the square feet of elevator from the total square feet of the building.

Square Foot of Floor Area Component

This method is based on the typical needs of the model and quality selected.

TA Elevator (SF)

Car and Stop Components

This method refers to the number of cars in operation and the number of stops each car makes. The [cost rank selection tables](#) should be utilized to select the proper cost rank for these components. Data required are the speed and capacity of each car.

TR	Bypassed floors (For all cars, total number of floors with no stops)
TF3	Freight elevator, electric, manual doors (Cars, stops–rank table)
TF4	Freight elevator, electric, power doors (Cars, stops–rank table)
TF1	Freight elevator, hydraulic, manual doors (Cars, stops–rank table)
TF2	Freight elevator, hydraulic, power doors (Cars, stops–rank table)
TU	Multistory, fully automatic (Cars, stops–rank table)
TT	Multistory, passenger-operated, electric (Cars, stops–rank table)
TS	Multistory, passenger-operated, hydraulic (Cars, stops–rank table)
TK	Sidewalk elevator (Cars, stops–rank table)

Miscellaneous Elevators

TJ	Dumbwaiter, electric (Cars, stops)
TM	Dumbwaiter, hand-operated (Cars, stops)
TL	Escalator (Number of stairways–ranks table)
TP	Inclinor (EA; per 14– to 17–foot run)
TV	Moving walks (LF–Rank table)
TH	Personal lift (Cars, stops)
TQ	Wheelchair lift (EA)

Residential Elevators

Restricted to single family residential models (010–x through 016–x) and condominium or townhouse models (070–x, 071–x and 072–x).

TO	3–story (EA)
TN	2–story (EA)

ELEVATORS (19)**RANK SELECTION TABLES****TS Multistory, Passenger-Operated, Hydraulic**

SPEED	CAPACITY					
	1,500	2,000	2,500	3,000	4,000	5,000
50	1.0	1.4	1.8	2.1	2.5	2.9
75	1.4	1.9	2.2	2.4	2.9	3.2
100	1.8	2.2	2.5	2.8	3.1	3.4
125	2.0	2.4	2.7	3.0	3.3	3.6
150	2.3	2.6	2.9	3.1	3.4	3.7
200	2.5	2.9	3.2	3.4	3.7	3.9

TT Multistory, Passenger-Operated, Electric

SPEED	CAPACITY							
	AC Rheostatic		Variable Voltage					
	1,200	2,000	1,500	2,000	2,500	3,000	4,000	5,000
50	1.0	1.4	—	—	—	—	—	—
100	1.6	2.0	2.0	2.2	2.5	2.7	3.0	3.2
150	2.0	2.3	2.2	2.6	2.7	2.9	3.2	3.4
200	—	—	2.5	2.7	2.9	3.1	3.3	3.6
300	—	—	2.8	3.0	3.2	3.3	3.7	3.8
400	—	—	3.0	3.2	3.4	3.5	3.8	4.0

TU Multistory, Fully Automatic

SPEED	CAPACITY					
	2,000	2,500	3,000	3,500	4,000	5,000
300	1.0	1.1	1.2	1.3	1.4	1.7
400	1.2	1.3	1.4	1.5	1.7	1.9
500	1.4	1.5	1.6	1.8	1.9	2.1
600	1.6	1.7	1.9	2.0	2.1	2.3
700	1.8	2.0	2.1	2.2	2.3	2.5
800	2.0	2.2	2.3	2.4	2.5	2.7
1000	2.5	2.6	2.7	2.8	2.9	3.2
1200	2.9	3.0	3.1	3.2	3.3	3.6
1400	3.3	3.4	3.5	3.7	3.8	4.0

ELEVATORS (19)

RANK SELECTION TABLES

TV Moving Walks

LENGTH (Feet)	WIDTH (Inches)		
	36	48	54
100	3.4	3.8	4.0
300	2.5	2.9	3.2
500	2.1	2.5	2.8
750	1.7	2.2	2.5
1000	1.5	2.0	2.3
1400	1.3	1.7	2.0
1800	1.0	1.5	1.9

TL Escalators

RISE (Feet)	WIDTH (Inches)	
	32	48
10	1.0	1.8
14	1.5	2.4
18	2.0	3.0
22	2.5	3.5
25	2.9	4.0

TF1 Freight Elevator, Hydraulic, Manual Doors

TF2 Freight Elevator, Hydraulic, Power Doors

SPEED	CAPACITY							
	2,000	4,000	5,000	6,000	8,000	10,000	15,000	20,000
50	1.0	1.4	1.5	1.6	1.8	2.5	3.1	3.6
100	1.5	1.8	1.9	2.0	2.1	2.8	3.4	3.8
125	1.7	2.0	2.1	2.2	2.3	2.9	3.5	3.9
150	2.0	2.2	2.2	2.3	2.4	3.0	3.6	4.0

TF3 Freight Elevator, Electric, Manual Doors

TF4 Freight Elevator, Electric, Power Doors

SPEED	CAPACITY							
	2,000	4,000	5,000	6,000	8,000	10,000	15,000	20,000
100	1.0	1.3	1.4	1.5	1.8	2.0	—	—
200	1.5	1.8	1.9	2.1	2.4	3.0	3.8	—
300	1.9	2.3	2.5	2.6	3.0	3.6	—	—
400	2.4	2.7	3.0	3.2	3.6	4.0	—	—

SPECIAL PURPOSE BUILDINGS (20)

Special purpose buildings include:

Car Washes	Quonset Building
Commercial Greenhouse	Service Stations

Car Wash Buildings

Self-Service Car Wash

Components are for the equipment room only. Cost includes walls, doors, lighting, and plumbing. For other parts of the car wash, use the special car wash components provided in other component types: 6 (bay walls), 10 (bay roof), and 11 (bay floors).

YWA	Masonry (SF)
YWB	Steel (SF)
YWC	Wood frame with stucco (SF)

Drive-thru Car Wash

Components are for the building shell. Costs include concrete slab, floor drains, basic electrical, lighting and water service, and equipment enclosure. For other items, refer to the appropriate component types: 6 (bay walls), 10 (bay roof), and 11 (bay floors).

YWD	Masonry (SF)
YWE	Porcelainized steel (SF)
YWF	Steel (SF)
YWG	Wood frame with stucco (SF)

Automatic Car Wash

Components are for the building shell. Costs include concrete slab, floor cover, floor drains, basic electrical, lighting and water service, finished office area, locker and rest rooms, and equipment room.

YWJ	Masonry (SF)
YWK	Porcelainized steel (SF)
YWL	Steel (SF)
YWM	Wood frame with stucco (SF)

Commercial Greenhouse

The following components are for a complete commercial greenhouse. The cost includes foundation, framing, wall and roof panels, lighting and water service, ventilation openings, doors, and fasteners. Cost for other items should be added using the special greenhouse components in the following component types: [11 \(Floor Structure\)](#), [15 \(Plumbing\)](#), and [17 \(Heating and Cooling\)](#).

NOTE—Residential greenhouse components are found in component type [36 \(Yard Improvements\)](#). **Do not** use these components.

SPECIAL PURPOSE BUILDINGS (20)

Straight Walls

YGA	Curtain (SF)
YGB	Fiberglass (SF)
YGC	Glass (SF)
YGD	Plastic, double (SF)
YGE	Plastic, single (SF)
YGF	Structural polycarbonate (SF)

Bow Walls

YGJ	Fiberglass (SF)
YGK	Plastic, double (SF)
YGL	Plastic, single (SF)
YGM	Structural polycarbonate (SF)

Modified Bow Walls

YGR	Fiberglass (SF)
YGS	Plastic, double (SF)
YGT	Plastic, single (SF)
YGU	Structural polycarbonate (SF)

Quonset Buildings

Components are for prefabricated metal buildings with a semicircular roof of corrugated metal that curves down to the ground forming the exterior walls. The cost includes installation, concrete footings, and shell with minimum fenestration. For electrical, use the special Quonset building components in component type 18 (Electrical).

NOTE—A cost rank from the [rank table](#) provided must be entered for each component.

YQA	Commercial (SF)
YQB	Industrial (SF)
YQC	Agricultural (SF)

Service Stations

The following components are for a complete vehicle service station. The cost includes foundation, floor, framing, exterior wall, fenestration, garage doors, roof, electrical, and plumbing. Other items such as heating and cooling and yard improvements should be added.

YC	Masonry (SF)
YA	Steel Frame (SF)
YB	Wood Frame (SF)

SPECIAL PURPOSE BUILDINGS (20)**RANK SELECTION TABLE****QUONSET BUILDINGS**

LENGTH (Feet)	WIDTH (Feet)			
	30	40	60	70
30	4.0	—	—	—
36	3.6	—	—	—
48	3.1	3.6	—	—
60	2.8	3.3	3.7	—
72	2.4	2.9	3.4	3.5
84	2.3	2.7	3.1	3.3
96	1.9	2.4	2.9	3.0
108	1.7	2.3	2.7	2.9
120	1.5	2.1	2.5	2.7
160	1.0	1.7	2.0	2.1
200	—	1.2	1.6	1.7
240	—	1.0	1.2	1.5

MISCELLANEOUS BUILT-IN CONSTRUCTION (21)

The following components represent built-in items frequently found in structures. Additional items may be found in [component types 29 \(Other\)](#) and [30 \(Additional Components\)](#).

NOTE—Components with "SF area" have costs that may vary greatly. These should be used with caution.

Bank Components (Also component type 30)

UAD	Money Bank Vault (SF vault area)
UAG	Record Storage Bank Vault (SF vault area)

Skylight (Residential Only)

The component for skylights is restricted to residential use only.

NOTE—Skylights found in commercial and industrial buildings are relatively small in size and are included with the roof cover costs. Costs need not be adjusted. For skylights with extensive patterning or design, use code [QBA \(metal atrium frame and glazing\)](#) in conjunction with [QXA \(architectural space frame\)](#).

UEB	Skylight (SF framed area)
UETS	Tubular Skylight (EA)

Residential Built-ins

APK	Kitchen, single unit (EA)
APP	Appliance allowance (Number of kitchens) May be used with apartments.
APPD	Clothes dryer (EA)
APPW	Clothes washer (EA)
APPC	Clothes washer and dryer combination (EA)
UAE	Bathroom heater (EA)
UAF	Dishwasher (EA)
UAO	Exhaust fan (EA)
UD	Exhaust fan and hood (EA)
UAOE	Vent, appliance (EA)
UE	Garbage disposal (EA)
UO	Gas incinerator (EA)
UV	Microwave oven (EA)
UF	Mixer-blender (EA)
UL	Oven (EA)
ULA	Oven, microwave combination (EA)
UG	Radio-intercom (EA)
UH	Radio-intercom, satellite (EA)
UK	Range top (SF)
UKA	Range top, induction (EA)
UJA	Range and microwave combination (EA)
UJ	Range and oven (EA)
UM	Refrigerator (EA)
UN	TV outlet (EA)
UR	Trash compactor, central unit (EA)
US	Trash compactor, single unit (EA)
UP	Vacuum cleaner system, includes 3 outlets (EA)

MISCELLANEOUS BUILT-IN CONSTRUCTION (21)

ADD—Use in addition to **UP** only:

UT Vacuum cleaner system, extra outlet (ADD; EA)

Chimneys

These components are not for use with residential fireplaces or heating components. Use them for additional chimneys built to service added heating appliances.

JBZ Galvanized chimney, 10-inch diameter (LF)
JBX Galvanized chimney, 6-inch diameter (LF)
JBY Galvanized chimney, 8-inch diameter (LF)
JBV Masonry chimney, 10-inch round or square flue (LF)
JBW Masonry chimney, two 8-inch round or square flues (LF)
JBU Masonry chimney, 8-inch round or square flue (LF)
JCA Metal stack, double wall (LF)
JCB Metal stack, triple wall (LF)

Fireplaces

VDA Fireplace, single hearth, one-story chimney (EA)
 Use VDM for additional stories; use VDP for additional openings.
VDF Prefabricated fireplace, one-story (EA)
 Use VDN for additional stories. No cost generated—identifies heat source.
VDVG Fireplace, direct-vented, gas (EA)

ADD—Use in addition to VDA or VDF as noted:

VDM Chimney flue, additional stories (ADD; each story over 1) Use with VDA.
VDP Fireplace opening (ADD; EA additional opening) Use with VDA.
VDN Prefabricated fireplace, chimney stack, additional stories (ADD; each story over 1)
 Use with VDF.

ADD—Use in addition to any component selected above:

VDG Heatilator (ADD; EA)
VDI Log lighter (ADD; EA)
VDH Raised hearth (ADD; EA)

Bleachers and Auditorium Seating

UBZ Auditorium seating (EA seat)
UBY Bleachers, permanent, steel and fiberglass (SF of projection)
UBX Bleachers, permanent, wood (SF of projection)
UBV Bleachers, telescoping (SF of projection opened)

ADD—Use in addition to UBV only:

UBW Bleachers, power operation (ADD; EA)

Stages and Theaters

UAK Speaker platform (SF of platform area)
UAH Stage and fixtures, live performance (SF stage area)
UAJ Stage and fixture, motion picture only (SF stage area)

SHOPPING CENTER MALLS (22)

Models [141-x](#), [142-x](#), [143-x](#)

Shopping centers are buildings designated as a group of commercial enterprises and developed as a unit. Complete centers are broken down into the following categories:

Principal or major tenant buildings, generally referred to as anchors or magnets, are valued using the appropriate model, e.g., [130-x \(mall anchor department store\)](#) or [132-x \(discount store\)](#).

General satellite or strip stores are valued using one of the three shopping center models, e.g., [141-x \(neighborhood shopping center\)](#).

Mall or pedestrian concourse areas are valued using the components listed below. These components are used in addition to the main buildings.

Mall Area

MLC	Covered mall (ADD; SF concourse area)
MLE	Enclosed mall (ADD; SF concourse area) Includes heating, ventilation, and air conditioning (HVAC).
MLH	Enclosed mall (ADD; SF concourse area) Does not include HVAC.
MLO	Open mall (ADD; SF concourse area)

Elevators and Escalators

MTA	Elevators (SF area served) Use only with MLE or MLH above.
---------------------	--

Heating, Cooling, and Ventilation

KYB	Complete heating, ventilation, and air conditioning (SF) Use only with MLH above.
---------------------	---

NOTE—In malls over 1 story, stairs (use exterior stairs component) and balconies must be listed as additional items. Refer to [Volume I, Appendix A](#) for more detailed listing procedures.

MEZZANINES AND INTERIOR BALCONIES (23)

Square Foot of Floor Area Components

The component costs include the complete mezzanine or interior balcony, including floor structure, floor cover, soffit, railing, and stairs.

Mezzanine

MZM	Display mezzanine (SF mezzanine area)
MZB	Office mezzanine (SF mezzanine area)
MZD	Open mezzanine (SF mezzanine area)
MZC	Storage mezzanine (SF mezzanine area)
MZH	Storage mezzanine, heavy structure (SF mezzanine area)

Stepped Interior Balconies

BCD	Balconies, auditorium interior (SF balcony area)
BCC	Balconies, church interior (SF balcony area)
BCT	Balconies, theater interior (SF balcony area)

Residential Only

HAA	Attic, finished (SF)
HAL	Loft, open (SF)

Alternate Components

The mezzanine or interior balcony is built using the components listed below. The cost does not include floor cover or soffit finish.

Floor Structure, Stepped Interior Balconies

EQ	Concrete (SF balcony area)
ER	Concrete and Steel (SF balcony area)
ES	Wood (SF balcony area)
ET	Wood and Steel (SF balcony area)

RESIDENTIAL PORCH OR PATIO (26)

Patio, Without Roof Structure and Cover

The cost for patios includes the footing, foundation, and decking.

VAC	Open concrete slab with steps (SF)
VAD	Open concrete slab without steps (SF)
VAE	Wood deck with steps (SF)
VAF	Wood deck without steps (SF)

NOTE—Size range for the above patio components is 25–2,000 SF.

Porch or Patio

Porch or patio costs include [footing](#), [foundation](#), concrete or wood floor, supporting posts and beams, roof structure and cover. Fir and pine are the lower cost ranks (1 and 2) and redwood the higher cost ranks (3 and 4).

POT	Open porch or patio with steps (SF)
POR	Open porch or patio without steps (SF)
PORE	Porch, enclosed (SF)
POTE	Porch-patio with steps, enclosed (SF)
POW	Wood deck with steps and roof (SF)
POWE	Wood deck with steps and roof, enclosed (SF)
POX	Wood deck and roof without steps (SF)
POXE	Wood deck and roof without steps, enclosed (SF)

Awning, Without Floor Structure

Costs include the supporting posts and beams, roof structure and cover.

POA	Awning, metal (SF)
POS	Awning, slatted or louvered (SF)
POD	Awning, wood, includes cover (SF)

ADD—Use in addition to any component selected for patios, porches, or awnings:

VAH	Ceiling (ADD; SF ceiling area)
-----	--------------------------------

RESIDENTIAL EXTERIOR BALCONIES (27)

Balcony costs include the supporting structure, decking, and rails. The roof and other items of finish must be selected from the appropriate component types.

Residential Exterior Balconies

VAL	Cement composition, iron rails (SF balcony area)
VAK	Cement composition, wood rails (SF balcony area)
VAJ	Wood, iron rails (SF balcony area)
VAI	Wood, wood rails (SF balcony area)

ADD—Use in addition to any component selected above:

VAM	Finished soffit (ADD; SF balcony area)
-----	--

EXTERIOR STAIRS (28)

Commercial Exterior Stairs and Fire Escapes

NDA	Concrete stairway (EA riser)
NEA	Concrete and steel stairway (EA riser)
NCA	Fire escape (EA) Includes two-story fire escape and ladder to roof. Use NCB for additional flights.
NCB	Fire escape, additional flights (EA flight) Use with NCA.
NAA	Steel stairway (EA riser)
NBA	Wood stairway (EA riser)

Residential Exterior Stairs

VAQ	Cement composition, iron rails (EA flight)
VAP	Cement composition, wood rails (EA flight)
VAR	Steel, ornamental iron rails (EA flight)
VAO	Wood, iron rails (EA flight)
VAN	Wood, wood rails (EA flight)

ADD—Use in addition to any residential exterior stairs:

VAS	Finished soffit (ADD; EA flight)
-----	----------------------------------

OTHER (29)

Shipping and Loading Docks

Shipping docks are covered structures that include adequate lighting, plumbing, and some office or storage area depending on the construction quality.

Loading docks are raised and usually run the length of the building to facilitate loading and unloading. These are generally used for supermarkets, department stores, warehouses, and so forth, where the floor of the building is at ground level.

DOF	Dock-height floor (ADD; SF)
DBU	Dock bumpers, horizontal (LF)
DBV	Dock bumpers, vertical (LF)
DBW	Dock levelers, mechanical (EA)
DBX	Dock levelers, hydraulic (EA)
DBY	Dock levelers, edge of dock (EA)
DLR	Loading dock with roof (SF area)
DLW	Loading dock without roof (SF area)
DLX	Loading well, single (EA)
DLY	Loading well, single (ADD; EA) Use with DLX.
DOS	Shipping dock (SF area)

Miscellaneous Items

SPX	Ladder, aluminum (LF)
SPY	Ladder, safety cage (LF)
RCA	Railings, controlled area (LF)
SPW	Spiral stairs, aluminum (EA flight)

Solar Room

A 3-wall glass enclosed room typically attached to a commercial structure providing a suitable retail or dining area. This component may be found attached to high end residential improvements. The cost includes foundation, [glazing](#), [anodized aluminum](#) frame, openings, and installation.

SLR	Solar room (SF) Size range is 35–900 SF.
-----	--

Commercial Balconies

Balcony costs include the supporting structure, decking, and rails. Roofs and other items of finish must be selected from the appropriate component type and listed with the balcony entry.

BDA	Concrete (SF balcony area)
BDB	Steel (SF balcony area)
BDC	Wood (SF balcony area)

Bleachers

UBI	Bleachers, grandstand (SF of projection)
UBOM	Bleachers, municipal stadium (SF of projection)
UBO	Bleachers, stadium (SF of projection)

OTHER (29)**CHURCHES****Church Domes**

SSG	Small fiberglass dome (Diameter of base in feet) Up to 8 feet in diameter
SSH	Small metal dome (Diameter of base in feet) Up to 8 feet in diameter
SSI	Small stucco dome (Diameter of base in feet) Up to 8 feet in diameter
SSJ	Small wood dome (Diameter of base in feet) Up to 8 feet in diameter
SSK	Large fiberglass dome (Diameter of base in feet) Above 8 feet in diameter
SSL	Large metal dome (Diameter of base in feet) Above 8 feet in diameter
SSM	Large wood dome (Diameter of base in feet) Above 8 feet in diameter

Church Masonry Towers

STE	Tower, adobe (SFW)
STH	Tower, brick veneer (ADD; SFW)
SSQ	Tower, common brick masonry (SFW)
SST	Tower, concrete (SFW)
SSU	Tower, concrete block (SFW)
SSR	Tower, face brick (ADD; SFW)
SSX	Tower, stone masonry (SFW)
SSW	Tower, stone veneer (ADD; SFW)
STF	Tower, stucco (ADD; SFW)
STG	Tower, tile (ADD; SFW)

Church–Wood or Steel Framed Towers

STK	Tower, brick veneer (ADD; SFW)
SSV	Tower, metal (SFW)
STJ	Tower, shingle (SFW)
STL	Tower, stone veneer (ADD; SFW)
SSZ	Tower, stucco (SFW)
SSY	Tower, wood siding (SFW)

Church Towers–Miscellaneous

STN	Tower stairs (ADD; LF of height)
STM	Tower, interior facing (ADD; SFW)

Cupolas

SRB	Copper or terne cupola, 10 to 20 feet (LF of height)
SRC	Copper or terne cupola, over 20 feet (LF of height)
SRA	Copper or terne cupola, up to 10 feet (LF of height)
SRE	Fiberglass cupola, 10 to 20 feet (LF of height)
SRF	Fiberglass cupola, over 20 feet (LF of height)
SRD	Fiberglass cupola, up to 10 feet (LF of height)
SRH	Metal cupola, 10 to 20 feet (LF of height)
SRJ	Metal cupola, over 20 feet (LF of height)
SRG	Metal cupola, up to 10 feet (LF of height)
SRL	Wood cupola, 10 to 20 feet (LF of height)
SRM	Wood cupola, over 20 feet (LF of height)
SRK	Wood cupola, up to 10 feet (LF of height)

OTHER (29)**CHURCHES****Spires**

SRP	Copper or terne spire, 10 to 20 feet (LF of height)
SRQ	Copper or terne spire, over 20 feet (LF of height)
SRN	Copper or terne spire, up to 10 feet (LF of height)
SRS	Fiberglass spire, 10 to 20 feet (LF of height)
SRT	Fiberglass spire, over 20 feet (LF of height)
SRR	Fiberglass spire, up to 10 feet (LF of height)
SRV	Metal spire, 10 to 20 feet (LF of height)
SRW	Metal spire, over 20 feet (LF of height)
SRU	Metal spire, up to 10 feet (LF of height)
SRY	Wood spire, 10 to 20 feet (LF to height)
SRZ	Wood spire, over 20 feet (LF to height)
SRX	Wood spire, up to 10 feet (LF of height)

Miscellaneous Steeple

SSD	Cupola clock (EA face)
SSC	Steeple ball (EA)
SSA	Steeple cross (LF of height)
SSB	Steeple spike (LF of height)

OTHER (29)**STAINED GLASS WINDOWS****Plain Mosaics, Regular Pieces, Few Embellishments**

AGA	Stained glass window (SF area)	Piece size 4 inches and up
AGB	Stained glass window (SF area)	Piece size 2–4 inches
AGC	Stained glass window (SF area)	Piece size under 2 inches

Contemporary Abstract

AGD	Stained glass window (SF area)	Piece size 4 inches and up
AGE	Stained glass window (SF area)	Piece size 2–4 inches
AGF	Stained glass window (SF area)	Piece size under 2 inches

Minimum Painted and Fired Field and Borders—Figures 1 and 2

ABA	Stained glass window (SF area)	Piece size 4 inches and up
ABB	Stained glass window (SF area)	Piece size under 2 inches
ABC	Stained glass window (SF area)	Piece size under 2 inches

Simple Design, Geometric Patterns, Silhouettes—Figure 3

SDA	Stained glass window (SF area)	Piece size 4 inches and up
SDB	Stained glass window (SF area)	Piece size 2–4 inches
SDE	Stained glass window (SF area)	Piece size under 2 inches

Simple Figures and Scenes, Little Detail

SFA	Stained glass window (SF area)	Piece size under 4 inches and up
SFB	Stained glass window (SF area)	Piece size 2–4 inches
SFC	Stained glass window (SF area)	Piece size under 2 inches

Highly Detailed Figures and Scenes—Figure 4

HDA	Stained glass window (SF area)	Piece size 4 inches and up
HDB	Stained glass window (SF area)	Piece size 2–4 inches
HDC	Stained glass window (SF area)	Piece size under 2 inches

Rose or Wheel Windows, Intricate Design—Figure 5

RWA	Stained glass window (SF area)	Piece size 4 inches and up
RWB	Stained glass window (SF area)	Piece size 2–4 inches
RWC	Stained glass window (SF area)	Piece size under 2 inches

Detailed Figure, Large Decorative Background Area—Figure 6

DFA	Stained glass window (SF area)	Piece size 4 inches and up
DFB	Stained glass window (SF area)	Piece size 2–4 inches
DFC	Stained glass window (SF area)	Piece size under 2 inches

OTHER (29)**STAINED GLASS WINDOWS (cont'd)****Faceted Glass, 1" or less Thick, Cast in Epoxy, Contemporary Design—Figures 7 and 8**

FGA	Stained glass window (SF area)	Piece size 4 inches and up
FGB	Stained glass window (SF area)	Piece size 2–4 inches
FGC	Stained glass window (SF area)	Piece size under 2 inches

Faceted Glass, 1 inch or less Thick, Cast in Epoxy Figures and Scenes

FGD	Stained glass window (SF area)	Piece size 4 inches and up
FGE	Stained glass window (SF area)	Piece size 2–4 inches
FGF	Stained glass window (SF area)	Piece size under 2 inches

Faceted Glass, Bound in Concrete, Contemporary Abstract

FGG	Stained glass window (SF area)	Piece size 4 inches and up
FGH	Stained glass window (SF area)	Piece size 2–4 inches
FGJ	Stained glass window (SF area)	Piece size under 2 inches

Faceted Glass, Bound in Concrete, Figures and Scenes

FGK	Stained glass window (SF area)	Piece size 4 inches and up
FGL	Stained glass window (SF area)	Piece size 2–4 inches
FGM	Stained glass window (SF area)	Piece size under 2 inches

Simulated Art Glass

SGP	Acrylic resin panels (SF area)
-----	--------------------------------

Residential Type, Straight Seams

SGA	Clear glass (SF area)	Piece size 14 inches and up
SGB	Clear glass (SF area)	Piece size 10–14 inches
SGC	Clear glass (SF area)	Piece size 6–10 inches
SGD	Clear glass (SF area)	Piece size under 6 inches
SGJ	Multicolor (SF area)	Piece size 14 inches and up
SGK	Multicolor (SF area)	Piece size 10–14 inches
SGL	Multicolor (SF area)	Piece size 6–10 inches
SGM	Multicolor (SF area)	Piece size under 6 inches
SGN	Rondels and accidental designs (SF area)	
SGE	Single color (SF area)	Piece size 14 inches and up
SGF	Single color (SF area)	Piece size 10–14 inches
SGG	Single color (SF area)	Piece size 6–10 inches
SGH	Single color (SF area)	Piece size under 6 inches

OTHER (29)

STAINED GLASS WINDOWS

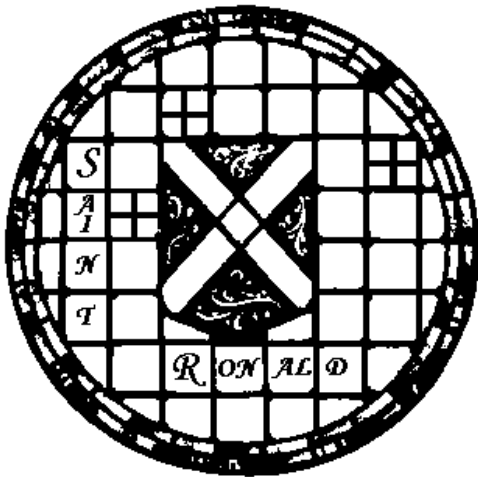
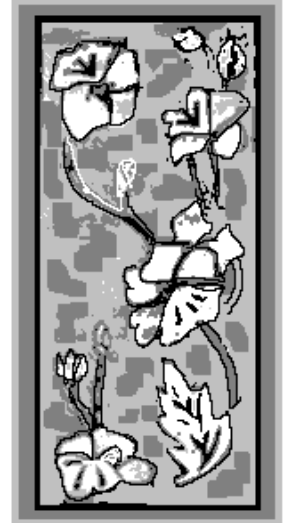
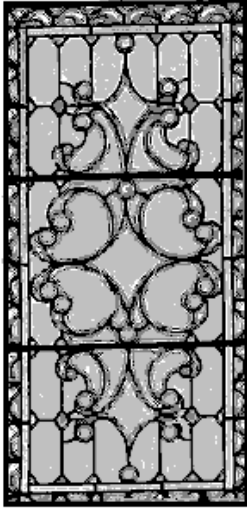

ADDITIONAL COMPONENTS (30)

Bank Components

- ATM Automated teller machine, drive-up or through-wall (EA)
- ATS Automated teller machine, lobby or retail unit (EA)
- UW Bank equipment (SF total building or bank area)
- TWB Drive-up pneumatic tube system (EA Lane)
- TWC Drive-in teller booth (EA)
- TWA Drive-up window (EA) Cost for TWA is included in wall costs for 161-x and 162-x.
- TWD Night deposit chutes or boxes (EA) Cost for TWD is included in the wall costs for 161-x and 162-x.
- TW Rectangular vault door (EA-Rank Table)

TW Rectangular Vault Door Rank Table

THICK (Inch)	RANK	THICK (Inch)	RANK
2	1.0	10	3.0
3	1.3	12	3.3
4	1.7	14	3.7
6	2.0	16	4.0
8	2.5	—	—

Restaurant Components

- UAV Cooking hood and duct system (LF) Use with UAX.
- UDK Fast food window (EA)
- UAX Hood and duct fire extinguishing system (EA Head)

Other

- UDP Pneumatic Tube System (EA Station)

BASEMENTS (31)

The components listed below are those unique to basement costs. Frequently other items of construction or finish will be encountered, such as floors, floor cover, ceilings, plumbing, etc. These are listed by selecting the appropriate items from other component types.

Basement foundations are listed separately from the structure. Subtract 1 from the overall cost rank for both the basement and the structure foundation. For example, if the overall building cost rank is 3, then the cost rank would be 2 for both the basement and structure foundations.

Excavation must be included for the basement area. When calculating cubic feet of excavation, add 3 feet to each side. This will account for the overexcavation necessary for the basement walls. Do not use **BC (site preparation)** in conjunction with **BA (excavation)**. The BC code is only used for structures built on grade.

Basement Walls

- A** Brick masonry wall (SFW of basement) 6–36 inches
- B** Concrete block wall (SFW of basement) 6–36 inches
- C** Concrete reinforced wall (SFW of basement) 6–36 inches
- D** Rubble masonry wall (SFW of basement) 6–36 inches
- F** Stone masonry (SFW of basement) 4–36 inches
- G** Wood, treated (SFW of basement)

ADD—Use in addition to any component selected above.

- H** Insulation (ADD; SFW of basement)
- E** Waterproofing (ADD; SFW of basement)

Basement Interior Construction

- NR** Basement, parking (SF basement area)
- NG** Basement, garage door (EA)
- NH** Church basement, classroom and offices (SF basement area) For churches only
- NK** Church basement, dining hall and kitchen (SF basement area) For churches only
- NJ** Church basement, recreation (SF basement area) For churches only
- NL** Church basement, unfinished (SF basement area) For churches only

Basement Stairs (Residential Only)

- NT** Basement stairs, enclosed (EA flight)
- NS** Basement stairs, open (EA flight)

Basement (Residential Only)

- BST** Basement, unfinished (SF floor) Size: 50 to 4,000 SF

NOTE—Do not adjust foundation for the component BST.

RESIDENTIAL GARAGES (32)

Square Foot of Floor Area Components

The components below include foundation, floor, exterior walls, roof structure and cover, car and pedestrian doors, and electrical. These are restricted to Class C, D, and S and have a size range of 180–4,000 square feet.

GAT	Attached garage (SF garage area)
GBU	Built-in garage (SF garage area)
GDT	Detached garage (SF garage area)
GDTL	Detached garage with living area (SF ground area)

Alternate Components

The components listed below are those unique to garage costs. Other items of construction or finish will be encountered such as foundations, floors, roofs, and electrical. These may be selected from the appropriate component types.

VA	Aluminum siding walls (SFW garage)
VB	Asbestos walls (SFW garage)
VF	Brick veneer walls (SFW garage)
VH	Brick walls (SFW garage)
VK	Concrete block walls (SFW garage)
VI	Face brick walls (SFW garage)
VG	Stone veneer walls (SFW garage)
VJ	Stone walls (SFW garage)
VC	Stucco walls (SFW garage)
VE	Wood shingle walls (SFW garage)
VD	Wood siding walls (SFW garage)

ADD—Use in addition to any component selected above:

VL	Interior finish on walls (ADD; SFW garage)
----	--

Garage Built-ins

VM	Garage door opener (EA)
----	-------------------------

Utility–Storage Buildings

STX	Utility–storage building (SF floor) Size: 600 SF maximum
STXG	Storage building, galvalume (SF floor–rank table)
STXM	Storage building, minimum grade (SF floor) Size: 600 SF maximum

RESIDENTIAL GARAGES (32)

RANK TABLE									
STXG STORAGE BUILDING, GALVALUME									
LENGTH (feet)	WIDTH (feet)								
	16	20	25	30	33	36	40	45	50
20	4.0	—	—	—	—	—	—	—	—
24	3.8	3.6	—	—	—	—	—	—	—
30	3.6	3.3	2.9	—	—	—	—	—	—
36	3.4	2.9	2.8	2.6	2.3	—	—	—	—
40	3.2	2.8	2.6	2.5	2.2	2.5	—	—	—
44	2.8	2.7	2.5	2.3	2.1	2.1	2.1	—	—
50	2.7	2.6	2.5	2.1	2.0	1.9	1.8	1.5	—
60	2.5	2.5	2.1	1.8	1.8	1.8	1.5	1.5	1.5
80	2.4	2.1	1.8	1.5	1.6	1.6	1.3	1.5	1.2
100	2.1	1.8	1.5	1.5	1.5	1.5	1.0	1.0	1.0

RESIDENTIAL CARPORT (33)**Square Foot of Floor Area Component**

The following component includes the cost of the floor structure, roof support system (including posts and beams), and roof cover.

CPT Carport (SF carport area)

Alternate Component

The following component includes the cost for the wood posts to support the roof structure and the column footing that supports the post. Other items such as roof structure and cover, floors, or ceiling must be selected from the appropriate component type and entered on the line provided.

VN Supporting post and beam (SF carport area)

RESIDENTIAL BREEZEWAY (34)

The component costs include the wood posts to support the roof structure and the column footing that supports the post. Other items such as floor, roof structure and cover, and electrical, must be selected from the appropriate component type.

VP Supporting post and beam (SF breezeway area)

SPECIAL COMPONENTS (35)

This component type has no specific component list. There are a number of special applications for components throughout the state. Because these components are unique in their use, these are listed below for easy reference.

COMPONENT		SHORT DESCRIPTION
TYPE	CODE	
04	CAPC	Caisson, concrete (LF)
36	GPUM	Grinder pump (EA)
36	WMR	Guardrail (LF)
36	GHOU	Guest house (SF floor)
20	YURT	Yurt tent home (SF floor)
36	HPBL	Historical preservation building (Dollar amount)
30	UDC	Fiberglass underground fuel/other storage tank (Gallons)
30	UDD	Steel underground fuel/other storage tank (Gallons)
30	UDE	Vertical bulk storage tank, above ground (Gallons)
30	UDF	Horizontal bulk storage tank, above ground (Gallons)
36	UDST	Welded steel fuel tanks (Each @ Barrels)
36	ISTC	Sewage treatment plant, concrete (Gallons/day)
36	ISTS	Sewage treatment plant, steel (Gallons/day)
36	ISX	Septic tank (EA)
36	SCO	Special construction (Dollar amount)
36	SCL	Truck scale (EA @ ton)
36	UPA	Utility piping, pressure pipe, ductile iron (LF)
36	UPB	Utility piping, pressure pipe, cast iron (LF)
36	UPC	Utility piping, pressure pipe, concrete (LF)
36	UPD	Utility piping, pressure pipe, plastic (LF)
36	UPE	Utility piping, pressure pipe, steel (LF)
36	UPF	Utility piping, pressure pipe, valves (EA)
36	UPG	Utility piping, drain and sewer, corrugated metal (LF)
36	UPH	Utility piping, drain and sewer, plastic (LF)
36	UPJ	Utility piping, drain and sewer, plain concrete (LF)
36	UPK	Utility piping, drain and sewer, reinforced concrete (LF)
36	UPL	Utility piping, drain and sewer, vitrified clay (LF)

YARD IMPROVEMENTS (36)

These improvements are constructed separately from the main structure. Use model 101-x for commercial or industrial, and 100-x for residential yard improvements.

Automatic Car Wash

UWC	Canopy (SF)
UWA	Decorative lamps (EA)
UWB	Ornamental pylons (EA)

Drive-in Theater

DTB	Car speaker post (EA)
DTC	Lighting, directional (EA)
DTE	Lighting, ground level (EA)
DTG	Ramp, paved (EA car space)
DTJ	Screen, concrete frame (SF screen area)
DTK	Screen, steel frame (SF screen area)
DTL	Screen, wood frame, braced (SF screen area)
DTM	Screen, wood frame, guyed (SF screen area)
DTN	Screen, wood frame, timbers (SF screen area)
DTT	Ticket booth (EA)

Service Station and Car Wash

PCI	Concrete islands (SF of island)
SIO	Service island office (SF of office) Size 25-300 SF
CPS	Steel canopy (SF area covered)
CPW	Wood canopy (SF area covered)
CPX	Canopy, concrete, double 'T' (SF of canopy)

NOTE—PCI and CPX are restricted to models 171-x and 172-x.

Landscaping

LAC	Landscaped area (SF area)
LAB	Lawn (SF area)
LAS	Sprinkler system (SF area)
LAM	Landscaped desert or grass (SF area)

Parking Lots and Paved Areas

PAS	Paving, asphalt (SF paved area)
PASC	Paving, asphalt, heavy commercial (SF paved area)
PASL	Paving, asphalt, parking lot (UN - each space)
PCO	Paving, concrete, reinforced (SF paved area)
PCU	Paving, concrete, unreinforced (SF paved area)
PAC	Curbing, asphalt (LF)
PCC	Curbing, concrete (LF)
PCM	Parking cover, metal (SF)
PCMG	Multiple Car Parking Cover, metal (SF)
BUM	Parking lot bumper (LF)
RWY	Runway, Airport (SF)
RWYR	Runway Replacement, Airport (SF)

ADD—Use in addition to any component selected above:

PCD	Decorative finish, paved area (ADD, SF)
-----	---

YARD IMPROVEMENTS (36)

Exterior or Parking Lot Lighting

LGL	Exterior lighting, decorative (EA light)
LF	Fluorescent lighting without pole (EA)
LG	High intensity sodium or mercury vapor without pole (EA)
LE	Incandescent lighting without pole (EA)
LH	Light poles for the above lights (LF)
LGP	Lighting (EA 12-foot pole)
LIG	Parking lot lighting (SF area served)

Residential Greenhouse

LJ	Greenhouse (SF greenhouse area) Size 50–1,000 SF
LJC	Greenhouse cooler (ADD; EA)
LJA	Greenhouse heater (ADD; EA)
LJB	Greenhouse humidifier (ADD; EA)

Residential Pools

Residential pool costs are based on the linear feet of perimeter of the pool and include the cost of excavation and pool construction. The costs of required filtering, chlorinating and heating equipment, and diving boards are not included in the base cost and must be entered separately.

SPAE	Aquatic Exercise Pool (UN - EACH)
SPE	Chlorinator (EA)
SPN	Diving board (EA)
SPM	Filter (EA)
SPD	Heater (EA)
SPP	Hydrosweep (EA)
SPI	Solar swimming pool heating (SF of collector)
SPG	Swim pool, concrete (LF of perimeter) Size 50–130 feet
SPF	Swim pool, fiberglass (LF of perimeter) Size 50–130 feet
SPB	Swim pool, gunite (LF of perimeter) Size 50–130 feet
SPH	Swim pool, plastic-lined (LF of perimeter) Size 50–130 feet

Commercial Pools

Commercial pool costs are based on the square foot area of the pool and include the cost of excavation and pool construction. The costs of required filtering, chlorinating and heating equipment, and diving boards are included in the base cost. A cost rank adjustment is required to modify the cost based on both the shape and depth of the pool. Example: a large, square pool would be a rank 1, whereas a small, very irregular pool would be a cost rank 4.

SPK	Swim pool, gunite (SF pool area) Size 900–10,000 SF
SPC	Swim pool, poured concrete (SF pool area) Size 900–10,000 SF

Spas (May be used with residential and commercial.)

SPA	Spa, attached to pool (EA)
SPR	Spa, detached (EA)

YARD IMPROVEMENTS (36)

Fountains

FTB	Fountain bowl, residential (EA)
FTR	Fountain, residential (EA) May use with commercial.
FTP	Fountain pool, commercial (SF of pool area)
FTC	Fountain, commercial (EA)

Railroad Spurs

RRS	Railroad spur (LF)
RRT	Railroad spur, switch and turnout (ADD; EA)

Tennis Court

TCA	Tennis court, asphalt (EA)
TCC	Tennis court, concrete (EA)
TCF	Tennis court, fence (EA court)
TCL	Tennis court, lighting (EA court)

Miscellaneous Yard Improvements

WBR	Barbecue, brick or block (EA)
FLP	Flagpole (LF)
QYR	Ramada (SF area)
QYRM	Ramada, minimum (SF area)
SBC	Shuffleboard court (EA)
TRE	Trash enclosure (EA)

Fencing—Masonry

WAB	Brick wall (SFW)
WAC	Concrete block wall (SFW)
WACS	Concrete block wall, subdivisions (SFW)
WAD	Concrete block wall with stucco (SFW)
WADS	Concrete block wall with stucco, subdivisions (SFW)
WAA	Ornamental screen block wall (SFW)
WAS	Slump stone block wall (SFW)

NOTE—For [split block](#), use WAC and [MEA](#) cost rank 3.

Fencing—Chain Link

WCL	Chain link fence (SF fence area)
WCV	Chain link fence, vinyl coated (SF fence area)

Fencing—Barbed Wire

CASN	Barbed wire fencing (LF)
WCB	Barbed wire (ADD; LF)
WCD	Barbed coil (ADD; LF)

YARD IMPROVEMENTS (36)

Fencing–Wood

WFB	Basket weave fence (LF)
WFP	Picket fence (LF)
WFR	Redwood fence (LF)
WFA	Solid board fence (LF)
WFC	Split rail fence (LF)
WFS	Stockade fence (LF)

Fencing–Metal

WMF	Decorative metal fence (SF fence area)
WMR	Guardrail (LF)

Fencing–Vinyl

WPFV	Picket fence, vinyl (LF)
WPEV	Privacy fence, vinyl (LF)

Fencing–Gates

WCG	Gate, chain link (SF gate area)
WMG	Gate, metal (SF gate area)
WFG	Gate, wood (SF gate area)
WPGV	Gate, vinyl (SF gate area)

Fencing–Stock Corrals

CASE	Horse corral fence (LF)
CASV	Horse corral fence, vinyl (LF)
CASG	Horse corral gate, vinyl (EA)
CASD	Stock corral, gate (EA)
CASC	Stock corral, metal post and rail (LF)
CASB	Stock corral, wood post and rail (LF)
CASX	Cattle feeder/fencing (LF)

Farm Components

Many of the following farm components require a quantity entry that includes both the number of items and the size (capacity) of an individual item.

Vertical Farm Silos

CT	Brick masonry silo (BU capacity) 2,000–60,000 BU
CV	Concrete block silo (BU capacity) 2,000–60,000 BU
CS	Concrete silo (BU capacity) 2,000–60,000 BU
CX	Glass-lined steel silo (BU capacity) 2,000–60,000 BU
CU	Reinforced concrete (BU capacity) 2,000–60,000 BU
CW	Steel silo (BU capacity) 2,000–60,000 BU
CY	Wood silo (BU capacity) 2,000–60,000 BU

YARD IMPROVEMENTS (36)

Horizontal Silos

CPC	Bunker silo, poles and braces (LF length @ LF width) Width 20–80 LF
CPB	Bunker silo, tilt-up (LF length @ LF width) Width 20–80 LF
CPD	Bunker silo, wood (LF length @ LF width) Width 20–80 LF
CPF	Trench silo, poles and braces (LF length @ LF width) Width 20–80 LF
CPE	Trench silo, tilt-up (LF length @ LF width) Width 20–80 LF
CPG	Trench silo, wood (LF length @ LF width) Width 20–80 LF

Farm Storage Bins and Feed Tanks

CR	Feed tanks (BU capacity) 100–6,000 BU
CP	Standard bin without floor (BU capacity) 1,000–35,000 BU

ADD—Use in addition to any component selected above:

CPA	Concrete floor (ADD; feet diameter) 10–40 feet diameter
CRV	Fan and heat, standard bin (ADD; feet diameter) 10–40 feet diameter
CRT	Steel floor (ADD; feet diameter) 10–40 feet diameter
CRU	Ventilated floor (ADD; feet diameter) 10–40 feet diameter

Corn Cribs

CRD	Corn crib, spaced boards on wood skeleton frame (SF area)
CRC	Corn crib, wire mesh on wood skeleton frame (SF area)

Grain Elevators

CRI	Bolted steel tank (BU capacity) 10,000–300,000 BU
CRX	Concrete jump form annex (BU capacity) 50,000–1,500,000 BU
CRW	Concrete jump form elevator (BU capacity) 50,000–1,500,000 BU
CRH	Concrete slip form annex (BU capacity) 50,000–1,500,000 BU
CRG	Concrete slip form elevator (BU capacity) 50,000–1,500,000 BU
CRJ	Corrugated metal bin (BU capacity) 10,000–500,000 BU
CRM	Elevator machinery and equipment (BU capacity) 5,000–1,500,000 BU
CRL	Horizontal storage, steel (BU capacity) 25,000–1,500,000 BU
CRK	Horizontal storage, wood (BU capacity) 25,000–1,500,000 BU
CRF	Wood crib or metal clad annex (BU capacity) 25,000–500,000 BU
CRE	Wood crib or metal clad elevator (BU capacity) 5,000–500,000 BU

YARD IMPROVEMENTS (36)

Miscellaneous Farm Improvements

CAS	Animal shelter (SF area)
CASF	Cattle squeeze (EA)
CASH	Horse walker (EA)
CASI	Water trough (LF)
CASJ	Watering tanks, galvanized (EA)
CASP	Feeding trough, wood, 1-sided bunk (LF)
CASQ	Feeding trough, steel, 1-sided bunk (LF)
CASR	Feeding trough, concrete, 1-sided bunk (LF)
CASS	Feeding trough, wood, 2-sided bunk (LF)
CAST	Feeding trough, steel, 2-sided bunk (LF)
CASU	Feeding trough, concrete, 2-sided bunk (LF)
WEL	Water well (LF of pipe)

ADD—Use in addition to any component selected above:

CASM	Feeding trough roof (ADD; LF)
------	-------------------------------

Mobile Home

MOH	Mobile home, permanently affixed (Dollar amount)
MOHS	Skirting, simulated stone or brick panels (LF)
MOHU	Mobile home / office, not affixed (Dollar amount)
MOHV	Skirting, vinyl or metal (LF)

Mobile Home or Recreational Vehicle Park

MHE	Electric service (EA space)
MHG	Gas service (EA space)
MTT	Water and electric, recreational vehicle (EA space)
MTW	Water service, recreational vehicle (EA space)
MHA	Water and septic (EA space)
MHW	Water and sewer (EA space)

ADD—Use in addition to MHA or MHW:

MHX	Septic treatment, private system (ADD; EA space)
MHT	Sewage treatment, private system (ADD; EA space)
MHP	Site preparation (SF)
PACM	Curbing, asphalt (LF)
PASM	Asphalt paving (SF paved area)
PCCM	Curbing, concrete (LF)
PCUM	Concrete paving, unreinforced (SF paved area)

YARD IMPROVEMENTS (36)**Permanent Crops**

WAP	Apple trees (EA acre)
WCH	Christmas trees (EA acre)
WDA	Date trees (EA acre)
WJO	Jobba plants (EA acre)
WNU	Nut trees (EA acre)
WNP	Pecan trees (EA acre)
WSF	Stone fruit trees (EA acre)
WGR	Vineyards (EA acre)
WCI	Citrus trees (EA acre)
WLT	Lemon trees (EA acre)
WOLV	Olive trees (EA acre)
WOT	Orange trees (EA acre)
WOTM	Orange trees, Minneola (EA acre)
WOTN	Orange trees, navel (EA acre)
WPG	Pink grapefruit trees (EA acre)
WTA	Tangelo trees (EA acre)
WTT	Tangerine trees (EA acre)
WWG	White grapefruit trees (EA acre)

Feedlots

WXA	Base feedlot (EA animal unit)
WXB	Concrete feed trough (EA animal unit)
WXC	Concrete apron (EA animal unit)
WXD	Sun shade (EA animal unit)
WXE	Succor rod post and rail corral (EA animal unit)
WXF	Asphalt feed lane (EA animal unit)
WXG	Sprinkler (EA animal unit)

Feedlots–Miscellaneous

WXH	Concrete dipping vat (LF)
WXI	Loading chute (EA)

YARD IMPROVEMENTS (36)

Golf Courses

Golf Courses

GCD	Golf course, championship (EA hole)
GCJ	Golf course, executive (EA hole)
GCE	Golf course, miniature, budget (EA hole)
GCF	Golf course, miniature, standard (EA hole)
GCA	Golf course, minimal quality (EA hole)
GCH	Golf course, par 3 (EA hole)
GCHE	Golf course, par 3, expensive (EA hole)
GCG	Golf course, pitch and putt (EA hole)
GCC	Golf course, good design (EA hole)
GCB	Golf course, simple design (EA hole)

Tax Year 2011 Statutory Golf Course Per Hole Costs - §42-13152

	Rank 1	Rank 2	Rank 3	Rank 4
GCA-minimal quality	\$31,190	\$31,190	\$31,190	\$31,190
GCB-simple design	\$46,810	\$46,810	\$46,810	\$46,810
GCC-good design	\$63,600	\$63,600	\$63,600	\$63,600
GCD-championship	\$80,460	\$80,460	\$80,460	\$80,460
GCG-pitch & putt	\$14,105	\$14,105	\$14,105	\$14,105
GCH-par 3	\$18,915	\$18,915	\$18,915	\$18,915
GCHE-par 3, expensive	\$24,345	\$24,345	\$24,345	\$24,345
GCJ-executive	\$49,770	\$49,770	\$49,770	\$49,770

Driving Ranges

GCK	Driving range (EA station)
GCL	Driving range cover (ADD; EA station)
GCM	Driving range, heated tee (ADD; EA station)

ADD—Use in addition to any component selected above.

GCP	Bridge, golf cart (SF bridge)
GCN	Bridge, pedestrian (SF bridge)
GCQ	Bridge, vehicular (SF bridge)
GCR	Lake (SF lake area)
GCS	Lake liner, asphalt (ADD; SF lake area)
GCT	Lake liner, clay (ADD; SF lake area)
GCU	Lake liner, concrete (ADD; SF lake area)
GCV	Lake liner, plastic and sand (ADD; SF lake area)
GCX	Lighting (EA pole)
GCW	Player shelter (EA)

**ARIZONA DEPARTMENT OF REVENUE
CONSTRUCTION COST MANUAL**

**SECTION 4
ADJUSTMENTS**

ADJUSTMENTS

The [replacement cost](#) new is adjusted by several factors to obtain the final assessed value of improvements. These adjustments are divided into two groups:

GROUP 1: The adjustment is fixed for each of these and will affect every structure.

- Foundation
- Number of stories
- Story height
- Architectural fees
- Location
- Depreciation
- Market adjustment

GROUP 2: For a discussion of group 2 adjustments refer to Section 2. Certain limits may apply to those listed below.

- [Percent complete](#)
- [Obsolescence](#)
- [Modernization](#)
- [Physical condition](#)

FOUNDATION ADJUSTMENT

This takes into consideration the type of structure, the construction class indicator, and the number of stories when calculating the adjustment for foundation. The foundation costs are based on the total square feet of a building. This factor when applied (usually to multistory structures) will be a negative factor or something less than 1.00.

The "[Detailed Valuation Report](#)", a copy of which follows this discussion, shows the foundation factor applied to the overall structure. This shows as the first item in the component cost adjustment factors block. In the list of components, any code that is adjusted by the foundation factor is identified in a column on the right side of the report under the column labeled "F". The components identified with a "1" are adjusted for cost accordingly.

NUMBER OF STORIES

The building cost for the overall structure is adjusted from the base number of stories. If the base number of stories is 3, then a 1 or 2-story structure will have a factor of less than 1.00. On the other hand, the structure with 4 or more stories will have a factor more than 1.00. The adjustment for number of stories will vary depending on the type of structure, e.g., restaurant, business office or residential, the construction class indicator, and number of stories. This factor shows as the second item in the component cost adjustment factors block.

ADJUSTMENTS

STORY HEIGHT ADJUSTMENT

Components that vary according to the story height are also adjusted. Some examples may include interior construction, and heating and cooling. This adjustment takes into consideration the type of structure, e.g., restaurant, business office or residential, the construction class indicator, and the story height of the structure.

The "[Detailed Valuation Report](#)", a copy of which follows this discussion, shows the story height adjustment factor as the third item in the component cost adjustment factors block. In the list of components, any code that is adjusted by the story height factor is identified in a column on the right side of the report under the column labeled "S". The components identified with a "1" are adjusted for cost accordingly.

ARCHITECTURAL FEES

The overall structure cost is adjusted for the architect fee depending on the type, e.g., restaurant, business office or residential, the construction class indicator, and the construction quality (grade) of the structure. The factor is shown as the fourth item in the component cost adjustment factors block.

ARIZONA DEPARTMENT OF REVENUE
DETAILED IMPROVEMENT VALUATION REPORT
CONSTRUCTION COST MODEL

IMPROVEMENT:	xx	xxx	xx	xxx	x	x	xxxx	xx	MARKET:	xxxx
	CTY	BOOK	MAP	PARC	SPL	CD	IMPR	SECT	AREA-SUBAREA	

BASE FACTORS

MODEL:	1513	DESCRIPTION:	BUSINESS OFFICE	GRADE:	A	CLASS:	C
CONSTR:	1981	DEPREC. CODE:	T5A11L60P04	PERCENT COMPLETE:			1.00
OBSOL:	.00	MODERNIZATION:	1.00	PHYSICAL CONDITION:			1:00

GROUND FLOOR	TOTAL FLOOR	NUMBER OF	PERCENT	AVG. STORY
PERIM AREA	AREA	STORIES	OWNERSHIP	HEIGHT
00430 0005500	000005500	01.0	1.0000	12

COMPONENT COST ADJUSTMENT FACTORS

FOUNDATION:	1.0000	NO. OF STORIES:	0.9880	STORY HT:	1.0000	ARCH. FEE:	1.0650
-------------	--------	-----------------	--------	-----------	--------	------------	--------

COMPONENT LIST

COMP	TYPE	RANK	MISC	UNITS	U/M	DESCRIPTION	COST	F	S
BC	03	2.0		100%	SFF	SITE PREPARATION	752	0	0
CAB	04	2.0		100%	SFF	CONCRETE, BEARING WALL	8044	1	0
WY	06	2.0	8	100%	SFW	STUCCO ON STANDARD BLK	66619	0	0
ML	06	2.0		100%	SFW	BOND BEAMS	3801	0	0
MM	06	2.0		100%	SFW	INSULATION	2552	0	0
QAA	09	2.0	1	100%	SFF	WOOD JOISTS, WOOD DECK	16262	0	0
RD	10	2.0	1	100%	SFF	BUILT-UP COMPOSITION	6366	0	0
RU	10	2.0	1	100%	SFF	INSULATION	3414	0	0
EB	11	2.0		100%	SFF	CONCRETE ON GROUND	12616	0	0
FY	12	2.0		5%	SFF	TILE, CERAMIC	1742	0	0
FE	12	2.0		95%	SFF	CARPET AND PAD	11271	0	0
HA	13	2.0		100%	SFF	INTERIOR CONSTRUCTION	68115	0	1
GCC	14	2.0		100%	SFF	ACOUSTICAL, ORGANIC	6077	0	0
GV	14	2.0		100%	SFF	SUSPENDED CEILING	5151	0	0
IA	15	2.0		100%	SFF	PLUMBING	14931	0	0
KP	17	2.0		100%	SFF	PACKAGE HEATING/COOLING	19850	0	1
LA	18	2.0		100%	SFF	ELECTRICAL	25232	0	0

ADJUSTMENTS

LOCATION ADJUSTMENT

To compensate for differences in building costs from one part of the state to another, a location adjustment is used. This adjustment is applied to the replacement cost new to create a local replacement cost.

The location factor is displayed under the adjustments to base cost section at the end of the component list of the "Detailed Valuation Report." The factor depends on the location and the construction class indicator. There are [location multiplier factors](#) for each county and some cities. These are listed on the following page.

DEPRECIATION TABLES

[Depreciation](#) is the loss in value due to the deterioration of physical components of a structure. The depreciation is based on the type of structure, the construction class indicator, the construction year (effective age), the construction quality (grade), and the typical life expectancy of the structure.

The depreciation code may read T5A11L60P04. This is translated to be:

T	Depreciation table number—5
A	Age—11 years
L	Life expectancy—60 years
P	Percent depreciation—4

MARKET ADJUSTMENT

An 18 percent default factor is applied to all improvements for a market adjustment. This 18 percent does not necessarily represent a valid adjustment for all improvements within each market area. The cost system has the capability to apply any market adjustment by the following:

- Book
- Book and map
- Market area
- Market and subarea
- Model number
- Model number and any combination listed above.

All counties should change the 18 percent default based on their review of the local market conditions each year. Client counties are to submit their market adjustments to the Property Tax Division by the date stated on the [Equalization Calendar of Events](#).

2010 LOCATION MULTIPLIERS*

County	Location	Construction Class Indicators				
		A	B	C	D	S
02	Cochise	0.95	0.92	0.92	0.92	0.92
03	Coconino	1.00	0.97	0.95	0.93	0.95
	Flagstaff	1.06	1.04	1.02	1.00	1.04
	Sedona	1.06	1.05	1.04	1.03	1.04
05	Graham	0.91	0.91	0.91	0.90	0.88
07	Maricopa	0.96	0.95	0.94	0.93	0.94
	Phoenix Metro	0.98	0.97	0.95	0.95	0.95
10	Pima	0.94	0.93	0.91	0.90	0.90
	Tucson	0.95	0.93	0.92	0.92	0.93
11	Pinal	0.91	0.90	0.92	0.92	0.89
13	Yavapai	0.98	0.97	0.96	0.95	0.93
	Prescott	1.04	1.02	1.03	1.03	1.01
	Sedona	1.06	1.05	1.04	1.03	1.04
14	Yuma County	0.96	0.93	0.91	0.90	0.93
	Yuma	0.99	0.96	0.94	0.94	0.97
15	La Paz	0.93	0.91	0.95	0.94	0.90

NOTE: The percentages shown above are to be used for the **2010 valuation year / 2011 tax year**

DEPRECIATION SCHEDULE

ALL MODELS EXCEPT 010x, 011x, 012x, 013x, 014x, 015x, 016x, 017x, 018x, 019x, 028x, 032x, 033x, 034x, 070x, 071x, 072x, 080x thru 089x, 100x, and 881x thru 885x

AGE	LIFE EXPECTANCIES											AGE
	15	20	25	30	35	40	45	50	55	60	70	
1	4	1	1	1	1	1	1	0	0	0	0	1
2	8	3	2	1	1	1	1	1	1	1	0	2
3	12	5	3	2	2	1	1	1	1	1	0	3
4	16	7	4	3	2	2	2	2	1	1	1	4
5	20	10	6	3	3	3	2	2	2	1	1	5
6	24	14	8	5	4	4	3	3	2	2	1	6
7	28	18	11	6	5	5	4	4	3	2	1	7
8	32	23	14	7	6	6	5	5	3	2	1	8
9	36	28	17	9	8	7	6	5	4	3	2	9
10	40	33	20	11	10	8	7	6	4	3	2	10
11	44	38	24	13	12	10	8	7	5	4	2	11
12	48	43	28	16	14	12	9	8	6	4	2	12
13	52	47	32	20	16	14	10	9	6	5	2	13
14	56	51	37	24	18	16	11	10	7	5	3	14
15	60	54	42	28	21	18	12	11	8	6	3	15
16		56	46	31	24	20	13	12	9	7	3	16
17		57	49	34	27	22	14	13	10	7	4	17
18		58	51	37	30	24	16	14	11	8	4	18
19		59	53	40	33	26	18	16	12	9	4	19
20		60	55	43	36	28	19	17	13	9	5	20
21			56	46	39	30	21	18	14	10	5	21
22			57	48	42	33	23	20	15	11	6	22
23			58	50	45	35	25	21	16	12	6	23
24			59	52	47	38	27	23	17	13	7	24
25			60	54	50	40	29	25	19	14	7	25
26				56	52	42	31	27	20	15	8	26
27				57	53	44	33	28	21	16	9	27
28				58	55	46	35	30	23	17	9	28
29				59	56	47	37	32	24	18	10	29
30				60	57	49	40	34	26	20	11	30
31					57	50	42	36	28	21	12	31
32					58	52	44	38	30	22	13	32
33					58	53	46	41	32	24	14	33
34					59	54	49	44	34	25	15	34
35					60	55	51	46	36	27	16	35

NOTE: This schedule was issued in 1989 and will remain in effect until further notice.

DEPRECIATION SCHEDULE

ALL MODELS EXCEPT 010x, 011x, 012x, 013x, 014x, 015x, 016x, 017x, 018x, 019x, 020x 028x, 032x, 033x, 034x, 070x, 071x, 072x, 080x thru 089x, 100x, and 881x thru 885x

AGE	LIFE EXPECTANCIES											AGE
	15	20	25	30	35	40	45	50	55	60	70	
36						56	52	48	38	28	17	36
37						57	54	50	40	30	18	37
38						58	55	52	42	32	19	38
39						59	57	53	44	34	20	39
40						60	57	54	45	35	21	40
41							58	54	46	37	23	41
42							58	55	48	38	25	42
43							59	56	49	40	27	43
44							59	56	51	41	28	44
45							60	57	52	43	30	45
46								58	54	44	31	46
47								58	55	46	33	47
48								59	56	47	34	48
49								59	56	49	36	49
50								60	57	50	38	50
51									58	52	39	51
52									58	53	41	52
53									59	54	42	53
54									59	55	44	54
55									60	56	45	55
56										57	47	56
57										58	48	57
58										59	49	58
59										59	50	59
60										60	52	60
61											53	61
62											54	62
63											55	63
64											56	64
65											57	65
66											58	66
67											58	67
68											59	68
69											59	69
70											60	70

NOTE: This schedule was issued in 1989 and will remain in effect until further notice.

2010 RESIDENTIAL DEPRECIATION SCHEDULE*FOR MODELS 010x, 011x, 012x, 013x, 014x, 015x, 016x, 017x, 018x, 019x, 020x, 028x, 032x,
033x, 034x, 070x, 071x, 072x, 100x, 885x

	Quality	Quality	Quality			Quality	Quality	Quality
	Indicator 2	Indicator 3	Indicator 4			Indicator 2	Indicator 3	Indicator 4
AGE	& Below		& Above		AGE	& Below		& Above
1	.01	.01	.01		36	.29	.26	.18
2	.02	.02	.01		37	.30	.26	.18
3	.02	.02	.02		38	.31	.27	.18
4	.03	.03	.03		39	.32	.27	.19
5	.04	.04	.03		40	.32	.28	.19
6	.05	.05	.04		41	.33	.28	.19
7	.06	.06	.04		42	.34	.29	.20
8	.07	.06	.05		43	.35	.30	.20
9	.07	.07	.06		44	.35	.30	.20
10	.08	.08	.06		45	.36	.31	.21
11	.09	.09	.07		46	.37	.31	.21
12	.10	.09	.07		47	.38	.32	.21
13	.11	.10	.08		48	.39	.32	.22
14	.12	.11	.08		49	.39	.33	.22
15	.12	.12	.09		50	.40	.33	.22
16	.13	.12	.09		51	.40	.34	.23
17	.14	.13	.10		52	.41	.34	.23
18	.15	.14	.10		53	.42	.35	.23
19	.16	.15	.11		54	.42	.35	.24
20	.16	.15	.11		55	.43	.35	.24
21	.17	.16	.12		56	.43	.36	.24
22	.18	.17	.12		57	.44	.36	.25
23	.19	.17	.13		58	.44	.36	.25
24	.20	.18	.13		59	.45	.37	.25
25	.20	.19	.14		60	.45	.37	.26
26	.21	.19	.14		61	.46	.37	.26
27	.22	.20	.14		62	.46	.38	.26
28	.23	.21	.15		63	.47	.38	.27
29	.24	.21	.15		64	.47	.38	.27
30	.24	.22	.16		65	.48	.39	.27
31	.25	.23	.16		66	.48	.39	.28
32	.26	.23	.16		67	.49	.39	.28
33	.27	.24	.17		68	.49	.40	.28
34	.28	.24	.17		69	.50	.40	.28
35	.28	.25	.17		70	.50	.40	.28
					and			
					older			

*NOTE: The percentages shown above are to be used for the 2010 valuation year / 2011 tax year.

2010 DEPRECIATION TABLE FOR FACTORY LIST PRICE MOBILE HOMES AND ADDITIONS*				
Age	Mobile Homes 080x thru 084x	Travel Trailers 085x and 088x	Mobile Offices 087x	Park Models 086x and 089x
0	10	30	1	5
1	10	30	1	5
2	10	30	1	5
3	10	30	5	5
4	11	30	7	7
5	12	36	10	10
6	13	42	11	12
7	14	47	13	13
8	15	50	15	15
9	16	54	17	18
10	17	58	19	21
11	18	62	23	24
12	19	64	27	27
13	20	65	30	30
14	25	65	32	34
15	26	65	38	38
16	27	65	43	43
17	28	65	44	46
18	29	65	46	50
19	30	65	49	53
20	31	65	50	56
21	32	65	51	58
22	33	65	52	59
23	34	65	53	60
24	35	65	54	60
25	35	65	56	60
26	35	65	57	60
27	35	65	59	60
28	35	65	61	60
29	35	65	64	60
30	35	65	67	60
31	35	65	70	60
32	35	65	75	60
33	35	65	80	60
34	36	65	82	60
35	37	65	85	60
36	38	65	90	60
37	39	65	90	60
38	40	65	90	60

Mobile home improvement costs for models 080x (Mobile Home Room Additions) and model 081x (Mobile Home Yard Imps.) will be taken from the Arizona Department of Revenue, Property Tax Division Construction Cost Manual. This value will be multiplied by the **percent good** of the corresponding year using the Mobile Home Schedule.

***NOTE:** The percentages shown above are to be used for the **2010 valuation year / 2011 tax year.**

2010 Mobile Home Square Foot Cost System Depreciation Tables*							
SINGLE WIDE DEP. (Model 881x)				DOUBLE WIDE DEP. (Models 882x, 883x & 884x)			
	Quality	Quality	Quality		Quality	Quality	Quality
	Indicator 2	Indicator 3	Indicator 4		Indicator 2	Indicator 3	Indicator 4
AGE	& Below		& Above	AGE	& Below		& Above
0 and 1	6	5	4	0 and 1	5	3	2
2	6	5	4	2	5	3	2
3	6	5	4	3	5	3	2
4	7	6	5	4	6	5	3
5	9	7	6	5	7	7	4
6	10	9	8	6	8	8	5
7	11	10	9	7	9	9	6
8	12	11	10	8	11	10	7
9	13	14	12	9	12	10	8
10	16	15	13	10	13	11	9
11	17	16	14	11	14	12	10
12	18	17	16	12	15	13	11
13	21	18	17	13	16	14	12
14	23	20	18	14	17	15	13
15	26	22	19	15	18	15	13
16	27	23	20	16	19	16	14
17	29	24	21	17	21	17	15
18	31	25	22	18	22	17	16
19	32	26	23	19	23	18	17
20	33	27	24	20	24	19	18
21	35	28	25	21	25	20	19
22	36	29	26	22	26	22	20
23	38	30	27	23	27	23	21
24	39	32	28	24	28	24	22
25	40	33	29	25	29	24	22
26	42	34	30	26	30	25	23
27	43	35	31	27	32	26	24
28	44	36	32	28	33	28	24
29	45	37	33	29	34	29	25
30	46	38	34	30	35	30	26
31	48	40	35	31	36	31	27
32	49	41	36	32	37	32	28
33	50	42	38	33	38	33	29
34	50	44	39	34	39	34	29
35	50	45	40	35	40	35	30
and older				and older			

*NOTE: The percentages shown above are to be used for the 2010 valuation year / 2011 tax year.

2010 SHOPPING CENTER OBSOLESCENCE / DEPRECIATION SCHEDULE*

AGE	Normal Depreciation	Actual Obsolescence	System Depreciation
1.00	0.00%	1.00%	1%
2.00	0.50%	1.50%	2%
3.00	1.00%	2.00%	3%
4.00	1.50%	2.50%	4%
5.00	2.50%	2.50%	5%
6.00	3.00%	3.00%	6%
7.00	4.00%	3.00%	7%
8.00	5.00%	5.00%	10%
9.00	7.00%	6.00%	13%
10.00	8.00%	8.00%	16%
11.00	9.00%	10.00%	19%
12.00	10.00%	12.00%	22%
13.00	11.00%	14.00%	25%
14.00	12.00%	16.00%	28%
15.00	12.50%	18.50%	31%
16.00	13.50%	20.50%	34%
17.00	14.50%	21.50%	36%
18.00	16.00%	23.00%	39%
19.00	17.50%	24.50%	42%
20.00	18.50%	25.50%	44%
21.00	19.50%	27.50%	47%
22.00	20.00%	29.00%	49%
23.00	21.50%	29.50%	51%
24.00	22.50%	30.50%	53%
25.00	23.50%	31.50%	55%
26.00	25.00%	32.00%	57%
27.00	26.00%	32.00%	58%
28.00	27.50%	32.50%	60%
29.00	28.50%	32.50%	61%
30.00	30.00%	32.00%	62%
31.00	30.50%	31.50%	62%
32.00	31.50%	31.50%	63%
33.00	32.50%	30.50%	63%
34.00	33.50%	29.50%	63%
Age 35.00 and older	34.50%	28.50%	63%

*NOTE: The percentages shown above are to be used for the **2010 valuation year / 2011 tax year**.

COMMERCIAL EXPECTED LIVES

MODEL #	MODEL DESCRIPTION	CLASS	QUALITY INDICATOR					
			1	2	3	4	5	6
035x	Apartment (3 or less stories)	C	50	50	60	70	70	70
		D	45	45	55	60	60	60
		S	50	50	60	60	60	70
036x	Apartment (4 or more stories)	A	60	60	60	70	70	70
		B	60	60	60	70	70	70
		C	55	55	60	60	60	70
		D	50	50	55	60	60	60
		S	50	50	55	60	60	60
037x	Retirement Apartments	A	55	55	60	70	70	70
		B	55	55	60	70	70	70
		C	50	50	55	60	60	60
		D	45	45	50	55	55	55
		S	45	45	50	55	55	55
038x	Assisted Living Apartments	C	55	55	65	65	65	70
		D	50	50	60	60	60	70
		S	50	50	60	60	60	70
041x	Hotel	A	50	50	60	70	70	70
		B	50	50	60	70	70	70
		C	45	45	55	60	60	60
		D	45	45	50	55	55	55
042x	Dormitory	A	55	55	60	70	70	70
		B	55	55	60	70	70	70
		C	50	50	55	70	70	70
		D	45	45	50	60	60	60
		S	45	45	50	60	60	60
043x	Hotel, Full Service	A	55	55	65	70	70	70
		B	55	55	65	70	70	70
		C	50	50	60	60	60	60
		D	45	45	55	55	55	55
044x	Hotel, Limited Service	A	55	55	60	65	65	70
		B	55	55	60	65	65	70
		C	50	50	55	60	60	60
		D	45	45	50	55	55	55
		S	45	45	50	55	55	55

COMMERCIAL EXPECTED LIVES

MODEL #	MODEL DESCRIPTION	CLASS	QUALITY INDICATOR					
			1	2	3	4	5	6
051x	Motel	A	45	45	55	60	60	60
		B	45	45	55	60	60	60
		C	40	40	50	55	55	55
		D	35	35	45	50	50	50
		S	40	40	50	55	55	55
060x	Day Care Center	C	45	45	50	55	55	55
		D	40	40	45	50	50	50
		S	40	40	45	50	50	50
098x	Agricultural Yard Improvements	D	20	20	25	30	30	30
099x	Special Construction Yard Improvements	D	45	45	50	55	55	55
101x	Commercial Yard Improvements	D	45	45	50	55	55	55
102x	Laundry Building	A	45	45	50	55	55	55
		B	45	45	50	55	55	55
		C	40	40	45	50	50	50
		D	35	35	40	45	45	45
		S	35	35	40	45	45	45
103x	Rest Room Building	C	30	30	40	45	45	50
		D	25	25	35	40	40	45
104x	Depot	C	45	45	55	60	60	60
		D	45	45	55	55	55	55
		S	45	45	55	55	55	55
105x	Guardhouse	A	50	50	60	70	70	70
		B	50	50	60	70	70	70
		C	45	45	55	60	60	60
		D	45	45	50	55	55	55
		S	45	45	50	55	55	55
110x	Laundromat-Dry Cleaning Plant	A	45	45	50	55	55	55
		B	45	45	50	55	55	55
		C	40	40	45	50	50	50
		D	35	35	40	45	45	45
		S	35	35	40	45	45	45

COMMERCIAL EXPECTED LIVES

MODEL #	MODEL DESCRIPTION	CLASS	QUALITY INDICATOR					
			1	2	3	4	5	6
111x	Retail Store	A	50	50	60	70	70	70
		B	50	50	60	70	70	70
		C	45	45	55	60	60	60
		D	45	45	50	55	55	55
		S	45	45	50	55	55	55
112x	Supermarket	A	40	40	50	50	50	60
		B	40	40	50	50	50	60
		C	40	40	50	50	50	55
		D	35	35	45	45	45	50
		S	35	35	45	45	45	50
113x	Convenience Market	A	35	35	40	40	40	50
		B	35	35	40	40	40	50
		C	30	30	40	40	40	50
		D	25	25	35	35	35	45
		S	25	25	35	35	35	45
114x	Strip Store	C	40	40	50	55	55	55
		D	35	35	45	50	50	50
		S	35	35	45	50	50	50
115x	Vehicle Sales	A	45	45	55	60	60	60
		B	45	45	55	60	60	60
		C	40	40	50	55	55	60
		D	35	35	45	50	50	55
		S	35	35	45	50	50	55
116x	Barber-Beauty Shop	C	40	40	45	50	50	50
		D	35	35	40	45	45	45
		S	35	35	40	45	45	45
117x	Warehouse Food Store	C	40	40	50	50	50	50
		D	35	35	45	45	45	45
		S	35	35	45	45	45	45
118x	Warehouse Showroom Store	C	40	40	45	50	50	50
		D	35	35	40	45	45	45
		S	35	35	40	40	40	45
119X	Mini-Mart Convenience Store	C	30	30	40	40	40	50
		D	25	25	35	35	35	45
		S	25	25	35	35	35	45

COMMERCIAL EXPECTED LIVES

MODEL #	MODEL DESCRIPTION	CLASS	QUALITY INDICATOR					
			1	2	3	4	5	6
120x	Drugstore	A	45	45	55	55	55	60
		B	45	45	55	55	55	60
		C	40	40	50	50	50	55
		D	35	35	45	45	45	50
		S	35	35	45	45	45	50
130x	Mall Anchor Department Store	A	50	50	60	60	60	60
		B	50	50	60	60	60	60
		C	45	45	55	55	55	60
		D	40	40	50	50	50	55
		S	40	40	50	50	50	55
131x	Department Store	A	55	55	60	70	70	70
		B	55	55	60	70	70	70
		C	50	50	55	60	60	60
		D	50	50	55	60	60	60
132x	Discount Store	A	45	45	50	55	55	55
		B	45	45	50	55	55	55
		C	40	40	45	50	50	50
		D	35	35	40	45	45	45
		S	35	35	40	45	45	45
133x	Warehouse Discount Store	C	40	40	45	50	50	50
		D	35	35	40	45	45	45
		S	35	35	40	45	45	45
134x	Mega-Warehouse Discount Store	C	40	40	45	50	50	50
		S	35	35	40	45	45	45
141x	Neighborhood Shopping Center	C	40	40	50	55	55	55
		D	35	35	45	50	50	50
		S	35	35	45	50	50	50
142x	Community Shopping Center	C	45	45	55	60	60	60
		D	40	40	50	55	55	55
		S	40	40	50	55	55	55
143x	Regional Shopping Center	A	55	55	60	70	70	70
		B	55	55	60	70	70	70
		C	55	55	60	70	70	70
		D	50	50	55	60	60	60
		S	50	50	55	60	60	60

COMMERCIAL EXPECTED LIVES

MODEL #	MODEL DESCRIPTION	CLASS	QUALITY INDICATOR					
			1	2	3	4	5	6
144x	Neigh. Shopping Center-Shell Only	C	40	40	50	55	55	55
		D	35	35	45	50	50	50
		S	35	35	45	50	50	50
145x	Comm. Shopping Center-Shell Only	C	45	45	55	60	60	60
		D	40	40	50	55	55	55
		S	40	40	50	55	55	55
146x	Reg. Shopping Center-Shell Only	A	55	55	60	70	70	70
		B	55	55	60	70	70	70
		C	55	55	60	70	70	70
		D	50	50	55	60	60	60
		S	50	50	55	60	60	60
151x	Business Office	A	55	55	60	70	70	70
		B	55	55	60	70	70	70
		C	50	50	60	70	70	70
		D	45	45	55	60	60	60
		S	45	45	55	60	60	60
152x	Business Office, First Floor Parking	A	55	55	60	70	70	70
		B	55	55	60	70	70	70
		C	50	50	60	70	70	70
		D	45	45	55	60	60	60
		S	45	45	55	60	60	60
153x	Business Office-Shell Only	A	55	55	60	70	70	70
		B	55	55	60	70	70	70
		C	50	50	60	70	70	70
		D	45	45	55	60	60	60
		S	45	45	55	60	60	60
154x	Bus. Office, 1st Floor Parking-Shell Only	A	55	55	60	70	70	70
		B	55	55	60	70	70	70
		C	50	50	60	70	70	70
		D	45	45	55	60	60	60
		S	45	45	55	60	60	60

COMMERCIAL EXPECTED LIVES

MODEL #	MODEL DESCRIPTION	CLASS	QUALITY INDICATOR					
			1	2	3	4	5	6
161x	Central Bank	A	55	55	60	70	70	70
		B	55	55	60	70	70	70
		C	50	50	60	70	70	70
		D	45	45	55	60	60	60
		S	45	45	55	60	60	60
162x	Branch Bank	A	55	55	60	60	60	70
		B	55	55	60	60	60	70
		C	50	50	60	60	60	70
		D	45	45	55	60	60	70
		S	45	45	55	60	60	70
171x	Service Station, Full Service	A	25	25	30	35	35	35
		B	25	25	30	35	35	35
		C	25	25	30	35	35	35
		D	25	25	30	35	35	35
		S	25	25	30	35	35	35
172x	Service Station, Self-Service	C	25	25	30	35	35	35
		D	25	25	30	35	35	35
		S	25	25	30	35	35	35
173x	Car Wash, Drive through	C	25	25	35	40	40	40
		D	20	20	30	35	35	35
		S	25	25	35	40	40	40
174x	Car Wash, Automatic	C	25	25	35	40	40	40
		D	25	25	30	35	35	35
		S	25	25	35	40	40	40
175x	Car Wash, Self-service	C	25	25	35	40	40	40
		D	20	20	30	35	35	35
		S	25	25	35	40	40	40
176x	Mini-Lube Garage	A	45	45	50	55	55	55
		B	45	45	50	55	55	55
		C	40	40	45	50	50	50
		D	35	35	40	45	45	45
		S	35	35	40	45	45	45

COMMERCIAL EXPECTED LIVES

MODEL #	MODEL DESCRIPTION	CLASS	QUALITY INDICATOR					
			1	2	3	4	5	6
178x	Automotive Repair	A	45	45	50	55	55	55
		B	45	45	50	55	55	55
		C	40	40	45	50	50	55
		D	35	35	40	45	45	50
		S	35	35	40	45	45	50
179x	Auto Parts and Service	A	50	50	60	60	60	70
		B	50	50	60	60	60	70
		C	40	40	50	55	55	60
		D	35	35	45	50	50	55
		S	35	35	45	50	50	55
201x	Restaurant, Full Service	A	40	40	50	50	50	55
		B	40	40	50	50	50	55
		C	35	35	45	45	45	50
		D	35	35	45	45	45	50
		S	35	35	45	45	45	50
202x	Restaurant, Fast Food	A	40	40	50	50	50	55
		B	40	40	50	50	50	55
		C	35	35	45	45	45	50
		D	35	35	45	45	45	50
		S	35	35	45	45	45	50
203x	Cocktail Lounge	A	40	40	50	50	50	55
		B	40	40	50	50	50	55
		C	35	35	45	45	45	50
		D	35	35	45	45	45	50
		S	35	35	45	45	45	50
204x	Bar-Tavern	A	40	40	50	50	50	55
		B	40	40	50	50	50	55
		C	35	35	45	45	45	50
		D	35	35	45	45	45	50
		S	35	35	45	45	45	50
205x	Truck Stop	C	35	35	40	45	45	45
		D	35	35	40	45	45	45
		S	35	35	40	45	45	45

COMMERCIAL EXPECTED LIVES

MODEL #	MODEL DESCRIPTION	CLASS	QUALITY INDICATOR					
			1	2	3	4	5	6
210x	Medical-Dental Clinic, First Floor Parking	A	50	50	55	60	60	60
		B	50	50	55	60	60	60
		C	45	45	50	55	55	55
		D	40	40	45	50	50	50
		S	40	40	45	50	50	50
211x	Medical-Dental Clinic	A	50	50	55	60	60	60
		B	50	50	55	60	60	60
		C	45	45	50	55	55	55
		D	40	40	45	50	50	50
		S	40	40	45	50	50	50
212x	Veterinary Clinic	A	45	45	55	55	55	60
		B	45	45	55	55	55	60
		C	40	40	50	50	50	55
		D	35	35	45	45	45	50
		S	35	35	45	45	45	50
213x	Hospital	A	50	50	55	60	60	60
		B	50	50	55	60	60	60
		C	45	45	50	55	55	55
		D	40	40	45	50	50	50
		S	40	40	45	50	50	50
214x	Nursing Home	A	50	50	55	60	60	70
		B	50	50	55	60	60	70
		C	45	45	50	60	60	60
		D	40	40	45	50	50	55
		S	40	40	45	50	50	55
215x	Emergency Medical Dispensary	A	40	40	50	55	55	55
		B	40	40	50	55	55	55
		C	35	35	45	45	45	50
		D	30	30	40	40	40	45
		S	30	30	40	40	40	45

COMMERCIAL EXPECTED LIVES

MODEL #	MODEL DESCRIPTION	CLASS	QUALITY INDICATOR					
			1	2	3	4	5	6
216x	Surgical Center	A	50	50	55	60	60	60
		B	50	50	55	60	60	60
		C	45	45	50	55	55	55
		D	40	40	45	50	50	50
		S	40	40	45	50	50	50
220x	Mortuary	A	50	50	60	60	60	70
		B	50	50	60	60	60	70
		C	45	45	55	55	55	60
		D	40	40	55	55	55	60
		S	40	40	55	55	55	60
240-3	Golf Course*	D	N/A	N/A	N/A	N/A	N/A	N/A
241-3	Golf Course, Non-Statutory*	D	N/A	N/A	N/A	N/A	N/A	N/A
251x	Theater, Walk-in	A	45	45	55	60	60	60
		B	45	45	55	60	60	60
		C	40	40	50	55	55	55
		D	35	35	45	50	50	50
		S	35	35	45	50	50	50
252x	Theater, Drive-in	A	40	40	45	50	50	55
		B	40	40	45	50	50	55
		C	35	35	45	50	50	50
		D	35	35	45	50	50	50
		S	35	35	45	50	50	50
271x	Lodge	A	45	45	55	60	60	60
		B	45	45	55	60	60	60
		C	40	40	50	55	55	60
		D	35	35	45	50	50	55
		S	35	35	45	50	50	55

*Normal depreciation does not apply

COMMERCIAL EXPECTED LIVES

MODEL #	MODEL DESCRIPTION	CLASS	QUALITY INDICATOR					
			1	2	3	4	5	6
272x	Clubhouse	A	50	50	55	60	60	60
		B	50	50	55	60	60	60
		C	45	45	50	60	60	60
		D	40	40	45	50	50	50
		S	40	40	45	50	50	50
273x	Health Club	C	45	45	50	55	55	55
		D	40	40	45	50	50	50
		S	40	40	45	50	50	50
274x	Handball-Racquetball Club	C	45	45	50	55	55	55
		D	40	40	45	50	50	50
		S	40	40	45	50	50	50
275x	City Club-"Y"	A	50	50	60	70	70	70
		B	50	50	60	70	70	70
		C	45	45	55	60	60	60
		D	45	45	55	60	60	60
276x	Bowling Alley	C	40	40	45	50	50	50
		D	35	35	40	45	45	45
		S	35	35	40	45	45	45
277x	Country Club	A	55	55	60	70	70	70
		B	55	55	60	70	70	70
		C	50	50	55	60	60	60
		D	45	45	50	55	55	55
		S	45	45	50	55	55	55
278x	Skating Rink	C	40	40	50	55	55	55
		D	35	35	45	50	50	50
		S	35	35	45	50	50	50
281x	Mobile Home Park	D	45	45	50	55	55	60
282x	Recreational Building	C	45	45	55	60	60	60
		D	45	45	50	55	55	55
		S	45	45	50	55	55	55

COMMERCIAL EXPECTED LIVES

MODEL #	MODEL DESCRIPTION	CLASS	QUALITY INDICATOR					
			1	2	3	4	5	6
283x	Mobile Home-Recreational Vehicle Park	D	45	45	50	55	55	60
284x	Recreational Vehicle Park	D	45	45	50	55	55	60
290x	Parking Lot	D	30	30	30	35	35	35
291x	Parking Garage, Above Grade	A	45	45	50	55	55	55
		B	45	45	50	55	55	55
		C	40	40	45	50	50	50
		S	40	40	45	50	50	50
292x	Parking Garage, Below Grade	A	45	45	55	55	55	60
		B	45	45	55	55	55	60
		C	40	40	50	50	50	55
370x	Warehouse, Transit	A	50	50	60	60	60	70
		B	50	50	60	60	60	70
		C	45	45	55	55	55	60
		D	40	40	50	50	50	55
		S	45	45	55	55	55	60
371x	Warehouse, Storage	A	50	50	60	60	60	70
		B	50	50	60	60	60	70
		C	45	45	55	55	55	60
		D	40	40	50	50	50	55
		S	40	40	50	50	50	55
372x	Warehouse, Distribution	A	50	50	60	70	70	70
		B	50	50	60	70	70	70
		C	45	45	55	60	60	60
		D	40	40	50	55	55	55
		S	40	40	50	55	55	55
373x	Mini-Storage	C	45	45	50	55	55	55
		D	40	40	45	55	55	55
		S	45	45	50	55	55	55

COMMERCIAL EXPECTED LIVES

MODEL #	MODEL DESCRIPTION	CLASS	QUALITY INDICATOR					
			1	2	3	4	5	6
374x	T Hangar, Aircraft	A	50	50	60	60	60	70
		B	50	50	60	60	60	70
		C	35	35	45	50	50	50
		D	35	35	40	45	45	50
		S	35	35	40	45	45	50
375x	Industrial Flex Building	C	45	45	55	55	55	60
		D	40	40	50	50	50	55
		S	40	40	50	50	50	55
376x	Aircraft Storage Hangar	A	40	40	45	50	50	50
		B	40	40	45	50	50	50
		C	35	35	45	50	50	50
		D	35	35	40	45	45	50
		S	35	35	40	45	45	50
377x	Warehouse, Cold Storage	A	50	50	60	60	60	70
		B	50	50	60	60	60	70
		C	45	45	55	55	55	60
		D	40	40	50	50	50	55
		S	40	40	50	50	50	55
378x	Covered Storage, Commercial-Industrial	A	50	50	60	60	60	70
		B	50	50	60	60	60	70
		C	45	45	55	55	55	60
		D	40	40	50	50	50	55
		S	40	40	50	50	50	55
379x	Mega-Warehouse	A	50	50	60	60	60	70
		B	50	50	60	60	60	70
		C	45	45	55	55	55	60
		D	40	40	50	50	50	55
		S	40	40	50	50	50	55
380x	Lumber Storage, Horizontal	C	25	25	35	40	40	40
		D	20	20	30	35	35	35
		S	20	20	30	35	35	35
381x	Equipment Maintenance-Storage	C	25	25	30	35	35	35
		D	20	20	25	30	30	30
		S	20	20	25	30	30	30

COMMERCIAL EXPECTED LIVES

MODEL #	MODEL DESCRIPTION	CLASS	QUALITY INDICATOR					
			1	2	3	4	5	6
382x	Industrial Manufacturing	A	50	50	60	60	60	60
		B	50	50	60	60	60	60
		C	45	45	50	55	55	55
		D	40	40	45	50	50	50
		S	40	40	45	50	50	50
384x	Industrial Manufacturing – Medium	A	55	55	60	70	70	70
		B	55	55	60	70	70	70
		C	50	50	55	60	60	70
		D	45	45	50	55	55	55
		S	45	45	50	55	55	55
385x	Industrial Engineering	A	55	55	60	70	70	70
		B	55	55	60	70	70	70
		C	50	50	55	60	60	70
		D	45	45	50	55	55	55
		S	45	45	50	55	55	55
386x	Industrial Light Manufacturing	A	45	45	50	50	50	55
		B	45	45	50	50	50	55
		C	40	40	40	45	45	50
		D	35	35	35	40	40	45
		S	35	35	35	40	40	45
387x	Industrial Heavy Manufacturing	A	55	55	55	60	60	70
		B	55	55	55	60	60	70
		C	50	50	50	55	55	60
		D	45	45	45	50	50	55
		S	45	45	45	50	50	55
388x	Industrial Building-Shell Only	A	45	45	50	50	50	55
		B	45	45	50	50	50	55
		C	40	40	40	45	45	50
		D	35	35	35	40	40	45
		S	35	35	35	40	40	45
391x	Quonset, Commercial-Industrial	D	15	15	25	30	30	30
		S	15	15	25	30	30	30

COMMERCIAL EXPECTED LIVES

MODEL #	MODEL DESCRIPTION	CLASS	QUALITY INDICATOR					
			1	2	3	4	5	6
400x	Labor Dormitory-Bunk House	C	25	25	35	40	40	40
		D	20	20	30	35	35	40
		S	20	20	30	35	35	40
401x	Dairy	C	25	25	40	45	45	45
		D	25	25	35	40	40	40
		S	20	20	35	40	40	40
405x	Poultry House	C	20	20	30	35	35	40
		D	20	20	25	30	30	35
		S	20	20	25	30	30	35
407x	Greenhouse	D	15	15	30	40	40	40
		S	20	20	35	50	50	50
408x	Hog Finishing-Farrowing Barn	C	25	25	40	40	40	45
		D	20	20	35	40	40	40
		S	20	20	35	40	40	40
412x	Cotton Gin	S	30	30	40	40	40	45
4213	Vineyards*	D	N/A	N/A	N/A	N/A	N/A	N/A
4313	Citrus Trees*	D	N/A	N/A	N/A	N/A	N/A	N/A
4413	Other Tree Crops*	D	N/A	N/A	N/A	N/A	N/A	N/A
4423	Nut Trees*	D	N/A	N/A	N/A	N/A	N/A	N/A
4433	Pecan Trees*	D	N/A	N/A	N/A	N/A	N/A	N/A
4443	Jojoba Plants*	D	N/A	N/A	N/A	N/A	N/A	N/A
4453	Date / Olive Trees*	D	N/A	N/A	N/A	N/A	N/A	N/A
4463	Christmas Trees*	D	N/A	N/A	N/A	N/A	N/A	N/A
450x	Produce Packing Barn	C	30	30	40	40	40	45
		D	25	25	35	35	35	40
		S	25	25	35	35	35	40

*Normal depreciation does not apply

COMMERCIAL EXPECTED LIVES

MODEL #	MODEL DESCRIPTION	CLASS	QUALITY INDICATOR					
			1	2	3	4	5	6
451x	Barn	B	35	35	45	50	50	50
		C	25	25	40	45	45	50
		D	20	20	35	40	40	45
		S	20	20	35	40	40	45
452x	Agricultural Utility Building	C	25	25	30	35	35	35
		D	20	20	25	30	30	30
		S	20	20	25	30	30	30
453x	Horse Arena	C	25	25	40	45	45	50
		D	20	20	35	40	40	45
		S	20	20	35	40	40	45
454x	Hay Shed-Livestock Shelter	C	20	20	30	35	35	35
		D	20	20	25	30	30	30
		S	20	20	25	30	30	30
455x	Horse Stable	C	25	25	40	45	45	50
		D	20	20	35	40	40	45
		S	20	20	35	40	40	45
456x	Quonset, Agricultural	D	15	15	25	30	30	30
		S	15	15	25	30	30	30
491x	Feedlot	D	15	15	15	20	20	25
900x	Post Office	A	60	60	60	70	70	70
		B	60	60	60	70	70	70
		C	55	55	60	70	70	70
		D	50	50	55	60	60	60
		S	50	50	55	60	60	60
901x	Courthouse	A	60	60	70	70	70	70
		B	60	60	70	70	70	70
		C	55	55	60	70	70	70
		D	45	45	50	60	60	60
		S	45	45	50	60	60	60

COMMERCIAL EXPECTED LIVES

MODEL #	MODEL DESCRIPTION	CLASS	QUALITY INDICATOR					
			1	2	3	4	5	6
902x	Library	A	55	55	60	70	70	70
		B	55	55	60	70	70	70
		C	50	50	60	70	70	70
		D	45	45	55	60	60	60
		S	45	45	55	60	60	60
903x	Church	A	50	50	60	70	70	70
		B	50	50	60	70	70	70
		C	45	45	55	60	60	70
		D	40	40	50	55	55	60
		S	40	40	50	55	55	60
904x	Fire Station	A	50	50	55	60	60	60
		B	50	50	55	60	60	60
		C	45	45	50	55	55	55
		D	40	40	45	50	50	50
		S	40	40	45	50	50	50
905x	Prison / Correctional Facility	A	55	55	60	70	70	70
		B	55	55	60	70	70	70
		C	45	45	50	55	55	55
906x	Elementary School (All Buildings)	A	50	50	55	60	60	60
		B	50	50	55	60	60	60
		C	45	45	55	55	55	60
		D	40	40	50	50	50	55
		S	35	35	40	40	40	55
907x	Secondary School (All Buildings)	A	50	50	55	60	60	60
		B	50	50	55	60	60	60
		C	45	45	55	55	55	60
		D	40	40	50	50	50	55
		S	40	40	50	50	50	55

Note: All residential models except 010-0 and mobile home models use sales-based depreciation (see Volume 1, page 111) and expected lives are not considered. The expected life of a 010-0 is 25 years for class C and 20 years for classes D and S.

**ARIZONA DEPARTMENT OF REVENUE
CONSTRUCTION COST MANUAL**

**SECTION 5
MODELS**

LISTED NUMERICALLY AND ALPHABETICALLY

MODELS LISTED NUMERICALLY

010x	Single Family Home	104x	Depot
011x	Guest House	105x	Guardhouse
012x	"A" Frame Home	110x	Laundromat–Dry Cleaning Plant
013x	Log Home	111x	Retail Store
014x	Dome Home	112x	Supermarket
015x	Rammed Earth Home	113x	Convenience Market
016x	Earth Sheltered Home	114x	Strip Store
017x	Envelope Home	115x	Vehicle Sales
018x	Specialty Home	116x	Barber–Beauty Shop
019x	Hillside Home	117x	Warehouse Food Store
020x	Single Family Home, Multi-Story	118x	Warehouse Showroom Store
028x	Factory/Site Built Home	119x	Mini-Mart Convenience Market
032x	Duplex	120x	Drugstore
033x	Triplex	130x	Mall Anchor Department Store
034x	Fourplex	131x	Department Store
035x	Apartment (3 or less stories)	132x	Discount Store
036x	Apartment (4 or more stories)	133x	Warehouse Discount Store
037x	Retirement Apartments	134x	Mega-Warehouse Discount Store
038x	Assisted Living Apartments	141x	Neighborhood Shopping Center
041x	Hotel	142x	Community Shopping Center
042x	Dormitory	143x	Regional Shopping Center
043x	Hotel, Full Service	144x	Neighborhood Shopping Center-Shell Only
044x	Hotel, Limited Service	145x	Community Shopping Center-Shell Only
051x	Motel	146x	Regional Shopping Center-Shell Only
060x	Day Care Center	151x	Business Office
070x	Condominium–Townhouse (Entire Bldg)	152x	Business Office, First Floor Parking
071x	Condominium–Townhouse (Inside Unit)	153x	Business Office-Shell Only
072x	Condominium–Townhouse (End Unit)	154x	Business Office, 1 st Floor Parking-Shell Only
080x	Mobile Home Room Addition	161x	Central Bank
081x	Mobile Home Yard Improvements	162x	Branch Bank
083x	Mobile Home Permanently Affixed	171x	Service Station, Full Service
084x	Mobile Home-Not Affixed	172x	Service Station, Self-service
085x	Travel Trailer-Not Affixed	173x	Car Wash, Drive Through
086x	Park Model-Not Affixed	174x	Car Wash, Automatic
087x	Mobile Office-Not Affixed	175x	Car Wash, Self-service
088x	Travel Trailer Permanently Affixed	176x	Mini-Lube Garage
089x	Park Model Permanently Affixed	178x	Automotive Repair
098x	Agricultural Yard Improvements	179x	Auto Parts and Service
0993	Special Construction Yard Improvements	201x	Restaurant, Full Service
100x	Residential Yard Improvements	202x	Restaurant, Fast Food
101x	Commercial Yard Improvements	203x	Cocktail Lounge
102x	Laundry Building	204x	Bar–Tavern
103x	Rest Room Building	205x	Truck Stop

MODELS LISTED NUMERICALLY

210x	Medical–Dental Clinic, First Floor Parking	387x	Industrial Heavy Manufacturing
211x	Medical–Dental Clinic	388x	Industrial Building–Shell Only
212x	Veterinary Clinic	391x	Quonset, Commercial–Industrial
213x	Hospital	400x	Labor Dormitory–Bunk House
214x	Nursing Home	401x	Dairy
215x	Emergency Medical Dispensary	405x	Poultry House
216x	Surgical Center	407x	Greenhouse
220x	Mortuary	408x	Hog Finishing–Farrowing Barn
2403	Golf Course	412x	Cotton Gin
2413	Golf Course, Non Statutory	4213	Vineyards
251x	Theater, Walk-in	4313	Citrus Trees
252x	Theater, Drive-in	4413	Other Tree Crops
271x	Lodge	4423	Nut Trees
272x	Clubhouse	4433	Pecan Trees
273x	Health Club	4443	Jojoba Plants
274x	Handball–Racquetball Club	4453	Date / Olive Trees
275x	City Club–"Y"	4463	Christmas Trees
276x	Bowling Alley	450x	Produce Packing Barn
277x	Country Club	451x	Barn
278x	Skating Rink	452x	Agricultural Utility Building
281x	Mobile Home Park	453x	Horse Arena
282x	Recreational Building	454x	Hay Shed–Livestock Shelter
283x	Mobile Home–Recreational Vehicle Park	455x	Horse Stable
284x	Recreational Vehicle Park	456x	Quonset, Agricultural
290x	Parking Lot	4913	Feedlot
291x	Parking Garage, Above Grade	881x	Singlewide Mobile Home
292x	Parking Garage, Below Grade	882x	Doublewide Mobile Home
370x	Warehouse, Transit	883x	SF Mobile Home Yard Improvements
371x	Warehouse, Storage	884x	SF Mobile Home Room Addition
372x	Warehouse, Distribution	885x	Recreational Vehicle Support Building
373x	Mini-Storage	900x	Post Office
374x	"T" Hangar, Aircraft	901x	Courthouse
375x	Industrial Flex Building	902x	Library
376x	Aircraft Storage Hangar	903x	Church
377x	Warehouse, Cold Storage	904x	Fire Station
378x	Covered Storage, Commercial–Industrial	905x	Prison / Correctional Facility
379x	Mega-Warehouse	906x	Elementary School (All Buildings)
380x	Lumber Storage, Horizontal	907x	Secondary School (All Buildings)
381x	Equipment Maintenance–Storage		
382x	Industrial Manufacturing		
384x	Industrial Manufacturing–Medium		
385x	Industrial Engineering		
386x	Industrial Light Manufacturing		

MODELS LISTED ALPHABETICALLY

012x	"A" Frame Home	060x	Day Care Center
452x	Agricultural Utility Building	131x	Department Store
098x	Agricultural Yard Improvements	104x	Depot
376x	Aircraft Storage Hangar	132x	Discount Store
035x	Apartment (3 or less stories)	014x	Dome Home
036x	Apartment (4 or more stories)	042x	Dormitory
038x	Assisted Living Apartment	881x	Doublewide Mobile Home
179x	Auto Parts and Service	120x	Drugstore
178x	Automotive Repair	032x	Duplex
204x	Bar–Tavern	016x	Earth Sheltered Home
116x	Barber–Beauty Shop	381x	Equipment Maintenance–Storage
451x	Barn	906x	Elementary School (All Buildings)
276x	Bowling Alley	215x	Emergency Medical Dispensary
162x	Branch Bank	017x	Envelope Home
151x	Business Office	028x	Factory/Site Built Home
152x	Business Office, First Floor Parking	4913	Feedlot
153x	Business Office-Shell Only	904x	Fire Station
154x	Business Office, 1 st Floor Parking-Shell Only	034x	Fourplex
174x	Car Wash, Automatic	2403	Golf Course
173x	Car Wash, Drive Through	2413	Golf Course, Non Statutory
175x	Car Wash, Self-service	407x	Greenhouse
161x	Central Bank	105x	Guardhouse
4463	Christmas Trees	011x	Guest House
903x	Church	274x	Handball–Racquetball Club
4313	Citrus Trees	454x	Hay Shed–Livestock Shelter
275x	City Club–"Y"	273x	Health Club
272x	Clubhouse	019x	Hillside Home
203x	Cocktail Lounge	408x	Hog Finishing–Farrowing Barn
101x	Commercial Yard Improvements	453x	Horse Arena
142x	Community Shopping Center	455x	Horse Stable
145x	Community Shopping Center-Shell Only	213x	Hospital
072x	Condominium–Townhouse (End Unit)	041x	Hotel
070x	Condominium–Townhouse (Entire Bldg)	043x	Hotel, Full Service
071x	Condominium–Townhouse (Inside Unit)	044x	Hotel, Limited Service
113x	Convenience Market	388x	Industrial Building-Shell Only
412x	Cotton Gin	385x	Industrial Engineering
277x	Country Club	375x	Industrial Flex Building
901x	Courthouse	387x	Industrial Heavy Manufacturing
378x	Covered Storage, Commercial–Industrial	386x	Industrial Light Manufacturing
401x	Dairy	382x	Industrial Manufacturing
4453	Date / Olive Trees	384x	Industrial Manufacturing-Medium
		4443	Jojoba Plants
		400x	Labor Dormitory–Bunk House

MODELS LISTED ALPHABETICALLY

102x	Laundry Building	284x	Recreational Vehicle Park
110x	Laundromat–Dry Cleaning Plant	885x	Recreational Vehicle Support Building
902x	Library	143x	Regional Shopping Center
271x	Lodge	146x	Regional Shopping Center-Shell Only
013x	Log Home	100x	Residential Yard Improvements
380x	Lumber Storage, Horizontal	202x	Restaurant, Fast Food
130x	Mall Anchor Department Store	201x	Restaurant, Full Service
211x	Medical–Dental Clinic	103x	Rest Room Building
210x	Medical–Dental Clinic, First Floor Parking	111x	Retail Store
379x	Mega-Warehouse	037x	Retirement Apartments
134x	Mega-Warehouse Discount Store	907x	Secondary School (All Buildings)
176x	Mini-Lube Garage	171x	Service Station, Full Service
119x	Mini-Mart Convenience Market	172x	Service Station, Self-service
373x	Mini-Storage	884x	SF Mobile Home Room Addition
084x	Mobile Home-Not Affixed	883x	SF Mobile Home Yard Improvements
281x	Mobile Home Park	010x	Single Family Home
083x	Mobile Home Permanently Affixed	020x	Single Family Home, Multi-Story
283x	Mobile Home–Recreational Vehicle Park	881x	Singlewide Mobile Home
080x	Mobile Home Room Addition	278x	Skating Rink
081x	Mobile Home Yard Improvements	0993	Special Construction Yard Improvements
087x	Mobile Office-Not Affixed	018x	Specialty Home
220x	Mortuary	114x	Strip Store
051x	Motel	112x	Supermarket
141x	Neighborhood Shopping Center	216x	Surgical Center
144x	Neighborhood Shopping Center-Shell Only	374x	"T" Hangar, Aircraft
214x	Nursing Home	252x	Theater, Drive-in
4423	Nut Trees	251x	Theater, Walk-in
4413	Other Tree Crops	085x	Travel Trailer-Not Affixed
086x	Park Model-Not Affixed	088x	Travel Trailer Permanently Affixed
089x	Park Model Permanently Affixed	033x	Triplex
291x	Parking Garage, Above Grade	205x	Truck Stop
292x	Parking Garage, Below Grade	115x	Vehicle Sales
290x	Parking Lot	212x	Veterinary Clinic
4433	Pecan Trees	4213	Vineyards
900x	Post Office	377x	Warehouse, Cold Storage
405x	Poultry House	133x	Warehouse Discount Store
905x	Prison / Correctional Facility	372x	Warehouse, Distribution
450x	Produce Packing Barn	117x	Warehouse Food Store
456x	Quonset, Agricultural	118x	Warehouse Showroom Store
391x	Quonset, Commercial–Industrial	371x	Warehouse, Storage
015x	Rammed Earth Home	370x	Warehouse, Transit
282x	Recreational Building		

MODEL 010 - 0**SINGLE FAMILY RESIDENCE**

- Features:** Minimum quality residence. Built of low cost or used materials. Small in size with plain and inexpensive interiors. Usually a small home with no ornamentation or trim. Structure most likely will not meet building code requirements. Architectural design is simple and primarily concerned with function rather than appearance.
- Foundation:** Continuous concrete [perimeter](#) or concrete block or [piers](#).
- Exterior Walls:** Minimal [fenestration](#) with little or no trim.
- Roof Structure / Cover:** Prefabricated trusses or rafters with inexpensive sheathing and a lightweight composition shingle or a built-up with gravel cover. Slope is usually less than 4 in 12 with no eaves.
- Floor Structure / Cover:** Concrete slab on grade or wood structure with no insulation. Floor cover is of low quality.
- Interior Finish:** Interior walls and ceilings are inexpensive gypsum board taped and painted. Kitchens and baths may have enamel painted ceilings and walls. Cabinets are paint grade wood or metal. Countertops are low cost [laminated plastic](#). Doors are [hollow core](#) with low cost hardware. Closet space is minimal.
- Plumbing:** Minimal plumbing. May or may not meet building code requirements.
- Heating / Cooling:** Wall unit heating of low quality. [Evaporative cooling](#), if any.

MODEL 010 - 0

SINGLE FAMILY RESIDENCE

(continued)

Electrical:

Finished electrical, minimum number of outlets, and low cost lighting fixtures. May or may not meet minimum building code requirements.

Porches / Patios:

Porches and patios are similar in quality of material and workmanship to the main residence.

Garages / Carports:

Garages and carports are similar in quality of material and workmanship to the main residence.

MODEL 010 - 0 ILLUSTRATIONS



MODEL 010 - 0 ILLUSTRATIONS



MODEL 010 - 1**SINGLE FAMILY RESIDENCE****Features:**

Minimum quality residence. Low cost structures may or may not meet minimum building code requirements. Interior finish is plain and inexpensive with little detail. Architectural design is simple and primarily concerned with function rather than appearance.

Foundation:

Continuous concrete [perimeter](#) or concrete block.

Exterior Walls:

Minimal [fenestration](#) and inexpensive [sash](#) with little or no trim.

Roof Structure / Cover:

[Rafters](#) or prefabricated [trusses](#) with plywood or other inexpensive [sheathing](#) and lightweight composition shingle or a built-up with gravel cover. Slope is usually 4 in 12 or less with no eaves.

Floor Structure / Cover:

Concrete slab on grade or wood structure with no insulation. Inexpensive [vinyl composition tile](#).

Interior Finish:

Interior walls and ceilings are inexpensive gypsum board taped and painted with insulated ceilings. Kitchens and baths may have enamel painted ceilings and walls. Cabinets are paint grade wood or vinyl veneer. Countertops are low cost [laminated plastic](#). Doors are hollow core with inexpensive hardware. Minimal amount of closet space.

Plumbing:

Low cost plumbing fixtures with rough-in.

Heating / Cooling:

[Evaporative cooling](#). Typically wall or window units.

»»» continued on next page »»»

MODEL 010 - 1**SINGLE FAMILY RESIDENCE****(continued)****Electrical:**

Finished electrical with a minimum number of outlets and low cost lighting fixtures.

Porches / Patios:

Porches and patios are similar in quality of material and workmanship to the main residence.

Garages / Carports:

Garages and carports are similar in quality of material and workmanship to the main residence.

MODEL 010 - 1 ILLUSTRATIONS



MODEL 010 - 1 ILLUSTRATIONS



MODEL 010 - 2**SINGLE FAMILY RESIDENCE**

- Features:** Frequently mass produced with low cost as the primary consideration. Quality of materials and workmanship is below average, but meets minimum building code requirements. Interior finish is plain with few refinements. Design is from stock plans and ornamentation is limited to the front elevation.
- Foundation:** Continuous concrete [perimeter](#) or concrete block.
- Exterior Walls:** Moderate [fenestration](#) with inexpensive [sash](#). Front [elevation](#) may have inexpensive trim.
- Roof Structure / Cover:** [Rafters](#) or prefabricated [trusses](#) with plywood or other inexpensive [sheathing](#) with a lightweight composition shingle or a built-up with gravel cover. Slope is usually 4 in 12 or less with minimal eaves.
- Floor Structure / Cover:** Concrete slab on grade or wood structure. Low quality [vinyl composition tile](#), carpet and pad.
- Interior Finish:** Interior walls and ceilings are gypsum board taped and painted with insulated ceilings. Kitchens and baths may have enamel painted ceilings and walls. Inexpensive stock cabinets of paint grade wood or vinyl veneer in kitchen with [laminated plastic](#) countertops. Stock hollow-core doors with inexpensive hardware. Minimal amount of closet space.
- Plumbing:** Low cost plumbing fixtures with rough-in.
- Heating / Cooling:** A forced air furnace with minimal output and ductwork. Evaporative cooler with ductwork.

>>>> continued on next page >>>>

MODEL 010 - 2**SINGLE FAMILY RESIDENCE****(continued)****Electrical:**

Finished electrical with a minimum number of outlets and low cost lighting fixtures which meets minimum building code requirements.

Porches / Patios:

Porches and patios are similar in quality of material and workmanship to the main residence.

Garages / Carports:

Garages and carports are similar in quality of material and workmanship to the main residence.

MODEL 010 - 2 ILLUSTRATIONS



MODEL 010 - 2 ILLUSTRATIONS



MODEL 010 - 3**SINGLE FAMILY RESIDENCE****Features:**

Average quality residence. Usually mass-produced and will meet or exceed minimum building code standards. The average quality residence will be encountered more frequently than any other type. Quality of materials and workmanship is acceptable, but does not reflect custom craftsmanship. Architectural design will include ample fenestration and some ornamentation on the front elevation.

Foundation:

Continuous concrete perimeter or concrete block or piers.

Exterior Walls:

Ample fenestration using aluminum or wood sash with minimal ornamental trim.

Roof Structure / Cover:

Prefabricated trusses with exterior grade plywood or wood sheathing, with a medium grade composition shingle or a built-up small rock roof cover. Slope is usually 5 in 12 or less.

Floor Structure / Cover:

Wood structure and subfloor on first and upper floors, or concrete slab on first floor and wood on upper floors.

Interior Finish:

Interior walls and ceilings are gypsum board taped and painted with some inexpensive wallpaper or paneling and insulated ceilings. Kitchens and baths may have enamel painted ceilings and walls. Cabinets are prefinished plywood with a small vanity in bath areas. Countertops are laminated plastic or ceramic tile. Doors are medium grade hollow core with standard grade hardware. Baseboards and casings are stock. Closet space is adequate.

Plumbing:

Standard plumbing fixtures with rough-in.

>>>> continued on next page >>>>

MODEL 010 - 3**SINGLE FAMILY RESIDENCE****(continued)****Heating / Cooling:**

Heat pump or forced air furnace with adequate output and ductwork. [Evaporative cooling](#) or air conditioning.

Electrical:

Finished electrical with an adequate number of outlets and some luminous lighting fixtures in the kitchen and bath areas.

Porches / Patios:

Porches and patios are similar in quality of material and workmanship to the main residence.

Garages / Carports:

Garages and carports are similar in quality of material and workmanship to the main residence.

MODEL 010 - 3 ILLUSTRATIONS



MODEL 010 - 3 ILLUSTRATIONS



MODEL 010 - 3 ILLUSTRATIONS



MODEL 010 - 3 ILLUSTRATIONS





MODEL 010 - 3 ILLUSTRATIONS



MODEL 010 - 4**SINGLE FAMILY RESIDENCE****Features:**

Good quality residence. May be mass produced in above average residential developments or built for an individual owner. Good quality materials are used throughout. Generally, these homes exceed the minimum building codes. Some attention is given to architectural design in both refinements and detail. Interiors are finished with good quality wallpaper or paneling. Exteriors have good fenestration with some ornamentation or other refinements.

Foundation:

Continuous concrete perimeter or concrete block or piers.

Exterior Walls:

Good fenestration using good quality sash with some ornamental trim.

Roof Structure / Cover:

Wood rafters and sheathing with hips and valleys. Roof cover is usually good quality composition shingle, concrete tile or cedar shingles.

Floor Structure / Cover:

Wood or steel floor joists and subfloor on first and upper floors, or concrete slab on grade and wood or steel floor joists on upper floors.

Interior Finish:

Interior walls and ceilings are gypsum board taped and painted with some good quality wallpaper or wood paneling. Kitchens and baths have enamel painted ceilings and walls. Ample cabinets have a natural wood veneer finish in the kitchen and pullman or vanity in the baths. Countertops and splash are laminated plastic, ceramic tile, or simulated marble. Doors are good quality hollow core with attractive hardware. Baseboards and casings are hardwood or softwood and have mitered corners. Walk-in closets or large sliding door wardrobes. Ample linen and storage closets.

>>>> continued on next page >>>>

MODEL 010 - 4**SINGLE FAMILY RESIDENCE****(continued)****Plumbing:**

Good quality plumbing fixtures with rough-in.

Heating / Cooling:[Heat pump](#) or forced air furnace and air conditioning with adequate output and ductwork to all main areas.**Electrical:**

Good amount of convenience outlets with luminous fixtures in kitchen and bath areas.

Porches / Patios:[Porches](#) and [patios](#) are similar in quality of material and workmanship to the main residence.**Garages / Carports:**

Garages and carports are similar in quality of material and workmanship to the main residence.

MODEL 010 - 4 ILLUSTRATIONS



MODEL 010 - 4 ILLUSTRATIONS



MODEL 010 - 4 ILLUSTRATIONS



MODEL 010 - 4 ILLUSTRATIONS



MODEL 010 - 5**SINGLE FAMILY RESIDENCE****Features:**

Very good quality residence. These homes are typical of those built in high quality subdivisions or developments. Most often these are individually designed. Considerable attention has been given to interior refinements and detail. Exteriors have good [fenestration](#) with some custom ornamentation.

Foundation:

Continuous concrete [perimeter](#) and interior bearing wall foundation.

Exterior Walls:

Fenestration is well designed with high quality [sash](#). Custom ornamentation and trim are used.

Roof Structure / Cover:

Wood [rafters](#) and [sheathing](#). Roof cover is high quality composition shingle, concrete tile, or heavy wood shake.

Floor Structure / Cover:

Wood or steel floor [joists](#) and [subfloor](#) on first and upper floors, or concrete slab on grade and wood or steel floor joists on upper floors.

Interior Finish:

Interior walls and ceilings are gypsum board tape and painted with high grade paper or vinyl wall covering, [hardwood](#) paneling, or ceramic tile. Ample amount of cabinets which may include such specialty cabinetry as cooking island, wet bar, or desk. High quality pullman or vanity cabinets. Countertops and splash are highest quality [laminated plastic](#) or ceramic tile. Doors are raised panel [hardwood veneer](#) or enameled with good quality hardware. [Baseboards](#), [casings](#), and moldings have tight mitered corners. Spacious walk-in closets or wardrobes and large linen storage closets.

MODEL 010- 5**SINGLE FAMILY RESIDENCE****(continued)****Plumbing:**

High quality plumbing fixtures with rough-in.

Heating / Cooling:[Heat pump](#) or forced air furnace and air conditioning with adequate output and ductwork to all main areas.**Electrical:**

Well-positioned outlets and high quality fixtures throughout. Good luminous fixtures in kitchen and bath areas.

Porches / Patios:[Porches](#), [patios](#), and exterior [balconies](#) are similar in quality to that of the residence.**Garages / Carports:**[Garages](#) are high quality with reinforced concrete slab on grade, pedestrian and overhead doors, ornamentation, windows, and electrical lighting.

MODEL 010 - 5 ILLUSTRATIONS



MODEL 010 - 5 ILLUSTRATIONS



MODEL 010 - 5 ILLUSTRATIONS



MODEL 010 - 5 ILLUSTRATIONS



MODEL 010 - 6**SINGLE FAMILY RESIDENCE****Features:**

Residences of excellent quality are usually individually designed and are characterized by the high quality of workmanship, finishes, appointments, and considerable attention to detail. Homes at this quality level are inclusive of high quality material and workmanship, and are unique in their architectural design. These may not represent the highest cost in residential construction.

Foundation:

Continuous concrete [perimeter](#) and interior [bearing wall](#) foundation.

Exterior Walls:

[Fenestration](#) is well designed with high quality [sash](#). Custom ornamentation and trim; e.g., select brick, cut stone, high quality siding are used.

Roof Structure / Cover:

Wood [rafters](#) and [sheathing](#). Roof cover may be high quality [clay tile](#) or [slate](#) roof.

Floor Structure / Cover:

Wood or steel floor [joists](#) and [subfloor](#) on first and upper floors, or concrete slab on grade and wood or steel floor joists on upper floors.

Interior Finish:

Interior walls and ceilings are gypsum board taped and painted with high grade paper or vinyl wall covering, [hardwood](#) paneling, or ceramic tile. Built-in book shelving and ample amount of cabinets which may include such specialty cabinetry as cooking island, wet bar, and desk. High quality pullman or vanity cabinets in bath and dressing areas. Countertops and splash are highest quality [laminated plastic](#), marble, or ceramic tile. Doors are raised panel [hardwood](#) veneer or enameled with good quality hardware. [Baseboards](#), [casings](#), and [moldings](#) have tight mitered corners. Walk-in closets or wardrobes with many built-in features. Large linen storage closets and pantry are fully shelved.

»»» continued on next page »»»

MODEL 010- 6**SINGLE FAMILY RESIDENCE****(continued)****Plumbing:**

High quality plumbing fixtures with rough-in.

Heating / Cooling:[Heat pump](#) or forced air furnace and air conditioning with multiple controls. Large capacity with insulated ductwork to all main areas.**Electrical:**

Many well positioned outlets and high quality fixtures throughout. Large high quality luminous fixtures in kitchen, bath, and dressing areas.

Porches / Patios:[Porches](#), [patios](#), and exterior [balconies](#) are similar in quality to that of the residence.**Garages / Carports:**[Garages](#) are high quality with reinforced concrete slab on grade, pedestrian and overhead doors, ornamentation, windows, and electrical lighting.

MODEL 010 - 6 ILLUSTRATIONS



MODEL 010 - 6 ILLUSTRATIONS

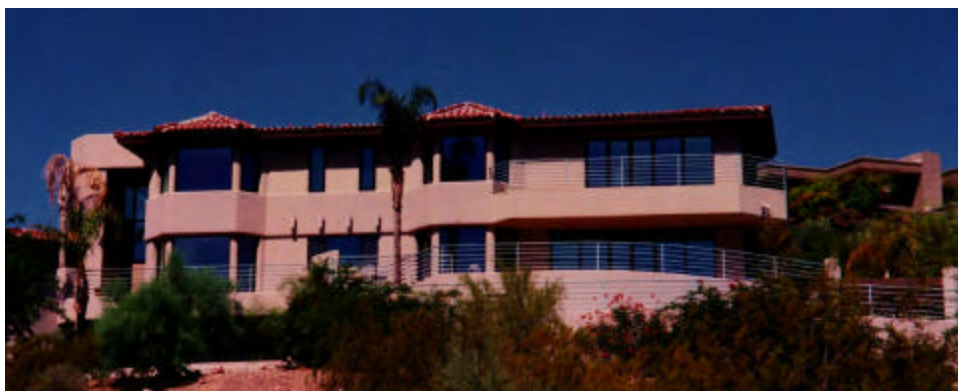

MODEL 010 - 6 ILLUSTRATIONS



MODEL 010 - 6 ILLUSTRATIONS



MODEL 010 - 7**SINGLE FAMILY RESIDENCE****Features:**

Residence of excellent quality are usually individually designed and are characterized by high quality of workmanship, finishes, appointments, and considerable attention to detail. Homes at this quality level are inclusive of high quality material and workmanship, and are unique in their architectural design. These may not represent the highest cost in residential construction.

Foundation:

Continuous concrete [perimeter](#) and interior [bearing wall](#) foundation.

Exterior Walls:

[Fenestration](#) is well designed with high quality [sash](#). Custom ornamentation and trim; e.g., select brick, cut stone, high quality siding are used.

Roof Structure / Cover:

Wood [rafters](#) and [sheathing](#). Roof cover may be high quality [clay tile](#) or [slate](#) roof.

Floor Structure / Cover:

Wood or steel floor [joists](#) and [subfloor](#) on first and upper floors, or concrete slab on grade and wood or steel floor joists on upper floors.

Interior Finish:

Interior walls and ceilings are gypsum board taped and painted with high grade paper or vinyl wall covering, [hardwood](#) paneling, or ceramic tile. Built-in book shelving and ample amount of cabinets which may include such specialty cabinetry as cooking island, wet bar, and desk. High quality pullman or vanity cabinets in bath and dressing areas. Countertops and splash are highest quality [laminated plastic](#), marble, or ceramic tile. Doors are raised panel [hardwood veneer](#) or enameled with good quality hardware. [Baseboards](#), [casings](#), and [moldings](#) have tight mitered corners. Walk-in closets or wardrobes with many built-in features. Large linen storage closets and pantry are fully shelved.

»»» continued on next page »»»

MODEL 010- 7**SINGLE FAMILY RESIDENCE****(continued)****Plumbing:**

High quality plumbing fixtures with rough-in.

Heating / Cooling:[Heat pump](#) or forced air furnace and air conditioning with multiple controls. Large capacity with insulated ductwork to all main areas.**Electrical:**

Many well positioned outlets and high quality fixtures throughout. Large high quality luminous fixtures in kitchen, bath and dressing areas.

Porches / Patios:[Porches](#), [patios](#), and exterior [balconies](#) are similar in quality to that of the residence.**Garages / Carports:**[Garages](#) are high quality with reinforced concrete slab on grade, pedestrian and overhead doors, ornamentation, windows, and electrical lighting.

MODEL 010 - 7 ILLUSTRATIONS



MODEL 010 - 7 ILLUSTRATIONS



MODEL 010 - 7 ILLUSTRATIONS



MODEL 010 - 7 ILLUSTRATIONS



MODEL 011 - X**GUEST HOUSE**

- Features:** A self-contained living unit separate from the main residence usually meeting or exceeding minimum building code standards. Average quality guest houses will be encountered more frequently than any other type. Quality of materials and workmanship will be similar to the main residence. A detailed baseline including [perimeter](#), square footage, and average story height should be completed. Note: component [GHOU - Guest House](#) - includes costs for exterior walls, roof structure, roof cover, floor, floor cover, plumbing, heat pump, and electrical.
- Foundation:** Continuous concrete perimeter or concrete block or [piers](#).
- Exterior Walls:** Exterior walls are similar in quality of material and workmanship to the main residence.
- Roof Structure / Cover:** Prefabricated [trusses](#) with exterior grade plywood or wood [sheathing](#) with a composition shingle or a built-up small rock roof cover.
- Floor Structure / Cover:** Concrete slab on grade or wood floor. [Vinyl composition tile](#) with carpet and pad floor cover.
- Interior Finish:** Interior finish is similar in quality of material and workmanship to the main residence.
- Plumbing:** Plumbing fixtures are similar in quality of material and workmanship to the main residence.
- Heating / Cooling:** [Heat pump](#) or forced air furnace with adequate output and ductwork. [Evaporative cooling](#) or air conditioning.
- Electrical:** Finished electrical with adequate number of outlets and some luminous lighting fixtures in kitchen and bath areas.

»»» continued on next page »»»

MODEL 011 - X**Guest House****(continued)****Porches / Patios:**

[Porches](#) and [patios](#) are similar in quality of material and workmanship to the main residence.

Garages / Carports:

[Garages](#) and [carports](#) are similar in quality of material and workmanship to the main residence.

MODEL 011 - X ILLUSTRATIONS



MODEL 011 - X ILLUSTRATIONS



MODEL 012 - X**"A" FRAME HOME****Features:**

The "A" frame residence uses heavy wood or [laminated beams](#) to provide both exterior wall and roof structure with common beams. The design with its steep roof slope appears similar to the letter "A", hence the name. Occasionally, vertical sidewalls are used to increase the usable first-floor area. Interiors are conventional and may have a [loft](#). Foundations are conventional. The "A" frame is most prevalent in the higher altitudes because its steep roof slope prevents heavy snow loads from accumulating on the roof structure.

Foundation:

Continuous concrete [perimeter](#) or concrete block or [piers](#).

Exterior Walls:

End walls will typically be wood or hardboard sided. Vertical sidewalls may or may not be present. Lower quality "A" frames will have minimal [fenestration](#) while higher grades will have large double or triple paned windows.

Roof Structure / Cover:

A full frame where wooden structural members (wood timbers or laminated beams) totally support the home in an "A" configuration. Use frame/structure component [DU \(Wood "A" Frame\)](#). Typical roof cover is wood or composition shingle. [Dormers](#) may or may not be present.

Floor Structure / Cover:

Concrete on ground or wood structure. Average quality "A" frames will have [vinyl composition tile](#) with carpet and pad while higher grades may have [hardwood](#) with ceramic floor cover.

Interior Finish:

Interior finish will show no appreciable differences from conventional construction of the same quality. (See single family home model descriptions of similar quality grade.)

>>>> continued on next page >>>>

MODEL 012 - X**"A" FRAME HOME****(continued)****Plumbing:**

Plumbing fixtures of a type and number commensurate with the construction quality. (See single family home model descriptions of similar quality grade.)

Heating / Cooling:

The type and extent of heating and cooling will largely depend on whether the home is occupied year-round or seasonally, and will range from none to a single wood stove to a complete forced air heating and cooling system.

Electrical:

Finished electrical of a type and quantity commensurate with the construction quality. (See single family home model descriptions of similar quality grade.)

Porches / Patios:

[Porches](#) and [patios](#) are similar in quality of material and workmanship to the residence.

Garages / Carports:

[Garages](#) and [carports](#) are similar in quality of material and workmanship to the residence.

MODEL 012 - X ILLUSTRATIONS



MODEL 012 - X ILLUSTRATIONS



MODEL 013 - X**LOG HOME****Features:**

This residential structure uses logs as the exterior [load-bearing wall](#). There are several different log assembly systems offered as kits or built by a licensed contractor. Other than exterior walls, construction techniques for this type of residence will have no appreciable difference from conventional single family residences.

Foundation:

Continuous concrete [perimeter](#) or concrete block or [piers](#).

Exterior Walls:

Typically, the exterior walls are of solid wood construction, using 5-inch or 6-inch diameter logs with [tongue and groove](#) peeled to a clean wood finish, then spiked and doweled using weather sealant or caulking. Logs are pretreated with a preservative. Use wall component [MAS \(Rustic log\)](#).

Roof Structure / Cover:

Prefabricated [trusses](#) with exterior grade plywood or wood [sheathing](#) with composition or wood shingle.

Floor Structure / Cover:

Wood structure and [subfloor](#) on first and upper floors, or concrete slab on first floor and wood on upper floors.

Interior Finish:

Interior finish will show no appreciable differences from conventional construction of the same quality. (See single family home model descriptions of similar quality grade.)

Plumbing:

Plumbing fixtures of a type and number commensurate with the construction quality. (See single family home model descriptions of similar quality grade.)

>>>> continued on next page >>>>

MODEL 013 - X**LOG HOME****(continued)****Heating / Cooling:**

The type of heating and cooling will largely depend on whether the home is occupied year-round or seasonally and will range from none to a single wood stove to a complete forced air heating and cooling system.

Electrical:

Finished electrical of a type and quantity commensurate with the construction quality. (See single family home model descriptions of similar quality grade.)

Porches / Patios:

[Porches](#) and [patios](#) are similar in quality of material and workmanship to the residence.

Garages / Carports:

[Garages](#) and [carports](#) are similar in quality of material and workmanship to the residence.

MODEL 013 - X ILLUSTRATIONS



MODEL 013 - X ILLUSTRATIONS



MODEL 014 - X**DOME HOME****Features:**

This structure is dome shaped and made from lightweight members connected to form a grid of interlocking polygons. Dome homes are typically purchased as kits from a manufacturer.

Foundation:

Continuous concrete [perimeter](#) or concrete block or [piers](#).

Exterior Walls:

Wall construction may be panels, sections of wood or Styrofoam; or may be steel frame; or [balloon](#) type with concrete or foam sprayed in place. Most commonly covered with wood or asphalt shingles. For procedure to calculate the square feet of surface area, refer to [component type 6 in Volume 1, Section 3](#).

Roof Structure / Cover:

The exterior walls comprise the roof structure and cover.

Floor Structure / Cover:

Wood structure and [subfloor](#) on first and upper floors, or concrete slab on first floor and wood on upper floors.

Interior Finish:

Interior finish will show no appreciable differences from conventional construction of the same quality. (See single family home model descriptions of similar quality grade.)

Plumbing:

Plumbing fixtures and rough-in of a type and number commensurate with the construction quality of the building. (See single family home model descriptions of similar quality grade.)

Heating / Cooling:

[Heat pump](#) or forced air furnace with adequate output and ductwork. Evaporative cooling or air conditioning.

»»» continued on next page »»»»

MODEL 014 - X**DOME HOME****(continued)****Electrical:**

Finished electric of a type and quantity commensurate with construction quality. (See single family home model descriptions of similar quality grade.)

Porches / Patios:

[Porches](#) and [patios](#) are similar in quality of material and workmanship to the residence.

Garages / Carports:

[Garages](#) and [carports](#) are similar in quality of material and workmanship to the residence.

MODEL 014 - X ILLUSTRATIONS



MODEL 014 - X ILLUSTRATIONS



MODEL 015 - X**RAMMED EARTH HOME****Features:**

This residential structure features exterior masonry walls made of a compressed mixture of earth, aggregate, and Portland cement. These walls typically vary from 18 to 36 inches in thickness. Because of the thickness of these walls, the square footage should be determined based on an 8-inch wall thickness. (For wall calculation, refer to listing procedure in [Volume I, Appendix A.](#)) Other than exterior walls, construction techniques for this type of residence will have no appreciable difference from conventional single family residences.

Foundation:

Continuous concrete [perimeter](#).

Exterior Walls:

A solid masonry wall, typically 18 to 36 inches thick, made of a mixture of earth, aggregate, and Portland cement that has been compressed, dried, and covered with an exterior stucco finish. Interior finish may be stucco, drywall, or clear sealer. [Bond beam](#) is included in the cost. Use exterior wall component code [WX \(Rammed earth, residential\)](#).

Roof Structure / Cover:

Prefabricated [trusses](#) with exterior grade plywood or wood sheathing, with metal cover or a [built-up roof](#) cover on Santa Fe style.

Floor Structure / Cover:

Concrete slab on grade. [Vinyl composition tile](#) with carpet and pad floor cover.

Interior Finish:

Interior finish will show no appreciable differences from conventional construction of the same quality. (See single family home model descriptions of similar quality grade.)

»»» continued on next page »»»

MODEL 015 - X**RAMMED EARTH HOME****(continued)****Plumbing:**

Standard plumbing fixtures with rough-in.

Heating / Cooling:[Heat pump](#) or forced air furnace with adequate output and ductwork. [Evaporative cooling](#) or air conditioning.**Electrical:**

Finished electrical with adequate number of outlets and some luminous lighting fixtures in kitchen and bath areas.

Porches / Patios:[Porches](#) and [patios](#) are similar in quality of material and workmanship to the residence.**Garages / Carports:**[Garages](#) and [carports](#) are similar in quality of material and workmanship to the residence.

MODEL 015 - X ILLUSTRATIONS

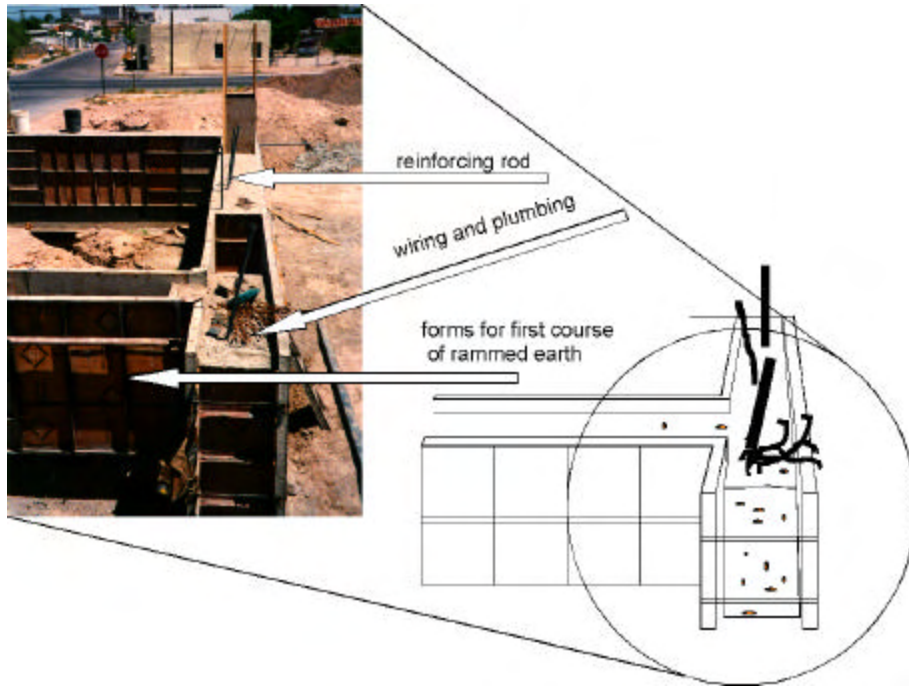

The photos above show the second course of forms in place above the completed first course. Forms are disassembled and reassembled as each course is finished.

MODEL 015 - X ILLUSTRATIONS

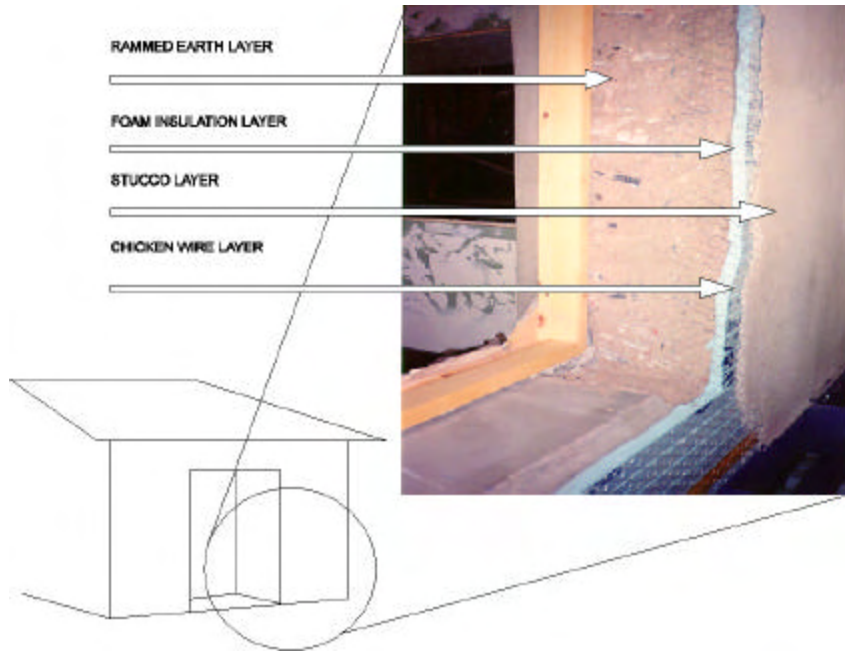

Notice that the two finished rammed earth residences above look very similar to conventional houses. One of the indications that a structure might be adobe or rammed earth is the thickness of the walls, as shown in the photo and diagram at the top of the page.

MODEL 016 - X**EARTH SHELTERED HOME****Features:**

These homes are either constructed into the surface of the earth like a [basement](#), built into the side of a hill, or on grade with the earth mounded around the outside walls. Each technique leaves at least one side open for access and [fenestration](#). These homes are often defined as an alternate style of construction as they utilize soil for [insulation](#) providing a more constant year- round temperature. They are generally found in more rural areas.

Foundation:

Continuous concrete [perimeter](#).

Exterior Walls:

Poured reinforced concrete, precast concrete panels, concrete block, waterproofing, and dirt. Use appropriate basement wall component codes for areas below ground, covered by earth or built into the side of a hill.

Roof Structure / Cover:

Precast concrete plank, reinforced poured in place concrete, or wood joist and [sheathing](#), Styrofoam insulation, waterproofing, dirt.

Floor Structure / Cover:

Concrete on ground or wood [joist](#) and sheathing. [Vinyl composition tile](#) with carpet and pad.

Interior Finish:

Interior finish would be typical of conventional construction although interior partition walls may be [load bearing](#).

Plumbing:

Plumbing fixtures of a type and number commensurate with the construction quality. (See single family home model descriptions of similar quality grade.)

>>>> continued on next page >>>>

MODEL 016 - X**EARTH SHELTERED HOME****(continued)****Heating / Cooling:**

Conventional heating and cooling systems, although passive and active [solar heating systems](#) are more prevalent than in conventional construction.

Electrical:

Finished electrical of a type and quantity commensurate with the construction quality. (See single family home model descriptions of similar quality grade.)

Porches / Patios:

[Porches](#) and [patios](#) are similar in quality of material and workmanship to the residence.

Garages / Carports:

[Garages](#) and [carports](#) are similar in quality of material and workmanship to the residence.

MODEL 016 - X ILLUSTRATIONS

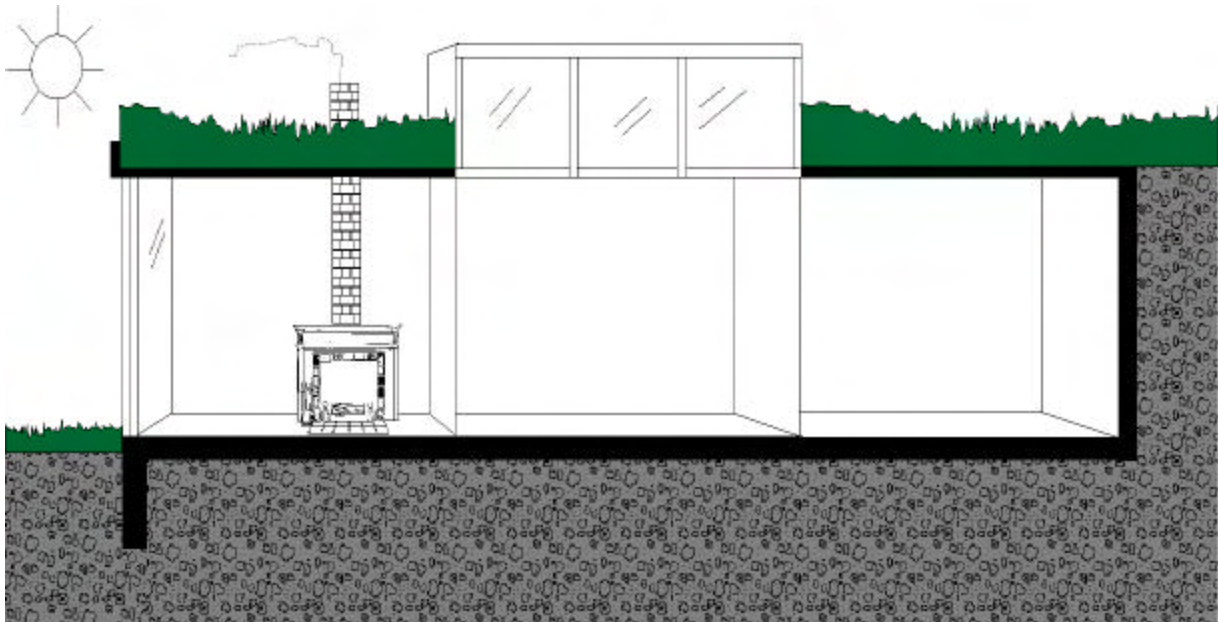
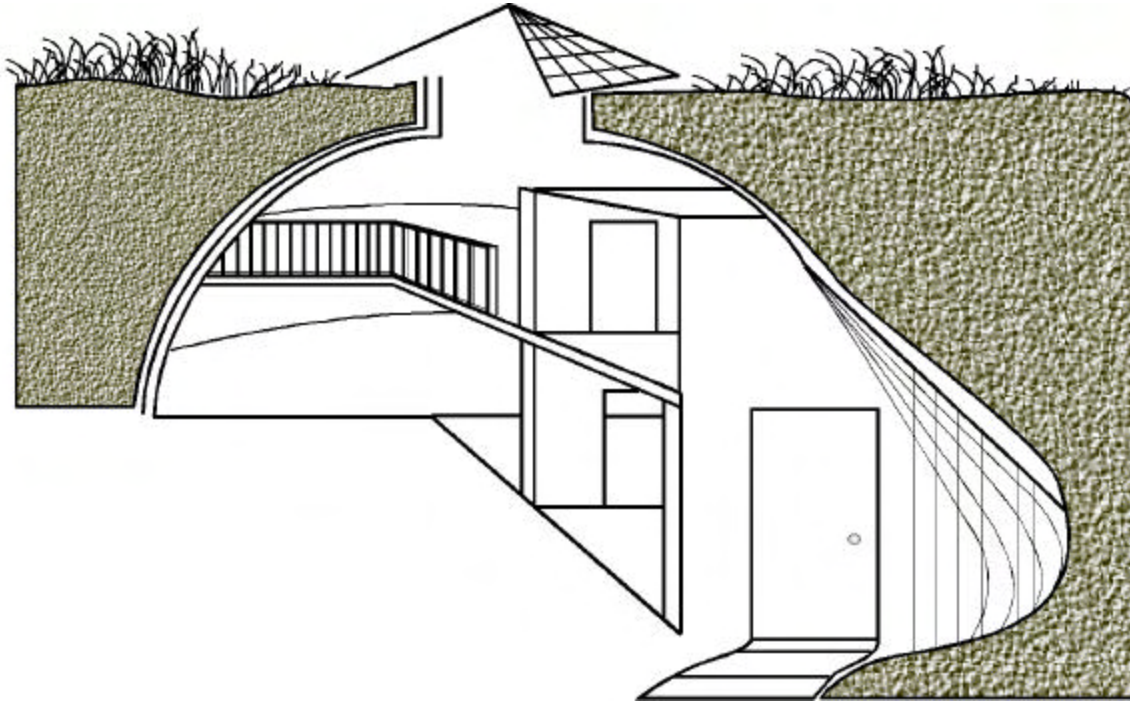

Cutaway views of some typical earth sheltered designs.

MODEL 016 - X ILLUSTRATIONS



MODEL 017 - X**ENVELOPE HOME****Features:**

Envelope homes utilize an exterior wall configuration that creates a double wall on the north and south facing walls. This double wall allows for air to travel between the walls as shown in the drawing. The windows are also doubled: a dual pane window for the outside wall and a dual pane window for the inside wall. The ceiling space is doubled to allow airflow or there is a second floor area that is open at the top of the north and south walls. There is also a [crawl space](#) or [basement](#) area that permits airflow. This basement area may contain heat collectors such as large concrete pillars or large sealed barrels filled with water to retain the heat absorbed from the air passing over them. The south wall of the home will have an enclosed greenhouse area maximizing the heating potential of the sun's rays. The greenhouse also has vented areas in the floor that allows air to circulate completely in the air space created around the home. The heat transfer process is called convection. The drawing shows how the heat generated by the sun in the greenhouse area rises to the highest part of the home where it then begins to cool. As the air cools, it falls down the envelope to the double wall on the north of the home and into the basement area, gradually warming the ground and any solid mass objects. As the heated air rises from the south wall, it creates a void that is filled by the basement air. The air is constantly moving and warming during the day. At night, the airflow is reversed. Shades and operable windows are used to control and vent excess heat during the summer months. The envelope home is an alternate building style meant to increase energy efficiency.

Foundation:

Continuous concrete [perimeter](#).

Exterior Walls:

Exterior wall construction will show no appreciable differences from conventional construction of the same quality.

MODEL 017 - X**ENVELOPE HOME****(continued)**

Roof Structure / Cover: Prefabricated [trusses](#) with exterior grade plywood or wood [sheathing](#) with composition or wood shingle.

Floor Structure / Cover: Wood joist and sheathing. [Vinyl composition tile](#) with carpet and pad.

Interior Finish: Interior finish will show no appreciable differences from conventional construction of the same quality. (See single family home model descriptions of similar quality grade.)

Plumbing: Plumbing fixtures of a type and number commensurate with the construction quality. (See single family home model descriptions of similar quality grade.)

Heating / Cooling: Conventional heating and cooling systems may be needed to supplement solar heating and cooling.

Electrical: Finished electrical of a type and quantity commensurate with the construction quality. (See single family home model descriptions of similar quality grade.)

Porches / Patios: [Porches](#) and [patios](#) are similar in quality of material and workmanship to the residence.

Garages / Carports: [Garages](#) and [carports](#) are similar in quality of material and workmanship to the residence.

MODEL 017 - X ILLUSTRATIONS

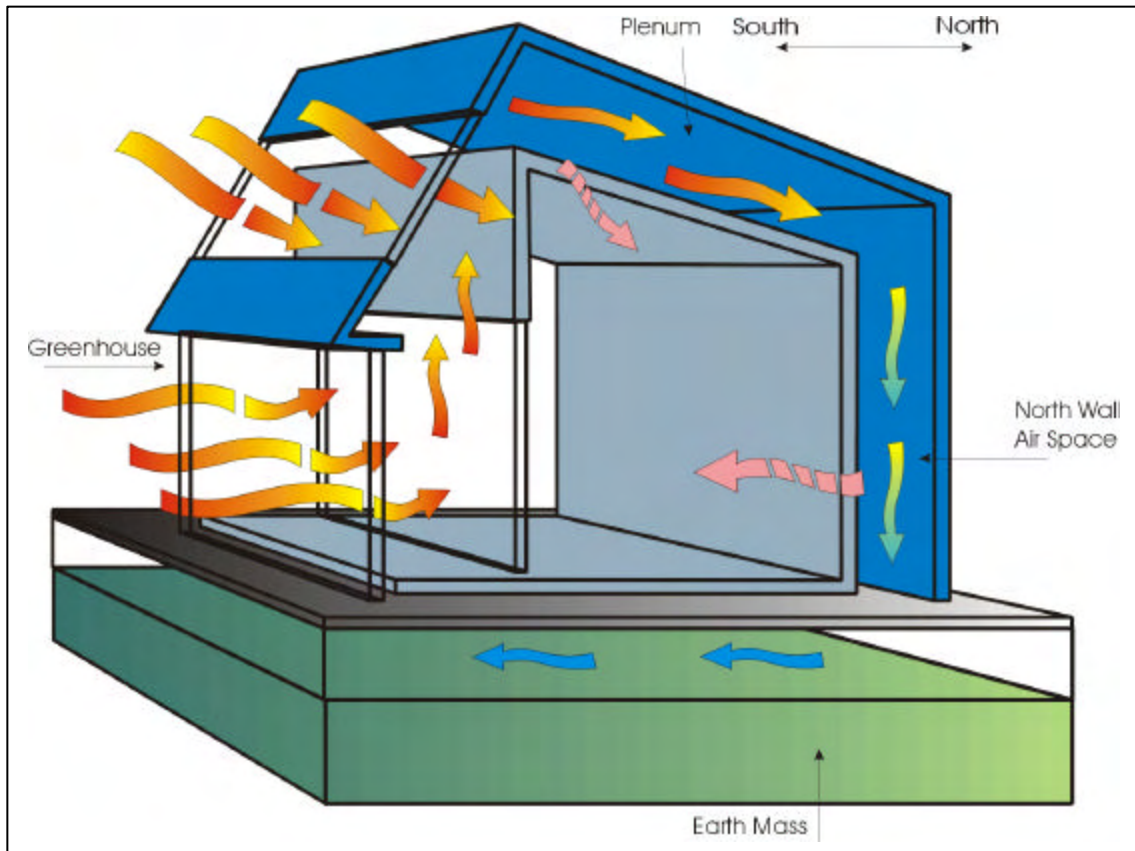

View of an envelope house and some of the terminology associated with this type of construction.

MODEL 018 - X**SPECIALTY HOME****Features:**

Specialty homes are often individually designed and constructed. Standard materials are used throughout. These homes generally meet or exceed the minimum building codes.

Foundation:

Continuous concrete [perimeter](#).

Exterior Walls:

Exterior wall construction may be of straw bales, rubber tires, or any other specialty material such as Styrofoam composition block. Other than exterior walls, construction techniques for this type of residence will have no appreciable difference from conventional single family residences.

Roof Structure / Cover:

Prefabricated [trusses](#) with exterior grade plywood or wood [sheathing](#) with composition or wood shingle.

Floor Structure / Cover:

Concrete on ground. [Vinyl composition tile](#) with carpet and pad.

Interior Finish:

Interior finish will show no appreciable differences from conventional construction of the same quality. (See single family home model descriptions of similar quality grade.)

Plumbing:

Plumbing fixtures of a type and number commensurate with the construction quality. (See single family home model descriptions of similar quality grade.)

Heating / Cooling:

[Heat pump](#) or forced air furnace with adequate output and ductwork. [Evaporative cooling](#) or air conditioning.

>>>> continued on next page >>>>

MODEL 018 - X**SPECIALTY HOME****(continued)**

Electrical: Finished electrical of a type and quantity commensurate with the construction quality. (See single family home model descriptions of similar quality grade.)

Porches / Patios: [Porches](#) and [patios](#) are similar in quality of material and workmanship to the residence.

Garages / Carports: [Garages](#) and [carports](#) are similar in quality of material and workmanship to the residence.

MODEL 018 - X ILLUSTRATIONS



Several examples of Yurt houses. The manufactured yurts have a preformed lexan dome and treated, canvas-like outer "skin". The owner-built example has nearly one story below ground level.

A house under construction using a Styrofoam composite block. There are a number of varieties of this block on the market.

MODEL 018 - X ILLUSTRATIONS

Some examples of hay bale construction. Notice that the finished improvements are very similar to conventionally constructed housing.

MODEL 019 - X**HILLSIDE HOME****Features:**

A single family dwelling where the lowest level of the structure may be partially below grade due to the topography of the site. Structures on extreme grades may have multiple levels partially below grade. This model may be used as an optional substitute for the 010-x model if the assessor determines a need to identify hillside homes as a separate group. The 019-x model will produce an identical cost value to the 010-x model.

Foundation:

Concrete [perimeter](#) footing and stem wall with continuous foundation or [piers](#) under interior bearing walls.

Exterior Walls:

Wood frame, frame or block stucco, concrete block or reinforced concrete with [fenestration](#) and ornamentation commensurate with the quality of the building.

Roof Structure / Cover:

Prefabricated [trusses](#) with exterior grade plywood or wood sheathing. Roof cover is usually composition shingle, concrete tile, or wood shake.

Floor Structure / Cover:

Concrete slab on first level and wood joist and [subfloor](#) on upper levels.

Interior Finish:

Interior finish will show no appreciable difference from 010's of the same quality. (See single family home model descriptions of similar quality grade.)

Plumbing:

Plumbing fixtures and rough-in of a type and number commensurate with the construction quality of the building.

Heating / Cooling:

Higher quality units will have ducted forced air furnaces with air conditioning or [heat pumps](#), while lower quality will have [wall furnaces](#) and [evaporative cooling](#).

Electrical:

Finished electrical with adequate number of outlets and some luminous lighting fixtures in kitchen and bath areas.

MODEL 019 - X**HILLSIDE HOME****(continued)****Porches / Patios:**

[Porches](#), [patios](#), and exterior [balconies](#) are similar in quality to that of the residence.

Garages / Carports:

[Garages](#) and [carports](#) are similar in quality to that of the residence.

MODEL 019 - X ILLUSTRATIONS



MODEL 019 - X ILLUSTRATIONS



MODEL 020 - X**SINGLE FAMILY RESIDENCE MULTI-STORY****Features:**

A multi-story single family residence, commonly referred to as 1½ story, 2 story, 2½ story, etc., where the residence generally has the sleeping areas on the upper levels. This model may be used as an optional substitute for the 010-x model if the assessor determines a need to identify multi-story homes as a separate group. The 020-x model will produce an identical cost value to the 010-x model.

Foundation:

Concrete [perimeter](#) footing and stem wall with continuous foundation or [piers](#) under interior bearing walls.

Exterior Walls:

Wood frame, frame or block stucco, concrete block or reinforced concrete with [fenestration](#) and ornamentation commensurate with the quality of the building.

Roof Structure / Cover:

Prefabricated [trusses](#) with exterior grade plywood or wood [sheathing](#). Roof cover is usually composition shingle, concrete tile, or wood shake.

Floor Structure / Cover:

Concrete slab on first level and wood joist and [subfloor](#) on upper levels.

Interior Finish:

Interior finish will show no appreciable difference from 010's of the same quality. (See single family home model descriptions of similar quality grade.)

Plumbing:

Plumbing fixtures and rough-in of a type and number commensurate with the construction quality of the building.

Heating / Cooling:

Higher quality units will have ducted forced air furnaces with air conditioning or [heat pumps](#), while lower quality will have [wall furnaces](#) and [evaporative cooling](#).

Electrical:

Finished electrical with adequate number of outlets and some luminous lighting fixtures in kitchen and bath areas.

continued on next page

MODEL 020 - X SINGLE FAMILY RESIDENCE MULTI-STORY (continued)

Porches / Patios: [Porches](#), [patios](#), and exterior [balconies](#) are similar in quality to that of the residence.

Garages / Carports: [Garages](#) and [carports](#) are similar in quality to that of the residence.

MODEL 020 - X ILLUSTRATIONS



MODEL 020 - X ILLUSTRATIONS



MODEL 028 - X**FACTORY / SITE BUILT HOME****Features:**

This model is to be used when a mobile home is completely absorbed by its surrounding addition to the point that the mobile home has lost its identity. The use of this model is subject to the following conditions.

"The mobile home (usually a single-wide) has been completely absorbed by its surrounding addition(s), to the point that the mobile home has lost its identity. When a mobile home has been completely assimilated into the total structure, and the owner has either obtained a dismantling permit from the Department of Transportation, or has recorded an Affidavit of Affixture, the mobile home should then be valued as a part of the structure and not as a mobile home. The County Assessor should value the mobile home portion and the surrounding addition(s) using the same techniques as those that are applicable to any other conventionally-constructed improvement. If the owner has not obtained a Dismantling Permit, or has not recorded an Affidavit of Affixture, the structure (less the square footage of the mobile home) shall be valued separately from the mobile home. In this instance, the mobile home must be listed as personal property." ADOR Personal Property Manual, page 7.20.

The 028x model produces an identical cost and uses the same depreciation table as the 010x, (Single Family Home) model.

Foundation:

Concrete [perimeter](#) footing and stem wall with continuous foundation or [piers](#) under interior [bearing walls](#).

Exterior Walls:

Wood frame, frame or block stucco, concrete block or reinforced concrete with [fenestration](#) and ornamentation commensurate with the quality of the building.

Roof Structure / Cover:

Prefabricated [trusses](#) with exterior grade plywood or wood sheathing. Roof cover is usually composition shingle, concrete tile, or wood shake.

Floor Structure / Cover:

Concrete slab and /or wood [joist](#) on first level and wood joist and [subfloor](#) on upper levels.

Interior Finish:

Interior finish will show no appreciable difference from 010's of the same quality. (See single family home model descriptions of similar quality grade.)

continued on next page

MODEL 028 - X	FACTORY / SITE BUILT HOME	(continued)
Plumbing:	Plumbing fixtures and rough-in of a type and number commensurate with the construction quality of the building.	
Heating / Cooling:	Higher quality units will have ducted forced air furnaces with air conditioning or heat pumps , while lower quality will have wall furnaces and evaporative cooling .	
Electrical:	Finished electrical with adequate number of outlets and some luminous lighting fixtures in kitchen and bath areas.	
Porches / Patios:	Porches , patios , and exterior balconies are similar in quality to that of the residence.	
Garages / Carports:	Garages and carports are similar in quality to that of the residence.	

MODEL 028x - 1 ILLUSTRATIONS



MODEL 028x - 1 ILLUSTRATIONS



MODEL 032 - X**DUPLEX****Features:**

One structure is designed to contain 2 single family residences. The living units are separated by a **common wall**. However, in some instances, these structures may be 2-story, 2-family buildings that share a common floor and ceiling rather than a common wall. Each unit will have an individual exterior entry.

Foundation:

Concrete **perimeter** footing and stem wall with continuous foundation or **piers** under interior **bearing walls**.

Exterior Walls:

Wood frame, concrete block, frame stucco, or block stucco with **fenestration** and ornamentation commensurate with the quality of the building.

Roof Structure / Cover:

Prefabricated **trusses** with exterior grade plywood or wood **sheathing**. Roof cover is usually composition shingle, concrete tile, or wood shake.

Floor Structure / Cover:

Wood floor **joists** and **subfloor** on first and upper floors, or concrete slab on grade and wood joists on upper floors.

Interior Finish:

Interior finish will show no appreciable differences from conventional construction of the same quality. (See single family home model descriptions of similar quality grade.)

Plumbing:

Plumbing fixtures and rough-in of a type and number commensurate with the construction quality of the building.

Heating / Cooling:

Higher quality units will have ducted forced air furnaces with air conditioning or **heat pumps**, while lower quality will have **wall furnaces** and **evaporative cooling**.

>>>> continued on next page >>>>

MODEL 032 - X**DUPLEX****(continued)****Electrical:**

Finished electrical with adequate number of outlets and some luminous lighting fixtures in kitchen and bath areas.

Porches / Patios:

[Porches](#), [patios](#), and exterior [balconies](#) are similar in quality to that of the residence.

Garages / Carports:

[Garages](#) and [carports](#) are similar in quality to that of the residence.

MODEL 032 - X ILLUSTRATIONS



MODEL 032 - X ILLUSTRATIONS



MODEL 032 - X ILLUSTRATIONS



MODEL 032 - X ILLUSTRATIONS



MODEL 033 - X**TRIPLEX**

- Features:** One structure is designed to contain 3 single family residences. Typically, each unit will have an individual exterior entry.
- Foundation:** Concrete [perimeter](#) footing and stem wall with continuous foundation or [piers](#) under interior [bearing walls](#).
- Exterior Walls:** Wood frame, concrete block, frame stucco, or block stucco with [fenestration](#) and ornamentation commensurate with the quality of the building.
- Roof Structure / Cover:** Prefabricated [trusses](#) with exterior grade plywood or wood sheathing. Roof cover is usually composition shingle, concrete tile, or wood shake.
- Floor Structure / Cover:** Wood floor [joists](#) and [subfloor](#) on first and upper floors, or concrete slab on grade and wood joists on upper floors.
- Interior Finish:** Interior finish will show no appreciable differences from conventional construction of the same quality. (See single family home model descriptions of similar quality grade.)
- Plumbing:** Plumbing fixtures and rough-in of a type and number commensurate with the construction quality of the building.
- Heating / Cooling:** Higher quality units will have ducted forced air furnaces with air conditioning or [heat pumps](#), while lower quality will have [wall furnaces](#) and [evaporative cooling](#).
- Electrical:** Finished electrical with adequate number of outlets and some luminous lighting fixtures in kitchen and bath areas.

»»» continued on next page »»»

MODEL 033 - X**TRIPLEX****(continued)****Porches / Patios:**

Porches, patios, and exterior balconies are similar in quality to that of the residence.

Garages / Carports:

Garages and carports are similar in quality to that of the residence.

MODEL 033 - X ILLUSTRATIONS



MODEL 033 - X ILLUSTRATIONS



MODEL 034 - X**FOURPLEX****Features:**

One structure is designed to contain 4 single family residences. Typically, units will all be at ground level or 2 at ground level and 2 above. Each unit will have an individual exterior entry.

Foundation:

Concrete [perimeter](#) footing and stem wall with continuous foundation or [piers](#) under interior bearing walls.

Exterior Walls:

Wood frame, concrete block, frame stucco, or block stucco with [fenestration](#) and ornamentation commensurate with the quality of the building.

Roof Structure / Cover:

Prefabricated [trusses](#) with exterior grade plywood or wood [sheathing](#). Roof cover is usually composition shingle, concrete tile, or wood shake.

Floor Structure / Cover:

Wood floor [joists](#) and [subfloor](#) on first and upper floors, or concrete slab on grade and wood joists on upper floors.

Interior Finish:

Interior finish will show no appreciable differences from conventional construction of the same quality. (See single family home model descriptions of similar quality grade.)

Plumbing:

Plumbing fixtures and rough-in of a type and number commensurate with the construction quality of the building.

Heating / Cooling:

Higher quality units will have ducted forced air furnaces with air conditioning or [heat pumps](#), while lower quality will have [wall furnaces](#) and [evaporative cooling](#).

>>>> continued on next page >>>>

MODEL 034 - X**FOURPLEX****(continued)**

Electrical: Finished electrical with adequate number of outlets and some luminous lighting fixtures in kitchen and bath areas.

Porches / Patios: [Porches](#), [patios](#), and exterior [balconies](#) are similar in quality to that of the residence.

Garages / Carports: [Garages](#) and [carports](#) are similar in quality to that of the residence.

MODEL 034 - X ILLUSTRATIONS



MODEL 034 - X ILLUSTRATIONS



MODEL 070 - X
MODEL 071 - X
MODEL 072 - X

CONDOMINIUM / TOWNHOUSE (ENTIRE BUILDING)
CONDOMINIUM / TOWNHOUSE (INSIDE UNIT)
CONDOMINIUM / TOWNHOUSE (END UNIT)

Features:

Townhouses are a number of single family residences attached in a row. An inside unit is defined as one which is constructed between other townhouse units and having two [common sidewalls](#). An end unit is defined as one which is constructed at the end of a row of townhouse units and having one exposed side. See [Appendix A](#) for condominium listing techniques.

Foundation:

Concrete [perimeter](#) footing and stem wall with continuous foundation or [piers](#) under interior [bearing walls](#)

Exterior Walls:

Wood frame, concrete block, frame stucco, or block stucco with [fenestration](#) and ornamentation commensurate with the quality of the building.

Roof Structure / Cover:

Prefabricated [trusses](#) with exterior grade plywood or wood [sheathing](#). Roof cover is usually composition shingle, concrete tile, or wood shake.

Floor Structure / Cover:

Wood floor [joists](#) and [subfloor](#) on first and upper floors, or concrete slab on grade and wood joists on upper floors.

Interior Finish:

Interior finish will show no appreciable differences from conventional construction of the same quality. (See single family home model descriptions of similar quality grade.)

Plumbing:

Plumbing fixtures and rough-in of a type and number commensurate with the construction quality of the building.

>>>> continued on next page >>>>

MODEL 070 - X CONDOMINIUM / TOWNHOUSE (ENTIRE BUILDING) (continued)
MODEL 071 - X CONDOMINIUM / TOWNHOUSE (INSIDE UNIT)
MODEL 072 - X CONDOMINIUM / TOWNHOUSE (END UNIT)

Heating / Cooling: [Heat pump](#) or forced air furnace and air conditioning with adequate output and ductwork.

Electrical: Finished electrical with adequate number of outlets and some luminous lighting fixtures in kitchen and bath areas.

Porches / Patios: [Porches](#), [patios](#), and exterior [balconies](#) are similar in quality to that of the residence.

Garages / Carports: [Garages](#) and [carports](#) are similar in quality to that of the residence.

MODEL 070 - X, 071 - X, 072 - X ILLUSTRATIONS



MODEL 070 - X, 071 - X, 072 - X ILLUSTRATIONS



MODEL 885 - X**RECREATIONAL VEHICLE SUPPORT BUILDING****Features:**

Recreational Vehicle Support Buildings are typically individually designed and constructed. These structures will usually include toilet, bath and/or laundry facilities. Standard residential materials are used throughout. These structures meet or exceed minimum building codes. This model will produce identical component costs and depreciation as other residential site-built models of the same quality and age. This model is **not** available in the Square Foot System.

Foundation:

Continuous concrete [perimeter](#).

Exterior Walls:

Walls for this type of structure will have no appreciable difference from classes C, D and S conventional residential construction.

Roof Structure / Cover:

Prefabricated [trusses](#) with exterior grade plywood or wood sheathing with built-up, composition or tile cover.

Floor Structure / Cover:

Concrete on ground. [vinyl composition tile](#), ceramic tile and/or carpet and pad.

Interior Finish:

Interior finish will show no appreciable differences from conventional residential construction of the same quality.

Plumbing:

Plumbing fixtures of a type commensurate with the construction quality.

Heating / Cooling:

If present, [heat pump](#) or forced air furnace. [Evaporative cooling](#) or air conditioning for cooling.

continued on next page

MODEL 885 - X**RECREATIONAL VEHICLE SUPPORT BUILDING (continued)**

- Electrical:** Finished electrical of a type commensurate with the construction quality.
- Porches / Patios:** [Porches](#) and [patios](#) are similar in quality of material and workmanship to the building.
- Garages / Carports:** [Garages](#) and [carports](#) are similar in quality of material and workmanship to the building.

MODEL 885 - X ILLUSTRATIONS



MODEL 885 - X ILLUSTRATIONS



MODEL 035 - X APARTMENT 3 STORIES OR LESS

These are multiple residences of three or fewer stories in which each unit has a kitchen and bath. They are designed for other than transient occupancy (permanent or semi-permanent).

- Lower quality units will have low cost construction and fixtures, minimal design, and limited cabinet and closet space. They may contain one or two bedrooms or studio units or any combination thereof.
- Average quality units will have sufficient cabinet and closet space, average quality construction and fixtures, and may contain one to three bedroom or studio units or combinations. These may also contain elevators, lobbies, and interior entrance doors.
- Good quality units will have adequate cabinet and closet space, good quality construction and fixtures, and may contain one to three or more bedroom units. They may include multiple bathrooms, high quality kitchens, and security intercoms and/or secured parking
- High quality units will have excellent fixtures and high quality construction. They will have deluxe kitchens, possibly containing built-in microwaves and/or convection ovens, multiple baths, and abundant cabinet and closet space. They may also include intercoms, security gates, and secured parking. These units may have one, two, three or more bedrooms, or any combination thereof.

Note: Building adds such as canopies, balconies, exterior stairs, and [mezzanines](#) may not always have the same rank as the model quality indicator. These adds must be ranked according to the information in the alphabetized component descriptions in the manual.

TYPE	EXTERIOR WALLS	INTERIOR FINISH	PLUMBING / ELECTRICAL	HEATING / COOLING
Excellent	Face brick, stone veneer, good wood or steel frame, best stucco or siding, or concrete/metal panels, ample fenestration, excellent trim, best roof structure/cover	Good plaster, drywall, paint, paneling, fine detail, hardwood , carpet, ceramic tile	High quality fixtures, many outlets, intercoms, high quality plumbing fixtures with ample number of baths	Heat Pump
Good	Good brick, stucco on block, good stucco or siding, some brick or stone trim, roof structure and cover	Good plaster or drywall, hardwood , carpet, vinyl tile	Good lighting, adequate outlets, fixtures, good quality plumbing fixtures, adequate number of baths	Package AC
Average	Brick or block, brick veneer, stucco or siding, adequate fenestration, some trim, asphalt shingle or built-up roof, average code construction	Plaster/drywall, paint, hardwood , carpet, vinyl composition	Adequate lighting, average number of outlets, average quality plumbing fixtures	Forced air , AC
Low Cost	Low-cost brick or brick veneer, or block, very plain, or low cost stucco or siding, minimum fenestration	Gypsum board, taped and painted, painted block, low-cost carpet or asphalt tile, drywall partitions	Minimum lighting, plumbing, per code	Wall furnace, room AC, if any

MODEL 035 - X ILLUSTRATIONS



MODEL 035 - X ILLUSTRATIONS



MODEL 035 - X ILLUSTRATIONS



MODEL 035 - X ILLUSTRATIONS



MODEL 036 - X APARTMENT 4 STORIES OR MORE

These are **high rise**, residential multiple dwelling units of four or more stories, each with kitchen facilities. Usually elevators are used/required by code, and these buildings have lobbies, fire escapes, and interior entrance doors.

Note: These high rise structures may be condominiums; however, condominium is a type of ownership, not a type of construction.

- Lower quality units will have low-cost construction and fixtures, very plain design, and limited cabinet and closet space. They may contain one or two bedrooms or studio units or any combination thereof.
- Average quality units will have adequate cabinet and closet space, average quality construction and fixtures, and may contain one to three bedroom or studio units or combinations. Each unit will have cooking, bath, and living area.
- Good quality units will have adequate cabinet and closet space, good quality construction and fixtures, and may contain one to three or more bedroom units. They may include multiple bathrooms, high quality kitchens, and security intercoms and/or secured parking.
- High quality units will have excellent fixtures and high quality construction. They will have deluxe kitchens, possibly containing built-in microwaves and/or convection ovens, multiple baths, and abundant cabinet and closet space. They may also include intercoms, security gates, and secured parking. These units may have one, two, three or more bedrooms, or any combination thereof.

Note: Building adds such as canopies, balconies, exterior stairs, and mezzanines may not always have the same rank as the model quality indicator. These adds must be ranked according to the information in the alphabetized component descriptions in the manual.

TYPE	EXTERIOR / WALLS	INTERIOR FINISH	PLUMBING/ELECTRICAL	HEATING/COOLING
Excellent	Best metal or stone, heat absorbent, or double glazing, or brick, metal and glass panels, individual design. Depending on class may also have face brick or stone veneer, best stucco or siding with brick or stone trim	Fine interior detail, carpet, ceramic, some vinyl and fine hardwood , may have paneling, good plaster, paper	High quality fixtures, many outlets, intercoms, high quality plumbing fixtures with one bath per bedroom	Zoned heat and AC
Good	Face brick, limestone, metal, or concrete and glass panels or good stucco or siding with ornamentation. Depending on class, may also have mill type construction with heavy brick walls, trusses, good sash or best insulated sandwich walls, good fenestration, good frame	Good interior detail, carpet or hardwood , sheet vinyl or ceramic tile, or good drywall or plaster	Good lighting, adequate outlets, fixtures, good quality plumbing fixtures, adequate number of baths	Zoned heat and AC or heat pump
Average	Little trim, brick, block, metal or concrete and glass. Depending on class, could have mill type construction, wood trusses, brick and block, or frame and stucco, little trim, or sandwich walls with minimal fenestration	Drywall or plaster, average carpet and vinyl composition, or hardwood floors. Average cabinetry and finish	Adequate lighting, average number of outlets, average quality plumbing fixtures	Heat pump, package heating / AC
Low Cost	Very plain, brick or block, low-cost concrete panels, minimal fenestration, or low-cost siding or stucco	Drywall, sprayed or painted ceilings, very plain, asphalt tile, low-cost carpet	Minimum uniform code, one bath per unit	Hot water heat , room AC, or thru-wall heat pump

MODEL 036- X ILLUSTRATIONS



MODEL 036 - X ILLUSTRATIONS



MODEL 037 - X RETIREMENT APARTMENTS

These are designed to provide congregate housing for the elderly. Typically, these structures are mid-to [high-rise](#), three or more stories, and consist of one, two, or three room suites with limited individual kitchens, and common kitchen and dining areas. Other features include lounges, nursing and therapy rooms, exercise rooms, multipurpose rooms, etc. May include extra plumbing fixtures, wheelchair access, and accessories. Structural features may also include a secured entrance lobby, gift shops, and snack bars.

Do not add [storefront](#). This model may be associated with a nursing care building ([214x](#)). If combined in the same building, sectionalize or make appropriate interior component overrides, whichever is applicable.

- Lower quality units will have low-cost construction and fixtures, very plain design, and low-cost cabinets with little closet space.
- Average quality units will have adequate cabinet and closet space and average quality construction and fixtures.
- Good quality units will have adequate cabinet and closet space, good quality construction and fixtures.
- High quality units will have excellent fixtures and high quality construction. They will have deluxe kitchens, and abundant cabinet and closet space. They may also include intercoms, security gates, and secured parking.

Note: Building adds such as canopies, balconies, pools and spas, elevators, exterior stairs, and mezzanines may not always have the same rank as the model quality indicator. These adds must be ranked according to the information in the alphabetized component descriptions in the manual.

TYPE	EXTERIOR WALLS	INTERIOR FINISH	PLUMBING / ELECTRICAL	HEATING / COOLING
Excellent	Face brick, concrete/metal panels, stone veneer, best stucco or siding, brick and or stone trim, good roof structure, cover	Good plaster, paper, paneling, good detail, hardwood , carpet	Good lighting, many outlets, some special plumbing fixtures	Zoned heat and AC
Good	Good brick/stucco on block, or stucco and siding, some brick or stone trim. Good roof structure and roofing, good fenestration. Depending on class, may be good sandwich panels on pre-engineered frame	Good plaster or drywall, painted, hardwood , carpet or vinyl composition,	Good lighting, plumbing fixtures, some extras, emergency call system	Package AC
Average	Brick or block, some trim, average stucco or siding, or average sandwich panels, adequate fenestration, code construction, standard sash, asphalt shingle or built up roof	Plaster/drywall, hardwood , carpet, vinyl composition	Adequate lighting, average number of outlets, few extras and handicap units	Heat pump, AC
Low Cost	Low cost stucco or siding, very plain, minimum fenestration	Drywall and paint, asphalt tile and low-cost carpet	Minimum lighting, plumbing per code	Electric baseboard heat , room AC

MODEL 037 - X ILLUSTRATIONS



MODEL 037 - X ILLUSTRATIONS



MODEL 038 - X ASSISTED LIVING APARTMENTS(LOW RISE)

These are three stories or less where each studio, one or two bedroom suites have limited individual kitchen facilities and a mix of common support areas associated with congregate housing for the elderly. The better qualities will have good lounges, craft and game areas, beauty parlor and therapy rooms. They also have plaster, paneling, good detailing in molding and trim and high cost floor finishes.

The structures commonly are solid masonry or wood frame walls, classes C and D: for mid-rise classes A or B, use model [037x - Retirement Apartments](#). Some of the special refinements found include task lighting, railings, intercoms, television jacks and antennas, and emergency call systems.

The following are **not** included in the costs: built-in appliances, furnishings and kitchen, laundry, therapy or recreation equipment.

Do not add [storefront](#). This model may be associated with a nursing care building ([214x](#)). If combined in the same building, sectionalize or make appropriate interior component overrides, whichever is applicable.

- Lower quality units will have low-cost construction and fixtures, very plain design, and low-cost cabinets with little closet space.
- Average quality units will have adequate cabinet and closet space and average quality construction and fixtures.
- Good quality units will have adequate cabinet and closet space, good quality construction and fixtures.
- High quality units will have excellent fixtures and high quality construction. They will have deluxe kitchens, and abundant cabinet and closet space. They may also include intercoms, security gates, and secured parking.

Note: Building adds such as canopies, balconies, pools and spas, elevators, exterior stairs, and mezzanines may not always have the same rank as the model quality indicator. These adds must be ranked according to the information in the alphabetized component descriptions in the manual.

TYPE	EXTERIOR WALLS	INTERIOR FINISH	PLUMBING / ELECTRICAL	HEATING/COOLING
Excellent	Face brick, stone veneer, best stucco or siding, good roof structure and roofing	Good plaster, paper, paneling, good detail, some special care	Good lighting, alarm system, some special plumbing fixtures.	Warm and cool air
Good	Good brick, ,stucco siding, or good sandwich panels , good trim, good roofing	Good plaster, drywall, painted hardwood , gypsum board, carpet, vinyl	Good lighting/plumbing, some extras, emergency calls system	Heat pump system
Average	Block, brick, brick veneer, or stucco siding, some trim, average code construction	Plaster/drywall, hardwood , carpet, vinyl composition	Adequate lighting/plumbing, few extra activity facilities	Package heat / AC
Fair	Block, brick, brick veneer, stucco or siding, standard sash, asphalt shingles or build-up rock	Plaster or drywall, hardwood , carpet, vinyl composition tile	Adequate lighting and plumbing, alarm, minimum extra facilities	Forced air
Low Cost	Low-cost stucco or siding, very plain, minimum fenestration	Drywall and paint, asphalt tile and low-cost carpet, minimum detail	Minimum lighting/plumbing, call system, per code	Individual thru wall heat pumps

MODEL 038 - X ILLUSTRATIONS



MODEL 038 - X ILLUSTRATIONS



MODEL 041 - X HOTEL (Obsolete in the future)

This model will become obsolete in the future. List new improvements and change existing listings to one of the following models:

- 043x Hotel, Full Service
- 044x Hotel, Limited Service

Multistory buildings designed for transient overnight accommodations with no individual kitchen facilities. Entrance to the rooms is usually from an inside hallway. Where the ground floor is entirely divided into stores and shops, those areas should be listed using the retail store model (111X). Rooms have private baths and sufficient room size to allow more than one person to move about comfortably.

Hotel construction is often extremely difficult to judge from the exterior, and may be a combination of class A and B to accommodate special features such as wide span ballrooms. The quality is primarily found in the interior. Give consideration to the fact that a downtown hotel with smaller rooms may have a great deal more partitioning and plumbing than a vacation hotel with large rooms and miscellaneous areas. Quality ranking for pricing purposes consists not only of the value of items in the building, but also the quantity of those items. Thus the interior quality of support facilities such as lounges, restaurants, meeting rooms, etc., will be largely dependent on the size of those facilities as much as the quality of the components. Further, the size of those support facilities is largely dependent on the size and capacity of the entire hotel facility, rather than the quality of the improvements.

- Lower quality buildings will have low-cost construction and fixtures, very plain design, a small lobby, and minimal ancillary facilities.
- Average quality units will have average quality materials and workmanship with modest decoration and fixtures. Lobby with centralized access to hallways and rooms, elevators, and average size support facilities such as lounges, meeting rooms, and restaurants.
- Good quality units will have good quality materials and workmanship, highly decorated public facilities of above average capacity.
- High quality units will have high quality features, materials, and workmanship, inside and out. Expansive use of high-cost wall coverings and floor finishes in public areas and sleeping areas, and very high capacity public facilities. Other amenities include support rooms with fax/computer rooms, exercise rooms, etc.

Note: Building adds such as canopies, balconies, exterior stairs and mezzanines, may not always have the same rank as the model quality indicator. These adds must be ranked according to the information in the alphabetized component descriptions in the manual.

TYPE	EXTERIOR WALLS	INTERIOR FINISH	PLUMBING / ELECTRICAL	HEATING/COOLING
Excellent	Best metal or stone, heat absorbent or double glazing, best concrete panels, face brick, or stone.	Fine detail and carpet, good plaster, wall coverings, highly decorated public rooms	Best lighting, radio and TV circuits, top quality plumbing	Zoned heat and AC
Good	Face brick, metal or concrete panels, individual design, metal or concrete and glass, good trim and entrance	Good detail, carpeted, plaster or drywall, good lobby and detailing, well decorated public rooms	Good lighting, radio and TV circuits, good plumbing fixtures	Zoned heat and AC
Average	Face brick, metal or concrete panels, stucco on block, or stucco and siding, good trim, some front ornamentation	Typical good transient or motor hotel, few public rooms. Carpeted, plaster or drywall and painted masonry	Lighting, plumbing above code, standard fixtures, all rooms with bath	Zoned heat and AC
Low Cost	Low-cost stucco or siding, brick, concrete block, metal stud panels, synthetic plaster, very plain, minimum ornamentation	Small lobby, some carpet and tile, minimum ancillary facilities, drywall, wood or asphalt tile	Minimum lighting, plumbing per code, few extras	Electric baseboard heat, wall furnace, or individual through-wall heat pumps, room AC

MODEL 041 - X ILLUSTRATIONS



MODEL 041 -X ILLUSTRATIONS



MODEL 042 - X DORMITORY

Student housing with sleeping rooms which include study areas. Buildings usually have a common lounge area and may or may not have a central dining facility.

- Lower quality units will have either a three-fixture bath unit shared by two rooms, or a common multi-fixture facility. Materials and workmanship will be of minimum cost and design.
- Average quality units will have either a three-fixture bath shared by two rooms, or a common multi-fixture facility. Materials and workmanship will be average quality and design.
- Good quality units will have either a three-fixture bath shared by two rooms, or a common multi-fixture facility. Materials and workmanship will be above average quality and design.
- High quality units will have private baths and study areas. Materials and workmanship are excellent quality and design.

These buildings are normally associated with colleges, boarding schools, military, or nursing schools.

TYPE	EXTERIOR WALLS	INTERIOR FINISH	PLUMBING / ELECTRICAL	HEATING/COOLING
Excellent	Stone, best brick, or brick veneer, good metal or concrete panels. Best designs	Soundproofed rooms, carpeting, built-in furniture, fine lounges, good decoration	Tiled baths, good electrical and plumbing	Zoned, package heat and AC
Good	Face brick, brick veneer or best stucco with trim, metal or concrete panels, good ornamentation	Soundproofed rooms, carpeted halls and lounges, good detail, plaster or drywall	Good electrical and plumbing, good baths, may be shared by two rooms	Heat pump
Average	Face brick, metal or concrete panels, stucco on block, or stucco and siding, good trim, some front ornamentation	Drywall or plaster walls and ceiling, or acoustic tile ceiling, vinyl composition, carpeting	Shared baths, average electrical, standard fixtures	Heat pump
Low Cost	Low-cost stucco or siding, brick, concrete block, precast concrete , very plain, minimum ornamentation, simple entrance	Drywall, acoustic tile , vinyl composition tile, acoustic ceilings, minimal finish	Shared baths, painted shower rooms, minimum number and quality of fixtures, standard electrical	Heat pump

MODEL 042 - X ILLUSTRATIONS



MODEL 042 - X ILLUSTRATIONS



MODEL 043 - X HOTEL, FULL SERVICE

These structures are three or more stories high, having multiple sleeping units without individual kitchen facilities. When the ground floor is entirely divided into stores and shops, use model [111x \(Retail Store\)](#) interior overrides for that floor. The quality of the hotel is determined primarily from the interior refinements. The best quality hotels have a large amount of high-cost wall cover and floor finish in the open, public areas. Sleeping rooms also contain high-cost wall cover as part of the interior finish. The size of the support facilities, e.g., restaurants, bars, meeting rooms, etc., is largely dependent on the size and capacity of the facility rather than the quality of the improvement. Lobby, lounges, restaurants, ballrooms, meeting rooms, kitchens, laundry, storage facilities and office areas are commensurate with the building class and quality chosen. For limited service facilities, use model [044x \(Hotel, Limited Service\)](#).

The following are not included in the costs: furniture, fixtures and equipment (such as bars, counters or seating, kitchen equipment, etc)

Use Model [282x \(Recreation Building\)](#) for pool enclosure buildings.

- Lower quality buildings will have low-cost construction and fixtures, very plain design, a small lobby, and minimal ancillary facilities.
- Average quality units will have average quality materials and workmanship with modest decoration and fixtures. Lobby with centralized access to hallways and rooms, elevators, and average size support facilities such as lounges, meeting rooms, and restaurants.
- Good quality units will have good quality materials and workmanship, highly decorated public facilities of above average capacity.
- High quality units will have high quality features, materials, and workmanship, inside and out. Expansive use of high-cost wall coverings and floor finishes in public areas and sleeping areas, and very high capacity public facilities. Other amenities include support rooms with fax/computer rooms, exercise rooms, etc.

Note: Building adds such as canopies, balconies, exterior stairs and mezzanines, may not always have the same rank as the model quality indicator. These adds must be ranked according to the information in the alphabetized component descriptions in the manual.

TYPE	EXTERIOR WALLS	INTERIOR FINISH	PLUMBING / ELECTRICAL	HEATING/COOLING
Excellent	Best metal, concrete panels, stone, heat absorbent or double glazing	Fine detail and carpet, good plaster and wall coverings	Best lighting, radio and TV circuits, top-quality plumbing	Hot & chilled water (zoned)
Good	Face Brick, metal or concrete panels, glass, good trim, individual design	Good detail, carpeted, highly decorated public rooms	Good lighting, radio and TV circuits, good plumbing fixtures	Warm and cool air (zoned)
Average	Face brick, metal or concrete panels, stucco on block, plain exterior.	Typical good transient or average business hotel, adequate public rooms	Lighting/plumbing above code, standard fixtures.	Heat pump system
Low Cost	Brick, concrete block, metal stud panels, synthetic plaster, stucco, or siding	Few public rooms, small coffee shop	Minimum lighting/plumbing	Individual thru wall heat pumps

MODEL 043 - X ILLUSTRATIONS



MODEL 043 - X ILLUSTRATIONS



MODEL 044 - X HOTEL, LIMITED SERVICE

These structures are three or more stories high, having multiple sleeping units and limited common area amenities. Studio and bedroom suites can have limited kitchen facilities for extended stays. The quality of the hotel is determined primarily from the interior refinements. The best quality hotels have some high-cost wall cover and floor finish in the open and public areas, with larger sleeping room suites containing high cost wall cover. Limited service hotels include some lounge or recreation support facilities, lobby, laundry, storage and office space commensurate with the size and quality of the facility. For full service facilities with lounges, restaurants, ballrooms, meeting rooms, etc., use model [043x \(Hotel, Full Service\)](#).

The following are not included in the costs: furniture, fixtures and equipment (such as kitchen appliances, etc.).

Use Model [282x \(Recreation Building\)](#) for pool enclosure buildings.

- Lower quality buildings will have low-cost construction and fixtures, very plain design, a small lobby, and minimal ancillary facilities.
- Average quality units will have average quality materials and workmanship with modest decoration and fixtures. Lobby with centralized access to hallways and rooms, elevators, and average size support facilities such as lounges, meeting rooms, and restaurants.
- Good quality units will have good quality materials and workmanship, highly decorated public facilities of above average capacity.
- High quality units will have high quality features, materials, and workmanship, inside and out. Expansive use of high-cost wall coverings and floor finishes in public areas and sleeping areas, and very high capacity public facilities. Other amenities include support rooms with fax/computer rooms, exercise rooms, etc.

Note: Building adds such as canopies, balconies, exterior stairs and mezzanines, may not always have the same rank as the model quality indicator. These adds must be ranked according to the information in the alphabetized component descriptions in the manual.

TYPE	EXTERIOR WALLS	INTERIOR FINISH	PLUMBING / ELECTRICAL	HEATING/COOLING
Excellent	Best metal, concrete panels, stone, heat absorbent or double glazing	Fine detail and carpet, good plaster and wall coverings	Best lighting, radio and TV circuits, top-quality plumbing	Hot & chilled water (zoned)
Good	Face Brick, metal or concrete panels, glass, good trim, individual design	Typical good commercial or motor hotel, few public rooms	Good lighting, radio and TV circuits, good plumbing fixtures	Warm and cool air (zoned)
Average	Face brick, metal or concrete panels, stucco on block, plain exterior.	Drywall, carpet, minimum suites, no food service	Lighting/plumbing above code, standard fixtures.	Heat pump system
Low Cost	Brick, concrete block, metal stud panels, synthetic plaster, stucco, or siding, little ornamentation, very plain	Small lobby, some carpet and tile, minimum ancillary facilities.	Minimum lighting/plumbing	Individual thru wall heat pumps

MODEL 044 - X ILLUSTRATIONS



MODEL 044 - X ILLUSTRATIONS



MODEL 051 - X MOTELS

These are multiple sleeping units of usually three stories or less, with or without kitchen facilities, designed for transient occupancy. A lobby, coffee shop, and meeting rooms commensurate with the number of units and the quality is included in the costs. Large restaurants, lounges, or manager's living spaces should be sectionalized or interior overrides used, as appropriate.

- Lower quality units will have one bath per unit, design, material and workmanship of low quality, per code, minimal finish.
- Average quality units will have one bath per unit, standard fixtures, low cost materials and design.
- Good quality units will have better quality baths with above average fixtures. Materials and workmanship will be above average quality and design.
- High quality units will have private baths with high quality fixtures and study areas. Materials and workmanship are excellent quality and design.

Kitchens may be added using the [APP](#) (kitchen includes stove/range, vent hood, garbage disposal, dishwasher) component code in conjunction with the [UM](#) (refrigerator) component. Upgrade as appropriate for quality of components.

Adds such as swimming pools, spas, [mezzanines](#), canopies, and exterior stairs may not be of the same rank as the model quality indicator. These must be ranked according to the information in the alphabetized component listing.

TYPE	EXTERIOR WALLS	INTERIOR FINISH	PLUMBING / ELECTRICAL	HEATING/COOLING
Excellent	Stone, best brick, or brick veneer, good metal or concrete panels. highly decorative	Plaster and vinyl finishes, built-in luxury items, good carpet, good support services	Tiled baths, many outlets, good plumbing, high quality fixtures	Through-wall heat pump
Good	Brick and stone trim, large glass areas, typical large chain motel	Plaster, drywall, paint, good carpet, some built-in extras, support services	Good standard plumbing, standard lighting, adequate outlets	Through-wall heat pump
Average	Common brick or block, little ornamentation, commercial style	Painted block, drywall, few extras, carpet and vinyl composition, no food services	Adequate lighting and plumbing, average fixtures	Through-wall heat pump
Low Cost	Concrete block, siding or stucco, residential sash	Minimum finish, very plain	Minimum code, low-cost fixtures	Through-wall heat pump

MODEL 051 - X ILLUSTRATIONS



MODEL 051 - X ILLUSTRATIONS



MODEL 060 - X DAY CARE CENTER

These are child and handicapped care centers and may include nursery or children's hospitals. Style is most often residential than institutional, and facilities may include kitchens, activity rooms, and multiple rest rooms. Better quality units have reception areas, offices, conference rooms, lunchrooms, shower rooms, and classrooms.

- Lower quality units will have minimal design, low quality materials and workmanship, per code.
- Average quality units will have standard fixtures, low-cost materials and workmanship.
- Good quality units will have better quality materials, workmanship and design, and may have other facilities such as reception areas, conference rooms, and lunch facilities as well as classrooms.
- High quality units will have best quality materials, design, and workmanship, and reception areas, changing rooms, shower and lunch facilities as well as classrooms

TYPE	EXTERIOR WALLS	INTERIOR FINISH	PLUMBING / ELECTRICAL	HEATING/COOLING
Excellent	Face brick, glass panels, stone, best siding, top quality, good ornamentation	Plaster, tile pavers, hardwood , carpet	Tiled rest rooms and kitchen, good lighting, extra features	Heat pump
Good	Brick, concrete or metal panels, good stucco or siding, good trim.	Plaster, or drywall, hardwood , vinyl, carpet	Good rest rooms and kitchen, adequate lighting, plumbing	Package heating and cooling
Average	Brick, block, concrete or metal panels or insulated sandwich panels , pre-engineered frame, some trim	Plaster or drywall, acoustic tile , vinyl composition, carpet	Adequate lighting and plumbing, average rest rooms, kitchen	Package heating and cooling
Low Cost	Brick or block, tilt-up, stucco or siding, light steel frame, siding, no trim, very plain	Drywall, paint, asphalt tile	Minimum code, low-cost fixtures	Wall furnace / evaporative cooling

MODEL 060 - X ILLUSTRATIONS



MODEL 060 - X ILLUSTRATIONS



MODEL 102 - X LAUNDRY BUILDING

These units are used to provide shower and/or dressing, or laundry facilities, separately or combined. These are typically found in commercial camp grounds, RV and mobile home parks, residential apartments and Planned Unit Developments' pool and recreation areas. The units are most often similar in quality and construction to the rest of the facility.

- Lower quality units will have minimal design, low quality materials and workmanship, per code.
- Average quality units will have standard fixtures, low cost materials and workmanship.
- Good quality units will have better quality materials, workmanship, and design.
- High quality units will have best quality materials, design, and workmanship.

TYPE	EXTERIOR WALLS	INTERIOR FINISH	PLUMBING / ELECTRICAL	HEATING/COOLING
Excellent	Brick, block, tilt-up , best stucco or siding	Plaster or drywall, ceramic tile	Ample lighting, outlets, and plumbing	Space heaters
Good	Brick, block, stucco or siding.	Plaster or drywall, hardwood , vinyl, carpet	Adequate lighting, outlets, and plumbing	Space heaters
Average	Brick, block, stucco or siding	Plaster or drywall, acoustic tile , vinyl composition, carpet	Adequate lighting and plumbing.	Space heaters
Low Cost	Brick, block, stucco or siding	Acoustic tile , vinyl composition	Minimum code, low-cost fixtures	Space heaters

MODEL 102 - X ILLUSTRATIONS



MODEL 102 - X ILLUSTRATIONS



MODEL 103 - X REST ROOM BUILDING

These structures are freestanding rest room buildings typically found on golf courses, service stations, poolside recreation areas, parks, gardens, etc. Floors are typically concrete slab at grade with coverings ranging from sealer to vinyl or sheet goods. Exteriors may be wood with siding, steel frame, or concrete block, usually insulated. Interior walls are painted drywall or vinyl wallpaper. Fenestration, electrical, plumbing, and fixtures are commensurate with the quality of the building.

- Lower quality units will have minimal design, low quality materials and workmanship, per code.
- Average quality units will have standard fixtures, low-cost materials and workmanship.
- Good quality units will have better quality materials, workmanship, and design.

TYPE	EXTERIOR WALLS	INTERIOR FINISH	PLUMBING / ELECTRICAL	HEATING/COOLING
Good	Brick, decorative block or concrete, good stucco or wood frame, brick veneer	Finished interior, good tile or glazed surfaces, concession area.	Good lighting and plumbing, extra outlets and fixtures	Wall furnace / evaporative cooling
Average	Concrete block bearing walls, low cost stucco or siding	Painted walls, some ceiling finish, sealed concrete	Adequate lighting and plumbing	Wall furnace
Low Cost	Block, low cost stucco or siding, pre-engineered metal panels, finished inside, very plain	Low cost finishes, few partitions	Minimum code	Space heaters

MODEL 103 - X ILLUSTRATIONS



MODEL 103 - X ILLUSTRATIONS



MODEL 104 - X DEPOT

These units are train or bus stations. This model may be associated with a cafeteria or a restaurant (201x or 202x). If combined in the same building, sectionalize or make appropriate interior component overrides, whichever is applicable.

- Lower quality improvements will be very plain, with low-cost materials and minimum or near minimum building code construction.
- Average quality units will have some trim, average quality materials and design.
- Good quality units will have well finished interiors, better facilities, and some ornamentation.
- High quality units will have well finished interiors and exteriors with architectural embellishment. Better facilities such as full service restaurants will also be associated with these units.

TYPE	EXTERIOR WALLS	INTERIOR FINISH	PLUMBING / ELECTRICAL	HEATING/COOLING
Excellent	Stone, best brick, or brick veneer, good entrance, best designs	Best plaster or paneling, highly ornamental ceilings, terrazzo , carpet, or good mineral tile.	Special lighting fixtures, deluxe rest rooms	Package AC
Good	Face brick , brick veneer or concrete, good walls, stucco or siding, ornamentation	Plaster, acoustic plaster , or tile, carpet, plain terrazzo , vinyl	Good lighting and outlets, good rest rooms and fixtures	Package AC
Average	Brick or concrete, stucco or siding, plain front, little ornamentation	Drywall or plaster walls acoustic tile , rubber or vinyl composition tile	Adequate lighting and outlets, small rest rooms	Package AC
Low Cost	Low cost block or brick, concrete panels, plain front, low-cost stucco or siding.	Very plain, acoustic tile , asphalt tile, gypsum board, vinyl composition	Minimum lighting, outlets, and plumbing fixtures	Forced air

MODEL 104 - X ILLUSTRATIONS



MODEL 104 - X ILLUSTRATIONS



MODEL 105 - X GUARDHOUSE

These units are designed as freestanding structures for security personnel, positioned at entrances to apartment or condominium complexes, residential subdivisions, business compounds (often manufacturing), or other secured areas whose access is monitored.

- Lower quality improvements will be very plain, with low-cost materials and minimum or near minimum building code construction.
- Average quality units will have some trim, average quality materials and design.
- Good quality units will have well finished interiors, better facilities, and some ornamentation.
- High quality units will have well finished interiors and exteriors with architectural embellishment.

Note: Adds such as residential or commercial canopies may be input using the appropriate component codes. For plumbing, use the fixture count method ([IB code](#)).

TYPE	EXTERIOR WALLS	INTERIOR FINISH	PLUMBING / ELECTRICAL	HEATING/COOLING
Excellent	Stone, best brick, or brick veneer, good entrance, best designs	Best plaster or paneling, highly ornamental ceilings, terrazzo , carpet, or good mineral tile	Special lighting fixtures, rest rooms	Thru-wall heat pump
Good	Face brick , brick veneer or concrete, good walls, stucco or siding, ornamentation	Plaster, acoustic plaster , or tile, carpet, plain terrazzo , vinyl	Good lighting and outlets, good fixtures	Thru-wall heat pump
Average	Brick or concrete, stucco or siding, plain front, little ornamentation	Drywall or plaster walls, acoustic tile , rubber or vinyl composition tile	Adequate lighting and outlets	Thru-wall heat pump
Low Cost	Low-cost block or brick, concrete panels, plain front, low-cost stucco or siding.	Very plain, acoustic tile , asphalt tile, gypsum board, vinyl composition	Minimum lighting, outlets and fixtures	Wall furnace, window evaporative cooling

MODEL 105 - X ILLUSTRATIONS



MODEL 105 - X ILLUSTRATIONS



MODEL 110 - X LAUNDROMAT - DRY CLEANING PLANT

These structures are built either to house automatic self-service clothes washers, dryers, and solvent cleaning machines or for full service laundry and dry cleaning which includes a typical retail storefront as well as a laundry workspace. Costs include the plumbing, electrical fixtures, and or natural gas hook-ups necessary for operation but not the laundry equipment. Floors are usually concrete slab at grade with numerous floor drains or a drain trough common to the washers. Floor coverings are typically sheet vinyl or composition tile. Ceilings are usually acoustical tile, countertops are laminate. Heating is usually ceiling mounted, forced air with wall mounted air conditioning. Retail space is commensurate with the rest of the improvements.

- Lower quality improvements will be very plain, with little interior partitioning.
- Average quality units will have some trim, average quality materials and design.
- Good quality units will have well finished interiors, better facilities, and some ornamentation.
- High quality units will have well finished interiors and exteriors with some embellishment.

TYPE	EXTERIOR WALLS	INTERIOR FINISH	PLUMBING / ELECTRICAL	HEATING/COOLING
Excellent	Stone, best brick or brick veneer, good entrance, best designs	Best store finish, carpet, ceramic or vinyl tile, standard unfinished work area	Good lighting and outlets, adequate plumbing	Package AC
Good	Face brick, brick veneer or concrete, good walls, stucco or siding, ornamentation	Good store finish, carpet or vinyl, sealed concrete in work area	Good lighting and outlets, good fixtures	Package AC
Average	Brick or concrete, stucco or siding, plain front, little ornamentation	Finished sales area, plain work area	Adequate lighting and outlets	Evaporative cooling
Low Cost	Low-cost block or brick, concrete panels, plain front, low-cost stucco or siding.	Very plain, acoustic tile, vinyl composition in retail area, sealed concrete in work areas	Minimum lighting, outlets and fixtures	Evaporative cooling

MODEL 110 - X ILLUSTRATIONS



MODEL 110 - X ILLUSTRATIONS



MODEL 111 - X RETAIL STORE

These structures are designed primarily for the purpose of displaying merchandise for sale or rent. The buildings are generally freestanding, but may also be in a shopping center that includes strip stores, and suitable for many different types of retail operation.

A wide variety of exterior construction exists, and ranges from masonry block, concrete tilt-up, to frame / stucco or siding, to metal [pre-engineered](#) styles. Roof styles and coverings also vary considerably. Certain uses may combine a locational style and use, such as farm and ranch supply stores that often appear rural or rustic.

Interiors are usually open and plain to allow for changeable displays and customer movement. Office areas, storage areas, and rest rooms have minimal partitioning. Flooring is generally concrete slab at grade, or in older buildings, raised wood floors. Floor coverings range from high-grade ceramic or vinyl tile and carpeting to asphalt or vinyl sheet goods.

Note: Heating, cooling, lighting, and minimal plumbing for rest rooms are functions of the building, and should be included with the building for assessment purposes, not picked up as tenant improvements.

- Lower quality improvements will be very plain, with little or no exterior embellishment, minimal interior partitioning, and low-cost fixtures.
- Average quality units will have some trim, average quality fixtures and design.
- Good quality units will have well finished interiors, better facilities, and some exterior ornamentation.
- High quality units will have well finished interiors, fine display fronts, and special lighting and fixtures.

TYPE	EXTERIOR WALLS	INTERIOR FINISH	PLUMBING / ELECTRICAL	HEATING/COOLING
Excellent	Stone, best brick or brick veneer, best metal, fine display fronts, best designs	Best plaster and paneling, highly ornamental, terrazzo , carpeting, good mineral or ceramic tile	Special lighting fixtures and effects, deluxe rest rooms	Zoned heating and cooling
Good	Brick or concrete, good metal or stone display front, or best stucco, tilt-up on block, sandwich panels	Plaster, acoustic plaster , or tile, carpet, plain terrazzo , vinyl	Good lighting and outlets, good rest rooms and fixtures	Zoned heating and cooling
Average	Brick or concrete, stucco or siding, plain front, little ornamentation	Plaster or drywall, acoustic tile , vinyl composition, little trim	Adequate lighting and outlets, small rest rooms	Package AC
Low Cost	Low-cost block or brick, tilt-up concrete panels, plain front, low-cost stucco or siding.	Very plain, acoustic tile, gypsum board cheap vinyl composition or asphalt tile, few partitions	Minimum lighting, outlets, and plumbing fixtures	Evaporative cooling, forced air

MODEL 111 - X ILLUSTRATIONS



MODEL 111 - X ILLUSTRATIONS



MODEL 111 - X ILLUSTRATIONS

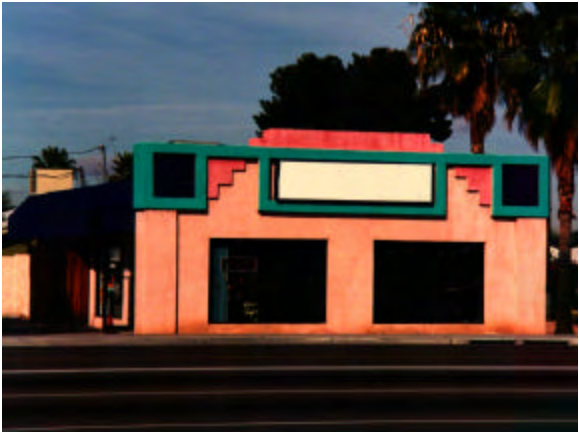

MODEL 111 - X ILLUSTRATIONS



MODEL 112 - X SUPERMARKET

These structures are generally large retail food markets that may also handle other general merchandise items such as housewares, clothing, and gardening supplies. The majority of the floor space is used for merchandise display shelving, with the remainder of the area primarily used for storage, prepackaging areas, walk-in coolers, and freezers.

Exterior construction is usually masonry with concrete foundation at grade and may have concrete [columnar](#) roof supports, and some glass [storefront](#) area. Interior floor covering is usually commercial grade heavy-duty resilient tile or [terrazzo](#). Storage areas usually are sealed concrete with unfinished walls. [Suspended ceilings](#) that house electrical raceways, ducting, and sprinkler systems are also typical.

Note: By using [HA](#) or [HANC](#), the appraiser may or may not include the cost of walk-in cooler boxes from a segregated system listing. The square foot component for this model does not include the cost of walk-in cooler boxes. In a square foot listing, use component [HSFC](#) (built-in coolers) to add the cooler cost. For more information about walk-in cooler boxes, see [Volume I, Appendix A](#).

If a [branch bank](#), [barber/beauty shop](#), or other type of business is present, use the appropriate interior overrides.

- Lower quality improvements will be very plain, with little or no exterior embellishment, minimal interior partitioning, and low-cost fixtures.
- Average quality units will usually be functional buildings with little adornment and plain interior finish.
- Good quality units will have variations from a standard design, with some ornamentation and added interior items.
- High quality units will be individually designed structures with high-cost [storefronts](#) and well-finished interiors.

TYPE	EXTERIOR WALLS	INTERIOR FINISH	PLUMBING / ELECTRICAL	HEATING/COOLING
Excellent	Individual design, heavy frame, best veneer or siding, highly ornamental front	Best plaster and paneling, highly ornamental, terrazzo , carpeting, good mineral or ceramic tile	Special lighting fixtures and effects, deluxe rest rooms	Zoned heating and cooling
Good	Brick, good tilt-up , brick veneer or good siding, good frame and front	Plaster, acoustic plaster , or tile, carpet, plain terrazzo , vinyl	Good lighting and outlets, good rest rooms and fixtures	Zoned heating and cooling
Average	Brick, block, tilt-up , good stucco or siding, sandwich panels , medium steel, glu-lam , or pilasters , some trim	Plaster or drywall, acoustic tile , vinyl composition, little trim	Adequate lighting and outlets, small rest rooms	Package AC
Low Cost	Low cost block or brick, tilt-up concrete panels, low cost stucco or siding.	Very plain, acoustic tile , gypsum board cheap vinyl composition or asphalt tile, few partitions	Minimum lighting, outlets and plumbing fixtures	Evaporative cooling, forced air

MODEL 112 - X ILLUSTRATIONS



MODEL 112 - X ILLUSTRATIONS



MODEL 113 - X CONVENIENCE MARKET

These are small food stores designed for the quick purchase of standard staple items in small quantities. Storage area is relatively small. Sandwiches, coffee, and soft drinks are available at most stores. Many also have fuel pumps with read-out at the counter and one or two public access rest rooms. Exterior construction is typically frame / stucco or masonry on three sides with [storefront](#) entrance.

Note: By using [HA](#) or [HANC](#), the appraiser may or may not include the cost of walk-in cooler boxes from a segregated system listing. The square foot component for this model does not include the cost of walk-in cooler boxes. In a square foot listing, use component [HSFC \(built-in coolers\)](#) to add the cooler cost. For a discussion of [walk-in cooler boxes](#) and [convenience markets with self-service gas](#), see [Volume I, Appendix A](#).

- Lower quality improvements will be very plain with little or no exterior embellishment, minimal interior partitioning, and low-cost fixtures.
- Average quality units will usually be functional buildings with little adornment and plain interior finish.
- Good quality units will have variations from a standard design, with some ornamentation and added interior items.
- High quality units will be individually designed structures with high-cost [storefronts](#) and well-finished interiors.

TYPE	EXTERIOR WALLS	INTERIOR FINISH	PLUMBING / ELECTRICAL	HEATING/COOLING
Excellent	Individual design, best metal panels, highly ornamental exterior	Plaster, acoustic tile terrazzo , carpet or vinyl, good finishes and trim	Special lighting good fixtures and plumbing	Package heat / AC
Good	Brick, best block or stucco, insulated sandwich panels , good storefront and ornamentation	Plaster, good acoustic tile , vinyl tile and carpet	Good lighting and plumbing, rest rooms, standard fixtures	Package heat / AC
Average	Brick, block, tilt-up , good stucco or siding, sandwich panels , medium steel, glu-lam , or pilasters , some trim	Plaster or drywall, acoustic tile , vinyl composition, some snack prep area	Adequate lighting and outlets, small employee rest rooms	Package heat / AC
Low Cost	Low-cost block or brick, tilt-up concrete panels , low-cost stucco or siding.	Very plain, acoustic tile , drywall, few partitions, minimum finish	Minimum code throughout	Evaporative cooling, gas space heaters

MODEL 113 - X ILLUSTRATIONS



MODEL 113 - X ILLUSTRATIONS



MODEL 113 - X ILLUSTRATIONS



MODEL 113 - X ILLUSTRATIONS



MODEL 114 - X STRIP STORE

Typically a freestanding building with at least four individual stores with service or delivery entrances at the rear. Some locations may be in "L" or "U" shaped configuration. Strip stores usually contain small retail or service tenants such as barber or beauty shops, boutiques, travel agents, or ice cream shops. Parcels that contain the strip store may or may not contain an anchor tenant such as a supermarket or discount store. If present, the anchor tenant should be listed separately using the appropriate model.

Exterior construction is typically masonry block/stucco back and sides with [storefront](#) faces, although frame/stucco walls are also common. Interiors are a mix of occupancies (see [Volume I, Section 3 for Shopping Center Tenant Mix](#)). Interior common walls between stores are often movable to allow flexibility of rental space.

Note: Heating, cooling, lighting, and minimal plumbing for rest rooms are functions of the building, and should be included with the building for assessment purposes, not picked up as tenant improvements.

- Lower quality improvements will be very plain, with little or no exterior embellishment, minimal interior partitioning, and low-cost fixtures.
- Average quality units will usually be functional buildings with little adornment and plain interior finish.
- Good quality units will have variations from a standard design, with some ornamentation and added interior items.
- High quality units will be individually designed structures with high-cost [storefronts](#) and well-finished interiors.

TYPE	EXTERIOR WALLS	INTERIOR FINISH	PLUMBING / ELECTRICAL	HEATING/COOLING
Excellent	Individual design, best metal panels, best stucco, highly ornamental exterior	Acoustic tile, terrazzo, carpet or vinyl, good finishes and trim	Special lighting, good fixtures and plumbing	Package heat / AC
Good	Brick, good block or stucco, insulated sandwich panels, good storefront and ornamentation	Good acoustic tile, vinyl tile, and carpet	Good lighting and plumbing, rest rooms, standard fixtures	Package heat / AC
Average	Brick, block, tilt-up, stucco or siding, sandwich panels, medium steel, glu-lam, or pilasters, some trim	Plaster or drywall, acoustic tile, vinyl composition, average finish	Adequate lighting and outlets, small employee rest rooms	Package heat / AC
Low Cost	Low-cost block or brick, tilt-up concrete panels, low-cost stucco or siding.	Very plain, acoustic tile, drywall, few partitions, minimum finish	Minimum code throughout	Evaporative cooling, space heaters

MODEL 114 - X ILLUSTRATIONS



MODEL 114 - X ILLUSTRATIONS



MODEL 115 - X VEHICLE SALES

These are sales showrooms for automobile, farm implement, or boat dealerships. Display areas usually have [storefronts](#), with office, storage, and sales cubicles adjacent.

Typical exterior is masonry, either concrete block or [tilt-up walls](#). Interior is usually large and open, and may have [mezzanine](#) office or storage. Interior finish is often plaster or drywall with [suspended ceilings](#) and lighting similar to store and office lighting, with some better quality improvements having special display spot lighting. Flooring is composition tile or [terrazzo](#) with some carpet in office and sales areas.

Plumbing and rest rooms are adequate to serve sales people and customers, with higher quality showrooms having lounge or kitchen facilities.

- Lower quality improvements will be very plain, with little simple [storefront](#), a low-cost entrance, minimal interior partitioning, and low-cost fixtures.
- Average quality units will usually have good [storefront](#), some ornamentation, plain interior finish.
- Good quality units will have good front and trim, some ornamentation, some interior embellishment.
- High quality units will be individually designed structures with high-cost [storefronts](#) and well-finished interiors.

Note: [Service](#), [parts](#), and [repair](#) garage areas should be listed separately using the appropriate model.

TYPE	EXTERIOR WALLS	INTERIOR FINISH	PLUMBING / ELECTRICAL	HEATING/COOLING
Excellent	Face brick or stone, good metal or concrete and glass panels, good EIFS	Plaster, good acoustic tile, good terrazzo, stone, rubber tile carpet, good finishes and trim	Special lighting, good fixtures and plumbing throughout	Warm and cool air - zoned package AC
Good	Brick, block stucco, masonry veneer, or siding, sandwich panels , good storefront and ornamentation	Plaster, good acoustic tile , vinyl tile and carpet, terrazzo display floor, good office area	Good display and office lighting, rest rooms, standard fixtures	Package AC
Average	Brick, block, concrete, siding, veneer trim, storefront , some ornamentation	Plaster or drywall, acoustic tile , vinyl composition, office, sales cubicles	Store and office lighting, small rest rooms	Package AC
Low Cost	Low-cost block or brick, tilt-up concrete panels, low-cost stucco or siding, simple storefront , low-cost entrance.	Very plain, acoustic tile , drywall, few partitions, minimum finish small office area	Adequate lighting, minimum plumbing	Package AC

MODEL 115 - X ILLUSTRATIONS



MODEL 115 - X ILLUSTRATIONS



MODEL 116 - X BARBER - BEAUTY SHOP

When these are individual structures, they tend to be single story, with wood frame or masonry exterior walls. Interiors are typically drywall with paint or paper, or paneling. Most are plain with little trim or ornamentation. Most have large open interiors with few partitions, resilient flooring such as vinyl or asphalt tile, and plumbing and fixtures commensurate with the quality of the building.

- Lower quality improvements will be very plain, with simple storefront, a low-cost entrance, minimal interior partitioning, and low-cost fixtures.
- Average quality units will usually have good [storefront](#), some ornamentation, plain interior finish.
- Good quality units will have good front and trim, some ornamentation, some interior embellishment.
- High quality units will be individually designed structures with high cost [storefronts](#) and well-finished interiors.

TYPE	EXTERIOR WALLS	INTERIOR FINISH	PLUMBING / ELECTRICAL	HEATING/COOLING
Excellent	Stone, face brick, best metal, fine display fronts	Plaster, good acoustic tile , carpet, vinyl, good finishes and trim	Special lighting, good fixtures and ample plumbing fixtures for multiple workstations	Package AC
Good	Brick, block, stucco, good metal or stone display front	Plaster, acoustic tile , vinyl and carpet	Good lighting, fixtures, and adequate plumbing	Package AC
Average	Brick, block, plain storefront , some ornamentation	Plaster or drywall, acoustic tile , vinyl composition, some carpet	Adequate plumbing and electrical, lower cost fixtures	Wall furnace, room AC
Low Cost	Low-cost block or brick, plain front	Very plain, acoustic tile , drywall, vinyl	Adequate lighting, minimum plumbing	Wall furnace, room AC

MODEL 116 - X ILLUSTRATIONS



MODEL 116 - X ILLUSTRATIONS



MODEL 117 - X WAREHOUSE FOOD STORE

These structures are large markets of warehouse construction offering limited perishable products, excluding any [built-in](#) coolers or refrigerated storage. The better qualities will merge into the [supermarket model](#), with a number of finished major product departments, but **excluding** any storage/display walk-in cooler boxes. The better qualities will also have partitioned offices. Low quality structures are unfinished shell types with minimum code throughout. The following are **not** included in the costs: Furnishings, signs, trade fixtures, walk-in coolers and checkout or food service equipment.

- Lower quality improvements will be very plain, with little or no exterior embellishment, minimal interior partitioning, and low-cost fixtures.
- Average quality units will usually be functional buildings with little adornment and plain interior finish.
- Good quality units will have variations from a standard design, with some ornamentation and added interior items.
- High quality units will be individually designed structures with high-cost [storefronts](#) and well-finished interiors.

TYPE	EXTERIOR WALLS	INTERIOR FINISH	PLUMBING / ELECTRICAL	HEATING/COOLING
Good	Brick, tilt-up , brick veneer, stucco, or wood or steel siding, open frame and plain front	Plaster or drywall, partitioned offices, finished ceilings, vinyl composition	Good lighting and plumbing, snack bar, etc.	Package AC
Average	Brick, block, tilt-up, stucco or siding, sandwich panels , pipe or pre-engineered columns, small front	Painted walls, some partitions, office area, some vinyl composition	Adequate lighting and plumbing, few extra services	Package AC
Low Cost	Low cost block or brick, tilt-up concrete panels, low cost stucco or single wall siding, very plain	Unfinished, shell type, few partitions, sealed concrete floor	Minimum food store lighting and plumbing, small restrooms	Evaporative cooling, space heaters

MODEL 117 - X ILLUSTRATIONS



MODEL 117 – X ILLUSTRATIONS



MODEL 118 - X WAREHOUSE SHOWROOM STORE

These structures are typical of the large walk-through furniture outlets with a semi-finished showroom and large carryout warehouse as one complete facility. Low quality structures are unfinished shell types with minimum code throughout. Better qualities have partitioned offices. The following are **not** included in the costs: Furnishings, signs, trade fixtures and checkout or food service equipment.

- Lower quality improvements will be very plain, with little or no exterior embellishment, minimal interior partitioning, and low-cost fixtures.
- Average quality units will usually be functional buildings with little adornment and plain interior finish.
- Good quality units will have variations from a standard design, with some ornamentation and added interior items.
- High quality units will be individually designed structures with high-cost [storefronts](#) and well-finished interiors.

TYPE	EXTERIOR WALLS	INTERIOR FINISH	PLUMBING / ELECTRICAL	HEATING/COOLING
Good	Brick, block, tilt-up , stucco, wood or sandwich panel siding, open or steel frame, small front, some trim	Plaster, or drywall, partitioned offices, finished showroom ceilings and floors	Good display and office lighting, adequate restrooms	Package AC
Average	Average block, tilt-up , stucco, wood or steel siding, open pipe, wood or pre-engineered frame, plain front	Painted walls, some partitions, office area, vinyl composition, sales cubicles	Display, office and warehouse lighting, small restrooms	Package AC
Low Cost	Cheap block, tilt-up , single wall wood or steel siding, box frame or studs, light steel frame, very plain	Unfinished, shell type, few partitions, concrete floor, little display finish	Minimum lighting, outlets and plumbing fixtures	Evaporative cooling, space heaters

MODEL 118 - X ILLUSTRATIONS



MODEL 118 – X ILLUSTRATIONS



MODEL 119 - X MINI - MART CONVENIENCE MARKET

Mini-mart food stores are small convenience outlets that cater primarily to a transient trade for self-service snack foods and beverages. The better stores will have public restrooms and limited hot or deli food preparation and service areas. Lower qualities are minimum code throughout.

The following are not included in the costs: Display cases/fronts/freezers/coolers or freezer/cooler doors and other trade fixtures.

Note: By using [HA](#) or [HANC](#), the appraiser may or may not include the cost of walk-in cooler boxes from a segregated system listing. The square foot component for this model does not include the cost of walk-in cooler boxes. In a square foot listing, use component [HSFC \(built-in coolers\)](#) to add the cooler cost.

Note: For a discussion of [walk-in cooler boxes](#) and [mini-mart convenience markets](#) with self-service gas, see [Volume I, Appendix A](#).

- Lower quality improvements will be very plain with little or no exterior embellishment, minimal interior partitioning, and low-cost fixtures.
- Average quality units will usually be functional buildings with little adornment and plain interior finish.
- Good quality units will have variations from a standard design, with some ornamentation and added interior items.
- High quality units will be individually designed structures with high-cost [storefronts](#) and well-finished interiors.

TYPE	EXTERIOR WALLS	INTERIOR FINISH	PLUMBING / ELECTRICAL	HEATING/COOLING
Excellent	Decorative block, brick, best metal panels, good glass entrance	Good drywall, acoustic tile , good pavers, limited food prep. area	Good lighting, good fixtures and plumbing, tiled restrooms	Package heat / AC
Good	Brick, best block or stucco, , good storefront and ornamentation	Good acoustic , ceramic tile, security partitioning, some snack prep area	Good lighting and outlets, public restrooms, standard fixtures	Package heat / AC
Average	Brick, block, stucco, siding, some mansard , parapet ornamentation	Typical food booth, acoustic tile , vinyl composition, adequate support	Adequate lighting and outlets, small employees rest room	Package heat / AC
Low Cost	Minimum block, cheap brick, stucco, siding, metal panels, small front	Minimum finish and partitions	Minimum code throughout	Package heat / AC

MODEL 119 - X ILLUSTRATIONS



MODEL 119 - X ILLUSTRATIONS



MODEL 120 - X DRUGSTORE

These buildings include both small neighborhood pharmacies and the large chain discount-type stores with a variety of merchandise departments including convenience foods containing built-in refrigerators.

The better qualities have some [storefront](#) and well-finished interiors. Some storage and office areas commensurate with the overall quality of the building are included.

The following are **not** included in the costs: Furnishings, signs, display freezers and cooler or other trade fixtures, checkout or prescription and food service equipment.

Note: By using [HA](#) or [HANC](#), the appraiser may or may not include the cost of walk-in cooler boxes from a segregated system listing. The square foot component for this model does not include the cost of walk-in cooler boxes. In a square foot listing, use component [HSFC \(built-in coolers\)](#) to add the cooler cost. For more information about walk-in cooler boxes, see [Volume I, Appendix A](#).

- Lower quality improvements will be very plain, with little or no exterior embellishment, minimal interior partitioning, and low-cost fixtures.
- Average quality units will have some trim, average quality fixtures and design.
- Good quality units will have well finished interiors, better facilities, and some exterior ornamentation.
- High quality units will have well finished interiors, fine display fronts, and special lighting and fixtures.

TYPE	EXTERIOR WALLS	INTERIOR FINISH	PLUMBING / ELECTRICAL	HEATING/COOLING
Excellent	Face brick or brick veneer, best designs, highly ornamental exterior	Typically best variety type, good acoustic , vinyl tile and carpet	Good departmental lighting, good pharmacy and convenience foods	Package A.C.
Good	Brick best block, stucco, good storefront and ornamentation	Drywall, acoustic tile , vinyl comp. ,includes typical mini-drive-thru	Good lighting and outlets, standard fixtures and pharmacy	Package A.C.
Average	Brick or concrete, stucco or siding, some mansard , parapet ornamentation	Drywall, acoustic tile , some vinyl, little trim	Adequate lighting and outlets, rest rooms, prescription and sundries departments	Package AC
Low Cost	Minimum block, brick, stucco or siding on studs, small front, little trim.	Painted exterior walls, minimum retail finish, typical low-end chain	Adequate lighting, plumbing and pharmacy, small employees restrooms	Package A.C.

MODEL 120 - X ILLUSTRATIONS



MODEL 120 - X ILLUSTRATIONS



MODEL 130 - X MALL ANCHOR DEPARTMENT STORE

These buildings are often one or two stories that are a transition between the pure discount store and the old full-line department store. The front elevations usually vary with the quality of the store. The higher quality anchor stores have some display areas and fronts while, at the lower quality levels, the entries are relatively plain.

Most anchor stores have some [elevators](#) and [escalators](#). Floor coverings are a mixture of carpet and resilient tile, with the better qualities utilizing high-traffic type floor finishes such as [terrazzo](#). Anchor stores generally have combined heating and cooling systems and good store lighting. Allowances are included for suitable office and employee areas and restroom facilities.

The following are **not** included in the costs: Furnishings, signs, trade fixtures and retail or food service equipment.

- Lower quality improvements will be very plain, with little architectural embellishment, minimal interior partitioning, and low-cost fixtures.
- Average quality units will usually have good storefront, some ornamentation, plain interior finish.
- Good quality units will have good fenestration and trim, and average interior embellishment.
- High quality units will be individually designed structures with high quality interior and exterior finish.

TYPE	EXTERIOR WALLS	INTERIOR FINISH	PLUMBING / ELECTRICAL	HEATING/COOLING
Good	Brick, block, stucco, good metal and glass or stone, adequate entry displays	Plaster, acoustic plaster or tile , vinyl, and carpet	Good lighting, fixtures, and adequate plumbing	Zoned heating and cooling
Average	Brick, block, stucco, concrete panels, some entry displays and mall front trim only	Drywall, some covering, acoustic tile , some carpet, vinyl, wood or ceramic	Adequate plumbing and electrical	Zoned heating and cooling
Low Cost	Brick, concrete block or EIFS , little trim, plain entries, no displays	Painted, some drywall, acoustic , Typical big box or jr. dept. store	Adequate lighting, adequate plumbing	Package A.C.

MODEL 130 - X ILLUSTRATIONS



MODEL 130 - X ILLUSTRATIONS



MODEL 131 - X DEPARTMENT STORE

These are often two or more story structures designed to display and sell multiple lines of merchandise. The front elevations vary with the quality of the store. The higher quality structures have large, ornate display areas and fronts while, at the average quality level, the displays are relatively smaller.

Most have [elevators](#) and [escalators](#). Floor coverings are a mixture of resilient flooring and carpet, with better quality stores using high traffic surfaces such as [terrazzo](#). Department stores usually have combined heating and cooling systems and good store lighting. Allowances are made for suitable amounts of office space, employee areas, merchandise receiving and storage, and rest rooms.

- Lower quality improvements will be very plain, with little architectural embellishment, minimal interior partitioning, and low-cost fixtures.
- Average quality units will usually have good [storefront](#), some ornamentation, plain interior finish.
- Good quality units will have good fenestration and trim, and average interior embellishment.
- High quality units will be individually designed structures with high quality interior and exterior finish.

TYPE	EXTERIOR WALLS	INTERIOR FINISH	PLUMBING / ELECTRICAL	HEATING/COOLING
Excellent	Stone, face brick, best metal and glass, or concrete panels, fine display fronts	Plaster, vinyl, and ornamental finishes and trim, terrazzo and carpet	High luminosity, many good outlets, tiled rest rooms, good quality plumbing	Zoned heating and cooling
Good	Brick, block, stucco, good metal and glass or stone, good display fronts	Plaster, acoustic plaster or tile , vinyl, and carpet	Good lighting, fixtures, and adequate plumbing	Zoned heating and cooling
Average	Brick, block, stucco, concrete panels, shallow display fronts	Plaster or drywall, acoustic tile , rubber or vinyl composition, ceramic, some carpet	Adequate plumbing and electrical, lower cost fixtures	Zoned heating and cooling
Low Cost	Brick, concrete or face block, some all front trim only	Drywall, some covering, acoustic tile , some carpet, ceramic or vinyl	Minimum lighting, minimum plumbing	Zoned heating and cooling

MODEL 131 - X ILLUSTRATIONS



MODEL 132 - X DISCOUNT STORE

These buildings are large, one-story structures, with few partitions. Even though some of the better quality discount stores are divided by departments, they generally will not match the quality of construction found in the department stores. Some stores such as the large discount furniture outlets combine [discount](#) and [storage](#) warehouse buildings.

Better qualities will have some [storefront](#) and well-finished interiors that may approach the low quality department store in cost and appearance. Lower cost structures will have little or no [storefront](#) and minimal interior finish. Some storage areas, rest room partitions, and office area commensurate with the quality of the building are included in the cost.

- Lower quality improvements will be very plain, with little or no [storefront](#) and minimal interior facilities.
- Average quality units will usually have very little storefront, and standard interior finish with some partitions.
- Good quality units will have good [storefront](#) with some fenestration and trim, and well-finished interior with some partitions.
- High quality units will approach the low-cost department store in interior finish, with departmental partitions and well-finished interiors. Good [storefront](#) and ample fenestration but resembling the good quality structures on the exterior. An interior inspection should be made to determine the appropriate quality.

TYPE	EXTERIOR WALLS	INTERIOR FINISH	PLUMBING / ELECTRICAL	HEATING/COOLING
Excellent	Tilt-up panels, brick, steel columns, wide span, good front, some ornamentation	Acoustic tile, plaster or drywall, good offices, rubber or vinyl composition	Good lighting and outlets, good rest rooms	Zoned heating and cooling
Good	Brick or block, tilt-up, wood or steel columns and trusses, good sandwich panels, some ornamentation	Acoustic tile, plaster or drywall, good offices, rubber or vinyl composition	Good lighting and outlets, good rest rooms	Package heat / AC
Average	Brick, block, tilt-up stucco on wood frame, or heavy studs, sandwich panels, plain front	Acoustic tile, drywall, small office area, few partitions, vinyl composition	Adequate lighting and outlets, standard fixtures	Package heat / AC
Low Cost	Minimum block or tilt-up, pipe or wood columns, steel panels(partly finished on interior) small front	Acoustic tile, drywall, few partitions, minimum finish and office	Minimum lighting, minimum plumbing	Gas space heat / evaporative cooling

MODEL 132 - X ILLUSTRATIONS



MODEL 132 - X ILLUSTRATIONS



MODEL 133 - X WAREHOUSE DISCOUNT STORE

These structures are of warehouse construction with minimal interior partitioning. Membership stores fall into this category. Low quality structures are unfinished shell types with minimum code throughout. Better qualities have partitioned offices. The following are **not** included in the costs: Furnishings, signs, trade fixtures and checkout or food service equipment.

- Lower quality improvements will be very plain, with little or no exterior embellishment, minimal interior partitioning, and low-cost fixtures.
- Average quality units will usually be functional buildings with little adornment and plain interior finish.
- Good quality units will have variations from a standard design, with some ornamentation and added interior items.
- High quality units will be individually designed structures with high-cost [storefronts](#) and well-finished interiors.

TYPE	EXTERIOR WALLS	INTERIOR FINISH	PLUMBING / ELECTRICAL	HEATING/COOLING
Good	Brick, block, tilt-up , stucco or siding, sandwich panels , plain fronts	Plaster or drywall, partitioned office, good finished ceilings, vinyl floor	Fluorescent lighting, adequate outlets and restrooms, good extras	Package AC
Average	Average brick, block, tilt-up , good stucco or siding, sandwich panels . Open pipe, wood or pre-engineered frame, some trim	Painted walls, some partitions, office area, vinyl composition and acoustic	Adequate lighting, restrooms, small snack bar or deli/fast food	Package AC
Low Cost	Cheap block or brick, tilt-up concrete panels, stucco or siding. No glass except front door	Unfinished, shell type, few partitions, concrete floor	Minimum code throughout	Evaporative cooling, space heaters

MODEL 133 - X ILLUSTRATIONS



MODEL 133 – X ILLUSTRATIONS

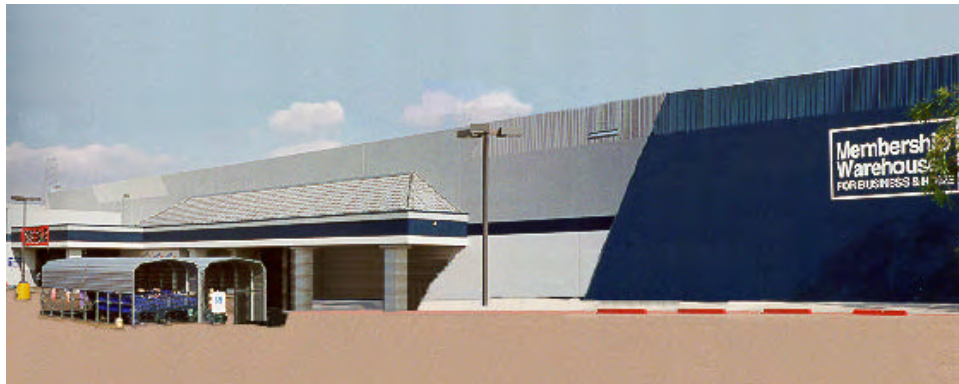

MODEL 134 - X MEGA-WAREHOUSE DISCOUNT STORE

These structures are very large discount stores of warehouse type construction, over 200,000 square feet, with minimal interior partitioning. Low quality structures are unfinished shell types with minimum code throughout. Better qualities have partitioned offices and some finished sales areas for specialty personal products, auto supplies, groceries and fast food/snack bar outlets commensurate with the quality.

The following are not included in the costs: Furnishings, signs, built-in coolers or refrigerated storage, trade fixtures and checkout or food service equipment.

- Lower quality improvements will be very plain, with little or no exterior embellishment, minimal interior partitioning, and low-cost fixtures.
- Average quality units will usually be functional buildings with little adornment and plain interior finish.
- Good quality units will have variations from a standard design, with some ornamentation and added interior items.
- High quality units will be individually designed structures with high-cost [storefronts](#) and well-finished interiors.

TYPE	EXTERIOR WALLS	INTERIOR FINISH	PLUMBING / ELECTRICAL	HEATING/COOLING
Good	Decorative brick, block, tilt-up, stucco or siding, sandwich panels, small fronts, some trim	Painted walls, partitioned departments, partial finished ceilings, vinyl floors	Good fluorescent lighting, outlets and restrooms, good extras	Package AC
Average	Good steel frame, block, tilt-up or siding, good roof, bar or web joists, good fenestration	Painted walls, some partitions, office area, some vinyl composition and acoustic	Adequate lighting, restrooms, small snack bar or deli/fast food	Package AC
Low Cost	Large tilt-up, light panelized const., metal siding and roof, rigid steel frame, built-up roof, exposed insulation	Unfinished, small offices, hardened slab throughout	Adequate lighting and plumbing fixtures, food services, snack bar	Evaporative cooling, space heaters

MODEL 134 - X ILLUSTRATIONS



MODEL 134 – X ILLUSTRATIONS



MODEL 141 - X NEIGHBORHOOD SHOPPING CENTER

Neighborhood shopping centers are typically a row of open stores comprising a single line of [storefronts](#) with individual service entrances in the rear. They are generally one-story projects and may or may not have a major anchor. Typical anchors in a neighborhood center are supermarkets, drug stores, discount stores, or bank buildings.

Models 141, 142, and 143 are to be used for the strip retail portions of the shopping center. Shopping center complexes will often have three distinct parts: major anchors, retail strip stores, and mall concourse area. Each should be listed individually based on its own model, class, and quality.

Note: See [Volume I, Appendix A](#) for more detailed listing procedures.

- Low quality improvements will be very plain with minimal openings, [storefront](#), and stark interior facilities.
- Average quality units will usually have very plain [storefronts](#), plain interior finish, and no service areas.
- Good quality units will have plain [storefronts](#) with some trim, and plain interior finish with some partitions.
- High quality units will have better [storefronts](#), good trim, service areas, and good interior finish with ample partitions.

TYPE	EXTERIOR WALLS	INTERIOR FINISH	PLUMBING / ELECTRICAL	HEATING/COOLING
Excellent	Tilt-up sandwich panels, brick, block, bearing or light frame, web or bar joists, good front, some ornamentation	Acoustic tile, plaster, or drywall, vinyl composition, partitioning	Good retail lighting and outlets, adequate plumbing	Package heat / AC
Good	Brick, or block, tilt-up, wood or steel columns and trusses, good sandwich panels, some ornamentation	Acoustic tile, plaster or drywall, floor slab, vinyl composition, some partitioning	Standard retail lighting and outlets, standard plumbing	Package heat / AC
Average	Brick, block, tilt-up stucco on wood frame, or heavy studs, sandwich panels, plain front	Acoustic tile, drywall, few partitions, vinyl composition	Average retail lighting and plumbing	Package heat / AC
Low Cost	Minimum block or tilt-up, pipe or wood columns, steel panels, partly finished on interior, small front	Drywall, minimum finish, bare retail space	Minimum lighting, minimum plumbing	Gas space heat / evaporative cooling

MODEL 141 - X ILLUSTRATIONS



MODEL 141 - X ILLUSTRATIONS



MODEL 142 - X COMMUNITY SHOPPING CENTER

Community shopping centers are an intermediate group of stores, also called plazas. They are generally much larger than neighborhood centers, better designed, and typically but not always, support a major anchor. Some better boutique and specialty centers may have no major anchor, but rather may emphasize a particular market, such as outlet sales, or may have a common architectural theme for a group of small stores. Both one- and two-story buildings may be found, and typical anchor tenants are secondary or junior department stores, specialty retail-discount stores, or major restaurant buildings.

Models 141, 142, and 143 are to be used for the strip retail portions of the shopping center. Shopping center complexes will often have three distinct parts: major anchors, retail strip stores, and mall concourse area. Each should be listed individually based on its own model, class, and quality.

Note: See [Volume I, Appendix A](#) for more detailed listing procedures.

- Average quality units will usually have plain [storefronts](#) and average interior finish.
- Good quality units will have good [storefronts](#) and display areas, and good interior finish with good lighting and display areas.
- High quality units will have best [storefronts](#) and display areas, excellent trim, best interior finish with special lighting and fixtures.

TYPE	EXTERIOR WALLS	INTERIOR FINISH	PLUMBING / ELECTRICAL	HEATING/COOLING
Excellent	Best masonry veneer, some face brick, fine ornamentation and displays	Best plaster, ornamental ceilings, paneling, ceramic, hardwood , carpet	Special retail lighting and outlets, good plumbing	Zoned warm and cool air
Good	Face brick, best block or stucco, masonry veneer, staggered setbacks, mansard ornamentation, good displays	Plaster and paneling, ornamental finishes, carpet, plain terrazzo	Extensive lighting, and outlets, good plumbing	Zoned warm and cool air
Average	Brick, block, stucco, best tilt-up , adequate front facade, adequate displays	Drywall or plaster, good tile ceilings, vinyl composition, carpet	Average retail lighting and adequate plumbing	Package heat / AC

MODEL 142 - X ILLUSTRATIONS



MODEL 142 - X ILLUSTRATIONS



MODEL 143 - X REGIONAL SHOPPING CENTER

Regional shopping centers contain a large number of strip stores adjoining a two-story enclosed mall area with several anchor tenants also opening into the multistory mall area.

Models 141, 142, and 143 are to be used for the strip retail portions of the shopping center. Shopping center complexes will often have three distinct parts: major anchors, retail strip stores, and mall concourse area. Each should be listed individually based on its own model, class, and quality.

Note: See [Volume I, Appendix A](#) for more detailed listing procedures.

- Average quality units will usually have plain [storefronts](#) and average interior finish.
- Good quality units will have good [storefronts](#) and display areas, and good interior finish with good lighting and display areas.
- High quality units will have best [storefronts](#) and display areas, excellent trim, best interior finish with special lighting and fixtures.

TYPE	EXTERIOR WALLS	INTERIOR FINISH	PLUMBING / ELECTRICAL	HEATING/COOLING
Excellent	Stone, face brick, best metal and glass storefront, staggered setbacks, fine ornamentation and displays	Best plaster, ornamental ceilings, paneling, hardwood , carpet	Special retail lighting, many good outlets, good plumbing and rest rooms	Zoned warm and cool air
Good	Brick, concrete, metal and glass, steel frame, brick, best block and stucco, good displays	Good partitions, acoustic ceilings , terrazzo , carpet, vinyl tile	Extensive lighting, and outlets, adequate employee restrooms	Zoned warm and cool air
Average	Steel columns , web or bar joists, brick, block, tilt-up, adequate fronts	Good acoustic tile , vinyl composition, some carpet, masonry partitions	Average retail lighting and plumbing, minimum service facilities	Package heat / AC

MODEL 143 - X ILLUSTRATIONS





MODEL 143 - X ILLUSTRATIONS

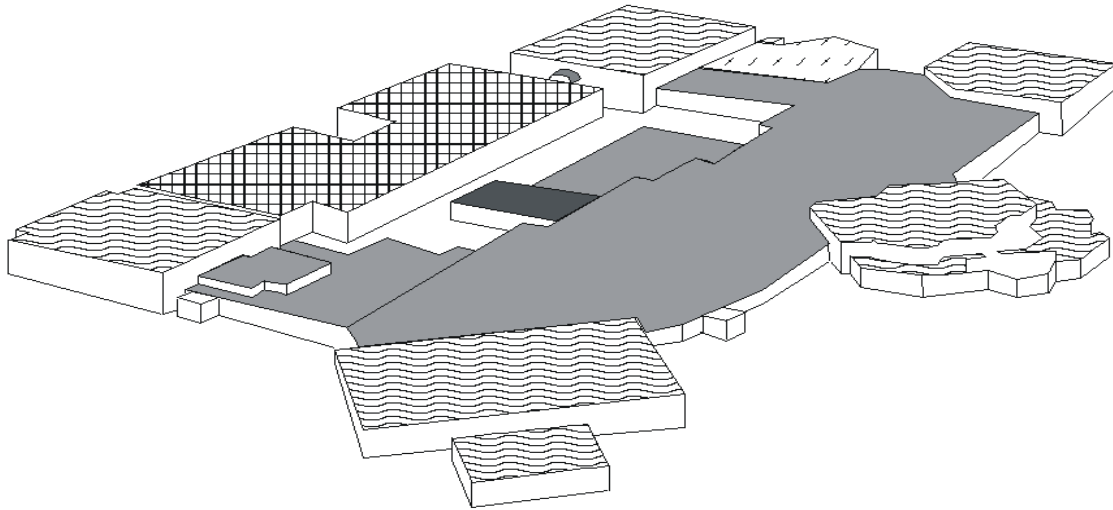

MODEL 143 - X ILLUSTRATIONS

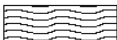

-  THEATER - WALK-IN 251 - X
-  STRIP STORE AND MALL AREAS 143 - X
-  TWO STORY DEPARTMENT STORES 130 - X
-  PARKING GARAGE ABOVE GRADE 291 - X
-  RESTAURANT 201 - X

-
- | | |
|--|---|
| 1. Model 144-1 through 5 and 9, | NEIGHBORHOOD SHOPPING CENTER-SHELL ONLY |
| Model 145-1 through 5 and 9, | COMMUNITY SHOPPING CENTER-SHELL ONLY |
| Model 146-1 through 5 and 9, | REGIONAL SHOPPING CENTER-SHELL ONLY |
| Model 153-1 through 5 and 9, | BUSINESS OFFICE-SHELL ONLY |
| Model 154-1 through 5 and 9, | BUSINESS OFFICE, 1st FLOOR PARKING-SHELL ONLY |
| Model 388-1 through 5 and 9, | INDUSTRIAL BUILDING-SHELL ONLY |

These models may be used to identify an improvement whose interior components are not yet in place or have been removed.

When building the above improvements, developers may erect the shell of the building (foundation, walls, roof structure and cover) and delay construction of the interior components (interior partitions, plumbing, electric, floor structure or cover) until the improvement is leased. In addition, leasing agreements may require the tenant to remove many of the interior components at the end of the lease, leaving the building a shell.

In either case, during periods of economic slowdown, the period in which the building is a shell may be quite long. Using these models will allow the assessor to identify these shell buildings for callbacks plus avoid any confusion caused by comparing their square foot cost with fully constructed buildings of the same model.

MODEL 151 - X BUSINESS OFFICE

Business offices are buildings designed for general commercial occupancy, and include administrative, government, and corporate uses. They are normally divided into relatively small units for tenant use.

Floor finishes are normally carpet, [terrazzo](#), or vinyl. Ceiling finishes vary with the quality of the building. [Luminous ceilings](#) and high intensity fluorescent lighting are found in the better quality improvements.

The number and quality of plumbing fixtures generally correspond to the quality of the building. Metal partitions and commercial plumbing fixtures are found at all quality levels.

If part of an office building has another occupancy such as a bank or store, that portion should be sectionalized using the appropriate model, or interior overrides should be used.

- Lower quality improvements will be plain with little exterior finish, minimal interior partitioning, and low-cost fixtures.
- Average quality units will have few architectural embellishments, average quality fixtures and design. The exterior may be of lower quality but have better interior finish, which raises the overall quality.
- Good quality units will generally fit into a group where rental return must justify the cost of the building. They will have some special exterior and interior features, with [double glazed](#) or [heat absorbent glass](#).
- High quality units will be prestige buildings, built as home offices for major corporations. The exterior will usually have a great deal of stone, steel, or bronze. Interiors will be best quality, with many partitions and excellent fixtures.

TYPE	EXTERIOR WALLS	INTERIOR FINISH	PLUMBING / ELECTRICAL	HEATING/COOLING
Excellent	Best metal or stone, stone ornamentation, brick or block back-up, steel frame, masonry and glass, studs and steel columns, bar or web joists, EIFS, solar or tinted glass	Plaster, paneling, best veneers, carpet, terrazzo, vinyl tile, best wall coverings	Luminous ceilings, many outlets, many private rest rooms, good fixtures	Zoned hot and chilled water
Good	Good metal and solar glass, face brick, precast concrete panels, steel frame or bearing walls, best stucco on good frame, stone trim, good front	Drywall and plaster, good partitions, acoustic tile, carpet and vinyl	Good fluorescent, high intensity lighting, good rest rooms and fixtures	Zoned hot and chilled water, package heat / AC
Average	Brick or concrete, metal and glass panels, steel or concrete frame, stucco or wood siding on wood or steel studs, insulated wall or sandwich panels, adequate fenestration, some trim	Plaster or drywall, acoustic tile, vinyl composition, some extras	Average intensity fluorescent lighting, average rest rooms	Zoned hot and chilled water, package heat / AC
Low Cost	Minimum cost walls and fenestration, steel and aluminum on light frame, masonry bearing walls, stucco or wood siding, light rafters, very plain	Very plain, acoustic tile, asphalt tile, few partitions	Minimum office lighting, outlets, and plumbing fixtures	Evaporative cooling, forced air or wall furnace

MODEL 151 - X ILLUSTRATIONS



MODEL 151 - X ILLUSTRATIONS



MODEL 151 - X ILLUSTRATIONS



MODEL 151 - X ILLUSTRATIONS



MODEL 152 - X BUSINESS OFFICE - FIRST FLOOR PARKING

Business offices are buildings designed for general commercial occupancy and include administrative, government, and corporate uses. They are normally divided into relatively small units for tenant use. These models are similar to the business office model (151 - X) but have a first floor open for parking, and tend to be less than 4 stories, rather than high-rise structures.

Floor finishes are normally carpet, [terrazzo](#), or vinyl. Ceiling finishes vary with the quality of the building. [Luminous ceilings](#) and high intensity fluorescent lighting are found in the better quality improvements.

The number and quality of plumbing fixtures generally correspond to the quality of the building. Metal partitions and commercial plumbing fixtures are found at all quality levels.

If part of an office building has another occupancy such as a bank or store, that portion should be sectionalized using the appropriate model, or interior overrides should be used.

Refer to [Appendix A](#) for detailed listing procedures for this model.

- Lower quality improvements will be plain with little exterior finish, minimal interior partitioning, and low-cost fixtures.
- Average quality units will have few architectural embellishments, average quality fixtures and design. The exterior may be of lower quality but have better interior finish, which raises the overall quality.
- Good quality units will generally fit into a group where rental return must justify the cost of the building. They will have some special exterior and interior features, with [double glazed](#) or [heat absorbent glass](#).
- High quality units will be prestige buildings, built as home offices for major corporations. The exterior will usually have a great deal of stone, steel, or bronze. Interiors will be best quality, with many partitions and excellent fixtures.

TYPE	EXTERIOR WALLS	INTERIOR FINISH	PLUMBING / ELECTRICAL	HEATING/COOLING
Excellent	Best metal or stone, stone ornamentation, brick or block back-up, steel frame, masonry and glass, studs and steel columns, bar or web joists, EIFS, solar or tinted glass	Plaster, paneling, best veneers, carpet, terrazzo, vinyl tile, best wall coverings	Luminous ceilings, many outlets, many private rest rooms, good fixtures	Zoned hot and chilled water
Good	Good metal and solar glass, face brick, precast concrete panels, steel frame or bearing walls, best stucco on good frame, stone trim, good front	Drywall and plaster, good partitions, acoustic tile, carpet and vinyl	Good fluorescent, high intensity lighting, good rest rooms and fixtures	Zoned hot and chilled water, package heat / AC
Average	Brick or concrete, metal and glass panels, steel or concrete frame, stucco or wood siding on wood or steel studs, insulated wall or sandwich panels, adequate fenestration, some trim	Plaster or drywall, acoustic tile, vinyl composition, some extras	Average intensity fluorescent lighting, average rest rooms	Zoned hot and chilled water, package heat / AC
Low Cost	Minimum cost walls and fenestration, steel and aluminum on light frame, masonry bearing walls, stucco or wood siding, light rafters, very plain	Very plain, acoustic tile, asphalt tile, few partitions	Minimum office lighting, outlets and plumbing fixtures	Evaporative cooling, forced air or wall furnace

MODEL 152 - X ILLUSTRATIONS



MODEL 152 - X ILLUSTRATIONS



MODEL 161 - X CENTRAL BANK

These structures include savings and loan institutions and credit unions where the design is of the same type as a bank. While a branch bank may be a single-use facility, the central bank may be more office building in character. Administrative offices, usually the upper floors, should be listed using appropriate interior overrides. Exteriors have some ornamentation at all quality levels, with the better qualities using stone, ornamental concrete, brick, and or solar glass. Interiors may be plaster or drywall with special detailing in some areas. Some office and storage area is typical, as are floor finishes such as [terrazzo](#), carpet, and vinyl tile or sheeting. These structures also typically include drive-up windows, night depositories, and surveillance systems commensurate with the quality of the building.

Costs do not include banking fixtures or equipment, safe deposit boxes, or [vault doors](#). The exterior wall component cost for banks includes drive-up windows and night deposit chutes/boxes. The cost of the [vault](#) is **not** included in the segregated system [HA](#) component but is included in the square foot system component cost.

- Lower quality improvements will have some exterior finish, small entrances, minimal interior partitioning and finishes.
- Average quality units will have individual deviations from a standard design, average quality fixtures and design.
- Good quality banks will generally be designed to give the impression of solidity, with good quality interior finishes.
- High quality units will be larger, with a great deal of stone masonry and massive roof and wall structure. Interiors will be of heavy construction with excellent finishes.

TYPE	EXTERIOR WALLS	INTERIOR FINISH	PLUMBING / ELECTRICAL	HEATING/COOLING
Excellent	Heavy, substantial, marble, granite, mosaics, bronze and solar glass, stone or face brick veneer, metal and glass panels, best glass	Plaster and drywall, paneling, vinyl wall finishes, marble, terrazzo , carpet	Best lighting and closed circuit TV, best plumbing and rest rooms	Zoned hot and chilled water
Good	Highly ornamental, marble, granite, best glass, brick veneer, metal and glass panels, EIFS , sandwich panels , brick trim, good fenestration	Drywall and plaster, paneling, good partitions, carpet and vinyl	Good fluorescent ceiling panels, good outlets, adequate rest rooms	Zoned hot and chilled water
Average	Good brick, ornamental concrete, block, tilt-up, sandwich panels, good store type front with some trim	Plaster or drywall, acoustic tile , vinyl composition, some terrazzo, pavers or ceramic, good detail	Good lighting and outlets, adequate rest rooms	Zoned hot and chilled water, package heat / AC
Low Cost	Brick, concrete, metal panels, stucco or siding, tilt-up, little trim	Plaster or drywall, vinyl composition, acoustic tile , few partitions	Minimum bank lighting, minimum rest room facilities	Package heat / AC

MODEL 161 - X ILLUSTRATIONS

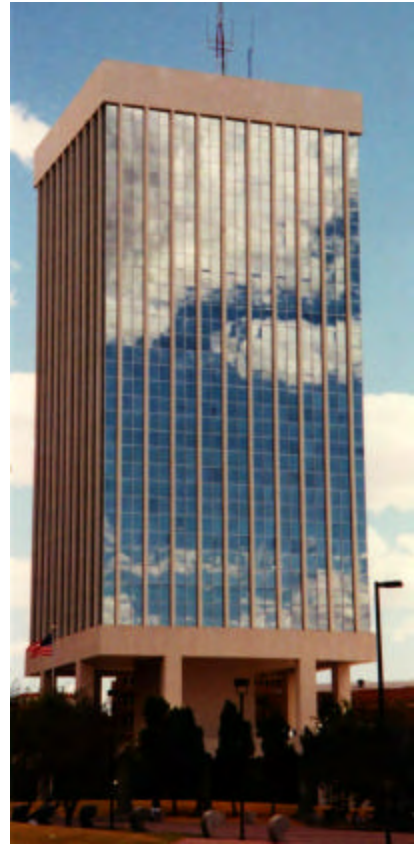

MODEL 161 - X ILLUSTRATIONS



MODEL 162 - X BRANCH BANK

These structures include savings and loan institutions and credit unions where the design is similar to a bank. Unlike the central bank, branch banks tend to be single purpose, low-rise, neighborhood facilities. Exteriors have some ornamentation at all quality levels, with the better qualities using stone, ornamental concrete, brick, and or solar glass. Interiors may be plaster or drywall with special detailing in some areas. There is some office and storage area. The office area may be open and located in the same general area as the main banking services. Floor coverings are usually [terrazzo](#), vinyl asbestos, or vinyl sheet. These structures also typically include drive-up windows, night depositories, and surveillance systems commensurate with the quality of the building.

Costs do not include banking fixtures or equipment, safe deposit boxes, or [vault doors](#). The exterior wall component cost for banks includes drive-up windows and night deposit chutes/boxes. The cost of the [vault](#) is **not** included in the segregated system HA component but is included in the square foot system component cost.

- Lower quality improvements will have little exterior finish, small entrances, minimal interior partitioning and finishes.
- Average quality units will have individual deviations from a standard design, average quality fixtures and design.
- Good quality structures will have better quality exterior ornamentation, with good quality interior finishes.
- High quality units will be larger, with substantial exterior embellishment. Interiors will be of high quality construction with excellent finishes.

TYPE	EXTERIOR WALLS	INTERIOR FINISH	PLUMBING / ELECTRICAL	HEATING/COOLING
Excellent	Heavy, substantial, marble, granite, mosaics, bronze and solar glass, stone or face brick vener , metal and glass panels, best glass	Plaster and drywall, paneling, vinyl wall finishes, marble, terrazzo , carpet	Best lighting and closed circuit TV, best plumbing and rest rooms	Package heat / AC
Good	Highly ornamental, marble, granite, best glass, brick vener , metal and glass panels, EIFS, sandwich panels, brick trim, good fenestration	Drywall and plaster, paneling, good partitions, carpet and vinyl	Good fluorescent ceiling panels, good outlets, adequate rest rooms	Package heat / AC
Average	Good brick, ornamental concrete, block, tilt-up, sandwich panels, good store type front with some trim	Plaster or drywall, acoustic tile, vinyl composition, some terrazzo , pavers or ceramic, good detail	Good lighting and outlets, adequate rest rooms	Package heat / AC
Low Cost	Brick, concrete, metal panels, stucco or siding, tilt-up, little trim	Plaster or drywall, vinyl composition, acoustic tile, few partitions	Minimum bank lighting, minimum rest room facilities	Package heat / AC

MODEL 162 - X ILLUSTRATIONS



MODEL 162 - X ILLUSTRATIONS



MODEL 171 - X SERVICE STATION - FULL SERVICE

These are commercial buildings located on properties that dispense fuel to motor vehicles, as well as provide repair, maintenance, and some sales. Full service stations generally have service bays, storage facilities, office or sales areas, and rest rooms. Service stations are typically constructed from masonry block or steel-framed, with enameled metal siding and an insulated roof. Interiors are typically plain enameled paint with fluorescent tube lighting in office and service areas. The structure may have ceiling mounted gas forced air or radiant electric heaters and roof mounted evaporative coolers.

The following components are for a complete full service station. The cost includes foundation, floor, framing, exterior wall, fenestration, garage doors, roof, electrical, and plumbing. Heating and/or cooling must be added if present.

Special Purpose Buildings (Composite component codes)

- YC** Masonry (SF)
- YA** Steel frame (SF)
- YB** Wood Frame (SF)

The components below are restricted to the 171 - X and 172 - X models. Although they are primarily used as an alternate method to build a 171 - X model, they may also be used for 172 - X.

Exterior Wall / masonry

- MP** Brick (SFW)
- MQ** Concrete block (SFW)
- MS** Steel panels (SFW)

Floor Structure

- EX** Concrete slab (SF)
- EY** Wood floor structure (SF)

Exterior Wall / single wall construction

- MSR** Steel and glass, painted
- MSP** Steel and glass, porcelainized

Electrical

- LC** Basic power service (EA, includes 2 circuits)
- LD** Additional circuits (EA)

NOTE: In order to derive the correct amount of depreciation, all yard improvements associated with the service station must be listed under the 171 - X model. Do not use model 101, commercial yard improvements.

The following miscellaneous components may be used with models 171 - X, 172 - X, 173 - X, 174 - X, and 175 - X.

Yard Improvements

- PCI** Concrete Islands (SF of Island)
- SIO** Service Island Office (SF of office 25 to 300 SF size)
- CPS** Steel Canopy (SF of covered area)
- CPW** Wood Canopy (SF of area covered)

TYPE	EXTERIOR WALLS	INTERIOR FINISH	PLUMBING / ELECTRICAL	HEATING/COOLING
Excellent	Best steel or brick, masonry trim, good fenestration, garage doors	Good finish, best workmanship, many built-in features, tire racks, etc.	Good commercial plumbing fixtures, good electrical	Package AC
Good	Good steel or brick, sectional doors, good sash, large overhangs	Ranch or suburban style, tiled rest rooms, good office	Average commercial fixtures, adequate interior circuits	Space heaters / wall AC
Average	Average painted steel or block, little trim, small overhangs	Present day station, small office, storage, rest rooms	Low-cost commercial plumbing fixtures, standard electrical	Space heaters / wall AC
Low Cost	Painted steel, siding or stucco, inexpensive sash and doors or gates	Older station, minimum finishes, few built-in items	Residential type fixtures, minimum interior electrical	Space heaters / evaporative cooling

MODEL 171 - X ILLUSTRATIONS



MODEL 171 - X ILLUSTRATIONS



MODEL 172 - X SERVICE STATION – SELF-SERVICE

These are structures designed primarily for self-dispensing fuel to motor vehicles. They typically have a service island, office, and drive surface.

The components below are restricted to the 171 - X and 172 - X models. Although they are primarily used as an alternate method to build a 171 - X model, they may also be used for 172 - X.

Note: In order to derive the correct amount of depreciation, all yard improvements must be listed under the 172 - X model. Do not use 101, Commercial Yard Improvements.

Exterior Wall / masonry

- MP** Brick (SFW)
- MQ** Concrete block (SFW)
- MS** Steel panels (SFW)

Exterior Wall / single wall construction

- MSR** Steel and glass, painted
- MSP** Steel and glass, porcelainized

Floor Structure

- EX** Concrete slab (SF)
- EY** Wood floor structure (SF)

Electrical

- LC** Basic power service (EA, includes 2 circuits)
- LD** Additional circuits (EA)

The following miscellaneous components may be used with models 171 - X, 172 - X, 173 - X, 174 - X, and 175 - X.

Yard Improvements

- PCI** Concrete Islands (SF of Island)
- SIO** Service Island Office (SF of office 25 to 300 SF size)
- CPS** Steel Canopy (SF of covered area)
- CPW** Wood Canopy (SF of area covered)

MODEL 172 - X ILLUSTRATIONS



MODEL 172 - X ILLUSTRATIONS



MODEL 173 - X CAR WASH / DRIVE-THROUGH

Small, enclosed, automated vehicle wash, sometimes associated with a service station. Generally coin-operated and unattended, where the customer stays in the vehicle and the vehicle is pulled through the wash line.

Construction is typically unfinished masonry block walls with concrete drained floors and a low or flat pitch built-up or metal roof. Plumbing and electrical service are sufficient.

The components listed below are restricted to this model:

Special Purpose Buildings (20) (Composite Component Codes)

YWD	Car Wash Masonry (SF)
YWE	Car Wash Porcelainized Steel (SF)
YWF	Car Wash Steel (SF)
YWG	Car Wash Wood Frame / Stucco (SF)

The following miscellaneous components may be used with models 171 - X, 172 - X, 173 - X, 174 - X, and 175 - X:

Yard Improvements (36)

SIO	Service Island Office (SF of office) 25 to 300 SF office size
CPS	Steel Canopy (SF of area covered)
CPW	Wood Canopy (SF of area covered)

NOTE: In order to derive the correct amount of depreciation, all yard improvements must be listed under the 171, 172, 173, 174, or 175 model. Do not use 101, Commercial Yard Improvements.

MODEL 173 - X ILLUSTRATIONS



MODEL 173 - X ILLUSTRATIONS



MODEL 174 - X CAR WASH / AUTOMATIC

A large, attended, automated car wash with a mechanical line. Special purpose building components include the cost for the building shell, slab, floor drains, basic electrical, lighting and water service, finished office/sales area, locker area and restrooms and equipment, but not heating and cooling.

The components listed below are restricted to this model:

Special Purpose Buildings (20) (Composite Component Codes)

- YWJ** Car Wash, Masonry (SF)
- YWK** Car Wash, Porcelainized Steel (SF)
- YWL** Car Wash, Steel (SF)
- YWM** Car Wash, Wood Frame / Stucco (SF)

Yard Improvements (36) Restricted to This Model

- UWC** Car Wash Canopy (SF)
- UWA** Car Wash Decorative Lamps (EA)
- UWB** Car Wash Ornamental Pylons (EA)

The following miscellaneous components may be used with models 171 - X, 172 - X, 173 - X, 174 - X, and 175 - X:

Yard Improvements (36)

- SIO** Service Island Office (SF of office) 25 to 300 SF office size
- CPS** Steel Canopy (SF of area covered)
- CPW** Wood Canopy (SF of area covered)

NOTE: In order to derive the correct amount of depreciation, all yard improvements must be listed under the 171, 172, 173, 174, or 175 model. Do not use 101, Commercial Yard Improvements.

MODEL 174 - X ILLUSTRATIONS



MODEL 174 - X ILLUSTRATIONS



MODEL 175 - X CAR WASH / SELF-SERVE

Car / Truck / RV washing facility, sometimes associated with a service station. Designed for efficiency and function rather than aesthetics. Coin-operated, spray wand washing units, usually unattended, but may have small supply / maintenance room. Easy access in and out of bays, with some parking areas that may have canopy cover.

Masonry block partition walls, concrete drained floors, flat or low pitch built-up or metal roof. Lower grades may have pre-engineered metal roof and roof supports and painted metal partition walls. Sufficient plumbing and electrical service for the quality of the improvement.

The components listed below are restricted to this model:

Exterior Wall (6)

- MWA** Car Wash, Masonry Partition (SFW or partition area)
- MWB** Car Wash, Steel Partition (SFW or partition area)
- MWC** Car Wash, Wood Frame / Stucco (SFW or partition area)

Roof Structure (9)

- QWA** Car Wash, Steel (SF)
- QWB** Car Wash, Wood (SF)

Floor Structure (11)

- EWA** Car Wash, Asphalt (SF)
- EWB** Car Wash, Concrete (SF)

Special Purpose Buildings (20) (Composite Component Codes)

- YWA** Car Wash Equipment Room, Masonry (SF)
- YWB** Car Wash Equipment Room, Porcelainized Steel (SF)
- YWC** Car Wash Equipment Room, Wood Frame / Stucco (SF)

The following miscellaneous components may be used with models 171 - X, 172 - X, 173 - X, 174 - X, and 175 - X:

Yard Improvements (36)

- SIO** Service Island Office (SF of office) 25 to 300 SF office size
- CPS** Steel Canopy (SF of area covered)
- CPW** Wood Canopy (SF of area covered)

NOTE: In order to derive the correct amount of depreciation, all yard improvements must be listed under the 171, 172, 173, 174, or 175 model. Do not use 101, Commercial Yard Improvements.

MODEL 175 - X ILLUSTRATIONS



MODEL 175 - X ILLUSTRATIONS



MODEL 176 - X MINI-LUBE GARAGE

Mini-Lube buildings are garages designed for quick maintenance, lubrication, and oil changes, and may have drive-through bays. They typically have full basements or extensive pit areas, customer waiting rooms, and small office and storage areas.

TYPE	EXTERIOR WALLS	INTERIOR FINISH	PLUMBING / ELECTRICAL	HEATING/COOLING
Average	Good masonry, frame / stucco or pre-engineered panels, roll-up doors	Painted walls, slab, some partitions, waiting room, acoustic tile	Adequate lighting and plumbing, service outlets	Space heaters / evaporative cooling
Low Cost	Block, cheap brick, tilt-up, stucco or siding, pre-engineered frame with metal siding	Painted walls, slab, few partitions, small office area	Minimum lighting and plumbing, service outlets	Space heaters / evaporative cooling

MODEL 176 - X ILLUSTRATIONS



MODEL 176 - X ILLUSTRATIONS



MODEL 178 - X**AUTOMOTIVE REPAIR**

Automotive repair buildings are designed primarily for vehicle repair and maintenance. They may be any class of construction. Typically they have small office areas (less than 20% of total square footage) with plaster or drywall partitions. Floors are concrete with resilient covering in office areas. Exterior walls generally have large openings with either overhead or sliding doors and minimal [fenestration](#).

TYPE	EXTERIOR WALLS	INTERIOR FINISH	PLUMBING / ELECTRICAL	HEATING/COOLING
Excellent	Steel or concrete frame, brick, decorative block or concrete panels	Good offices and supply rooms, good fleet-municipal type	Good electrical, lighting and service outlets, good rest rooms	Package heating / cooling
Good	Brick, decorative block, concrete panels, good siding, frame / stucco, or sandwich panels	Finished office, painted walls, some partitions	Adequate lighting and service outlets, adequate rest rooms	Space heaters / evaporative cooling
Average	Masonry bearing walls, wood siding or frame / stucco, metal single wall	Unfinished, small finished office, small supply area	Adequate lighting and service outlets, small rest rooms	Space heaters / evaporative cooling
Low Cost	Light masonry bearing walls, cheap siding or frame / stucco, light pre-engineered	Unfinished, small partitioned office area, concrete floor	Minimum lighting and plumbing	Space heaters / evaporative cooling

MODEL 178 - X ILLUSTRATIONS



MODEL 178 - X ILLUSTRATIONS



MODEL 179 - X AUTO PARTS AND SERVICE

Auto parts and service buildings are designed for both sales and service with display rooms, office, storage, and repair space commensurate with the quality of the building. These are combination retail store (with storefront and finish) and garage. Average quality improvements will have a sales area that is approximately 20% to 30% of the total floor area. Lighting in the sales area is similar to store lighting in both quality and fixture type. Service areas have industrial lighting and fixtures.

TYPE	EXTERIOR WALLS	INTERIOR FINISH	PLUMBING / ELECTRICAL	HEATING/COOLING
Good	Brick, block, siding, veneer, good storefront	Good store finish in sales, good garage finish in balance	Good store illumination, good rest rooms	Package heating / cooling in sales, space heaters / evaporative coolers in garage
Average	Block, frame / stucco, or siding, sandwich panels, typical storefront	Store finish in sales, garage finish in balance	Average store lighting and rest rooms	Package heating / cooling in sales, space heaters / evaporative coolers in garage
Low Cost	Block, frame / metal or single wall, simple storefront	Minimum finish in sales, garage finish in balance	Minimum lighting and plumbing	Space heaters / evaporative coolers in both sales and garage areas

MODEL 179 - X ILLUSTRATIONS



MODEL 179 - X ILLUSTRATIONS



MODEL 201 - X RESTAURANT - FULL SERVICE

These are structures designed for the preparation, service, and sale of food and beverages. Included in the range of structures are cafeterias, bars, and taverns where the design is of a restaurant type. The lower quality improvements may have stools at a counter, tables, booths, or a mixture. A separate lounge area may be found in the higher quality improvements, as will custom decor, special lighting, and high quality fixtures. Food storage and preparation areas and separate office areas are typical, but lowest quality structures may not have separate office space.

Included in interior construction component **HA** costs are interior partition wall framing, drywall, wall finishing or wall coverings, closets, casework, trim and hardware, doors, work counters, shelving and cabinetry, built-in refrigerated storage boxes and restroom accessories all installed under the general building contract.

All furnishings, fixtures and equipment which is often installed and in some cases may become part of the real property, but typically not part of the general contract, are not included in HA costs. This would include the kitchen and bar equipment and fixtures and all food service counters, booths and seating. The rough-in work for these items is normally performed under the general contract, but the equipment is usually purchased and installed by a specialty contractor under separate contract. All movable equipment, such as chairs, tables, utensils and linens would never be included in HA costs.

*Note: By using HA or **HANC**, the appraiser may or may not include the cost of walk-in cooler boxes from a segregated system listing. The square foot component for this model does not include the cost of walk-in cooler boxes. In a square foot listing, use component **HSFC** (built-in coolers) to add the cooler cost. For more information about walk-in cooler boxes, see [Volume I, Appendix A](#).*

- Lower quality improvements will have little exterior finish, small entrances, minimal interior partitioning, and finishes.
- Average quality units will have individual deviations from a standard design, average quality fixtures and design.
- Good quality structures will have better quality exterior ornamentation, with good quality interior finishes.
- High quality units will be larger, with substantial exterior embellishment. Interiors will be of high quality construction with excellent finishes

TYPE	EXTERIOR WALLS	INTERIOR FINISH	PLUMBING / ELECTRICAL	HEATING/COOLING
Excellent	Individual design, brick, brick veneer, good metal, glass, ornamentation	Typically best chain, good plaster, ceramic pavers throughout	Special lighting, tiled rest rooms, good fixtures	Complete H.V.A.C.
Good	Brick, concrete or metal and glass panels, good stucco or siding, some ornamentation	Typical chain and better large stores, plaster, ceramic, terrazzo , vinyl tile	Good lighting, rest rooms with good fixtures, tile	Complete H.V.A.C.
Average	Brick or concrete, stucco or siding, plain front	Drywall, paneling, acoustic tile, pavers, vinyl composition, large eating/play area	Adequate lighting and outlets, small rest rooms	Complete H.V.A.C.
Low Cost	Cheap brick or block, stucco or siding, small entry	Low cost prep area, minimum finish, asphalt tile	Minimum plumbing and lighting	Forced air heat, evaporative cooling

MODEL 201 - X ILLUSTRATIONS



MODEL 201 - X ILLUSTRATIONS



MODEL 201 - X ILLUSTRATIONS



MODEL 201 - X ILLUSTRATIONS



MODEL 202 - X RESTAURANT - FAST FOOD

These are structures designed for the preparation, service, and sale of food and beverages where the consumption or dining area is limited in relation to the preparation area. Drive-up windows commensurate with the quality of the structure are included in the wall cost. The average improvement will have some overhang, but no large separate canopies or carports. Dining area is normally less than 45% of total building area. Suitable office and rest room facilities are included. For buildings with larger dining areas, the full service restaurant model (201 - X) is more appropriate.

Note: By using [HA](#) or [HANC](#), the appraiser may or may not include the cost of walk-in cooler boxes from a segregated system listing. The square foot component for this model does not include the cost of walk-in cooler boxes. In a square foot listing, use component [HSFC](#) (built-in coolers) to add the cooler cost. For more information about walk-in cooler boxes, see [Volume I, Appendix A](#).

- Lower quality improvements will be plain, small entrances, built to minimum code specifications.
- Average quality units will be modeled from a standard design, typical of a franchise, average quality fixtures and design.
- Good quality structures will have individual variations on a standard design with good quality interior finishes.
- High quality units will be larger, with some individual embellishment. Interiors will be of best quality construction with good finishes.

TYPE	EXTERIOR WALLS	INTERIOR FINISH	PLUMBING / ELECTRICAL	HEATING/COOLING
Excellent	Individual design, brick, brick veneer, good metal, glass, ornamentation	Typically best chain, good plaster, ceramic pavers throughout	Special lighting, tiled rest rooms, good fixtures	Complete H.V.A.C.
Good	Brick, concrete or metal and glass panels, good stucco or siding, some ornamentation	Typical chain and better large stores, plaster, ceramic, terrazzo , vinyl tile	Good lighting, rest rooms with good fixtures, tile	Complete H.V.A.C.
Average	Brick or concrete, stucco or siding, plain front	Drywall, paneling, acoustic tile, pavers, vinyl composition, large eating/play area	Adequate lighting and outlets, small rest rooms	Complete H.V.A.C.
Low Cost	Cheap brick or block, stucco or siding, small entry	Low-cost prep area, minimum finish, asphalt tile	Minimum plumbing and lighting	Forced air heat, evaporative cooling

MODEL 202 - X ILLUSTRATIONS



MODEL 202 - X ILLUSTRATIONS



MODEL 202 - X ILLUSTRATIONS



MODEL 202 - X ILLUSTRATIONS

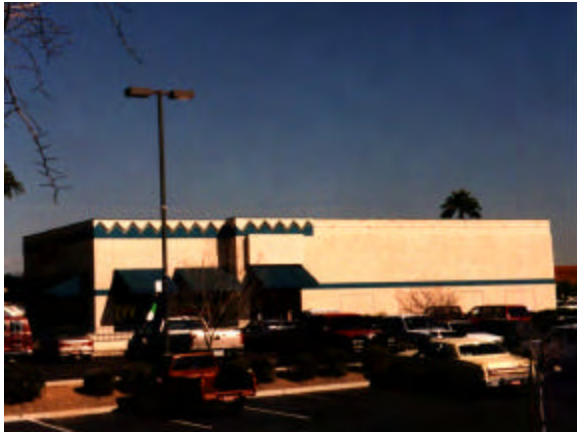

MODEL 203 - X COCKTAIL LOUNGE

These are structures designed for the service and sale of alcoholic beverages and limited food service. Some dance floor and or stage area is typical, as are separate areas for receiving and storage, office space, and food preparation.

Note: By using [HA](#) or [HANC](#), the appraiser may or may not include the cost of walk-in cooler boxes from a segregated system listing. The square foot component for this model does not include the cost of walk-in cooler boxes. In a square foot listing, use component [HSFC](#) (built-in coolers) to add the cooler cost. For more information about walk-in cooler boxes, see [Volume I, Appendix A](#).

- Lower quality improvements will be very plain, small game or dance floor areas, low-cost finishes.
- Average quality units will have some exterior trim, typical bar finishes, dance or good game floor, small performance area.
- Good quality structures will have some exterior ornamentation, good bar, dance floor, small stage.
- High quality units will have individual design, high quality detail, full stage, dance area, best acoustics, deluxe quality.

TYPE	EXTERIOR WALLS	INTERIOR FINISH	PLUMBING / ELECTRICAL	HEATING/COOLING
Excellent	Individual design, highly ornamental finishes	Drywall or plaster, good carpet and tile, decorated interior, full stage, dance floor, best acoustics	Special lighting effects, good plumbing, small kitchen	Package heating / cooling
Good	Brick, concrete or metal and glass panels, stucco or siding, some ornamentation	Drywall and plaster, some ornamentation, decorated interior, stage, small dance floor, good carpet, vinyl and ceramic floors	Good lighting and service outlets, tiled rest rooms, limited food prep	Package heating / cooling
Average	Brick, block, stucco or siding, plain building and front, little trim	Typical bar finishes, carpet, vinyl composition, dance or game floor, good performance platform	Adequate lighting and outlets, small rest rooms	Package heating / cooling
Low Cost	Cheap brick or block, stucco or siding, very plain	Low-cost finishes, game or dance floor, small performance platform, small office and storage	Minimum lighting, minimum rest room facilities	Forced air heating, evaporative cooling

MODEL 203 - X ILLUSTRATIONS



MODEL 203 - X ILLUSTRATIONS



MODEL 204 - X BAR / TAVERN

These are buildings designed for the preparation and service of beverages and some food. Areas for preparation, service, consumption, receiving and storage, and rest rooms are included. An office area commensurate with the improvement is also typical. Theme bars or taverns may have special ornamentation that may or may not be considered as part of the real property.

Exterior construction is typically masonry block, with a flat to low pitch roof, built-up or composition shingle, and minimal fenestration. Some franchise operations may have variations on a standard design. Good bars or taverns normally have food service facilities. They also have suitable office areas and all necessary plumbing and electrical connections for kitchen equipment.

Note: By using [HA](#) or [HANC](#), the appraiser may or may not include the cost of walk-in cooler boxes from a segregated system listing. The square foot component for this model does not include the cost of walk-in cooler boxes. In a square foot listing, use component [HSFC](#) (built-in coolers) to add the cooler cost. For more information about walk-in cooler boxes, see [Volume I, Appendix A](#).

- Lower quality improvements will be very plain, small offices, minimal storage, and cheap finishes.
- Average quality units will have little trim, average interior finish.
- Good quality structures will have some exterior ornamentation, with good quality interior finishes.
- High quality units will be larger, with individual exterior embellishment. Interiors will be of high quality construction with excellent finishes.

TYPE	EXTERIOR WALLS	INTERIOR FINISH	PLUMBING / ELECTRICAL	HEATING/COOLING
Excellent	Individual design, highly ornamental finishes	Drywall or plaster, good carpet and tile, decorated interior	Good lighting and outlets, good plumbing, food prep	Package heating / cooling
Good	Brick, concrete or metal and glass panels, stucco or siding, some ornamentation	Drywall and plaster, some ornamentation, good carpet, vinyl and ceramic floors	Good lighting and service outlets, tiled rest rooms, limited food prep	Package heating / cooling
Average	Brick, block, stucco or siding, plain building and front, little trim	Typical neighborhood bar, carpet, vinyl composition, small game area	Adequate lighting and outlets, small rest rooms	Package heating / cooling
Low Cost	Cheap brick or block, stucco or siding, very plain	Low-cost finishes, small office and storage	Minimum lighting, minimum rest room facilities	Forced air heating, evaporative cooling

MODEL 204 - X ILLUSTRATIONS



MODEL 204 - X ILLUSTRATIONS



MODEL 205 - X TRUCK STOP

These buildings are of multipurpose design to include convenience store, food service, shower and toilet, game and restroom facilities for highway travelers and truckers. Good facilities include the typical coffee shop operation, while the average quality includes the limited lower priced fast food franchise operation. Lighting and plumbing, although adequate to service the operation, are not excessive or ornate.

Since truck stops have higher requirements for heating, cooling and ventilation use component [KYA](#) (Complete HVAC) in restaurant and kitchen areas.

The following are not included in the costs: Kitchen equipment, restaurant or convenience store fixtures, furnishings and signs.

Note: By using [HA](#) or [HANC](#), the appraiser may or may not include the cost of walk-in cooler boxes from a segregated system listing. The square foot component for this model does not include the cost of walk-in cooler boxes. In a square foot listing, use component [HSFC](#) (built-in coolers) to add the cooler cost. For more information about walk-in cooler boxes, see [Volume I, Appendix A](#).

- Lower quality improvements will have little exterior finish, small entrances, minimal interior partitioning, and finishes.
- Average quality units will have individual deviations from a standard design, average quality fixtures and design.
- Good quality structures will have better quality exterior ornamentation, with good quality interior finishes.
- High quality units will be larger, with substantial exterior embellishment. Interiors will be of high quality construction with excellent finishes

TYPE	EXTERIOR WALLS	INTERIOR FINISH	PLUMBING / ELECTRICAL	HEATING/COOLING
Excellent	Brick, concrete, EIFS, metal and glass panels, ornamentation	Good coffee shop, retail, separate rest area, shower room	Good lighting, showers, restrooms and kitchen with good fixtures	Very good comp. H.V.A.C. in resturant/kitchen areas
Good	Decorative block, brick veneer, good siding, tilt-up, good storefront, lobby	Full-service food seating, retail, rest and game rooms	Good electrical and plumbing, showers, full kitchen	Complete H.V.A.C. in resturant/kitchen areas
Average	Concrete block, tilt-up, stucco, steel frame, or siding, plain storefront entry	Fast food service, small convenience store, rest area	Adequate electrical, plumbing, walk-in box storage	Complete H.V.A.C. in resturant/kitchen areas

MODEL 205 - X ILLUSTRATIONS



MODEL 205 - X ILLUSTRATIONS



MODEL 210 - X**MEDICAL - DENTAL CLINIC, FIRST FLOOR PARKING**

These are buildings designed for medical and or dental services on an outpatient basis. They include a reception area/lobby, as well as individual examination and treatment rooms. These are similar to the Medical - Dental Clinic model (211 - X) but have a first floor open for parking and tend to be less than 4 stories rather than high - rise structures.

Floor coverings include carpet, resilient flooring, or ceramic tile. Ceilings are typically acoustic tile and most include some high intensity fluorescent lighting. Better quality facilities will have built-in cabinetry. Interior costs include the lead-lined walls associated with x-ray facilities.

Individual treatment rooms may have plumbing and sinks, while rest room facilities generally will be adequate to the number of staff.

- Lower quality improvements will be very plain, minimal partitioning, and low-cost fixtures.
- Average quality units will have few architectural embellishments, average quality fixtures and design.
- Good quality structures will have some exterior ornamentation, with good quality interior finishes.
- High quality units will be larger with individual exterior embellishment. Interiors will be of high quality with many partitions and excellent fixtures.

Listing techniques for these structures are found in [Appendix A: Listing Procedures for Office Buildings with First Floor Parking \(152 - X\)](#).

TYPE	EXTERIOR WALLS	INTERIOR FINISH	PLUMBING / ELECTRICAL	HEATING/COOLING
Excellent	Best metal, brick or block backup, or brick veneer, solar glass, concrete or steel frame, masonry, studs and steel columns, bar or web joists, EIFS	Drywall or plaster, good veneers, good carpet and tile, vinyl wall coverings	Luminous ceilings, power and X-ray outlets, best plumbing	Hot and chilled water (zoned)
Good	Good metal and solar glass, brick, concrete or metal and glass panels, concrete or steel frame, masonry, or concrete panels, or best stucco on wood frame, some ornamentation	Drywall and plaster, acoustic tile, carpeting, vinyl composition	High intensity lighting, X-ray outlets, good plumbing, lab	Hot and chilled water (zoned)
Average	Brick, block, stucco or siding, metal and glass, concrete panels, steel or concrete frame or bearing walls, plain building and front, little trim	Plaster or drywall, acoustic tile, vinyl composition	Adequate lighting, power, and plumbing, X-ray rooms	Warm and cool air (zoned)
Low Cost	Brick or block, steel or aluminum, concrete or steel frame, stucco or siding, very plain, small lobby	Low-cost finishes and partitions, acoustic tile, asphalt tile	Minimum lighting and plumbing, few extras	Package AC

MODEL 210 - X ILLUSTRATIONS



MODEL 210 - X ILLUSTRATIONS



MODEL 211 - X**MEDICAL - DENTAL CLINIC**

These are buildings designed for medical and or dental services on an outpatient basis. They include a reception area/lobby, as well as individual examination and treatment rooms.

Floor coverings include carpet or resilient flooring, or ceramic tile. Ceilings are typically acoustic tile and most include some high intensity fluorescent lighting. Better quality facilities will have built-in cabinetry. Interior costs include the lead-lined walls associated with x-ray facilities.

Individual treatment rooms may have plumbing and sinks, while restroom facilities generally will be adequate to the number of staff.

- Lower quality improvements will be very plain, minimal partitioning, and low-cost fixtures.
- Average quality units will have few architectural embellishments, average quality fixtures and design.
- Good quality structures will have some exterior ornamentation with good quality interior finishes.
- High quality units will be larger, with individual exterior embellishment. Interiors will be of high quality with many partitions and excellent fixtures.

TYPE	EXTERIOR WALLS	INTERIOR FINISH	PLUMBING / ELECTRICAL	HEATING/COOLING
Excellent	Best metal, brick or block backup, or brick veneer, solar glass, steel frame, masonry, studs and steel columns, bar or web joists, EIFS	Drywall or plaster, good veneers, good carpet and tile, vinyl wall coverings	Luminous ceilings, power and x-ray outlets, best plumbing	Hot and chilled water (zoned)
Good	Good metal and solar glass, brick, concrete or metal and glass panels, steel frame, masonry, or concrete panels, or best stucco on wood frame, some ornamentation	Drywall and plaster, acoustic tile, carpeting, vinyl composition	High intensity lighting, x-ray outlets, good plumbing, lab	Hot and chilled water (zoned)
Average	Brick, block, stucco or siding, metal and glass, concrete panels, steel or concrete frame or bearing walls, plain building and front, little trim	Plaster or drywall, acoustic tile, vinyl composition	Adequate lighting, power, and plumbing, x-ray rooms	Warm and cool air (zoned)
Low Cost	Brick or block, steel or aluminum, light frame, stucco or siding, very plain, small lobby	Low-cost finishes and partitions, acoustic tile, asphalt tile	Minimum lighting and plumbing, few extras	Package AC

MODEL 211 - X ILLUSTRATIONS



MODEL 211 - X ILLUSTRATIONS



MODEL 212 - X**VETERINARY CLINIC**

These are buildings designed for medical and surgical care and treatment of small animals. Costs do not include cages and runs or open shelters. Interior costs include the lead-lined walls associated with x-ray facilities.

Floor coverings include vinyl composition, carpet or ceramic tile. Ceilings are typically acoustic tile with fluorescent overhead lighting.

Plumbing and electrical will be commensurate with the quality of the structure.

- Lower quality improvements will be very plain, minimal partitioning, and low-cost fixtures.
- Average quality units will have few architectural embellishments, average quality fixtures and design.
- Good quality structures will have some exterior ornamentation with good quality interior finishes.
- High quality units will be larger, with individual exterior embellishment. Interiors will be of high quality with many partitions and excellent fixtures.

TYPE	EXTERIOR WALLS	INTERIOR FINISH	PLUMBING / ELECTRICAL	HEATING/COOLING
Excellent	Face brick, block or concrete, good entrance and trim	Plaster ceramic, vinyl and carpet finishes, indoor exercise facilities	Luminous ceilings, power and x-ray outlets, best plumbing	Hot and chilled water (zoned)
Good	Face brick, ornamental block, good trim and fenestration	Drywall and plaster, vinyl, good lab and x-ray facilities	High intensity lighting, x-ray outlets, good plumbing, lab	Hot and chilled water (zoned)
Average	Brick, stucco or siding, insulated sandwich panels or metal with finished interior	Drywall or plaster, vinyl, laboratory and x-ray facilities	Adequate lighting, power, and plumbing, x-ray rooms	Warm and cool air (zoned)
Low Cost	Block or tilt-up, stucco or siding, metal on light frame, very plain	Drywall, some asphalt tile floor	Minimum lighting and plumbing, few extras	Package AC

MODEL 212 - X ILLUSTRATIONS



MODEL 212 - X ILLUSTRATIONS



MODEL 213 - X HOSPITAL

These are buildings designed for complete health care, which include a number of different health services within one building. Areas for diagnosis, surgery, delivery, emergency care, patient care, administration, and pharmacies are typical. The amount of actual space associated with any or all of these areas varies with the size of the building and the number of people serviced by the hospital.

Lower quality hospitals have large ward areas while higher quality ones have more private rooms. The area per bed ranges between 600 and 1600 square feet depending on quality.

Exterior finishes may include marble, granite, concrete, or metal and glass panels in the better qualities and brick, block or masonry veneers with little ornamentation in the lower quality structures.

Interior finishes are plaster or drywall, with suspended acoustical ceilings. Floor finishes include vinyl composition, ceramic tile or some other type of resilient floor covering. Signal systems, special oxygen piping and pneumatic conveyers are typically found and will conform to the quality of the structure.

Plumbing and electrical will be commensurate with the quality of the structure.

Costs for the square foot system base component and the segregated system interior construction component HA for hospitals includes Group 1 equipment but not Groups 2 & 3.

Group 1 equipment includes: permanent equipment, installed in or attached to the building during construction and would, for example, include such items as built-in shelves, cabinets and nursing stations, i.e. all items which are normally part of the general contract. Typically, this would include the following, depending on quality:

1. Oxygen system, tubing and outlet at each patient's bed.
2. Nurse call stations, including conduit to each patient's bed.
3. Telecommunications, audio-visual wiring, but not equipment.
4. Sufficient doors with a requirement of one-hour rating minimum to extreme heat, and construction within stringent fire prevention codes.
5. Conductive floor systems in Operating, Obstetrical and Emergency Rooms.
6. Steam boiler and piping necessary to operate autoclaves, but not the autoclaves themselves.
7. Separate ventilation systems for Nursery, Operating and Delivery Rooms, but not the special filtering equipment.
8. Acoustically treated ceiling, doors, walls, and floors in Electro-encephalogram Room.
9. Isolated wiring system of the Intensive Care Unit, excluding extra conduit for monitors, but none of the equipment.
10. Narcotic vault in Pharmacy.
11. Substantial plumbing and wiring for use of a wide range of equipment in Laboratory, but not Laboratory equipment.
12. Lead shielding and extra support built into walls, ceilings and floors of the X-ray Rooms, Also, the higher voltage electrical system to handle the X-ray equipment, but no equipment.
13. The isolated high cost electrical system and the lead lining of the Operating Room.
14. The insulation requirements of the built-in coolers and freezers in the hospital kitchen.
15. Emergency power generating equipment.

Group 2 equipment is often installed and becomes part of the real property, but typically not part of the general contract, and is not included in the costs. This group would generally include permanent surgical lighting and laminar flow filter systems. The rough-in work for these items is normally performed under the general contract, but the equipment is usually purchased and installed by the manufacturer or his representative. This group would relate closely to what is normally considered trade fixtures in a commercial occupancy such as a retail store.

Group 3 is all movable chattel, such as linen, beds, furniture, kitchen utensils, typewriters, etc. and would never be included in the costs.

TYPE	EXTERIOR WALLS	INTERIOR FINISH	PLUMBING / ELECTRICAL	HEATING/COOLING
Excellent	Marble, granite, best metal and glass, concrete, stone ashlar , highly decorative	Plaster, ceramic, vinyl, and tile wall finishes, best ceilings and floors	Oxygen, pneumatic conveyer, signal, much automation	Complete HVAC
Good	Brick, metal and glass, stone trim, brick vener , EIFS , good entrance and ornamentation	Drywall and plaster, best enamels or vinyl wall finishes, ceramic, vinyl or rubber tile floors	Signal system, oxygen piping, pneumatic conveyers	Complete HVAC
Average	Metal and glass, concrete, brick panels, good stucco or siding with brick or stone trim, little ornamentation	Drywall, acoustic ceilings, vinyl and ceramic floors, linoleum	Signal system, oxygen piping, adequate plumbing and heating	Complete HVAC
Low Cost	Concrete panels, brick, block, stucco or siding, little ornamentation, small entrance	Drywall, acoustic ceilings, vinyl composition, minimum detail	Signal systems, adequate plumbing and heating	Complete HVAC

MODEL 213 - X ILLUSTRATIONS



MODEL213 - X ILLUSTRATIONS



MODEL 214 - X**NURSING HOME**

These are buildings of hospital type construction which give nursing care. They are designed for bed care and or hotel and nursing care for ambulatory patients. They have treatment and therapy rooms, service and administration areas, nurses' stations and signaling systems commensurate with the overall quality of the building. They generally do not have surgical care or treatment areas.

Exterior and interior finishes are similar to hospitals in terms of materials.

- Lower quality improvements will be plain with smaller entrances and little embellishment.
- Average quality units will have some ornamentation and interior finishes commensurate with the quality of the building.
- Good quality structures will have better exterior ornamentation, good quality interior finishes.
- High quality units will have best exterior finishes, large entrances, highest quality interior finishes.

TYPE	EXTERIOR WALLS	INTERIOR FINISH	PLUMBING / ELECTRICAL	HEATING/COOLING
Excellent	Highly ornamental metal or concrete panels and glass, face brick, or stone	Plaster or drywall, vinyl and ceramic walls, carpet and vinyl floors	Signal system, therapy facilities, good lighting and plumbing	Hot and chilled water (zoned)
Good	Metal and glass, brick, stone trim, brick veneer, EIFS, good entrance and trim	Drywall and plaster, vinyl or enamel walls, vinyl floor, some carpet	Signal system, therapy facilities, good lighting and plumbing	Hot and chilled water (zoned)
Average	Brick, concrete, metal and glass, good stucco or wood siding with brick or stone trim, sandwich panels	Drywall or plaster, acoustic ceilings, vinyl composition	Signal system, therapy facilities, good lighting and plumbing	Warm and cool air (zoned)
Low Cost	Brick, block, tilt-up, little ornamentation, insulated metal panels, simple entrance	Drywall, painted walls, acoustic and asphalt tile	Adequate lighting and plumbing, minimum hospital facilities	Package AC, forced air

MODEL 214 - X ILLUSTRATIONS



MODEL 214 - X ILLUSTRATIONS



MODEL 215 - X**EMERGENCY MEDICAL DISPENSARY**

These structures are designed for emergency first aid medical treatment. Typically they do not have facilities for surgery, although the better qualities may have some small surgical capability. All types usually have some office space. Interior costs include the lead-lined walls associated with x-ray facilities.

Floor coverings may be ceramic tile or some other type of resilient floor finish. Lighting and plumbing are adequate for emergency first aid use.

- Average quality units will have few embellishments, average quality fixtures and design.
- Good quality structures will have some ornamentation, with good quality interior finishes.

TYPE	EXTERIOR WALLS	INTERIOR FINISH	PLUMBING / ELECTRICAL	HEATING/COOLING
Good	Brick or block, brick vener , best stucco or siding, good fenestration , some trim	Drywall or plaster, acoustic tile, vinyl composition, some ceramic	Good lighting and plumbing, first aid and overnight care	Package Heating / AC
Average	Brick, block, tilt-up, stucco, or siding, very plain	Drywall or plaster, acoustic tile, vinyl, composition, asphalt tile	Adequate lighting and plumbing for emergency first aid	Package Heating / AC

MODEL 215 - X ILLUSTRATIONS



MODEL 215 - X ILLUSTRATIONS



MODEL 216 - X**SURGICAL CENTER**

These are structures designed for outpatient or same day surgery facilities. They include clinical surgery, diagnostic, lab, administrative and public areas. Operating rooms on average represent 2.5% of the total floor area. Interior costs include the lead-lined walls associated with x-ray facilities.

Plumbing and electrical will be commensurate with the quality of the structure.

- Lower quality improvements will be very plain, minimum treatment facilities.
- Average quality units will have adequate lighting and plumbing for surgical facilities.
- Good quality structures will have good lighting and plumbing with some extras.
- High quality units will have best diagnostic and research facilities, best radiation therapy.

TYPE	EXTERIOR WALLS	INTERIOR FINISH	PLUMBING / ELECTRICAL	HEATING/COOLING
Excellent	Stone ashlar , best metal or concrete and glass panels	Plaster, ceramic or vinyl walls, ceramic, best ceilings and floors	Best diagnostic and research, best radiation therapy	Complete HVAC
Good	Brick, metal and glass, stone, good concrete, good entrance	Drywall or plaster, best enamels or vinyl walls, ceramic, vinyl, shielding	Good lighting and plumbing, small lab, some extras, good imaging	Complete HVAC
Average	Brick, concrete, metal and glass, EIFS , ornamental stucco, little ornamentation	Plaster or drywall, acoustic ceilings, vinyl or tile, some carpet	Adequate lighting and plumbing for surgical facilities	Complete HVAC
Low Cost	Block, brick, or tilt-up, stucco or siding, metal on light frame, insulated panels, very plain	Drywall or plaster, or metal, acoustic tile ceilings, vinyl composition, minimum extras	Minimum treatment facilities, dialysis, some diagnostic	Complete HVAC

MODEL 216 - X ILLUSTRATIONS



MODEL 216 - X ILLUSTRATIONS



MODEL 220 - X**MORTUARY**

These buildings include the chapel, stained glass windows, and any laboratory facilities commensurate with the general quality. Generally, the better qualities include some living area, and may have a residential exterior that conforms to the general neighborhood.

Vehicular garages should be priced separately.

- Lower quality mortuaries will be plain with minimum service functions.
- Average quality mortuaries will have some trim, a good entrance and drive, and adequate facilities.
- Good quality structures will have good exterior detail, good entrance and drive, good plumbing, electrical and lab.
- High quality mortuaries will have highly ornamental exterior embellishment, interiors will be of high quality with good detail and millwork.

TYPE	EXTERIOR WALLS	INTERIOR FINISH	PLUMBING / ELECTRICAL	HEATING/COOLING
Excellent	Stone, face brick, or brick veneer, highly ornamental	Plaster, terrazzo, carpet, hardwood, good millwork and detail	Good electrical, plumbing fixtures, tiled rest rooms, lab	Warm and cool (zoned)
Good	Face brick, some trim, good exterior detail	Plaster or drywall, hardwood or carpet, good finishes and detail	Good electrical, plumbing fixtures, tiled rest rooms, lab	Warm and cool (zoned) or heat pump
Average	Brick or block, stucco or siding, sandwich panels, some trim, good entrance and drive	Exposed block, plaster or drywall, carpet, acoustic ceilings, vinyl composition	Adequate lighting, plumbing, lab, incinerator	Package AC
Low Cost	Block, stucco or siding, metal on pole frame, very plain	Plain, minimum service functions	Minimum lighting and plumbing	Forced air

MODEL 220 - X ILLUSTRATIONS



MODEL 220 - X ILLUSTRATIONS



MODEL 251 - X THEATER, WALK-IN

These are structures designed for showing films, with minimal or no stage structure. Newer construction may have many individual "theaters" inside the building which show different films simultaneously. Some new complexes contain twenty or more of these theaters. One ticket booth, a concession stand, and rest rooms to accommodate the patrons are standard.

Exterior is normally concrete block or block and stucco, with the more expensive structures having finer custom treatment on the front facade.

Interior is commensurate with the quality of the building. Differences in quality are generally found in the interior. Higher quality theaters will have special lighting and sound systems, some stage facilities, custom finishes, and good detail. Lower quality structures will have plain interiors typical of the minimum multiplex facility.

TYPE	EXTERIOR FINISH	INTERIOR FINISH	PLUMBING/ ELECTRICAL	HEATING/ COOLING
Excellent	Top design, best materials, very elaborate entrance and lobby	Cinema stages, ornamental interior, carpeting, tile, special finishes, acoustic design, high cost lobby finishes	High quality specialty lighting, best sound systems, good plumbing	Warm and cool air (zoned)
Good	Face brick, block, stone, terra cotta, ornamental entrance and lobby	Ornamental interior, carpeting, some stage ornamentation, carpeting, tile	Good lighting, sound systems, and plumbing	Warm and cool air (zoned)
Average	Brick, block, concrete, stucco, some ornamentation, good entrance, masonry sound walls	Plaster or gypsum, suspended ceiling, stepped floor, carpeted lobby	Adequate lighting, good sound and plumbing	Warm and cool air (zoned)
Low Cost	Low-cost block, brick, wood or tilt-up concrete, very plain, acoustic sound walls	Painted masonry, very plain, minimum multiplex cinema facility	Minimum code, sound per screen	Forced air

MODEL 251 - X ILLUSTRATIONS



MODEL 251 - X ILLUSTRATIONS



MODEL 252 - X THEATER, DRIVE-IN

These facilities are designed for outdoor viewing of motion pictures from the patron's motor vehicle. Many drive-in theaters will be mixed in quality and will vary greatly depending on size and type of screen and what service facilities are provided.

All site improvements are picked up as ADD items. The projection / concession building is listed by the appropriate model.

Use the following special drive-in components to list the site improvements. Use site preparation (BC) for the total square footage of the parking area.

DTB	Drive-in theater, car speaker post (EA)
DTC	Drive-in theater, lighting, directional (EA)
DTE	Drive-in theater, lighting, ground level (EA)
DTG	Drive-in theater, ramp, paved (EA car space)
DTJ	Drive-in theater, screen, concrete frame (SF screen area)
DTK	Drive-in theater, screen, steel frame (SF screen area)
DTL	Drive-in theater, screen, wood frame, braced (SF screen area)
DTM	Drive-in theater, screen, wood frame, guyed (SF screen area)
DTN	Drive-in theater, screen, wood frame, timbers (SF screen area)
DTT	Ticket Booth (EA)

MODEL 252 - X ILLUSTRATIONS



MODEL 252 - X ILLUSTRATIONS



MODEL 271 - X LODGE

These buildings are large, multi-purpose buildings designed for general use by fraternal organizations. They will generally have an auditorium, kitchen facilities, dining and game rooms, and office space. Some may also have a large meeting room with movable partitions.

- Lower quality improvements will tend to merge into the Clubhouse Model (272X).
- Average quality improvements will have some ornamentation and standard finishes.
- Good quality units will have good entrance and lobby, good kitchen.
- High quality improvements will have best quality finishes and large meeting rooms with movable partitions.

TYPE	EXTERIOR WALLS	INTERIOR FINISH	PLUMBING / ELECTRICAL	HEATING/COOLING
Excellent	Tilt-up panels, brick, steel columns, wide span, good front, some ornamentation	Acoustic tile, plaster or drywall, good offices, rubber or vinyl composition	Good lighting and outlets, good rest rooms	Zoned heating and cooling
Good	Brick or block, tilt-up, wood or steel columns and trusses, good sandwich panels, some ornamentation	Acoustic tile, plaster or drywall, good offices, rubber or vinyl composition	Good lighting and outlets, good rest rooms	Package heat / AC
Average	Brick, block, stucco, concrete panels, shallow display fronts	Acoustic tile, drywall, small office area, few partitions, vinyl composition	Adequate lighting and outlets, standard fixtures	Package heat / AC
Low Cost	Brick, concrete or face block, some all front trim only	Acoustic tile, drywall, few partitions, minimum finish and office	Minimum lighting, minimum plumbing	Gas space heat / evaporative cooling

MODEL 271 - X ILLUSTRATIONS



MODEL 271 - X ILLUSTRATIONS



MODEL 272 - X CLUBHOUSE

A general-purpose building used for recreation, meetings, classes, and entertainment. A clubhouse may have full or light kitchen facilities, a large multi-purpose room that may have a stage, and smaller meeting rooms or movable partitions.

This model is typically found in apartment complexes, mobile home or RV parks, community halls/centers, veteran organization buildings, and senior citizen facilities. If the building has basically an open interior with little or no interior partitioning, consider using model 282-x, Recreation Building.

- Lower quality improvements will be very plain with few partitions and will tend to merge into the Rec. Building Model.
- Average quality units will have some ornamentation and standard finishes.
- Higher quality units will tend to merge into the Lodge Model, 271-x.

TYPE	EXTERIOR WALLS	INTERIOR FINISH	PLUMBING / ELECTRICAL	HEATING/COOLING
Excellent	Face brick, glass panels, stone veneer, best sandwich panel, best quality	Plaster or drywall, terrazzo, tile pavers, hardwood, carpet, stage	Tiled rest rooms, full kitchen, special lighting	Zoned heating and cooling
Good	Concrete or metal panels, brick veneer, good stucco or siding, insulated sandwich panels, ornamentation	Drywall, hardwood, carpet, vinyl tile, small stage	Tiled rest rooms, good kitchen, adequate lighting/plumbing	Package heat / AC
Average	Brick, block, concrete panels, stucco or siding, insulated sandwich panels, pre-engineered frame, some trim	Drywall, acoustic tile, vinyl composition tile, concrete tile	Adequate lighting/plumbing, average rest rooms and kitchen	Package heat / AC
Low Cost	Block, tilt-up, stucco or siding, metal skin on pre-engineered frame, no trim	Painted walls, few partitions, concrete slab	Minimum lighting/plumbing	Gas space heat / evaporative cooling

MODEL 272 - X ILLUSTRATIONS



MODEL 272 - X ILLUSTRATIONS



MODEL 273 - X HEALTH CLUB

These are buildings designed as physical fitness centers, with varied exercise and conditioning areas. Generally the better quality clubs will have snack bars, massage and steam rooms, and sauna facilities in addition to locker rooms and showers.

- Lower quality improvements will be very plain, with minimal interior facilities.
- Average quality units will usually have standard interior finish with good exercise rooms and sauna or steam facilities.
- Good quality units will have well finished interiors, snack bar facilities, sauna and or steam rooms, and lounge areas.

TYPE	EXTERIOR WALLS	INTERIOR FINISH	PLUMBING / ELECTRICAL	HEATING/COOLING
Good	Stone trim, brick, metal or concrete panels and glass, brick veneer, best stucco or siding, some ornamentation	Plaster, carpet, tile, hardwood, good snack bar, lounge, and gym	Good lighting, lamps, steam, sauna, shower, locker and rest rooms	Warm and cool air (zoned)
Average	Brick, block, stucco, or siding, some brick or stone trim, insulated sandwich panels, steel frame	Plaster or drywall, carpet, vinyl composition, good exercise rooms	Adequate lighting, plumbing, sauna	Package Heat / AC
Low Cost	Concrete block, low-cost brick, tilt-up, stucco or siding, very plain, enameled metal siding	Painted block, drywall partitions, minimum facilities	Minimum shower and locker rooms, minimum lighting	Package Heat / AC

MODEL 273 - X ILLUSTRATIONS



MODEL 273 - X ILLUSTRATIONS



MODEL 274 - X HANDBALL-RACQUETBALL CLUB

These are structures that include the basic playing courts and auxiliary facilities commensurate with the quality of the structure. The better qualities will include spectator areas, lounges, snack bar and pro shop areas as well as full exercise, dressing, and shower areas.

- Average quality units will usually have standard interior finish with adequate sports lighting, showers.
- Good quality units will have best sports lighting, plumbing, many extra facilities and rooms.

TYPE	EXTERIOR WALLS	INTERIOR FINISH	PLUMBING / ELECTRICAL	HEATING/COOLING
Good	Brick or concrete, brick veneer , best siding, insulated metal sandwich panels , steel frame, good entrance	Plaster or drywall, carpeting, good lounge, spectator courts, pro shop, gym	Good sports lighting, rest rooms, sauna, shower and locker rooms	Package AC
Average	Brick, block, stucco, or siding, some brick or stone trim, insulated sandwich panels, steel frame	Plaster or drywall, carpet, vinyl composition, good exercise rooms	Adequate sports lighting, plumbing, showers	Package AC

MODEL 274 - X ILLUSTRATIONS



MODEL 274 - X ILLUSTRATIONS



MODEL 275 - X**CITY CLUB - "Y"**

These are private hotels with dining, gymnasium, and library facilities. Average quality structures are typical of large YMCA or YWCA buildings. Interiors are nicely finished with large amounts of plaster or drywall and good service areas.

- Average quality units will usually have standard interior finish with good lounge and public area, gym.
- Good quality units will have best detail, TV and phone jacks in rooms, excellent service and fixtures

TYPE	EXTERIOR WALLS	INTERIOR FINISH	PLUMBING / ELECTRICAL	HEATING/COOLING
Good	Brick or concrete, brick veneer, best metal and glass, face brick, stone trim, good entrance	Good plaster, paneling, carpet, fine detail	TV and phone jacks in rooms, excellent service and fixtures	Hot and chilled water (zoned)
Average	Brick, stone, metal or precast panels, little trim	Plaster or drywall, carpet, good lounge and public areas	Adequate steam room, gym	Warm and cool air (zoned)

MODEL 275 - X ILLUSTRATIONS



MODEL 275 - X ILLUSTRATIONS



MODEL 276 - X BOWLING ALLEY

This model includes plumbing and electrical for restaurants, billiard rooms, bars, and miscellaneous rooms, but does not include any of the fixtures such as alleys, ball returns, kitchen and bar equipment, or other trade fixtures.

- Average quality units will usually have standard interior finish with good lounge and public area, gym.
- Good quality units often have extra banquet facilities and good spectator seating.

TYPE	EXTERIOR WALLS	INTERIOR FINISH	PLUMBING / ELECTRICAL	HEATING/COOLING
Good	Brick or concrete, brick veneer , best metal and glass, face brick, stone trim, good entrance	Good plaster, paneling, carpet, fine detail	Extensive Lighting and outlets, good restrooms and kitchens	Hot and chilled water (zoned)
Average	Brick, stone, metal or precast panels, little trim	Plaster or drywall, carpet, good lounge and public areas	Good fluorescent lighting, kitchen and bar plumbing	Warm and cool air (zoned)

MODEL 276 - X ILLUSTRATIONS



MODEL 276 - X ILLUSTRATIONS



MODEL 277 - X COUNTRY CLUB

Country clubs are designed for entertainment and have few, if any, sleeping rooms. Group entertainment normally requires good kitchen facilities, minimum rest rooms with or without lockers and showers and large general use rooms. They typically have small offices and meeting rooms. Higher quality structures will have ballroom, bar, banquet and pro-shop facilities, as well as extensive locker and shower rooms.

- Lower quality improvements will generally be equivalent to an average clubhouse and will lack full shower and locker facilities. It may have a snack bar.
- Average quality units will usually have plain ornamentation, and standard interior finish with some partitions.
- Good quality units will have good ornamentation, with some fenestration and trim and well-finished interior with some partitions.
- High quality units will have good shower and locker facilities as well as lounge, dining, and banquet rooms.

TYPE	EXTERIOR WALLS	INTERIOR FINISH	PLUMBING / ELECTRICAL	HEATING/COOLING
Excellent	Ashlar and face brick, top architecture, much glass	Plaster, quality carpet, hardwood, ceramic tile, sheet vinyl	High-capacity electrical service, fine electric/plumbing fixtures	Zoned heating and cooling
Good	Stone or brick veneer, metal, concrete or glass panels, best stucco or siding, ornamentation	Plaster or drywall, carpeting, vinyl composition tile	Good lighting, bar, dining room, kitchen, good plumbing	Heat pump system
Average	Brick, block, stucco or siding, metal sandwich panel, some trim	Acoustic tile, drywall, small office area, few partitions, vinyl composition	Adequate lighting, showers, bar, kitchen, adequate rest rooms	Package heat / AC
Low Cost	Concrete block, stucco or wood siding, enameled metal siding, very plain	Unfinished block, drywall, few partitions, minimum facility	Minimum electrical/plumbing, minimum facilities	Gas space heat / evaporative cooling

MODEL 277 - X ILLUSTRATIONS



MODEL 277 - X ILLUSTRATIONS



MODEL 278 - X SKATING RINK

Skating rinks are typically lower quality auditoriums modified for that particular use. They are large, open structures that include areas for ice- or roller-skating, lobby, rest rooms and an equipment storage area. Lounge, snack bar, offices, locker or shower room facilities commensurate with the quality indicator are included in the interior component costs.

- Lower quality improvements will be identified by their lack of interior amenities.
- Average quality units will be primarily a shell with plumbing to accommodate a good size crowd, including snack and drink bars.
- Good quality units will have some extra amenities and will be of solid construction.

TYPE	EXTERIOR WALLS	INTERIOR FINISH	PLUMBING / ELECTRICAL	HEATING/COOLING
Good	Brick, concrete, best siding or stucco, insulated metal panels and roof, good entrance	Acoustic treatment, good viewers' seating, snack bar and locker room	Good lighting and rest rooms, some entertainment-type lighting	Package heat / AC
Average	Brick, block, stucco, siding, metal panels, some trim	Gypsum board, acoustic tile	Adequate lighting and plumbing	Package heat / AC
Low Cost	Block, tilt-up, siding, stucco, single wall, very plain	Little or none, no dressing rooms	Minimum lighting and plumbing	Gas space heat / evaporative cooling

MODEL 278 - X ILLUSTRATIONS



MODEL 278 - X ILLUSTRATIONS



MODEL 281 - X**MOBILE HOME PARK**

See [Volume 1, Appendix A, Mobile Home / Recreational Vehicle Parks](#), for a complete description and listing procedure.

MODEL 282 - X RECREATION BUILDING

Recreation buildings are typically found in mobile home parks, apartment, or condominium complexes. They have large open multipurpose rooms similar to a retail store.

If the improvement has small meeting rooms or offices and multiple rest rooms, use model 272-x (Clubhouse).

Do not add storefront.

TYPE	EXTERIOR WALLS	INTERIOR FINISH	PLUMBING / ELECTRICAL	HEATING/COOLING
Good	Brick, block, better stucco or siding, good sandwich panels and ornamentation	Acoustic tile, plaster or drywall, rubber or vinyl composition	Good lighting and outlets, good rest rooms	Package heat / AC
Average	Brick, block, stucco, concrete panels, stucco or wood siding, sandwich panels, some ornamentation	Acoustic tile, drywall, few partitions, vinyl composition	Adequate lighting and outlets, standard fixtures	Package heat / AC
Low Cost	Block, stucco, wood or metal siding, no ornamentation, very plain	Acoustic tile, drywall, minimum finish	Minimum lighting, minimum plumbing	Gas space heat / evaporative cooling

MODEL 282 - X ILLUSTRATIONS



MODEL 282 - X ILLUSTRATIONS



MODEL 283 - X**MOBILE HOME - RECREATIONAL VEHICLE PARK**

See [Volume 1, Appendix A, Mobile Home / Recreational Vehicle Parks](#), pp. 11 - 16 for a complete description and listing procedure.

MODEL 284 - X**RECREATIONAL VEHICLE PARK**

See [Volume 1, Appendix A, Mobile Home / Recreational Vehicle Parks](#), pp. 11 - 16 for a complete description and listing procedure.

MODEL 290 - X**PARKING LOT**

A commercial pay-to-park lot. Typically built in an urban, downtown area, this model is often a transient improvement on the land, built to generate income until a more appropriate and permanent improvement is built. Commercial parking lot components are listed as add items.

MODEL 291 - X PARKING GARAGE, ABOVE GRADE

Built above grade, these structures are designed for [live load](#) storage of autos. They commonly have either no exterior walls or partial exterior walls and are usually Class A or B buildings and, in some cases, Class S.

While the lower quality structures do not have office area, the better qualities have some small office and service areas. There is low level lighting and adequate plumbing for office rest rooms and service areas.

The quality of these structures can be influenced by their design characteristics. Ramp designs vary from separate and exclusive ramps, which separate the travel and the parking/unparking operations, to continuous sloping floor or adjacent ramp, which have both the travel and parking operations integrated within the same space. The determination of the type of ramp used is based on the site's shape, dimensions, and the parking demand characteristics.

TYPE	EXTERIOR WALLS	INTERIOR FINISH	PLUMBING / ELECTRICAL	HEATING/COOLING
Good	Partial walls, brick or concrete, ornamentation	Unfinished, except good office and service area	Reading level lighting, rest rooms and service plumbing	None
Average	Partial walls, brick, block, concrete, little trim, plain finish	Unfinished, small office and service area	Low-level lighting, drains, minimum rest room for office	None
Low Cost	Low parapets, precast frame and floors, exposed steel frame, minimum finish	Unfinished, minimum extras	Minimum lighting and plumbing	None

MODEL 291 - X ILLUSTRATIONS



MODEL 291 - X ILLUSTRATIONS



MODEL 292 - X PARKING GARAGE, BELOW GRADE

These structures, like aboveground parking garages, are made for automobile storage. They are structures built below grade and contain a number of levels. Structural steel or a reinforced concrete frame provides the majority of support for the parking structure. All floors are heavy concrete and the roof is load bearing. Ventilation systems are commonly found. They normally have small office and service facilities.

Ramp designs vary from separate and exclusive ramps, which separate the travel and the parking/unparking operations, to continuous sloping floor or adjacent ramp, which have both the travel and parking operations integrated within the same space. The determination of the type of ramp used is based on the site's shape, dimensions, and the parking demand characteristics.

TYPE	EXTERIOR WALLS	INTERIOR FINISH	PLUMBING / ELECTRICAL	HEATING/COOLING
Average	Unfinished concrete, waterproof walls and load-bearing roof	Unfinished, some office and service areas	Good lighting, rest rooms and service plumbing	Package heat / AC

MODEL 370 - X WAREHOUSE, TRANSIT

Transit Warehouses, sometimes called truck terminals, are designed for fast sorting and reshipment of freight. The entire building is usually raised to dock height and may be long and narrow. One or more exterior walls are comprised of overhead doors up to as much as ninety percent of total wall area. Exterior walls may be brick, block, concrete tilt-up, or metal. Electrical and plumbing are not excessive or ornate but sufficient to service small groups of personnel.

If possible, use the alternate interior method on this model. See [Appendix A, Warehouse Interior Finishes](#), for a complete listing procedure.

- Lower quality improvements will have unfinished, utility type interiors, minimum low-cost offices, and be built to minimum code.
- Average quality units will have small average quality finished offices and painted partitions.
- Good quality units will have above average plaster, drywall or masonry partitions, and good quality finished offices.

TYPE	EXTERIOR WALLS	INTERIOR FINISH	PLUMBING / ELECTRICAL	HEATING/COOLING
Good	Brick or block, best tilt-up, heavy steel frame and siding, good overhead doors	Good finished offices with driver's rest areas, dock-high floor	Good lighting and plumbing for personnel	Package heat / AC
Average	Block, wood frame, siding or stucco, steel frame and siding, average overhead doors	Some finished offices with driver's rest areas, dock-high floor	Sufficient lighting and plumbing for personnel	Space heaters, evaporative coolers

MODEL 370 - X ILLUSTRATIONS



MODEL 370 - X ILLUSTRATIONS



MODEL 371 - X WAREHOUSE, STORAGE

These warehouses are designed primarily for storage. These types of buildings are sometimes found in industrial park developments and may be leased as a warehouse or industrial building depending upon the needs of the owner. Wall height is typically 14 feet or more. Newer structures may have wall heights of 25 feet or more. Heating and ventilating systems are sufficient to protect goods from deterioration. Plumbing is usually minimal.

If possible, use the alternate interior method on this model. See [Appendix A, Warehouse Interior Finishes](#), for a complete listing procedure. Plate glass storefront is not included in the wall cost. All storefront must be added and this area must be deducted from the square footage of the wall component.

- Lower quality improvements are plain with no exterior ornamentation. Interiors typically are unfinished utility type with minimum low-cost offices and built to minimum code.
- Average quality unit will have small office fronts with some ornamentation. Interiors will have average quality finished offices and painted partitions.
- Good quality units will have ornamental facades with good quality painted offices and painted plaster, drywall or masonry partitions.

TYPE	EXTERIOR WALLS	INTERIOR FINISH	PLUMBING / ELECTRICAL	HEATING/COOLING
Excellent	Brick, concrete, heavy steel frame, insulated panels, good façade	Plaster or drywall, partitioned, finished ceilings in most areas	Good lighting and plumbing	Package heat / AC
Good	Ornamental concrete or brick, heavy wood or steel frame, mill type construction, wood, steel or stucco siding	Some good office, interior finish, and floor	Good lighting, adequate plumbing	Package heat / AC
Average	Brick, block, stucco on wood frame, wood truss, rigid steel frame, siding, very plain	Painted walls, a few drywall or masonry walls, small offices	Adequate lighting and plumbing	Gas space heat / evaporative cooling
Low Cost	Low-cost block or brick, tilt-up, stucco or wood siding, pre-engineered frame, metal siding	Unfinished, small office, shell type, minimum code	Minimum lighting and plumbing	Gas space heat / evaporative cooling

MODEL 371 - X ILLUSTRATIONS



MODEL 371 - X ILLUSTRATIONS



MODEL 372 - X WAREHOUSE, DISTRIBUTION

Distribution warehouses are designed with large areas to accommodate the breakdown of large lots of materials and goods into smaller lots. Exterior walls may be brick, block, concrete tilt-up, or metal with more fenestration than found in storage warehouses. More electrical and plumbing is required than is found in a storage warehouse to service a larger personnel load.

If possible, use the alternate interior method on this model. See [Appendix A, Warehouse Interior Finishes](#), for a complete listing procedure. Plate glass storefront is not included in the wall cost. All storefront must be added and this area must be deducted from the square footage of the wall component.

- Lower quality improvements will be plain with no ornamentation and lightweight construction. Interiors will be unfinished shell type with a minimum of office and other partitioned areas.
- Average quality units will have some ornamentation and interiors may have small to medium size average quality finished offices and painted partitions.
- Higher quality units will have ornamental concrete, brick or metal/glass paneled front elevations. Interiors may be plaster, drywall or masonry partitions, good quality medium to large finished offices with completely finished areas for drug, food, or bonded storage.

TYPE	EXTERIOR WALLS	INTERIOR FINISH	PLUMBING / ELECTRICAL	HEATING/COOLING
Excellent	Brick, metal/glass, heavy steel frame, ornamental facades, good fenestration	Completely finished, drug, food or bonded storage, large offices	High level lighting and good plumbing	Package heat / AC
Good	Ornamental concrete, brick, metal/glass panels, good steel or wood frame with stucco or siding, office front	Plaster or drywall with partitions, some good offices and interior finish, distribution areas	Good lighting and plumbing, rest rooms for personnel	Package heat / AC
Average	Brick, block, tilt-up, stucco or siding on wood or steel	Painted walls, small offices, distribution areas	Adequate lighting and plumbing	Gas space heat / evaporative cooling
Low Cost	Block, tilt-up, wood pole frame, pre-engineered frame, very plain, light construction	Unfinished, adequate offices, partitioned areas	Adequate lighting and plumbing	Gas space heat / evaporative cooling

MODEL 372 - X ILLUSTRATIONS





MODEL 373 - X MINI-STORAGE

Warehouse partitioned into small areas of various dimensions. Spaces are rented, generally for non-commercial storage. Partitions are of concrete block or frame. They are typically built on slab floor and have minimal electric. Some complexes have office and living quarters on the premises. Do **not** use the alternate interior method on this model. Costs for HA or HB include partitioning commensurate with the quality. Sectionalize or use appropriate interior overrides for office, rest rooms or living quarters.

TYPE	EXTERIOR WALLS	INTERIOR FINISH	PLUMBING / ELECTRICAL	HEATING/COOLING
Good	Brick, block, tilt up, wood or steel frame with wood , steel or stucco siding, many doors	Subdivided cubicles, good security partitions, office-apartment	Electrical outlets & lighting in each cubicle, minimum plumbing	None in storage areas
Average	Block, tilt up, wood or pre-engineered steel frame, wood or metal siding, light construction	Subdivided into cubicles, mixed sizes, unfinished slabs, small office	Adequate electrical service per space, minimum plumbing	None in storage areas
Low Cost	Low-cost block, tilt up, wood or light pre-engineered steel frame, wood or metal siding, low-cost door entry	Subdivided into large cubicles, light slab, no support facilities	Minimum electrical service	None in storage areas

MODEL 373 - X ILLUSTRATIONS



MODEL 373 - X ILLUSTRATIONS



MODEL 374 - X "T" HANGAR-AIRCRAFT

T-hangars are multiple hangars for small planes and may include partitioned areas for individual planes and small offices. The improvements will usually have structure and large clear spans. Interiors have concrete slab floors with very few extras. They usually have minimal electric, occasionally plumbing, and normally do not have heating or cooling.

Hangar doors **MDA, MDB, MDC** must be added by the square foot and this area must be deducted from the wall component.

- Lower quality improvements will have pole frame or pre-engineered steel exteriors with few extras and a light floor.
- Average quality units will have concrete block or enameled steel frame exteriors with partitioned aircraft storage and may have a small office.

TYPE	EXTERIOR WALLS	INTERIOR FINISH	PLUMBING / ELECTRICAL	HEATING/COOLING
Average	Concrete block, low-cost brick, tilt-up, good steel frame, enameled steel panels	Subdivided storage hangar, concrete floor, may have a small office	Adequate electrical and water service	None, except in office area
Low Cost	Pole frame and truss, pre-engineered steel, steel or metal siding	Subdivided storage hangar, few extras, light floor	Minimum electrical service	None

MODEL 374 - X ILLUSTRATIONS



MODEL 374 - X ILLUSTRATIONS



MODEL 375 - X INDUSTRIAL FLEX BUILDING

Industrial Flex Mall Buildings are the modern multi-tenant loft structures, typically of low-rise construction. The lower qualities are purely light industrial buildings having minimal subdivisions and finish per shop space user with overhead door entries. The better qualities have fully finished customer service areas with storefront entries. Display-office areas in the higher qualities have finished floors and ceilings with good rest room facilities.

They are intermediate buildings between industrial and office construction and may look like either.

Segregated system listings only: use the alternate interior method, if possible, on this model. See [Appendix A, Warehouse Interior Finishes](#), for a complete listing procedure. For square foot listings use the grading guide found in [Appendix A, Square Foot Training Manual](#).

Plate glass storefront is **not** included in the wall component. All storefront must be added and this area must be deducted from the square footage of the wall component.

- Lower quality improvements will be plain, no ornamentation and minimal, if any, office area.
- Average quality units will have some ornamentation and small office area.
- Good quality units will have good ornamentation, some storefront and a large partitioned office area.

TYPE	EXTERIOR WALLS	INTERIOR FINISH	PLUMBING / ELECTRICAL	HEATING/COOLING
Good	Brick or block, tilt-up, wood or steel columns and trusses, good sandwich panels , some ornamentation	Finished floors, ceilings and display rooms, partitioned offices, good floor and ceiling finishes	Good lighting and outlets, good rest rooms	Package heat / AC
Average	Brick, block, stucco, concrete panels, pre-engineered steel, shallow display fronts	Acoustic tile, drywall, small office area, few partitions, vinyl composition	Adequate lighting and outlets, standard fixtures	Package heat / AC
Low Cost	Low-cost block, stucco, wood or steel siding, very plain	Unfinished, slab, open shop areas only	Minimum lighting, minimum plumbing	Gas space heat / evaporative cooling

MODEL 375 - X ILLUSTRATIONS



MODEL 375 - X ILLUSTRATIONS



MODEL 376 - X AIRCRAFT STORAGE HANGAR

The buildings are designed for aircraft storage and light maintenance. The highest quality storage hangars are for line servicing of large commercial aircraft, while those of average quality are designed for light service and repair. These improvements will usually have structure and large clear spans. Storage hangars will have some office space, storage area, rest rooms, and plumbing facilities to support crews of maintenance personnel commensurate with the quantity and type of service performed. Above average quality may have a very nice waiting area and other areas for use by passengers and corporate executives.

Segregated system listings only: use the alternate interior method, if possible, on this model. See [Appendix A, Warehouse Interior Finishes](#), for a complete listing procedure.

Hangar doors **MDA, MDB**, and **MDC** must be added by the square foot and this area must be deducted from the wall component.

Plate glass storefront is **not** included in the wall component. All storefront must be added and this area must be deducted from the square footage of the wall component.

TYPE	EXTERIOR WALLS	INTERIOR FINISH	PLUMBING / ELECTRICAL	HEATING/COOLING
Excellent	Structural steel, concrete panels or heavy steel siding, major jet hangars	Offices, few partitions, heavy floor	Good lighting and plumbing	Zoned heating and cooling
Good	Structural steel frame, concrete panels, or steel siding, heavy structure	Offices, heavy floor	Good electrical and plumbing	Package heat / AC
Average	Steel or wood frame, block, tilt-up, stucco, light and medium aircraft hangars	Small office, concrete floor	Adequate electrical and plumbing	Package heat / AC
Low Cost	Block, tilt-up, wood or pre-engineered steel frame, wood, stucco or steel siding, light roof structure, light aircraft hangar	Concrete or asphalt floor, few extras	Minimum lighting and plumbing	Gas space heat / evaporative cooling

MODEL 376 - X ILLUSTRATIONS



MODEL 376 - X ILLUSTRATIONS



MODEL 376 - X ILLUSTRATIONS



MODEL 376 - X ILLUSTRATIONS



MODEL 377 - X WAREHOUSE, COLD STORAGE

These buildings are designed for storage of perishable goods. These structures are heavily insulated and usually have special cooling equipment. Typically these warehouses have plaster, drywall, or masonry interior partitions and may have some finished ceilings. Cold storage warehouses may be partitioned off in various areas according to degree of cooling. Some areas will be used to maintain above freezing temperatures for storage of produce, while other areas may be used to maintain temperatures below freezing for storage of frozen goods, and still other areas may maintain temperatures at below zero level for quick freeze areas. Each area will require a different amount of insulation including several layers of insulation under the concrete floor. Check blueprints where available. If possible, use the alternate interior method on this model. See Appendix A, [Warehouse-Cold Storage](#) and [Warehouse Interior Finishes](#), for complete listing procedures.

- Lower quality improvements will be plain with very little if any ornamentation.
- Average quality units will have small office fronts with some ornamentation.
- Good quality units will have good office fronts with ornamental materials at the front elevation.

TYPE	EXTERIOR WALLS	INTERIOR FINISH	PLUMBING / ELECTRICAL	HEATING/COOLING
Excellent	Best block, tilt-up, good steel frame, insulated panel walls and roof, good storefront and facade	Frozen foods, some good offices or production, sharp freeze, cooler areas	Good lighting and plumbing, outlets, and drains	Package heating and cooling in offices and break rooms
Good	Face brick, tilt up, good block, sandwich panels, good steel frame, heavily insulated	Chilled and freezer rooms, good offices and support areas	Good lighting and plumbing, outlets, and drains	Package heating and cooling in offices and break rooms
Average	Brick, block, concrete panels, steel or wood frame, stucco or wood siding, sandwich panel, insulated, good roof	Cooler and chilled rooms, some distribution offices and finish	Adequate lighting and plumbing	Package heating and cooling in offices and break rooms
Low Cost	Block, tilt-up, pole or metal frame, stucco, metal or wood siding, very plain, light construction, exposed ceiling insulation	Cooler storage, unfinished, few partitions, small office	Minimum lighting and plumbing	Gas space heat / evaporative cooling in offices and break rooms

MODEL 377 - X ILLUSTRATIONS



MODEL 377 - X ILLUSTRATIONS



MODEL 378 - X COVERED STORAGE, COMMERCIAL/INDUSTRIAL

These structures are designed as open (no walls or only partial walls), fully framed shelters for storage or for commercial / industrial applications. These structures provide cover for machinery, heavy equipment, material storage or fabrication.

Frame and roof structure will closely resemble those found in a typical warehouse, ranging from wood post and beam to a full structural steel frame with a wood or steel truss system.

- Lower quality improvements will have light pole frame or prefabricated steel structure with minimal quality roof cover.
- Average quality units will have heavier wood framing and trusses or arched prefabricated steel structure.
- Good quality units will have heavy timber trusses or full structural steel with wide clear spans.

MODEL 378 - X ILLUSTRATIONS

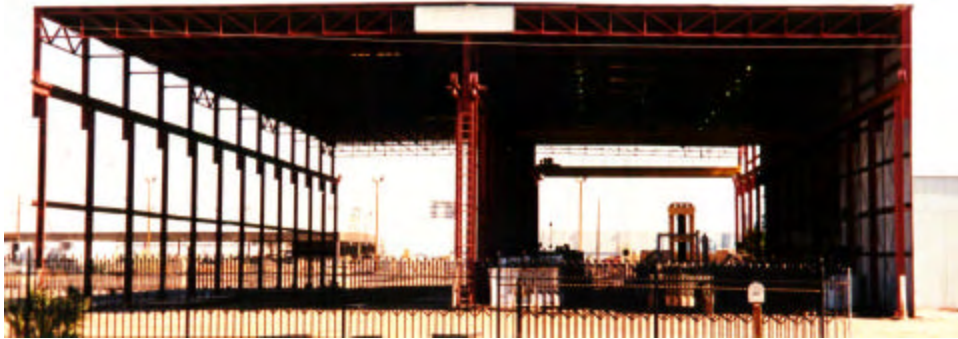

MODEL 378 - X ILLUSTRATIONS



MODEL 379 - X MEGA - WAREHOUSE

These large buildings, typically 200,000 to over a million square feet, are designed for major regional distribution and storage centers. They include an amount of office and personnel support space commensurate with the quality of the building (typically 1 to 5 percent). Support areas typically have plaster or drywall interior partitions and have finished ceilings. The better qualities have large cafeterias and kitchens. Heating and ventilating facilities are sufficient to protect goods from freezing and other spoilage. Material handling equipment is **not** included in the costs.

If possible, use the alternate interior method on this model. See [Appendix A, Warehouse Interior Finishes](#), for a complete listing procedure. Plate glass storefront is not included in the wall cost. All storefront must be added and this area must be deducted from the square footage of the wall component.

- Lower quality improvements will be plain with no ornamentation and lightweight construction. Interiors will be unfinished shell type with a minimum of office and other partitioned areas.
- Average quality units will have some ornamentation and interiors may have small to medium size average quality finished offices and painted partitions.
- Higher quality units will have ornamental concrete, brick or metal/glass paneled front elevations. Interiors may be plaster, drywall or masonry partitions, good quality medium to large finished offices with completely finished areas for drug, food, or bonded storage.

TYPE	EXTERIOR WALLS	INTERIOR FINISH	PLUMBING / ELECTRICAL	HEATING/COOLING
Good	Glulam, heavy steel frame, decorative block, good façade, elastomeric roof	Plaster or drywall, partitioned, good offices, cafeteria	Good lighting and plumbing, kitchen	Space heaters
Average	Wood or heavy steel frame, bar or web joints , good roof	Painted walls, finished offices and break room, good flat slab	Adequate lighting, good plumbing fixtures, food service	Space heaters
Low cost	Large tilt-up, rigid steel frame, built-up or metal roof, exposed insulation	Painted walls or unfinished, small offices, hardened slab	Adequate lighting and plumbing, some extras	Space heaters
Cheap	Tilt-up or steel frame, very large shell type	Unfinished, bulk storage, few offices	Minimum lighting and plumbing	Space heaters

MODEL 379 - X ILLUSTRATIONS



MODEL 379 - X ILLUSTRATIONS



MODEL 380 - X LUMBER STORAGE, HORIZONTAL

These structures are generally designed with an open front and three exterior walls. They are utilitarian framed buildings with wood, metal, or stucco exterior wall finishes. The cost of the storage racks is included in the interior construction component. If storage racks are not present, do not use component HA. The quality of the racks varies with the quality of the structure.

TYPE	EXTERIOR WALLS	INTERIOR FINISH	PLUMBING / ELECTRICAL	HEATING/COOLING
Good	Open front, some doors, good wood, stucco or steel siding on a wood or steel frame	Unfinished, light concrete or asphalt floor, good racks	Few lights on front	None
Average	Open front, good wood, stucco or steel siding on a wood or steel frame	Unfinished, asphalt floors, average racks	None	None
Low Cost	Open front, low-cost board or steel siding on a light steel or pole frame	Unfinished, asphalt or dirt floors, minimum racks	None	None

MODEL 380 - X ILLUSTRATIONS



MODEL 380 - X ILLUSTRATIONS



MODEL 381 - X EQUIPMENT MAINTENANCE- STORAGE

These structures are constructed for utilitarian purposes. Exterior walls are usually block or some type of metal, wood, or stucco over a wood or steel frame. Roof systems may be steel or wood with concrete or asphalt floors. The higher grades will generally have good electrical circuits and/or water service. Average grades may have little or no electric and/or water service.

If possible, use the alternate interior method on this model. See [Appendix A, Warehouse Interior Finishes](#), for a complete listing procedure.

TYPE	EXTERIOR WALLS	INTERIOR FINISH	PLUMBING / ELECTRICAL	HEATING/COOLING
Good	Concrete block, good wood, steel or pole frame, wood, stucco, or metal siding, overhead doors	Unfinished, concrete floor, shop area and cabinets	Good lighting and outlets, adequate plumbing	Gas space heater and/or evaporative cooler
Average	Concrete block, open wood or pre-engineered steel frame, wood, stucco or metal siding, windows	Unfinished, concrete or asphalt floor, some cabinets, work area	Adequate lighting and outlets, adequate plumbing	Gas space heater and/or evaporative cooler

MODEL 381 - X ILLUSTRATIONS



MODEL 381 - X ILLUSTRATIONS



MODEL 382 - X INDUSTRIAL / MANUFACTURING (Obsolete in the future)

This model will become obsolete in the future. List new improvements and change existing listings to one of the following models:

- 386-x Industrial / Light Manufacturing
- 387-x Industrial / Heavy Manufacturing

These structures are designed to shelter manufacturing processes. Exterior finishes are masonry or concrete, wood frame with siding or stucco or metal frame with siding. The interior, except for the office area, usually has no interior partitions and is a large opened area.

The office, which is typically 8 feet high, has drywall or plastered walls with ceiling and floor finishes. The shop area has exposed slab floors. Fluorescent light is commonly found through both the shop and office with the office area having the better quality fixtures.

The amount of window and door openings found in the exterior walls varies, the better qualities have more openings.

Selection of this model is mainly determined by the interior use of the structure. The building shell will be similar to a warehouse model. The main difference between the industrial building and a warehouse is in the function of the building. Typically, a manufacturing building will employ more personnel than one built for warehousing and will require more electric lighting, plumbing, and have less storage area.

Segregated system listings only: use the alternate interior method, if possible, on this model. See Appendix A, Warehouse Interior Finishes, for a complete listing procedure.

Plate glass storefront is **not** included in the wall component. All storefront must be added and this area must be deducted from the square footage of the wall component.

TYPE	EXTERIOR WALLS	INTERIOR FINISH	PLUMBING / ELECTRICAL	HEATING/COOLING
Good	Concrete bearing walls or frame, brick, tilt-up, good wood frame with stucco or wood siding, steel frame with metal siding or sandwich panels, good storefront entry and trim	Some good offices and interior finish	Good lighting, adequate plumbing	Package heating and cooling
Average	Brick, tilt-up, concrete or steel frame, concrete bearing walls, wood studs, stucco, wood rafters and sheathing, steel frame with metal siding or sandwich panel, some trim	Drywall, finished office area, exposed rafters or trusses, painted walls	Adequate lighting and plumbing	Package heating and cooling
Low Cost	Low-cost brick, block, tilt-up, wood studs or frame, cheap stucco or frame, light steel frame with steel or aluminum siding, few openings	Unfinished, few offices, low-cost slab, very plain and open, minimum code	Minimum lighting and plumbing	Gas space heat / evaporative cooling

MODEL 382 - X ILLUSTRATIONS



MODEL 382- X ILLUSTRATIONS



MODEL 384 - X INDUSTRIAL / MANUFACTURING - MEDIUM

Buildings designed to shelter medium manufacturing processes. Exterior finishes are masonry, concrete, or medium to heavy metal frame with metal siding. The interior, except for the office and employee break area, usually has no partitions and is a large opened area used for manufacturing, processing, or assembling of products. The interiors contain a larger and more elaborate office area than the typical industrial / manufacturing building. The best structures contain office areas with many partitions, best lighting, elevators, and fine detail.

These buildings will be similar in appearance to the 382-x model. The main difference will be the use of the building. Medium manufacturing will have heavier electrical service and plumbing than the 382 model. This building may be a single purpose building, designed and built to the exact specifications of the user.

Segregated system listings only: use the alternate interior method, if possible, on this model. See [Appendix A, Warehouse Interior Finishes](#), for a complete listing procedure.

TYPE	EXTERIOR WALLS	INTERIOR FINISH	PLUMBING / ELECTRICAL	HEATING/COOLING
Excellent	Steel or concrete frame, good curtain wall , masonry, metal or sandwich panel walls, ornamented entry and lobby	Many partitioned offices, interior office finish including acoustic ceilings, carpet and tile	Good fluorescent lighting, many outlets, good plumbing	Zoned heating and cooling
Good	Face brick, concrete curtain wall, metal panels, steel or concrete frame, masonry or stucco walls, good storefront and trim	Good office areas, plaster or gypsum partitions, some trim, heavy slab floors	Good lighting and plumbing, some extras	Package heat / AC
Average	Brick, formed concrete, metal panels, bearing wall, light steel or wood frame with wood siding, stucco or steel walls, good front	Some finished office area, good slab, some heavy assembly	Adequate lighting and plumbing	Package heat / AC
Low Cost	Precast concrete, masonry, wood frame with wood or stucco siding, pre-engineered steel with metal walls, small front	Small finished office area, some floor finish in open fabrication area	Minimum lighting and plumbing	Gas space heat / evaporative cooling

MODEL 384 - X ILLUSTRATIONS



MODEL 384 - X ILLUSTRATIONS



MODEL 385 - X INDUSTRIAL ENGINEERING

The exterior of an industrial engineering building is similar to that of an industrial manufacturing building, model 382-x. However, the interior has a larger amount of office area and finished space than the manufacturing model while containing some manufacturing, research and development, or assembly areas. The best structures approach good office buildings in cost with many partitions, best lighting, elevators or escalators, and fine detail.

Better quality exteriors have high cost features and ornamentation. Interiors at most qualities are plaster or drywall with fluorescent lighting and adequate plumbing for the personnel. The quality of the fixtures is commensurate with the quality of the structure.

Segregated system listings only: use the alternate interior method, if possible, on this model. See [Appendix A, Warehouse Interior Finishes](#), for a complete listing procedure.

If the design appears closer to office use than to industrial, office model 151-x should be used.

The Industrial Engineering model will typically be part of a complex that may include other industrial models. Sectionalize or create separate improvements, if appropriate.

TYPE	EXTERIOR WALLS	INTERIOR FINISH	PLUMBING / ELECTRICAL	HEATING/COOLING
Excellent	Good curtain walls , good brick, concrete or steel frame, ornamental entry and lobby	Plaster or gypsum board, carpet and resilient tile, mostly offices	Office type lighting, many outlets, good plumbing	Zoned heating and cooling
Good	Face brick or block, concrete or steel frame, stucco or brick veneer, good storefront and trim	Gypsum or plaster walls, acoustic ceilings, good office areas	Good fluorescent lighting, good plumbing	Package heat / AC
Average	Brick, concrete or metal panels, formed concrete or block walls, stucco or light steel panels, good front	Drywall walls and ceilings, resilient tile floors, half office buildout	Adequate lighting and plumbing	Package heat / AC
Low Cost	Precast concrete, block, tilt-up, wood frame or stucco, pre-engineered , small storefront entry	Low-cost finishes, plain offices, 20% to 30% buildout	Minimum lighting and plumbing	Package heat / AC

MODEL 385 - X ILLUSTRATIONS



MODEL 385 - X ILLUSTRATIONS



MODEL 386 - X INDUSTRIAL / LIGHT MANUFACTURING

Buildings designed to shelter manufacturing processes. The interior construction component HA includes an average amount of office and support space commensurate with the quality included, typically for light industrials, between 4 and 25 percent. This includes suitable locker, break and lunchroom facilities to accommodate the personnel load. Offices may be single story or stacked. Single story offices may have a soft wood flooring, storage mezzanine overhead as part of the office area costs. However, the alternate interior method is recommended for a more accurate cost.

The costs include all the power leads to the building and industrial sewer and drainage lines, but do **not** include the following: Power panel, power wiring or industrial piping to the fixture or equipment used in the manufacturing process, hoists or cranes.

Exterior finishes are masonry or concrete, typically tilt-up panels or metal siding. Frames are typically light open metal or glulam structures. The interiors, except for the office area, will usually have little or no interior finish. Fluorescent lighting is found throughout both the office and shop with the office area having better quality fixtures.

The office, which is typically 8 feet high, has drywall or plastered walls with ceiling and floor finishes. The shop area has exposed slab floors

The amount of window and door openings found in the exterior walls varies; the better qualities have more openings.

Selection of this model is mainly determined by the interior use of the structure. The building shell will be similar to a warehouse model. The main difference between the industrial building and a warehouse is in the function of the building. Typically, a manufacturing building will employ more personnel than one built for warehousing and will require more electric lighting, plumbing, and have less storage area.

Segregated system listings only: use the alternate interior method, if possible, on this model. See [Appendix A, Warehouse Interior Finishes](#), for a complete listing procedure.

Plate glass storefront is **not** included in the wall component. All storefront must be added and this area must be deducted from the square footage of the wall component.

TYPE	EXTERIOR WALLS	INTERIOR FINISH	PLUMBING / ELECTRICAL	HEATING/COOLING
Good	Bearing walls or frame, brick, concrete panels, stucco, wood or metal siding, sandwich panels, good glass storefront entry and trim	Some finished walls, some good offices and interiors	Good lighting, adequate plumbing	Space heaters, AC in office area, evaporative cooling
Average	Brick, formed concrete, tilt-up, light frame or bearing walls, stucco, wood or steel siding, some trim	Painted walls and exposed frame, finished office area, slab, some floor finish	Adequate lighting and plumbing	Space heaters, AC in office area, evaporative cooling
Low Cost	Low cost brick, block or tilt-up, cheap wood, stucco or metal siding, few openings	Unfinished, few offices, low-cost slab, very plain and open, minimum code	Minimum code, factory lighting	Space heaters, evaporative cooling

MODEL 386 - X ILLUSTRATIONS



MODEL 386 - X ILLUSTRATIONS



MODEL 387 - X INDUSTRIAL / HEAVY MANUFACTURING

Buildings designed for heavy specialized manufacturing processes and power or utility service plants. The interior construction component HA includes an average amount of office or support space commensurate with the quality included, typically for heavy industrials, between 4 and 12 percent. However, the alternate interior method is recommended for a more accurate cost.

Heavy industrials are characterized by their typically heavy frames, craneways, walls and floors. The structural support will greatly influence the cost and quality selection. Exterior finishes are thick masonry or concrete or heavy gauge metal siding. The interiors, except for the office, stores or shop area, usually have minimal interior partitions and are large opened areas. Lighting may consist of many heavy-duty or spark-proof fixtures.

The costs include all the power leads to the building and industrial sewer and drainage lines, but do **not** include the following: Power panel, power wiring or industrial piping to the fixture or equipment used in the manufacturing process or hoists / cranes.

Exterior finishes are masonry or concrete, typically tilt-up panels or metal siding. Frames are typically light open metal or glulam structures. The interiors, except for the office area, will usually have little or no interior finish. Fluorescent lighting is found throughout both the office and shop with the office area having better quality fixtures.

The office, which is typically 8 feet high, has drywall or plastered walls with ceiling and floor finishes. The shop area has exposed slab floors. The amount of window and door openings found in the exterior walls varies, the better qualities have more openings.

Selection of this model is mainly determined by the interior use of the structure. The building shell will be similar to a warehouse model. The main difference between the industrial building and a warehouse is in the function of the building. Typically, a manufacturing building will employ more personnel than one built for warehousing and will require more electric lighting, plumbing, and have less storage area.

Segregated system listings only: use the alternate interior method, if possible, on this model. See [Appendix A, Warehouse Interior Finishes](#), for a complete listing procedure.

Plate glass storefront is **not** included in the wall component. All storefront must be added and this area must be deducted from the square footage of the wall component.

TYPE	EXTERIOR WALLS	INTERIOR FINISH	PLUMBING / ELECTRICAL	HEATING/COOLING
Excellent	Heavy structural frame and masonry or concrete walls	Extra heavy floors, partitions and craneways, specialized plant	Excellent lighting and plumbing, spark-proof fixtures	Hot and chilled water (zoned)
Good	Good masonry or brick, or steel curtain walls with heavy steel, masonry, or mill type lumber frame, good load bearing masonry walls	Heavy floors, grating, good partitions and craneways	Good fluorescent lighting, good plumbing, some extras	Hot and chilled water (zoned)
Average	Brick, tilt-up, concrete or steel frame, concrete bearing walls, wood studs, stucco, heavy wood rafters and sheathing, steel frame with heavy metal siding or sandwich panel, some trim	Heavy floors, finished office area, some heavy assembly	Good fluorescent lighting, adequate plumbing, locker rooms	Warmed and cooled air (zoned)
Low Cost	Brick, block, formed concrete, stucco, wood or steel siding, steel or glulam framing	Painted walls and exposed frame, small finished office, open fabrication	Adequate lighting and plumbing	Gas space heat / evaporative cooling

MODEL 387 - X ILLUSTRATIONS



MODEL 391 - X QUONSET, COMMERCIAL / INDUSTRIAL

A prefabricated metal building for commercial or industrial applications having a semi-cylindrical roof of corrugated metal that curves down to the ground forming the exterior walls.

The following components should be used with this model:

YQA Quonset, Commercial (SF)

YQB Quonset, Industrial (SF)

The cost includes concrete footing, shell building with windows and doors and installation. Rank according to chart in Volume 2 component description.

The following components may be used to add interior construction, electric and/or plumbing:

HAY Interior Construction, Framed, Industrial

HAZ Interior Construction, Framed, Commercial

HBY Interior Construction, Masonry, Industrial

HBZ Interior Construction, Masonry, Commercial

IAY Plumbing, Industrial (SF - Floor Area)

IAZ Plumbing, Commercial (SF - Floor Area)

LAY Electric, Finished, Industrial (SF)

LAZ Electric, Finished, Commercial (SF)

LBY Electric, Unfinished, Industrial (SF)

LBZ Electric, Unfinished, Commercial (SF)

MODEL 391 - X ILLUSTRATIONS



MODEL 391 - X ILLUSTRATIONS



MODEL 900 - X POST OFFICE

Post office buildings are built to receive, sort, and distribute letters and parcels for the U. S. Postal Service. The exteriors vary, but generally include some ornamentation even at the low quality levels. Interiors are plaster or drywall. The most common floor finishes are vinyl, terrazzo, or ceramic tile.

A post office commonly has sorting area, lobby, office, employee restrooms, loading area with dock, and mechanical rooms. The area associated with each of these segments varies due to the overall size of the building and the community served.

- Lower quality post offices will typically be the smaller neighborhood branch post office. They have limited facilities and are built to standard specifications by the Postal Service.
- Average quality units will be the larger, individually designed substation or larger postal facility. They present a standard attractive appearance conforming to local architecture and have adequate facilities.
- Good quality units will have good workmanship, materials, and architectural design with some decorative features and good fenestration and interiors.

TYPE	EXTERIOR WALLS	INTERIOR FINISH	PLUMBING / ELECTRICAL	HEATING/COOLING
Excellent	Tilt-up panels, brick, steel columns, wide span, good front, some ornamentation	Acoustic tile, plaster or drywall, good offices, rubber or vinyl composition	Good lighting and outlets, good rest rooms	Zoned heating and cooling
Good	Brick or block, tilt-up, wood or steel columns and trusses, good sandwich panels, some ornamentation	Acoustic tile, plaster or drywall, good offices, rubber or vinyl composition	Good lighting and outlets, good rest rooms	Package heat / AC
Average	Brick, block, stucco, concrete panels, shallow display fronts	Acoustic tile, drywall, small office area, few partitions, vinyl composition	Adequate lighting and outlets, standard fixtures	Package heat / AC
Low Cost	Brick, concrete or face block, some all front trim only	Acoustic tile, drywall, few partitions, minimum finish and office	Minimum lighting, minimum plumbing	Gas space heat / evaporative cooling

MODEL 900 - X ILLUSTRATIONS



MODEL 900 - X ILLUSTRATIONS



MODEL 901 - X COURTHOUSE / CITY HALL

This model includes courthouses and city halls but does not include typical governmental office or service buildings. They may be massive masonry buildings or ones that utilize modern exterior curtain walls. The better quality improvements will have well-finished chambers and hearing rooms, as well as executive offices, while average quality courthouses and city halls will have only a few decorative features.

The buildings are built using all classes of construction. Exteriors vary with the building class. Typical finishes will include marble, granite, concrete, metal and glass panels, concrete block and various types of masonry veneer.

Interiors commonly utilize high-use floor coverings including terrazzo, marble, carpet, ceramic tile, and in some cases resilient vinyl tile. Most, except for the lowest quality improvements, have combined heating and cooling systems.

- Lower quality improvements will be found in many small towns and unincorporated areas with very plain utilitarian finishes.
- Average quality units will have typical fenestration, ornamentation, and interiors.
- Higher quality units are usually found in large cities. They may represent all jurisdictions: city, county, state, or federal and approach the excellent range with fine interiors and detail work.

TYPE	EXTERIOR WALLS	INTERIOR FINISH	PLUMBING / ELECTRICAL	HEATING/COOLING
Excellent	Walls are very ornamental, marble, granite, stone, best quality metal and glass	Plaster, marble trim, ornate detail, terrazzo , carpet, paneling	Best lighting and outlets, tiled rest rooms, many fixtures	Hot and chilled water (zoned)
Good	Good metal and glass, best ornamental masonry, face brick or stone vener , good entrance, fine fenestration	Plaster and drywall, some paneled offices, terrazzo , vinyl tile, good detail	Good lighting and outlets, good tiled rest rooms	Warmed and cooled air (zoned)
Average	Brick, concrete panels, metal and glass, ornamental stucco or brick veneer, little ornamentation	Plaster or drywall, some paneled offices, some carpet, vinyl composition tile	Adequate lighting and outlets, adequate plumbing	Warmed and cooled air (zoned)
Low Cost	Precast concrete, brick, block, tilt-up, stucco or siding, sandwich panel , very plain	Drywall, acoustic tile, asphalt tile	Adequate lighting and plumbing	Package heating and cooling

MODEL 901 - X ILLUSTRATIONS



MODEL 901 - X ILLUSTRATIONS



MODEL 902 - X LIBRARY

These are structures used to provide books and services to meet the reading and research needs of a community. Variations can be found in the design due primarily to the amount of service programs and the amount of people serviced by the library.

Typically there are control areas, staff work areas, reading areas, collection areas, and rest rooms. The better quality libraries may have study cubicles, conference/meeting rooms, audio-visual facilities, and various processing, cataloging, and exhibiting areas.

Exteriors in the better qualities have special features and designs that may include marble or other stonework, special veneers, ornate entries, and metal and glass panels. Lower grades are plain with little, if any, ornamentation.

Interiors of better quality libraries are very similar to those found in large cities. Plaster or drywall finish with wallpaper or paneling, carpet, vinyl or terrazzo, and high-cost lighting is frequently found.

- Lower quality improvements will typically be very plain small branch libraries.
- Average quality units will be small town or branch libraries.
- Higher quality units will be main libraries of major metropolitan areas.

TYPE	EXTERIOR WALLS	INTERIOR FINISH	PLUMBING / ELECTRICAL	HEATING/COOLING
Excellent	Special architecture, metal and glass, best masonry	Plaster, carpeting, vinyl, typical university or large city	High-level lighting, audio-visual wiring, good plumbing	Zoned heating and cooling
Good	Face brick or block, stone, metal or glass, good entrance, ornamentation and fenestration	Plaster or drywall, terrazzo or vinyl, typical college or small city	High level lighting, good plumbing	Zoned heating and cooling
Average	Good masonry or masonry veneer, good stucco or siding, metal panels	Drywall, acoustic and vinyl tile, typical neighborhood branch	Good lighting, adequate plumbing	Package heat / AC
Low Cost	Block, brick, tilt-up, stucco or siding, pole frame, metal siding, little trim, residential type windows	Painted masonry, drywall, asphalt tile, few extras	Adequate lighting and plumbing	Package heat / AC

MODEL 902 - X ILLUSTRATIONS



MODEL 902 - X ILLUSTRATIONS



MODEL 903 - X CHURCH

Churches are buildings designed to be used by religious denominations or groups for religious gatherings. They are characterized by a large capacity for seating, wide clear spans, high ceilings, and relatively few partitions. Ancillary offices and other partitioned rooms typical to this model are included in the interior construction component.

- Lower quality improvements will be of simple construction and design.
- Average quality units will be typical neighborhood or small town churches with simple designs and moderate fenestration and stained glass.
- Good quality units will have more costly walls, trim, and stained glass.
- High quality units will typically be a masonry structure with elaborate design and a fine quality interior finish.

TYPE	EXTERIOR WALLS	INTERIOR FINISH	PLUMBING / ELECTRICAL	HEATING/COOLING
Excellent	Fine masonry, face brick or stone veneer, fine windows, special architecture and trim	Finest plaster and wood detail, carpet, marble, vinyl tile	Special lighting and sound systems, good plumbing	Zoned heating and cooling
Good	Stone, face brick or block, stone veneer, best stucco or siding, good sandwich panel, good stained glass and trim	Good plaster or wood, marble, carpet and tile	Good lighting and sound system, good plumbing	Zoned heating and cooling
Average	Concrete, metal and glass, brick or block, stucco or siding, insulated sandwich panel, leaded stained glass windows, some trim	Drywall and veneers, some ornamentation, vinyl composition tile, acoustic tile, little trim	Adequate lighting, sound system, and plumbing	Package heat / AC
Low Cost	Low-cost block, brick, siding or stucco, composition roof, very plain, finished interior	Drywall and plywood, asphalt tile, very plain, few extras	Minimum lighting and plumbing	Gas space heat / evaporative cooling

MODEL 903 - X ILLUSTRATIONS



MODEL 903 - X ILLUSTRATIONS



MODEL 903 - X ILLUSTRATIONS



MODEL 903 - X ILLUSTRATIONS



MODEL 904 - X FIRE STATION

This improvement is used by a full-time fire department. The buildings are designed for engine storage, dormitory, and light kitchen facilities. The better quality fire stations are able to serve as a command post for major fire control.

The number of kitchens, showers, and offices found in the building is commensurate with the size of the fire station and the number of personnel in the fire unit.

- Lower quality improvements will be often found in outlying areas or as a satellite station. It is of minimum construction with little interior finish. It may have minimum dormitory and eating facilities.
- Average quality units will be similar to company-size fire units in city areas and are also equipped for 24-hour watch with cooking facilities and dormitory area.
- Good quality units will often be equipped to fight major fires with communications to serve as a command post at a battalion level.

TYPE	EXTERIOR WALLS	INTERIOR FINISH	PLUMBING / ELECTRICAL	HEATING/COOLING
Excellent	Face brick, stone or stone veneer, architectural concrete, good entrance	Fully equipped, kitchen, tile showers, offices, major command post	Good lighting and outlets, good plumbing	Zoned heating and cooling
Good	Face brick, stone metal and glass, best stucco or siding, good sandwich panels, good entrance and trim	Kitchen, showers, offices, drywall or plaster, vinyl tile	Good lighting and outlets, good plumbing	Package heat / AC
Average	Precast concrete, brick, block, stucco or siding, sandwich panels, some ornamentation	Drywall and acoustic tile, some living and office area	Adequate lighting and plumbing	Package heat / AC
Low Cost	Brick, block, tilt-up, stucco or siding, metal exterior, very plain	Minimum watch type, drywall, small finished areas	Minimum lighting and plumbing	Wall furnace / evaporative cooling

MODEL 904 - X ILLUSTRATIONS



MODEL 904 - X ILLUSTRATIONS



MODEL 905 - X PRISON / CORRECTIONAL FACILITY

Prisons or Correctional Facilities are buildings used for the detention of people either awaiting trial or for convicted offenders serving sentences for law violations. Divided into cells, most jails are built of either steel frame, reinforced concrete, or masonry.

Floor coverings typically include asphalt or vinyl tile and lower quality jails use only exposed concrete slab floors. Interior finishes are plain, using exposed masonry or painted finishes. Lighting and plumbing are adequate to serve both the detained and supervisory personnel.

Cell hardware (metal bars, doors, locking devices and ancillary items associated with cell blocks) are **not** included in the segregated cost system but may be listed using component **UX** (jail equipment). Cell hardware is included in the square foot component. In either case, the costs for kitchen, laundry or recreational equipment are **not** included.

TYPE	EXTERIOR WALLS	INTERIOR FINISH	PLUMBING / ELECTRICAL	HEATING/COOLING
Excellent	Best brick, stone, architectural concrete, good ornamentation	Plaster or drywall, ceramic tile, acoustic tile and vinyl	Best lighting and security, good plumbing	Zoned hot and chilled water
Good	Concrete, limestone, granite, brick or brick veneer with best stucco or siding, good trim, some ornamentation	Plaster and acoustic tile, vinyl and ceramic floors	Good lighting, plumbing and security	Zoned warm and cooled air
Average	Concrete, limestone, granite, brick, block, stucco siding or sandwich panel with metal liner	Painted walls, few partitions, slabs, some acoustic and vinyl composition	Adequate lighting and plumbing	Package heat / AC
Low Cost	Block, tilt-up, very plain	Unfinished walls and floors, low-cost ceilings	Minimum jail plumbing and lighting	Gas space heat / evaporative cooling

MODEL 905 - X ILLUSTRATIONS



MODEL 905 - X ILLUSTRATIONS



MODEL 906 - X ELEMENTARY SCHOOL (ALL BUILDINGS)

These models include the entire school facility. There is a mixture of classrooms, multipurpose buildings, administrative offices, etc. The school may consist of one building or several separate buildings.

The exterior appearance and interior finish of schools more often conform in quality than in any other type of property. However, this is not a specific rule, especially in older buildings where the electric and mechanical items are generally inferior to the modern schools of today.

TYPE	EXTERIOR WALLS	INTERIOR FINISH	PLUMBING / ELECTRICAL	HEATING/COOLING
Excellent	Stone, best brick, steel frame, metal and glass, highly ornamental	Plaster, enamel, glazed finishes, carpet and vinyl	Best classroom lighting and cabling systems, best plumbing	Zoned hot and chilled water
Good	Face brick, stone, concrete or metal panels, best stucco, pre-engineered , good sandwich panels	Plaster or drywall, acoustic tile, carpet, vinyl composition	Good fluorescent fixtures, good plumbing	Zoned warm and cooled air
Average	Brick, block, concrete, good stucco or siding, metal sandwich panels, some ornamentation and trim	Plaster or drywall, acoustic tile, vinyl composition or hardwood	Adequate lighting and plumbing	Package heat / AC
Low Cost	Brick, block, tilt-up, wood frame, stucco or siding, pole or pre-engineered frame, metal panels, little trim	Painted drywall walls, acoustic tile or drywall ceilings, asphalt tile	Minimum school lighting and plumbing	Forced air heat / evaporative cooling

MODEL 906 - X ILLUSTRATIONS



MODEL 906 - X ILLUSTRATIONS

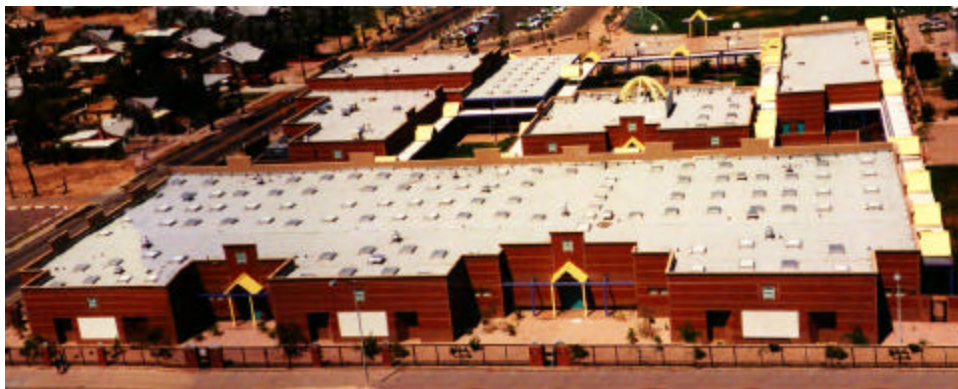

MODEL 907 - X SECONDARY SCHOOL (ALL BUILDINGS)

These models include the entire school facility. There is a mixture of classrooms, multipurpose buildings, administrative offices, etc. The school may consist of one building or several separate buildings.

The exterior appearance and interior finish of schools more often conform in quality than in any other type of property. However, this is not a specific rule, especially in older buildings where the electric and mechanical items are generally inferior to the modern schools of today.

TYPE	EXTERIOR WALLS	INTERIOR FINISH	PLUMBING / ELECTRICAL	HEATING/COOLING
Excellent	Stone, best brick, steel frame, metal and glass, highly ornamental	Plaster, enamel, glazed finishes, carpet and vinyl	Best classroom lighting and cabling systems, best plumbing	Zoned hot and chilled water
Good	Face brick, stone, concrete or metal panels, best stucco, pre-engineered , good sandwich panels	Plaster or drywall, acoustic tile, carpet, vinyl composition	Good fluorescent fixtures, good plumbing	Zoned warm and cooled air
Average	Brick, block, concrete, good stucco or siding, metal sandwich panels, some ornamentation and trim	Plaster or drywall, acoustic tile, vinyl composition or hardwood	Adequate lighting and plumbing	Package heat / AC
Low Cost	Brick, block, tilt-up, wood frame, stucco or siding, pole or pre-engineered frame, metal panels, little trim	Painted drywall walls, acoustic tile or drywall ceilings, asphalt tile	Minimum school lighting and plumbing	Forced air heat / evaporative cooling

MODEL 907 - X ILLUSTRATIONS



MODEL 907 - X ILLUSTRATIONS



MODEL 400 - X**LABOR DORMITORY - BUNK HOUSE**

These buildings provide living quarters for transient laborers or permanent ranch hands. The better qualities, either masonry or wood frame construction, are designed with good [fenestration](#), insulated walls, individual rooms, good lighting, and common shower facilities. The lower qualities include less fenestration, large common areas with minimum plumbing and lighting.

TYPE	EXTERIOR WALLS	INTERIOR FINISH	PLUMBING / ELECTRICAL	HEATING/COOLING
Average	Block, wood frame or stucco	Drywall, interior partitioning	Adequate lighting and outlets, standard fixtures	Space heat / evaporative cooling
Low Cost	Block or wood frame	Drywall, minimum interior, common rooms	Minimum lighting, minimum plumbing	Freestanding stove

MODEL 400 - X ILLUSTRATIONS



MODEL 400 - X ILLUSTRATIONS



MODEL 401 - X DAIRY

These buildings are designed for the milking of cows and first stage milk processing. Most, except for the lower quality units, have the capability for short-term storage. The structures are built to comply with state health and sanitation codes.

Usually built of masonry or wood frame construction, they have contoured concrete floors with epoxy or tile finishes.

- Higher quality units will have high level lighting, cow washes, rest rooms, showers, pipe stanchions, and milk piping. The units are generally not heated.

TYPE	EXTERIOR WALLS	INTERIOR FINISH	PLUMBING / ELECTRICAL	HEATING/COOLING
Excellent	Brick, or block w/stucco, best steel or wood siding, fully insulated, heavy roof structure	Ceramic & epoxy finishes, contoured concrete floor, plaster ceiling	High-level lighting, hot water, cow wash, rest rooms and shower	None
Good	Brick, concrete block, good wood or steel siding, insulated, good frame	Plaster or gypsum board, cooler and storage, contoured concrete floors	Good lighting and plumbing, pipe stanchions, milk piping	None
Average	Brick, concrete block, wood or stucco siding, light wood trusses, windows or good shutters	Gypsum board or plaster, wainscot in cooler and washroom	Adequate lighting and plumbing, pipe stanchions	None
Low Cost	Concrete block, steel or wood siding or plywood, light wood frame, shutters	Painted walls, concrete milking floor, milking parlor only, no storage	Minimum electric and plumbing, wood stanchions	None

MODEL 401 - X ILLUSTRATIONS



MODEL 401 - X ILLUSTRATIONS



MODEL 405 - X POULTRY HOUSE

These are complete environmental buildings designed for the care and housing of fowl. Quality is influenced by roof systems, the amount and character of the windows, floor systems (e.g., slab with drain, slab without drain, wood or dirt), the amount of interior finish and the lighting and plumbing systems.

TYPE	EXTERIOR WALLS	INTERIOR FINISH	PLUMBING / ELECTRICAL	HEATING/COOLING
Good	Brick, block, best stucco or steel panels, heavy roof, well insulated, good fenestration	Finished interior walls, good concrete walls with drains	Wiring in conduit, high-level lighting, water service	None
Average	Brick, block, stucco or wood frame, insulated, adequate fenestration	Painted, concrete floors, some partitions	Good lighting and outlets, water service	None
Low Cost	Concrete block, wood or steel siding, some insulation	Unfinished, low-cost concrete or wood floors	Adequate electrical service, water service	None
Cheap	Metal on poles, light frame, sidewall vents	Unfinished, cheap floor	Minimum service	None

MODEL 405 - X ILLUSTRATIONS



MODEL 405 - X ILLUSTRATIONS



MODEL 407 - X GREENHOUSE, COMMERCIAL

These are commercial greenhouses with straight, bow, or modified bow frame. The walls and roof are composed of glass, structural polycarbonate, fiberglass, single or double layer inflated plastic film.

The following special purpose components should be used to list the shell greenhouse:

Special Purpose Buildings (20) (Composite Component Codes)

YGA	GREENHOUSE, STRAIGHT WALL, CURTAIN (SF)
YGB	GREENHOUSE, STRAIGHT WALL, FIBERGLASS (SF)
YGC	GREENHOUSE, STRAIGHT WALL, GLASS (SF)
YGD	GREENHOUSE, STRAIGHT WALL, PLASTIC, DOUBLE (SF)
YGE	GREENHOUSE, STRAIGHT WALL, PLASTIC, SINGLE (SF)
YGF	GREENHOUSE, STRAIGHT WALL, STRUCTURAL POLYCARBONATE (SF)
YGJ	GREENHOUSE, BOW, FIBERGLASS (SF)
YGK	GREENHOUSE, BOW, PLASTIC, DOUBLE (SF)
YGL	GREENHOUSE, BOW, PLASTIC, SINGLE (SF)
YGM	GREENHOUSE, BOW, STRUCTURAL POLYCARBONATE (SF)
YGR	GREENHOUSE, MODIFIED BOW, FIBERGLASS (SF)
YGS	GREENHOUSE, MODIFIED BOW, PLASTIC, DOUBLE (SF)
YGT	GREENHOUSE, MODIFIED BOW, PLASTIC, SINGLE (SF)
YGU	GREENHOUSE, MODIFIED BOW, STRUCTURAL POLYCARBONATE (SF)

The cost includes foundations, framing, wall and roof panels, lighting service, and water service up to the automatic watering systems. Costs do **not** include floor, stem walls, heating and cooling, plumbing, or automatic watering systems.

- Lower quality units will have a wood or pipe frame.
- Average quality units will have an average steel frame.
- Good quality units will have a good aluminum or galvanized steel frame.
- High quality units will have a high quality aluminum or galvanized steel frame.

Use the following components to list greenhouse adds. They are restricted to model 407-x.

Heating, Cooling & Ventilation (17)

KGD	EXHAUST FAN (EA)
KGE	GAS FURNACE (SF)
KGF	HOT WATER HEATING (SF)
KGG	HUMIDIFIER (EA)
KGJ	SPACE HEAT (SF)
	USE KGA FOR DUCT DISTRIBUTION
KGK	HUMIDITY PAD, WATER DRIP (SF PAD AREA)
KGL	STEAM HEAT (SF)
KGM	VENT, AUTOMATIC (EA)

>>>> continued on next page >>>>

Plumbing (15)

- IGA** PLASTIC WATER SYSTEM (SF AREA COVERED)
- IGB** AUTOMATIC WATER SYSTEM CONTROLS (EA)

Yard Improvements (36)

- EGA** ASPHALT WALK (SF WALK AREA)
- EGB** GRAVEL WALK (SF WALK AREA)
- EGC** CONCRETE WALK (SF WALK AREA)

MODEL 407 - X ILLUSTRATIONS



MODEL 407 - X ILLUSTRATIONS



MODEL 407 - X ILLUSTRATIONS



www.azgs.az.gov

MODEL 407 - X ILLUSTRATIONS



MODEL 408 - X**HOG FINISHING / FARROWING BARN**

These environmental barns provide for farrowing, raising, and fattening of swine. Walls are typically insulated using block, plywood, wood, or metal siding as the exterior cover. There usually is some electrical and water to the pens. Most have some type of flushing system. Higher quality types are suitable for Environmental Control Confinement Housing.

TYPE	EXTERIOR WALLS	INTERIOR FINISH	PLUMBING / ELECTRICAL	HEATING/COOLING
Good	Brick, block, wood, stucco or metal siding, good ventilation and fenestration, fully insulated	Insulated, slab floor, subdivided	Good lighting and water service	None
Average	Block, stucco, wood or steel siding and frame, insulated	Insulated ceiling, plywood interior, slab floor, some subdivision	Adequate lighting, water service	None
Low Cost	Block, vertical boards or plywood, metal siding and frame, some insulation	Unfinished, partial floor, some division of space	Minimum lighting and water service	None
Cheap	Cheap block, plywood or low cost boards, metal siding and frame	Unfinished, dirt floor	Minimum services	None

MODEL 408 - X ILLUSTRATIONS



MODEL 408 - X ILLUSTRATIONS



MODEL 412 - X COTTON GIN

These buildings are designed to enclose the processing equipment used for the ginning and baling of cotton. Cotton Gins are typically pre-engineered metal buildings with steel structure and metal wall and roof cover.

- Lower quality improvements will be semi-automated, older facilities.
- Average quality units will be a modern, fully automated facility.

TYPE	EXTERIOR WALLS	INTERIOR FINISH	PLUMBING / ELECTRICAL	HEATING/COOLING
Average	Steel frame, good steel or aluminum siding, some trim	Finished office and control areas, fully automated, concrete slab, pit, and tunnels	Adequate lighting and plumbing	None
Low Cost	Light metal frame and siding, few openings	Minimum partitions, semi-automated, concrete slab and tunnels	Minimum lighting and plumbing	None

MODEL 412 - X ILLUSTRATIONS



MODEL 412 - X ILLUSTRATIONS



MODEL 421 - 3	VINEYARDS
MODEL 431 - 3	CITRUS TREES
MODEL 441 - 3	OTHER TREE CROPS
MODEL 442 - 3	NUT TREES
MODEL 443 - 3	PECAN TREES
MODEL 444 - 3	JOJOBA PLANTS
MODEL 445 - 3	DATE / OLIVE TREES
MODEL 446 - 3	CHRISTMAS TREES



Use these models to value all vineyards and tree crops. See [Form #82367](#) (Permanent Crop Data Collection Form) and component descriptions for a complete list of available components. See [Appendix A](#) for a complete listing procedure.

MODEL 450 - X PRODUCE PACKING BARN

These structures provide for the sorting, packing, and short-term storage of fresh produce. They typically have built-in refrigerated coolers for the fresh produce and a concrete slab floor. There may also be a small finished office area. Lighting is high level and some water service is usually included.

TYPE	EXTERIOR WALLS	INTERIOR FINISH	PLUMBING / ELECTRICAL	HEATING/COOLING
Average	Block or tilt-up, plywood or steel siding and frame, metal or composition roof	Cooler, concrete slab, small finished office	Good lighting, water service	None

MODEL 450 - X ILLUSTRATIONS



MODEL 450 - X ILLUSTRATIONS



MODEL 451 - X BARN

This structure is built for storage of agricultural products, livestock and / or equipment. Common roof types are [gambrel](#) and [monitor](#), thus allowing for loft area.

- Lower quality units will have dirt floors and simple gable or shed roofs.
- Higher quality units will have lighting, plumbing, interior partitions, large openings, and a plank or concrete floor system.

TYPE	EXTERIOR WALLS	INTERIOR FINISH	PLUMBING / ELECTRICAL	HEATING/COOLING
Excellent	Brick or block, best siding or brick veneer , good fenestration , heavy frame and roof structure, gambrel roof	T & G wainscot , concrete floor, good stalls and dairy facilities	Good wiring, water and power outlets, rest room	None
Good	Block, structural tile, lap siding, steel panels on steel frame, some windows, arch or gambrel roof	Plank or concrete floor, stalls, feed room, good stalls and dairy facilities	Adequate lighting and power outlets, water service and drains	None
Average	Brick, block, board and batten or low-cost woods siding, pole or wood frame, metal siding and frame, few windows	Some floor, few partitions and stalls, feed room	Minimum electrical and water outlets	None
Low Cost	Block, board or metal siding, light structure	Unfinished, dirt floor, few cheap stalls	None	None

MODEL 451 - X ILLUSTRATIONS



MODEL 451 - X ILLUSTRATIONS



MODEL 452 - X**AGRICULTURAL UTILITY BUILDING**

The agricultural utility building is a multipurpose structure used for general material, equipment or commodity storage, garage, etc. They are generally lighter in structure than typical commercial warehouses. Commercial structures tend to be more structurally sound, i.e., heavier gauge materials or more interior finishes, flooring, etc., than their farm counterpart. Interior modifications can turn agricultural utility buildings into one of several uses. The better farm qualities may be lined and used specifically for feed, seed, or grain storage.

TYPE	EXTERIOR WALLS	INTERIOR FINISH	PLUMBING / ELECTRICAL	HEATING/COOLING
Good	Brick, concrete block, wood or metal siding w/ heavy frame, bulkheads, wood or metal rafters	Finished walls, good slab or plank floor	Adequate wiring and outlets, water service	None
Average	Block, wood or metal siding, windows, walk, door	Unfinished walls, cheap slab or asphalt	Adequate wiring and outlets, water service	None
Low Cost	Light wood or steel frame, board or metal siding, sliding door entry only	Unfinished, dirt floor	Minimum electric service	None

MODEL 452 - X ILLUSTRATIONS



MODEL 452 - X ILLUSTRATIONS



MODEL 453 - X HORSE ARENA

These structures include a simple clear span riding / exercise area with some stabling facilities. A good show or exhibit facility will have spectator viewing and lounge commensurate with the quality level. The spectator and lounge areas have concrete flooring. The better qualities have high-level lighting, horse washes, rest rooms, showers, finished stalls, and feed rooms. These units are generally not heated.

TYPE	EXTERIOR WALLS	INTERIOR FINISH	PLUMBING / ELECTRICAL	HEATING/COOLING
Excellent	Steel frame, good block or concrete panels, good enameled siding w/ masonry trim, good entrance	Finished stalls, lounge, viewing area, quality finishes	High-level electrical service, good rest rooms and kitchen	None
Good	Steel or wood frame, block, tilt-up, good siding, stucco or insulated sandwich panels, small entrance	Finished stalls, good floors in snack bars, feed/tack rooms, good quality throughout	Good lighting and water outlets, rest rooms	None
Average	Block, tilt-up, wood siding, stucco, good metal panels and roof, steel or wood frame, very plain, some interior finish	Unfinished arena area, floors in feed/tack room and washrooms	Adequate lighting and water service	None
Low Cost	Concrete block, vertical boards or plywood, metal siding, some wainscot	Minimum facility, some flooring	Minimum lighting and water service	None

MODEL 453 - X ILLUSTRATIONS



MODEL 454 - X HAY SHED / LIVESTOCK SHELTER

These structures are open shelters designed for the storage of hay or other materials. They are also used as livestock sunshades. They have wooden or steel roofs on either trusses or rafters. The primary support for the structure is either poles or posts and girders. Spans are generally wide. There are typically no walls and the floor is dirt.

TYPE	DESCRIPTION
Good	No walls or minimum walls, composition or steel gable roof on wood rafters and posts or steel columns, concrete floor, security lighting
Average	No walls or minimum walls, steel shed or flat roof on wood posts and girders or good steel posts, light slab floor, minimum electrical
Low Cost	No walls or minimum walls, light steel or fiberglass roof on light wood poles or metal pipes, asphalt or dirt floor, no electric

MODEL 454 - X ILLUSTRATIONS



MODEL 454 - X ILLUSTRATIONS



MODEL 454 - X ILLUSTRATIONS



MODEL 454 - X ILLUSTRATIONS



MODEL 455 - X HORSE STABLE

These are usually designed for the care and housing of horses. The better qualities are highly decorative and include stone, brick, brick veneer, or wood as the exterior finish. Interiors have finished stalls, rest rooms and quality finishes throughout. Good lighting and water service are also included.

The lower qualities use block or low-cost wood finishes on the walls and low-cost roof systems. Floors may be finished in only the feed and tack rooms with the remaining floors being dirt. Stalls are not finished and there is no lighting or plumbing.

The stable's size and needs of the owners influence the facilities that will be contained in the stable. Typically the following interior construction can be found: stalls or boxes, feed, tack, manure bunkers, and lavatory accommodations. The better qualities may also include a sick box, washing and cleaning room, a small office, and living quarters for stable hands.

TYPE	EXTERIOR WALLS	INTERIOR FINISH	PLUMBING / ELECTRICAL	HEATING/COOLING
Good	Good brick, block, best siding, good steel panels, some windows and ornamentation, finished inside	Finished stalls, good floors, concrete in feed and tack rooms, good quality throughout	Good lighting and water outlets, rest room	None
Average	Block, stucco, steel or wood siding, little trim, good roof, doors on stalls	Wainscot in stalls, concrete floors in tack and feed rooms	Adequate lighting and water outlets	None
Low Cost	Concrete block, boards on post and beam, metal on poles, galvanized steel, open stalls	Rough stalls, dirt floors	None	None

MODEL 455 - X ILLUSTRATIONS



MODEL 455 - X ILLUSTRATIONS



MODEL 456 - X QUONSET, AGRICULTURAL

A prefabricated metal building for agricultural applications having a semi-cylindrical roof of corrugated metal that curves down to the ground forming the exterior walls.

Component **YQC - Pre-Engineered Quonset, Rural (SF)** should be used with this model.

The cost includes concrete footings, a shell building with minimum fenestration and installation. Rank according to chart in Volume 2 component description.

The following components may be used to add interior construction, electric, and/or plumbing:

HAX	Interior Construction, Framed, Rural (SF - Floor Area)
HBX	Interior Construction, Masonry, Rural (SF - Floor Area)
IAX	Plumbing, Rural (SF - Floor Area)
LAX	Electric, Finished, Rural, Quonset (SF - Floor Area)
LBX	Electric, Unfinished, Rural, Quonset (SF - Floor Area)

MODEL 456 - X ILLUSTRATIONS



MODEL 456 - X ILLUSTRATIONS



MODEL 491 - 3 FEEDLOT

Use this model to value cattle feedlots.

Feedlots are enclosed areas designed to hold livestock, usually cattle, while they are fed and finished for market. They are usually equipped with pens for holding animals, mills or other facilities for preparing and delivering feed, watering facilities, dust and insect control devices, feed bunks, shades or shelters, and related equipment.

Commercial cattle feedlots in Arizona typically have a capacity of several thousand head of livestock. Animals consigned to a feedlot usually remain there for a period of up to several months.

The value of a feedlot is directly related to the maximum number of animals that can be handled in the feedlot at one time. Therefore, feedlots in Arizona have historically been valued by the cost method on the basis of their capacity expressed in “animal units.”



Feedlot improvements must be listed and entered into the construction cost system for calculation of values. **Form # 82366 (Cattle Feedlot Data Collection Form)** is used for that purpose.

Feedlot improvement values are based upon the cost approach as reflected in a value per “animal unit” capacity of the feedlot. For feedlot valuation, “animal unit” means the equivalent of one animal. The base feedlot component (**WXA**) cost includes the basic elements of feedlot construction listed below.

1. Wood feed trough
2. Neck rail
3. Water piping
4. Water trough

Components, which are not included with the base feedlot cost and must also be listed, are:

1. **WXB - Concrete feed trough**
2. **WXC - Concrete Aprons**
3. **WXD - Sun Shades**
4. **WXE – Succor Rod Post and Rail Corrals**
5. **WYG - Sprinklers**
6. **WXF - Asphalt Feed Lanes**
7. **WXI - Loading Chutes (EA)**
8. **WXH - Dip Tanks (LF of Tank)**

Examples of improvements that must be listed separately under the appropriate construction cost system model number are:

1. Office
2. Service building
3. Affixed mobile home
4. Blacktop
5. Exterior lighting
6. Railroad spur (if owned by the taxpayer)

Components WX(A, B, C, D, E, F, G, H and I) are based on per-animal unit and are a carry over from the previous construction cost system. The costs for these components are not updated annually and are several years out of date. Therefore, they are restricted to the feedlot model.

MODEL 491 - 3 ILLUSTRATIONS



MODEL 491 - 3 ILLUSTRATIONS



**ARIZONA DEPARTMENT OF REVENUE
CONSTRUCTION COST MANUAL**

**VOLUME I
APPENDIX A**

LISTING TECHNIQUES

TABLE OF CONTENTS

	PAGE
Portable Horse Stable	703
Warehouse, Cold Storage	706
Partial Complete Buildings	707
Warehouse Interior Finishes	710
Walk-in Cooler Boxes	712
Mobile Home / Recreational Vehicle Parks	713
Condominium	719
Floor Structure	721
Building with First Floor Parking on Grade	722
Miscellaneous Built-ins	723
Rammed Earth Structures	724
Neighborhood Shopping Centers and Strip Stores	725
Community Shopping Centers	727
Regional Shopping Centers	728
Convenience / Mini-Mart Market with Self-Service Gas	729
Clean Room Listing Procedure	730
Permanent Crop Listing Procedure	732
Baseline Factors	733
Procedures for Entering Mobile Homes into the Cost System (F.L.P.)	741
Car and Stop Elevator Listing Procedure	744
Square Foot Training Manual	745
Procedures for Entering Mobile Homes into the Cost System (S.F.)	829

PORTABLE HORSE STABLE

Typically, portable horse stables are characterized by a prefabricated metal channel frame, exterior walls of three-quarter inch plywood with galvanized steel interior panel, and painted metal siding on the exterior. Roofs are made of metal purlins with galvanized or painted steel cover. Interior stalls are typically 12 feet by 12 feet, each having a 4-foot sliding door with a bar top. There are numerous configuration and design options. Thus, portable horse stables should be listed using the following as a guide.

MODEL:	455-3	CLASS:	S
SITE PREP:		BC —100%	
FOUNDATION:		Use appropriate component—typically CAC (concrete open shell)—and rank accordingly.	
FRAME/STRUCTURE:		DNA —100% at rank 2	
WALLS:		MAY —100%	
		Use 4-sided perimeter—no deduction is needed for open breezeways. For painted metal exterior, use rank 2. For 2" tongue and groove wood exterior, use rank 4.	
ROOF STRUCTURE:		QSA —100% plus overhang	
		For purlins 6 feet on center, use rank 2.	
ROOF COVER:		RY —100% plus overhang	
FLOOR STRUCTURE:		Use appropriate component.	
FLOOR COVER:		Use appropriate component. Use model override if cover is in office area, living quarters, etc.	
INTERIOR CONSTRUCTION:		1 stall	HA—None
		2 stalls	HA—100% rank 0.5
		3 stalls	HA—100% rank 1.0
		4 or more stalls	HA—100% rank 2.0

The above rankings are based on **quantity** of partitions. Ranking for **quality** should follow the same guide used for exterior walls.

In large portable horse stables, it is common to have an office area or living quarters. These areas should be listed by the square foot with appropriate model override and rank. The remainder of the improvement square footage should be entered as HA with no model override.

CEILING:	Use appropriate component with model override as needed.
PLUMBING:	Use IA with model override as needed.
FIRE PROTECTION:	Use JA where applicable.
HEATING/COOLING:	Use appropriate components with model override as needed.
ELECTRICAL:	Use LA with model override as needed.

EXAMPLE 1

ARIZONA DEPARTMENT OF REVENUE
DETAILED VALUATION REPORT
CONSTRUCTION COST MODEL

CURRENT YEAR

"QUICK-CALC"

BASE FACTORS

MODEL: 4553	DESCRIPTION: HORSE STABLE	GRADE A CLASS: S
CONSTR: 1992	DEPREC. CODE: T7A06L35P01	PERCENT COMPLETE: 1.00
OBSOL: .00	MODERNIZATION: 1.00	PHYSICAL CONDITION: 1.00

GROUND FLOOR PERIM	AREA	TOTAL FLOOR AREA	NUMBER OF STORIES	PERCENT OWNERSHIP	AVG. STORY HEIGHT
00096	0000432	000000432	01.0	1.0000	8

COMPONENT COST ADJUSTMENT FACTORS

FOUNDATION: 1.0000 # OF STORIES: 0.9880 STORY HT: 0.9400 ARCH. FEE: 1.0416

COMPONENT LIST

COMP	TYPE	RANK	MISC.	UNITS	U/M	MODL	DESCRIPTION	COST	F	S
BC	03	2.0		100%	SFF		SITE PREPARATION	58	0	0
CACX	04	2.0		100%	SFF		CONCRETE, OPEN SHELL	231	1	0
DNA	05	2.0		100%	SFF		STEEL, PRE-ENGINEERED	669	0	1
MAY	06	2.0		100%	SFW		METAL COVER, STEEL	2332	0	0
QSA	09	2.0	1	100%	SFF		LIGHT PURLIN, OPEN	333	0	0
RY	10	2.0	1	100%	SFF		METAL, PREFORMED SHEET	538	0	0
HA	13	1.0		100%	SFF		INTERIOR CONSTRUCTION	525	0	1
POA	26	2.0		432	SF		AWNING, METAL	1578	0	0

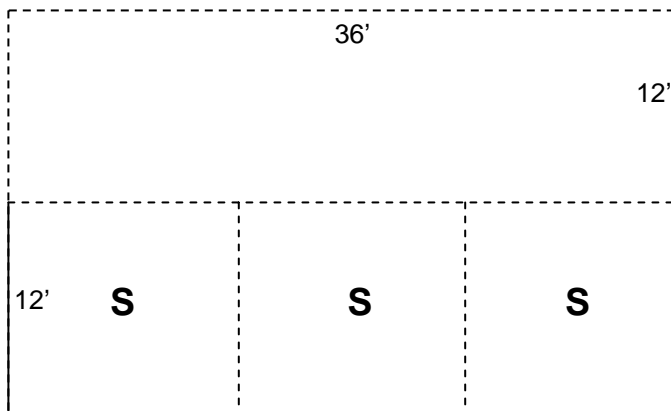

EXAMPLE 2

DETAILED VALUATION REPORT
CONSTRUCTION COST MODEL

CURRENT YEAR

"QUICK-CALC"

BASE FACTORS

MODEL: 4553	DESCRIPTION: HORSE STABLE	GRADE A CLASS: S
CONSTR: 1992	DEPREC. CODE: T7A06L35P01	PERCENT COMPLETE: 1.00
OBSOL: .00	MODERNIZATION: 1.00	PHYSICAL CONDITION: 1.00

GROUND FLOOR PERIM	AREA	TOTAL FLOOR AREA	NUMBER OF STORIES	PERCENT OWNERSHIP	AVG. STORY HEIGHT
00216	0002592	000002592	01.0	1.0000	8

COMPONENT COST ADJUSTMENT FACTORS

FOUNDATION: 1.0000	# OF STORIES: 0.9880	STORY HT: 0.9400	ARCH. FEE: 1.0416
--------------------	----------------------	------------------	-------------------

COMPONENT LIST

COMP	TYPE	RANK	MISC.	UNITS	U/M	MODL	DESCRIPTION	COST	F	S
BC	03	2.0		100%	SFF		SITE PREPARATION	347	0	0
CACX	04	2.0		100%	SFF		CONCRETE, OPEN SHELL	1387	1	0
DNA	05	2.0		100%	SFF		STEEL, PRE-ENGINEERED	4012	0	1
MAY	06	2.0		100%	SFW		METAL COVER, STEEL	5246	0	0
QSA	09	2.0	1	100%	SFF		LIGHT PURLIN, OPEN	2001	0	0
RY	10	2.0	1	100%	SFF		METAL, PREFORMED SHEET	3228	0	0
EB	11	2.0		11%	SFF		CONCRETE ON GROUND	566	0	0
FAH	12	2.0		11%	SFF	1513	VINYL COMPOSITION TILE	343	0	0
HA	13	2.0		89%	SFF		INTERIOR CONSTRUCTION	4553	0	1
HA	13	0.5		11%	SFF	1511	INTERIOR CONSTRUCTION	2030	0	1
GZ	14	2.0		11%	SFF	1513	GYPSTUM BOARD, SPRAYED ON	273	0	0
IA	15	2.0		89%	SFF		PLUMBING	688	0	0
IA	15	2.0		11%	SFF	1513	PLUMBING	745	0	0
KBM	17	2.0		11%	SFF	1513	INDIVIDUAL THRU-WALL	361	0	1
LA	18	2.0		89%	SFF		ELECTRICAL	878	0	0
LA	18	2.0		11%	SFF	1513	ELECTRICAL	1285	0	0

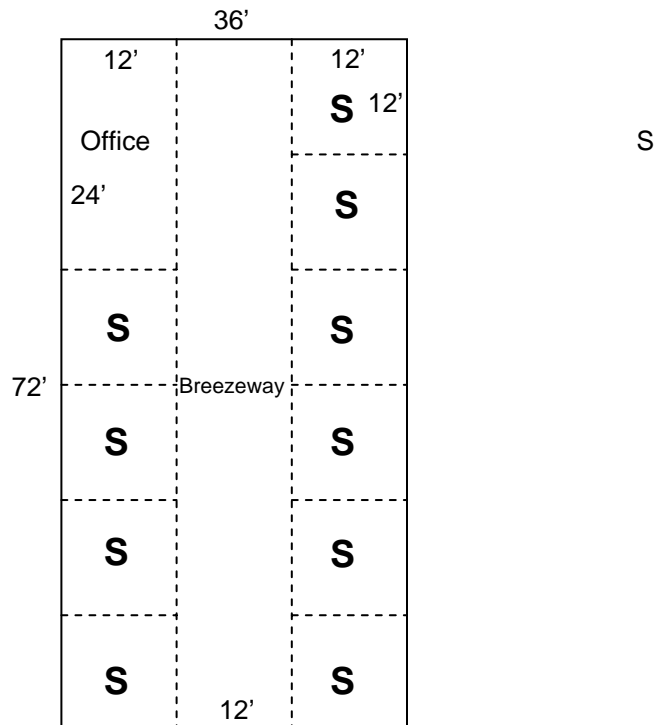

WAREHOUSE, COLD STORAGE

377-x

Cold storage warehouses are designed for storage of perishable goods. These structures are heavily insulated and usually have special cooling equipment. Cooling and ventilating facilities are sufficient to protect and maintain products at the desired temperature.

As in other warehouse-type improvements, the alternate interior method produces the most accurate value. For a complete discussion of this method, see the alternate interior listing procedure.

Heating and cooling should be added only for office, rest room, and any other area used for personnel. Cold storage area cooling equipment is personal property.

Exterior walls, roof, insulation, and floors are four areas that require special attention when listing this type of warehouse.

The exterior wall component cost includes both roll-up and pedestrian doors. Add downdraft system by using component **HQA** (air curtain). Exterior and interior cold storage doors, component **HZ** (metal clad hinged), should be added by the square foot of door area. Deduct the square footage of the door from the wall area. For exterior metal sandwich panel walls and roof, use **MBW** (sandwich panel wall) and **RX** (sandwich panel roof).

For segregated listings, use components **HX** (fiberglass or mineral wool batt) and **HY** (rigid) to list insulation for interior and exterior walls and roof. Place thickness in miscellaneous field. For sharp freeze temperatures (minus 15 and below), the typical thickness is 10 inches for HY and 14 inches for HX. For below freezing (minus 15 to 32), use 8 inches for HY and 11 inches for HX. For above freezing, use 4 inches for HY and 6 inches for HX.

For segregated listings, the added cost of cold storage warehouse floors is addressed through ranking of **EB** (concrete on ground), **EO** (insulation), and **EW** (foam concrete subfloor). For below freezing temperatures, use rank 4 on EB, EO, and EW. For above freezing cooler-type storage, use rank 2.

To list cold storage warehouses by the square foot method, see the square foot listing procedures in this appendix.

PARTIAL COMPLETE BUILDINGS

There are two methods to list a partial complete building. Of the two methods, selection is dependent upon the type of building and the estimate of how long it may remain incomplete.

1. The structure is a shell building, e.g., a loft or flex building, with minimum interior subdivisions. The estimated completion date is more than two tax years.
2. The structure is built as a complete unit (including interior) and will be completed within one tax year following the initial construction year.

Example 1

The building is listed as 100% complete on the baseline. Only the components (use unit or percentage) that actually exist in the building should be listed.

In the attached example, the interior construction, electrical, and plumbing components are not listed because these were not present. Only the components in existence at the time of appraisal are listed:

BC	Site preparation
CABX	Foundation
EB	Concrete floor
MG	Block exterior walls
QAA	Wood roof structure
RD	Built-up roof cover

In the first year, the building is 50% occupied—HA (interior construction), LA (electrical), and IA (plumbing) are listed at 50% complete. In the second year, the building is 100% occupied. The HA, LA, and IA are changed to 100%. The building is now considered complete.

Example 2

A structure is being built as a complete unit, e.g., a house, but will not be completed as of the date of appraisal. When this occurs, a partial complete percentage is determined. This can be accomplished by applying the percentages as shown in Section 2 or by listing the improvement in its entirety. This can be accomplished by dividing the cost of all components existing at the time of appraisal by the total RCN of the improvement. The components are listed as 100% complete even though they may not actually be in place at the date of appraisal.

In the following year, the structure is reviewed to ensure that it has been completed. If so, simply change the percent complete field from 50% to 100%. This would then complete the valuation procedure without the need to change the components.

Both methods produce similar values and both are technically correct procedures. Therefore, the main consideration is which method will allow the easiest and most accurate method of follow-up. In either situation, use review code 1 to show that the building needs review for the next tax year. This allows the county to receive a list of parcels that are partially complete and need a follow-up field check.

PARTIAL COMPLETE BUILDINGS

EXAMPLE 1

BASE FACTORS

MODEL: 3753	DESCRIPTION: LOFT	GRADE A CLASS: C
CONSTR: 1992	DEPREC. CODE: T4A06L60P00	PERCENT COMPLETE: 1.00
OBSOL: .00	MODERNIZATION: 1.00	PHYSICAL CONDITION: 1.00

GROUND FLOOR	TOTAL FLOOR	NUMBER OF	PERCENT	AVG. STORY
PERIM AREA	AREA	STORIES	OWNERSHIP	HEIGHT
00500 0010000	000010000	01.0	1.0000	18

COMPONENT COST ADJUSTMENT FACTORS

FOUNDATION: 1.0000 # OF STORIES: 0.9900 STORY HT: 1.1200 ARCH. FEE: 1.0580

COMPONENT LIST

COMP	TYPE	RANK	MISC.	UNITS	U/M	MODL	DESCRIPTION	COST	F	S
BC	03	2.0		100%	SFF		SITE PREPARATION	1781	0	0
CABX	04	2.0		100%	SFF		CONCRETE, BEARING WALL	19796	1	0
MG	06	2.0	8	100%	SFW		STANDARD BLOCK	95776	0	0
QAA	09	2.0	1	100%	SFF		WOOD JOISTS, WOOD DECK	31108	0	0
RD	10	2.0	1	100%	SFF		BUILT-UP COMPOSITION	13407	0	0
EB	11	2.0		100%	SFF		CONCRETE ON GROUND	27338	0	0

BASE FACTORS

MODEL: 3753	DESCRIPTION: LOFT	CLASS: C
CONSTR: 1992	DEPREC. CODE: T4A06L60P00	PERCENT COMPLETE: 1.00
OBSOL: .00	MODERNIZATION: 1.00	PHYSICAL CONDITION: 1.00

GROUND FLOOR	TOTAL FLOOR	NUMBER OF	PERCENT	AVG. STORY
PERIM AREA	AREA	STORIES	OWNERSHIP	HEIGHT
00500 0010000	000010000	01.0	1.0000	18

COMPONENT COST ADJUSTMENT FACTORS

FOUNDATION: 1.0000 # OF STORIES: 0.9900 STORY HT: 1.1200 ARCH. FEE: 1.0580

COMPONENT LIST

COMP	TYPE	RANK	MISC.	UNITS	U/M	MODL	DESCRIPTION	COST	F	S
BC	03	2.0		100%	SFF		SITE PREPARATION	1781	0	0
CABX	04	2.0		100%	SFF		CONCRETE, BEARING WALL	19796	1	0
MG	06	2.0	8	100%	SFW		STANDARD BLOCK	95776	0	0
QAA	09	2.0	1	100%	SFF		WOOD JOISTS, WOOD DECK	31108	0	0
RD	10	2.0	1	100%	SFF		BUILT-UP COMPOSITION	13407	0	0
EB	11	2.0		100%	SFF		CONCRETE ON GROUND	27338	0	0
HA	13	2.0		50%	SFF		INTERIOR CONSTRUCTION	14077	0	1
IA	15	2.0		50%	SFF		PLUMBING	8955	0	0
LA	18	2.0		50%	SFF		ELECTRICAL	17073	0	0

BASE FACTORS

MODEL: 3753	DESCRIPTION: LOFT	CLASS: C
CONSTR: 1992	DEPREC. CODE: T4A06L60P00	PERCENT COMPLETE: 1.00
OBSOL: .00	MODERNIZATION: 1.00	PHYSICAL CONDITION: 1.00

GROUND FLOOR	TOTAL FLOOR	NUMBER OF	PERCENT	AVG. STORY
PERIM AREA	AREA	STORIES	OWNERSHIP	HEIGHT
00500 0010000	000010000	01.0	1.0000	18

COMPONENT COST ADJUSTMENT FACTORS

FOUNDATION: 1.0000 # OF STORIES: 0.9900 STORY HT: 1.1200 ARCH. FEE: 1.0580

COMPONENT LIST

COMP	TYPE	RANK	MISC.	UNITS	U/M	MODL	DESCRIPTION	COST	F	S
BC	03	2.0		100%	SFF		SITE PREPARATION	1781	0	0
CABX	04	2.0		100%	SFF		CONCRETE, BEARING WALL	19796	1	0
MG	06	2.0	8	100%	SFW		STANDARD BLOCK	95776	0	0
QAA	09	2.0	1	100%	SFF		WOOD JOISTS, WOOD DECK	31108	0	0
RD	10	2.0	1	100%	SFF		BUILT-UP COMPOSITION	13407	0	0
EB	11	2.0		100%	SFF		CONCRETE ON GROUND	27338	0	0
HA	13	2.0		100%	SFF		INTERIOR CONSTRUCTION	31368	0	1
IA	15	2.0		100%	SFF		PLUMBING	17911	0	0
LA	18	2.0		100%	SFF		ELECTRICAL	34146	0	0

PARTIAL COMPLETE BUILDINGS

EXAMPLE 2

BASE FACTORS

MODEL: 0103	DESCRIPTION: SINGLE FAMILY DWELLING GRADE A	CLASS: D
CONSTR: 1992	DEPREC. CODE: T2A06L60P00	PERCENT COMPLETE: 0.50
OBSOL: .00	MODERNIZATION: 1.00	PHYSICAL CONDITION: 1.00

GROUND FLOOR PERIM	GROUND FLOOR AREA	TOTAL FLOOR AREA	NUMBER OF STORIES	PERCENT OWNERSHIP	AVG. STORY HEIGHT
00189	0001961	0000001961	01.0	1.0000	8

COMPONENT COST ADJUSTMENT FACTORS

FOUNDATION: 1.0000 # OF STORIES: 0.9880 STORY HT: 1.0000 ARCH. FEE: 1.0560

COMPONENT LIST

<u>COMP</u>	<u>TYPE</u>	<u>RANK</u>	<u>MISC.</u>	<u>UNITS</u>	<u>U/M</u>	<u>MODL</u>	<u>DESCRIPTION</u>	<u>COST</u>	<u>F</u>	<u>S</u>
BC	03	2.0		100%	SFF		SITE PREPARATION	286	0	0
CAEX	04	2.0		100%	SFF		CONCRETE, SIDING/ST	3008	1	0
MAI	06	2.0		100%	SFW		STUCCO	14229	0	0
MAU	06	2.0		100%	SFW		INSULATION	615	0	0
QAA	09	2.0	3	106%	SFF		WOOD JOISTS, WOOD DECK	6052	0	0
QAA	09	2.0	3	401	SFF		WOOD JOISTS, WOOD DECK	1167	0	0
RF	10	2.0	3	106%	SFF		COMPOSITION SHINGLE	2082	0	0
RF	10	2.0	3	401	SFF		COMPOSITION SHINGLE	402	0	0
EB	11	2.0		100%	SFF		CONCRETE ON GROUND	4297	0	0
FAB	12	2.0		20%	SFF		VINYL SHEET	863	0	0
FE	12	2.0		80%	SFF		CARPET AND PAD	2699	0	0
HA	13	2.0		100%	SFF		INTERIOR CONSTRUCTION	21033	0	1
GH	14	2.0		100%	SFF		GYP SUM BOARD, TAPED	1903	0	0
GW	14	2.0		100%	SFF		CEILING INSULATION	1003	0	0
IA	15	2.0		100%	SFF		PLUMBING	6649	0	0
KQ	17	2.0		100%	SFF		HEAT PUMP	6220	0	0
LA	18	2.0		100%	SFF		ELECTRICAL	4358	0	0

WAREHOUSE INTERIOR FINISHES

There are three methods—square feet of floor, alternate, and modified alternate—available for listing the interiors of warehouses.

Alternate Method

The alternate method is based on a cost for each square foot of partitioned wall area and accounts only for the basic wall, the finish on that wall, and the windows, doors, and other wall openings (fenestration). If this method is used, consideration must also be given to components that are not included with the basic wall partitions, e.g., cabinets, stairs, toilet partitions, and so forth. To list an improvement using the alternate method, do the following:

1. Measure the square feet of floor for the office area. List the square feet of floor and the appropriate model override.
2. Measure the square feet of wall for all other partitions. These may include rest rooms, lunchroom, mezzanine storage, and so forth. Use the warehouse model override.
3. Ceiling finish and floor cover also need to be added for the office area. List the square feet for each and the appropriate model override.
4. For plumbing, count all fixtures, e.g., water closets, lavatories, urinals, janitor sinks and so forth, drains and grease traps, drinking fountains, and refrigerated water coolers.
5. Other components that may also need a model override are heating/cooling and electrical.

Modified Alternate Method

Use the attached example as a guide to list the interior components. If interior partitions other than rest rooms are located in the override area, model 151-x should be considered instead of 111-x. The construction grade of the override should be reviewed to determine how the actual interior construction compares in quality and quantity with the construction typical of the override model. When using this procedure, do not list any additional HA for the remainder of the improvement. Doing so will add an additional percentage of interior for office, break areas, rest rooms, and will result in overvaluation.

To list the plumbing, use the fixture count. Fixtures physically clustered in the main override area will have common water and sewer runs and should carry the model override. Fixtures physically distant from the override area will have separate runs and should be listed with no override.

If interior inspection is not possible, enter HA, IA, and LA at 100%. Include a comment in the remarks and list [review code 4](#).

WAREHOUSE INTERIOR FINISHES

Modified Alternate Method Example

COMPONENT TYPE	CODE	UNITS	MODEL OVERRIDE	COMMENTS
Interior	HA	960 SF	111-x	Includes 60 SF of rest rooms in warehouse and breakrooms.
Interior Partitions	HL HH HO HR	1920 SF	None	100' x 16' = 1,600 SFW 20' x 16' = 320 SFW
Ceiling	Code	960 SF	111-x	Indicate ceiling in warehouse, if any, without override.
Plumbing Fixtures	IB IB	5 EA 2 EA	111-x None	
Heating and Cooling	Code Code	960 SF *5400 SF	111-x None	
Electrical	LA LA	960 SF *5400 SF	111-x None	
Floor Cover	Code	960 SF	111-x	Indicate floor cover in warehouse, if any, without override.

*The building contains normal electrical and heating-cooling over the office area. Therefore, these components are listed at 100% of warehouse even though this appears to be a duplication.

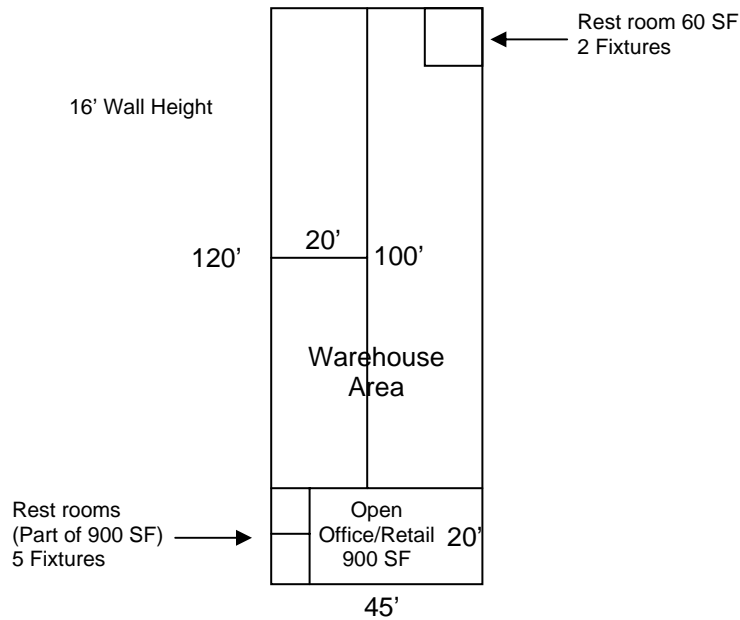

WALK-IN COOLER BOXES

Interior Components (HA—HB—HANC—HSFC—HZW)

Walk-in cooler boxes are included in the segregated system interior components codes (HA and HB) for supermarkets, convenience stores, mini-mart convenience stores, restaurants, fast food restaurants, truck stops, bars, drugstores and taverns. Use interior component HANC to exclude the cost of these walk-in coolers. Walk-in cooler boxes are not included in the square foot system base component for these models. Adding component HSFC (built-in coolers) to the square foot listing will add the cooler cost. Cooler doors are not included in HA, HB or the square foot base component. Use HZW for each cooler door in addition to the HA, HB or square foot base component if cooler cost is desired. Display coolers and freezers are not included and are considered to be personal property.

All items included in the Marshall & Swift calculator or square foot system are also included in the interior components (HA and HB) of the segregated cost system. When in doubt, consult the appropriate section of the Marshall Valuation Service manual for the description. If this manual is not available, call the Department of Revenue, Property Tax Division to obtain a copy of the descriptions.

Drawing Legend:

- (1) Included with interior components (HA and HB), except cooler doors (HZW).
- (2) Personal property.
- (3) Personal property.

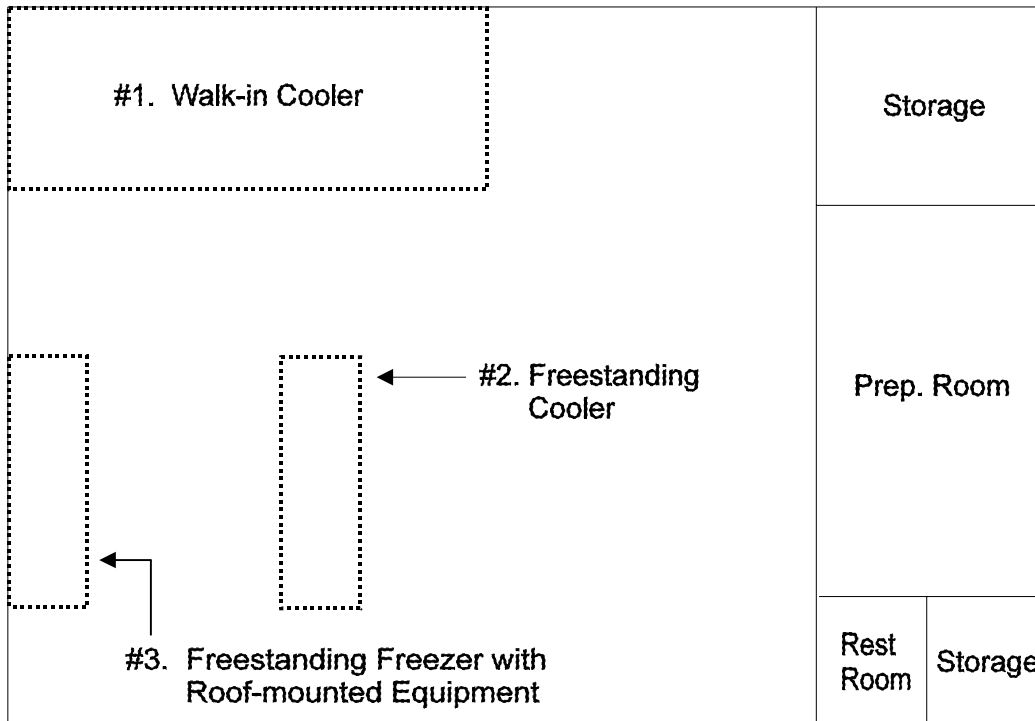

MOBILE HOME / RECREATIONAL VEHICLE PARKS

A mobile home park leases or rents spaces to mobile home owners. The spaces, amenities, and available facilities may differ greatly from park to park. Many mobile home rental parks have extensive recreational vehicle facilities.

Recreational vehicle (RV) parks provide elaborate recreational facilities often with parklike settings, and are designed for easy parking and removal of motor homes, campers, and trailers.

A space is the area within the park designated for each mobile home—recreational vehicle. The park spaces may include single-wide, double-wide, recreational vehicle, or any combination of the three. Also included are hookups for electric, water—sewer, water—septic, gas service, and concrete pads. The sidewalk and street in front of each space are considered part of the space cost. An alternative to including the sidewalk and street with the lot is to list these with the concrete and asphalt for the entire park.

Clubhouses and recreational buildings are listed on the commercial data collection form using the appropriate model number. Miscellaneous yard improvements such as parking lots—streets—sidewalks, spas—swimming pools, tennis courts, and other common area facilities are listed separately from the park spaces on the mobile home—recreational vehicle park data collection form.

When valuing mobile home—recreational vehicle parks by the construction cost method, the process requires that each component be listed separately and graded accordingly. There is no need to grade the entire park based on the amenities. These are graded individually if present.

INSTRUCTIONS TO COMPLETE THE MOBILE HOME / RECREATIONAL VEHICLE PARK DATA COLLECTION FORM (DOR 82368). Always complete a separate data collection form for each type of space.

YARD IMPROVEMENTS FOR EACH RENTAL SPACE:

Electrical Service—**MHE**. One for each type of space (single, double, or RV) times the number of similar spaces in the park. Quality may be adjusted by cost rank.

Water and Sewer—**MHW**. Same as electrical service.

Water and Septic—**MHA**. Same as electrical service.

Septic Treatment, Private System – **MHX**. Add in addition to MHA. One for each space times the number of similar spaces in the park. Cost rank decreases with quantity.

Sewage Treatment, Private System – **MHT**. Add in addition to MHW. One for each space times the number of similar spaces in the park. Cost rank decreases with quantity.

Gas Service—**MHG**. Same as electrical service.

Water and Electric—**MTT**. One for each recreational vehicle space times the number of similar spaces in the park. Quality may be adjusted by cost rank.

Water Service—**MTW**. Same as water and electric (MTT).

Site Preparation—**MHP**. Total square feet of lot including the sidewalk and one-half of the street in front of the lot times number of similar spaces in the park. Or, list the sidewalks and streets with the yard improvements for the entire park. Quality may be adjusted by cost rank.

Concrete—**PCUM** or **PCU**. Concrete paving for slabs, sidewalks, and drives for each type of space times number of similar spaces in the park. Quality may be adjusted by cost rank.

Asphalt—**PASM** or **PAS**. Asphalt paving and base for streets and drives for each type of space times number of similar spaces in the park. Quality may be adjusted by cost rank.

Curbing: Asphalt—**PACM** or **PAC**; Concrete—**PCCM** or **PCC**. Total linear feet of curbing for each type of space times number of similar spaces in the park. Quality may be adjusted by cost rank.

YARD IMPROVEMENTS FOR THE ENTIRE PARK:

The miscellaneous yard improvements for the entire park are listed in this section. Or, use a separate data collection form (DOR 82360Y) if the yard improvements are extensive. Components such as fencing, park lighting, swimming pools—spas, parking lots, or other common area amenities not included with the yard improvements for each rental space are listed here or on a separate form.

For paved areas of 100,000 square feet and larger, ADD site preparation (BC), e.g., streets, parking lots, etc.

Structures such as the clubhouse or other recreational buildings are to be listed on the commercial data collection form using the appropriate model number. Listed below is a combination of forms that may be used.

<u>IMP. NO.</u>	<u>TYPE OF IMPROVEMENT</u>	<u>DOR FORM NO.</u>
1 of 6	Double-wide spaces	82368 
2 of 6	Single-wide spaces	82368
3 of 6	RV or overnight spaces	82368
4 of 6	Clubhouse or recreational building	 82360
5 of 6	Laundry building	82360
6 of 6	Yard improvements (pool, spa, parking lot, sidewalks, fencing, tennis courts, etc.)	82368 or 82360Y 

Attached are examples of completed data collection forms with a drawing illustrating the above listing procedure for single-wide and double-wide lots in a mobile home rental park.

EXAMPLE

MOBILE HOME PARK
100 SINGLE-WIDE LOTS
100 DOUBLE-WIDE LOTS

Not to scale

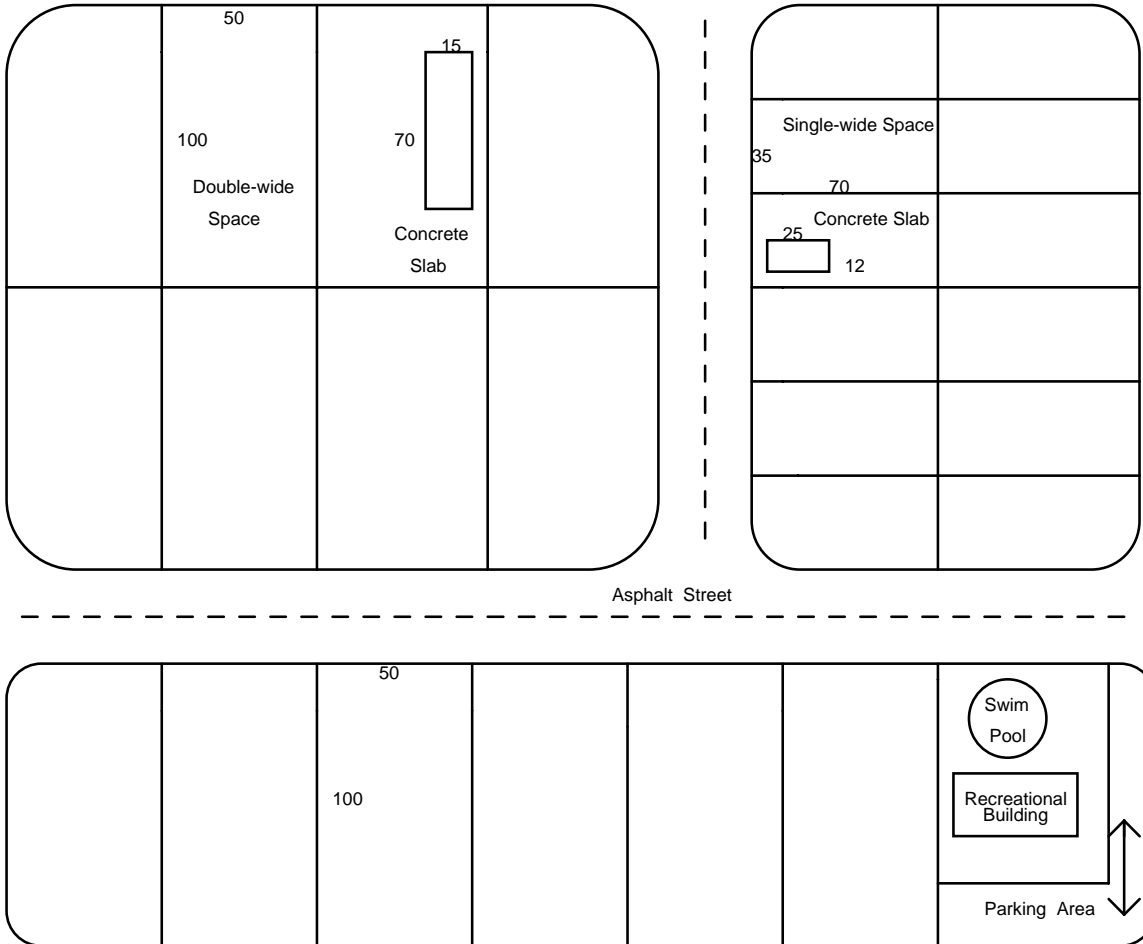

Calculation example for single-wide lots:

$$\begin{array}{r}
 \text{Mobile home lot:} \quad 70 \text{ feet} \\
 \text{One-half of street:} \quad + \underline{15 \text{ feet}} \\
 \hline
 85 \text{ feet} \quad \times \quad 35' \quad = \quad 2,975 \text{ sq. ft.}
 \end{array}$$

OR, Total land: 595 feet x 500 feet = 297,500 sq. ft. ÷ 100 = 2,975 sq. ft.

OR, Combine the sidewalk and street with the miscellaneous yard improvements.

Calculation example for double-wide lots:

$$\begin{array}{r} \text{Mobile home lot:} \quad 100 \text{ feet} \\ \text{One-half of street:} \quad + \text{ 15 feet} \\ \hline 115 \text{ feet} \end{array} \times 50' = 5,750 \text{ sq. ft.}$$

OR, Total land: 822 feet x 700 feet = 575,400 sq. ft. \div 100 = 5,754 sq. ft.

OR, Combine the sidewalk and street with the miscellaneous yard improvements.

ALWAYS COMPLETE A SEPARATE MOBILE HOME AND RECREATIONAL VEHICLE DATA COLLECTION FORM FOR EACH TYPE OF LOT, e.g., single-wide or double-wide or recreational vehicle.

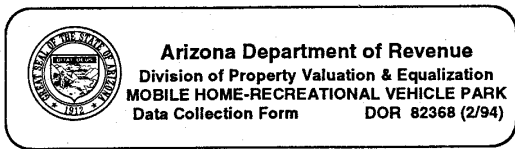

Parcel _____
 Co. _____ Book _____ Map _____ Parcel _____ S _____ C _____
 Imp. _____ of _____ Section _____ of _____ IPR
 Situs _____ City _____

SINGLE-WIDE SPACES

Appraiser SAMPLE Appraisal Date / / Reviewed By _____ Date / /

Model	CCI	Perimeter	No. Rental Spaces		No. of Stories	Avg. Sty. Hgt.	Const. Year	Percent Complete	Percent Ownership	Note in Remarks			
			This Imp.	Total Park						OBS:	MOD:	PHY:	
281 -	D	1			1	1		*Review	0.	%	1.	%	%
YARD IMPROVEMENTS (36)													
Site improvements for each rental space.										Component Code	Cost Rank	No. of Spaces	Units
Electrical Service (EA space)										MHE		100	1
Gas Service (EA space)										MHG		100	1
Water and Electrical Service, RV Park (EA space)										MTT			
Water Service, RV Park (EA space)										MTW			
Water and Septic (EA space)										MHA			
Water and Sewer (EA space)										MHW		100	1
Septic Treatment, Private System (ADD; EA space)										MHX			
Sewage Treatment, Private System (ADD; EA space)										MHT			
Site Preparation (SF of lot)										MHP		100	2975
Concrete, Unreinforced (SF paved area)										PCUM		100	340
Asphalt (SF paved area)										PASM		100	525
(OR LIST WITH YARD IMPS FOR PARK)													

Model	CCI	Perimeter	Square Footage		No. of Stories	Avg. Sty. Hgt.	Const. Year	Percent Complete	Percent Ownership	Note in Remarks			
			Gr. Level	Total						OBS:	MOD:	PHY:	
101 -	D	1	1	1	1	1		*Review	0.	%	1.	%	%
YARD IMPROVEMENTS (36)													
USE THIS SECTION FOR THE COMMON AREA COMPONENTS													
Site improvements for entire park.										Imp. _____ of _____			
										Component Code	Cost Rank	Units	
Paving and Sidewalks										Landscaped Area			
Asphalt (SF paved area)										PAS		100,000	
Concrete, Unreinforced (SF paved area)										PCU			
Site Preparation (SF)										BC		100,000	
										Tennis Courts			
Curbing													
Asphalt (LF)										PAC		3,500	
Concrete (LF)										PCC			
										Park Fencing**			
Concrete Block (SFW)										WAC			
Wood, Solid Board (LF)										WFA			
										Miscellaneous			
										Trash Enclosure (EA)			
										TRE			
Park Lighting													
Fluorescent Lights without pole (EA)										LF			
Sodium/Mercury Vapor without pole (EA)										LG			
Light Poles for above lights (LF)										LH			
Swimming Pools													
Gunitite (SF pool area)										SPK			
Poured Concrete (SF pool area)										SPC		900	
										NOTE			
										Use 82360 for models such as:			
Spas													
Attached to Pool (EA)										SPA		1	
Detached (EA)										SPR			
										Clubhouse (272-x)			
										Recreational Building (282-x)			
										Laundry Building (102-x)			
										Rest Room Building (103-x)			
** Refer to component description for cost rank.										Refer to manual for complete list of models.			

REMARKS: _____ *Review Code _____

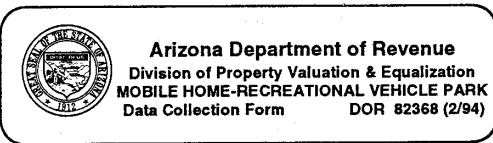

Parcel _____
 Co. _____ Book _____ Map _____ Parcel _____ S _____ C _____
 Imp. _____ of _____ Section _____ of _____ IPR
 Situs _____ City _____

DOUBLE-WIDE SPACES

Appraiser SAMPLE Appraisal Date ___/___/___ Reviewed By _____ Date ___/___/___

Model	CCI	Perimeter	No. Rental Spaces		No. of Stories	Avg. Sty. Hgt.	Const. Year	Percent Complete	Percent Ownership	Note in Remarks			
			This Imp.	Total Park						OBS:	MOD:	PHY:	
281-	D	1			1	1		*Review	0.	%	1.	%	%
YARD IMPROVEMENTS (36) Site improvements for each rental space.										Component Code	Cost Rank	No. of Spaces	Units
Electrical Service (EA space)										MHE		100	1
Gas Service (EA space)										MHG		100	1
Water and Electrical Service, RV Park (EA space)										MTT			
Water Service, RV Park (EA space)										MTW			
Water and Septic (EA space)										MHA			
Water and Sewer (EA space)										MHW		100	1
Septic Treatment, Private System (ADD; EA space)										MHX			
Sewage Treatment, Private System (ADD; EA space)										MHT			
Site Preparation (SF of lot)										MHP		100	5750
Concrete, Unreinforced (SF paved area)										PCUM		100	1057
Asphalt (SF paved area)										PASM		100	1500
<i>(OR LIST WITH YARD IMPS FOR PARK)</i>													

Model	CCI	Perimeter	Square Footage		No. of Stories	Avg. Sty. Hgt.	Const. Year	Percent Complete	Percent Ownership	Note in Remarks								
			Gr. Level	Total						OBS:	MOD:	PHY:						
101-	D	1	1	1	1	1		*Review	0.	%	1.	%	%					
USE THIS SECTION FOR THE COMMON AREA COMPONENTS										Imp. _____ of _____								
YARD IMPROVEMENTS (36) Site improvements for entire park.										Component Code	Cost Rank	Units	Component Code	Cost Rank	Units			
Paving and Sidewalks										Landscaped Area								
Asphalt (SF paved area)										PAS			Desert/Grass (SF Area)			LAM		
Concrete, Unreinforced (SF paved area)										PCU			Lawn (SF Area)			LAB		
Site Preparation (SF)										BC								
Curbing										Tennis Courts								
Asphalt (LF)										PAC	3500		Asphalt Court (EA)			TCA		
Concrete (LF)										PCC			Concrete Court (EA)			TCC		
										Tennis Court Fencing (EA Court)						TCF		
										Tennis Court Lighting (EA Court)						TCL		
Park Fencing**										Miscellaneous								
Concrete Block (SFW)										WAC			Trash Enclosure (EA)			TRE		
Wood, Solid Board (LF)										WFA								
Park Lighting																		
Fluorescent Lights without pole (EA)										LF								
Sodium/Mercury Vapor without pole (EA)										LG								
Light Poles for above lights (LF)										LH								
Swimming Pools																		
Gunitite (SF pool area)										SPK								
Poured Concrete (SF pool area)										SPC								
Spas										NOTE								
Attached to Pool (EA)										SPA			Use 82360 for models such as:					
Detached (EA)										SPR			Clubhouse (272-x)					
										Recreational Building (282-x)								
										Laundry Building (102-x)								
										Rest Room Building (103-x)								
** Refer to component description for cost rank.										Refer to manual for complete list of models.								

REMARKS: _____ *Review Code _____

CONDOMINIUM AND TOWNHOUSE

The method of listing condominiums or townhouses is the same for residential, commercial, and industrial. The most common form of condominium ownership is to hold title to individual units within a structure and have an undivided interest in the common areas that is typically maintained by an association.

To list, first identify the structure in which the individual condominiums or townhouses are located. Then, follow the same procedure for completing the listing form as for any other improvement; i.e., full exterior perimeter; total square footage including any common areas inside the structure such as rest rooms, hallways, elevators, or stairs; and all other components present in the entire structure. If the complex has more than one structure devoted to condominiums, address each structure separately.

To determine the proportional interest each unit owner has in the structure as well as the common areas, examine the ownership documents or the conditions, covenants, and restrictions (CCR). If the proportional interest is based on other than square footage, use the specified interest expressed as a decimal (Example 1). If the allocation is to be based on square footage, compute the ratio of individual unit area to total of all units area, excluding the common areas within the building (Example 2). Enter the factor in the common area allocation (percent ownership) field of the base factor line and identify it as improvement 1. The value produced will be for the entire structure with a percentage allocated to the individual owner.

If there is more than one structure with individual units, complete a separate data collection form for each parcel. The total percent ownership factors for all the units in the entire structure must be equal to 1.00. This same procedure should be used for the common area allocation for clubhouses, parking lots, swimming pools, or other site improvements. The allocation factors for the common areas may be different from the allocation factors for the structure with the individual units. For example, if there are two or more structures with individual units, the allocation factor for the common area in most cases would be different from the allocation for the individual units.

An alternative method of ownership of the common areas is for the developer or other entity to own and operate all or part of the common areas. If all or part of the common areas is separately parceled to another entity, the supplemental data collection form (**DOR 82370**) may be completed. In this instance, no common area allocation factor need be entered in the percent ownership field on the base factor line since the ownership is considered to be 100%. Only the area collectively owned by the individual unit owners should be allocated as discussed above.



EXAMPLE 1

IMPROVEMENT 1:

Parcels A and B:
 $1,250 \div 5,000 = 0.25$ ownership

Parcel C:
 $2,500 \div 5,000 = 0.50$ ownership

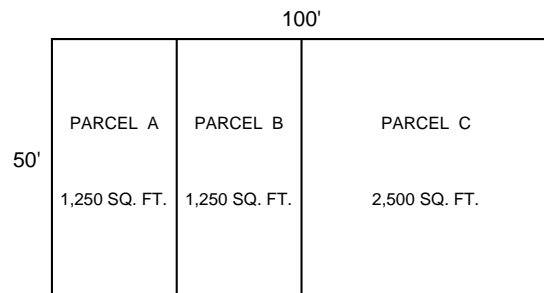

IMPROVEMENT 2: Yard improvements such as asphalt parking lot, curbing, sidewalks, landscaping. Each parcel has a 0.3333 ownership factor based on the legal description.

EXAMPLE 2

IMPROVEMENT 1:

Total square feet: 5,000
 (Enter on base factor line.)

Total square feet for
 ownership calculation: 4,750
 (Do not include common hallway)

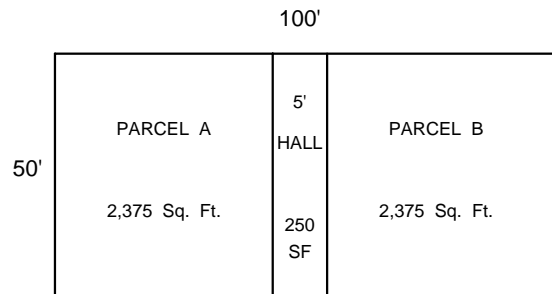

Ownership Factor:

Parcel A: $2,375 \div 4,750 = 0.50$

Parcel B: $2,375 \div 4,750 = 0.50$

FLOOR STRUCTURE

The floor structure, including thickness, is priced in accordance with the typical requirements for the live/dead load of each model. For example, the floor structure requirement for an office building is much different from the floor structure of a distribution warehouse. The component cost reflects the difference between these two types of floor structures. However, for floor structures that are not typical for a specific model, the following schedule may apply:

<u>Inch Thickness</u>	<u>Cost Rank</u>
Up to 4	1
4–6	2
8	3
10–12	4

For floor structures over 12 inches, the square footage of the floor area should be doubled. For example, a warehouse with 100,000 square feet may have a 16-inch thick floor to accommodate heavy equipment. Adjust for the extra thickness by using cost rank 3 and 200,000 square feet for the floor structure component.

BUILDING WITH FIRST FLOOR PARKING ON GRADE

List the building as a multiple story improvement using the appropriate model number. Include the square footage of the first floor parking in the ground floor area and in the total floor area. If the parking area is enclosed, no adjustment is needed for the exterior wall component. If the parking area is open, deduct the appropriate square footage of wall area from the exterior wall component. These buildings will typically be class A (structural steel frame) or class B (reinforced concrete frame). The frame is listed as 100% complete.

Deduct the parking area square footage from any interior component that is not present in the parking area. Some examples may include interior construction, heating/cooling, or plumbing. If a component is present—for example, sprinklers or elevators—the parking area square footage should be included.

List the floor of the parking area with the yard improvements. For instance, if the floor is asphalt, include the area with other asphalt that may be on the site.

MISCELLANEOUS BUILT-INS APARTMENTS

Currently, when utilizing the income approach to value apartment buildings, the items normally considered as personal property, such as the appliances, are considered part of the income stream. In many apartment buildings the appliances—refrigerators, ranges and ovens, garbage disposals, dishwashers, range hoods, trash compactors, microwaves, built-in mixer units and so forth—are included as part of the lease agreement. These items contribute to the income stream when the property is valued by the income approach.

As such, these should be accounted for in the cost approach. To correlate the cost value with the income value for the property, these items should be included when listing the components for an apartment building. The components for the appliance package (**APP**), refrigerator (**UM**), clothes washer (**APPW**), clothes dryer (**APPD**), and clothes washer–dryer combination (**APPC**) are found in **component type 21**, miscellaneous built-in construction. Once these components have been listed on the cost system and are on the real property tax roll, then the items need not be reported as personal property.

The exception to the above is any furniture that may be part of the lease agreement. The income is adjusted to exclude furniture when apartments are rented furnished. A personal property statement is required to carry this item as personal property.

RAMMED EARTH STRUCTURES (015-x)

Rammed earth structures feature exterior masonry walls made of a compressed mixture of earth, aggregate, and Portland cement. The walls commonly vary from 18 to 36 inches in thickness. Because of the unusual thickness of these walls, the square footage should be determined based on a typical 8-inch masonry wall thickness. For example, if the walls are 24 inches thick, 16 inches should be subtracted from the side of each wall when calculating the square footage.

This drawing of a rammed earth single family residence (015-x) has 24-inch walls. The calculation for the square footage is as follows:

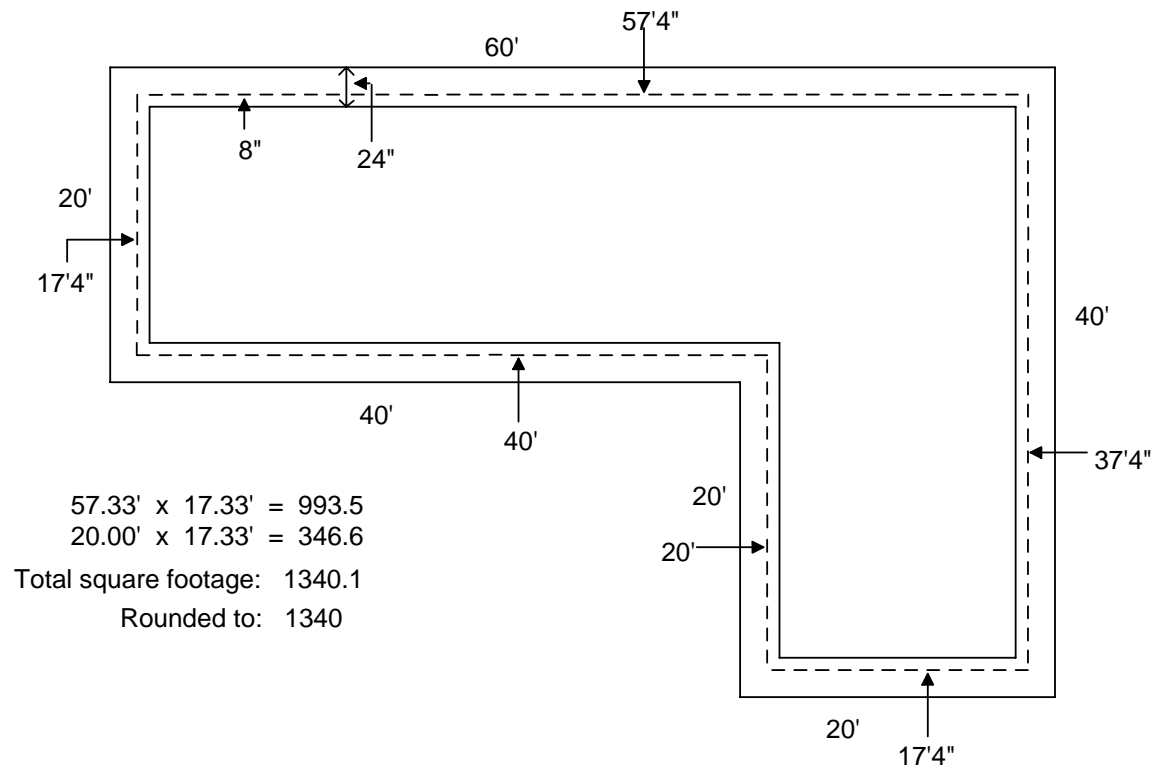

NOTE: Consider these two points: (1) It is advantageous to produce a drawing like the example with the actual and adjusted wall measurements. This shows the measurements used to calculate the square footage. Furthermore, not all wall measurements need to be adjusted. Note the walls forming the inside corner of the structure. (2) When calculating the perimeter, use the actual exterior measurements of the rammed earth walls. If the deducted wall measurements are used for the perimeter, the cost of the exterior walls will be calculated under cost for components WW (Rammed earth, commercial) or WX (Rammed earth, residential).

NEIGHBORHOOD SHOPPING CENTERS AND STRIP STORES

Neighborhood Shopping Centers (141 - X) and Strip Stores (114 - X) may or may not have anchor tenants. Anchors should be listed separately using the appropriate model number. For all of the examples below, site (and any site improvements such as parking lots) should be listed as a separate improvement. For instance, the shopping center would be improvement 1 of 2 and the site would be improvement 2 of 2.

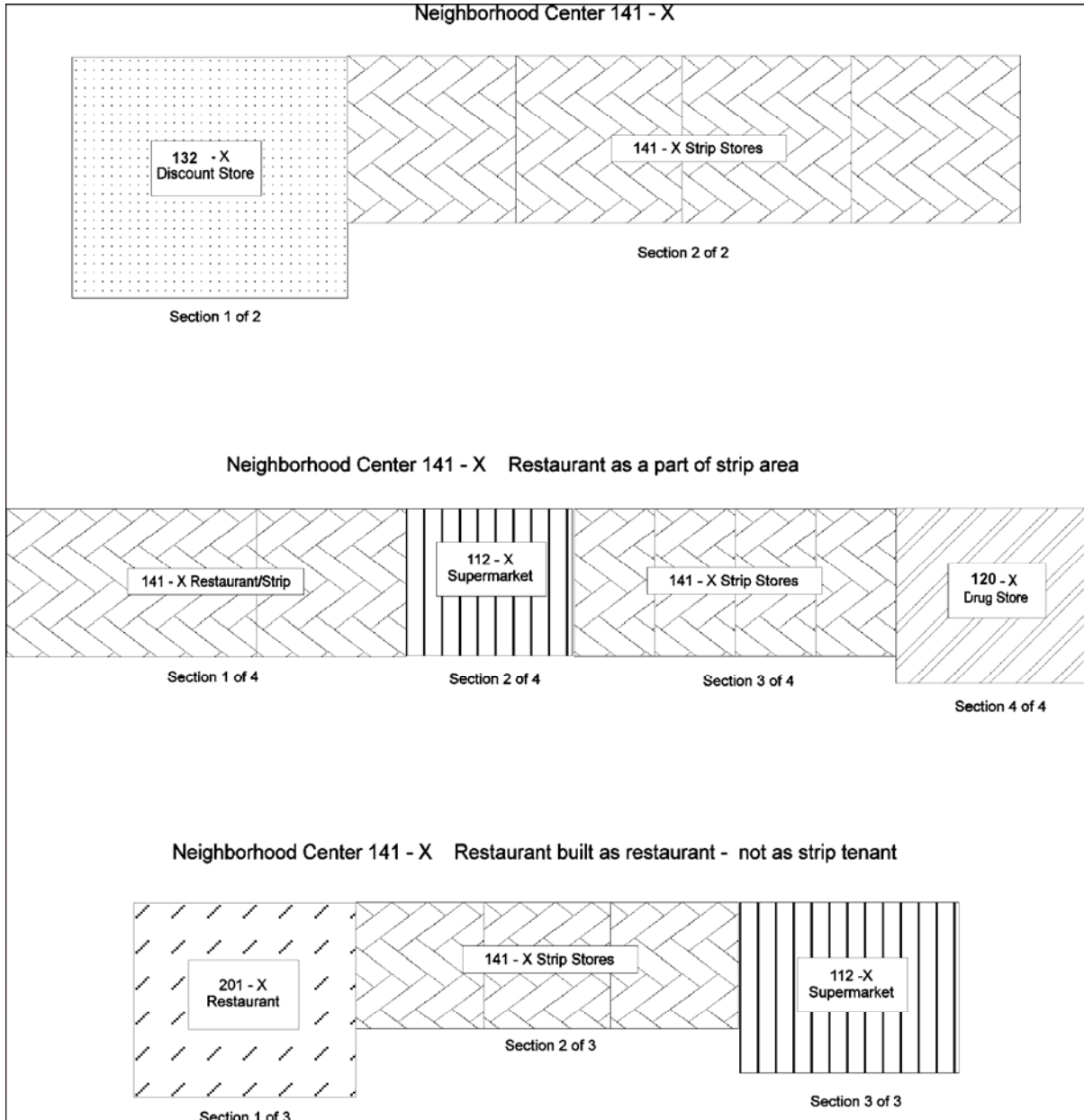

NEIGHBORHOOD SHOPPING CENTERS AND STRIP STORES

Strip Store 114 - X No anchor - Restaurant in 2 spaces by removing wall

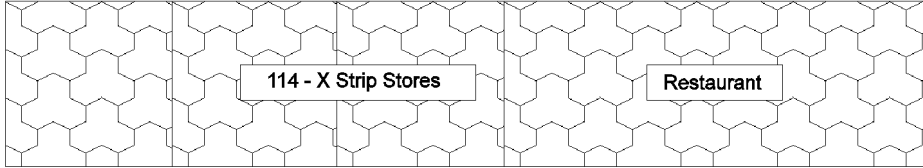

Section 1 of 1

Strip Store 114 - X No anchor - Restaurant originally designed as part of strip

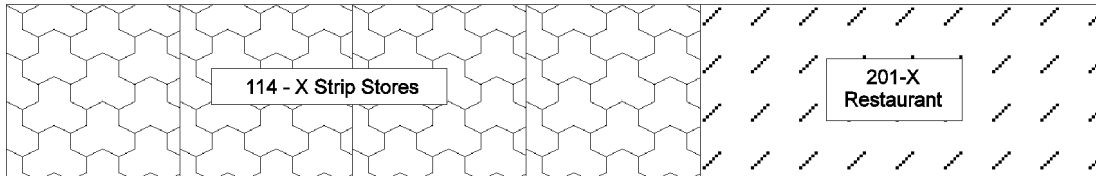

Section 1 of 2

Section 2 of 2

COMMUNITY SHOPPING CENTERS

Community Shopping Centers (142 - X) consist of several anchor tenants along with a large number of various types of smaller stores adjoining an enclosed HVAC or open air mall area. These centers are higher quality in design and larger in size than the neighborhood shopping centers. Anchor improvements are listed separately using the appropriate model number.

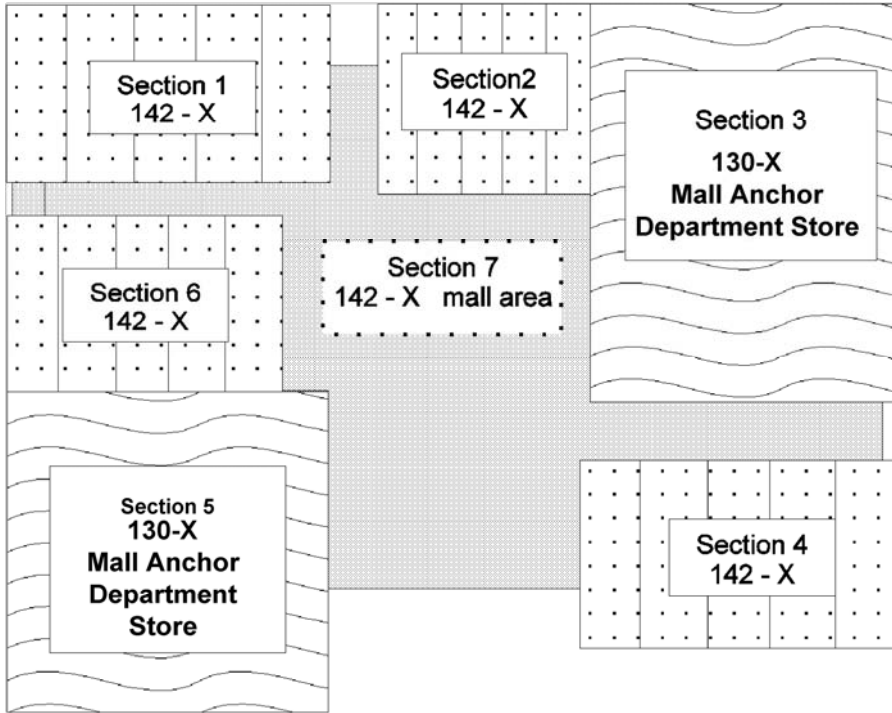

REGIONAL SHOPPING CENTERS

Regional shopping centers consist of a large number of various types of stores which adjoin a multilevel HVAC mall area with several anchor tenants also opening into the mall area. These malls usually have escalators and/or elevators. Anchor stores are listed separately using the appropriate model number. In the example below, the mall area is picked up as a separate section, with the 2nd level as balcony with appropriate stairways, escalators, etc. Common walls are assigned to the larger stores; storefront is assigned to each section as appropriate. Storefront of entrances is assigned to mall area section. Anchor improvements are listed separately using the appropriate model number.

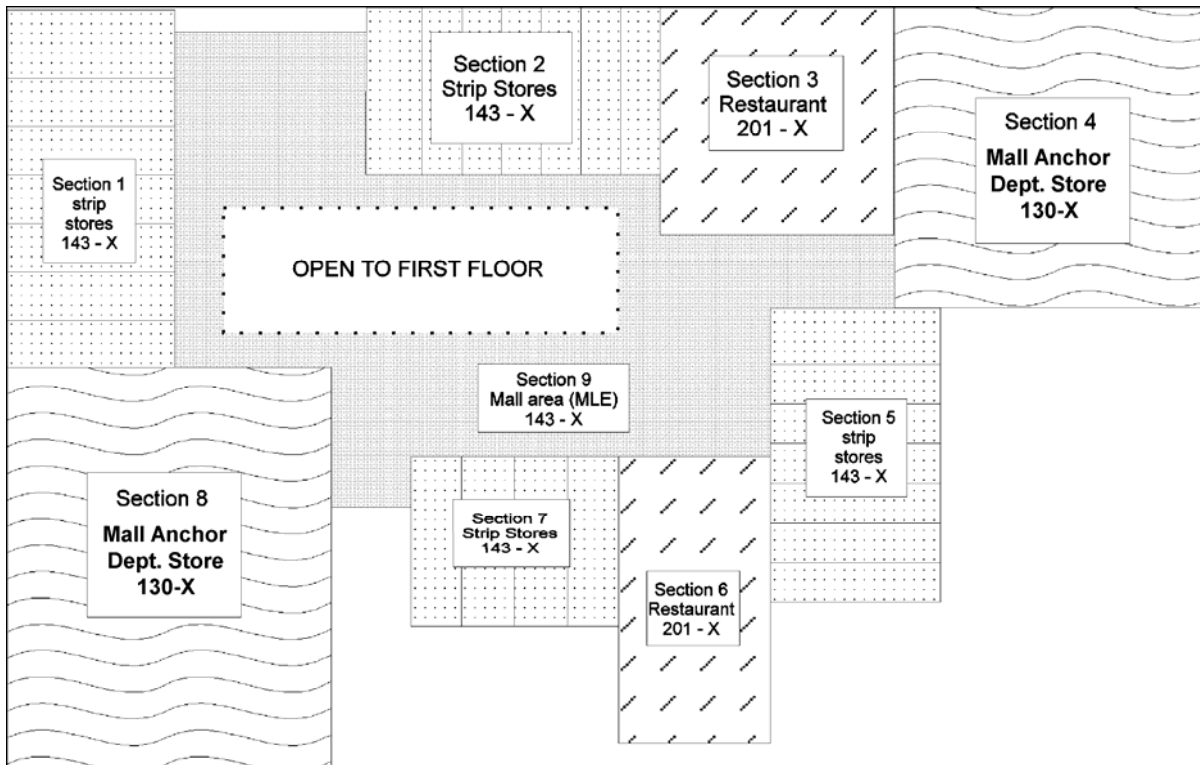

**CONVENIENCE MARKET OR MINI - MART CONVENIENCE MARKET
WITH SELF-SERVICE GAS**

A convenience market or mini-mart convenience market with self-service gas facilities has components typical of both a self-service gas station model and a convenience / mini-mart market model. These models have different depreciation rates. The following procedure should be used to ensure that the correct depreciation is applied to each component:

1. The convenience / mini-mart market building should be listed using the 113 - X or 119 - X model (Convenience Market or Mini-Mart Convenience Market).
2. The site improvements associated with the convenience / mini-mart market are defined as those improvements within 20 feet from the front of the building and all improvements to the sides and rear of the building. These should be listed using the 101 - X model (Commercial Yard Improvements). See drawing below. If mini-mart is located under the pump canopy, see number 4.
3. The gas pump canopy, pump islands, cashier's booth (if present), and all site improvements outside the 20-foot boundary should be listed using the 172 -X model (Self-Service Gas Station). See drawing below.
4. Mini-Mart Convenience Markets may be located underneath the pump canopy. If this is the case, list the mini-mart building using the 119 - X model and all other improvements using the 172 - X model.

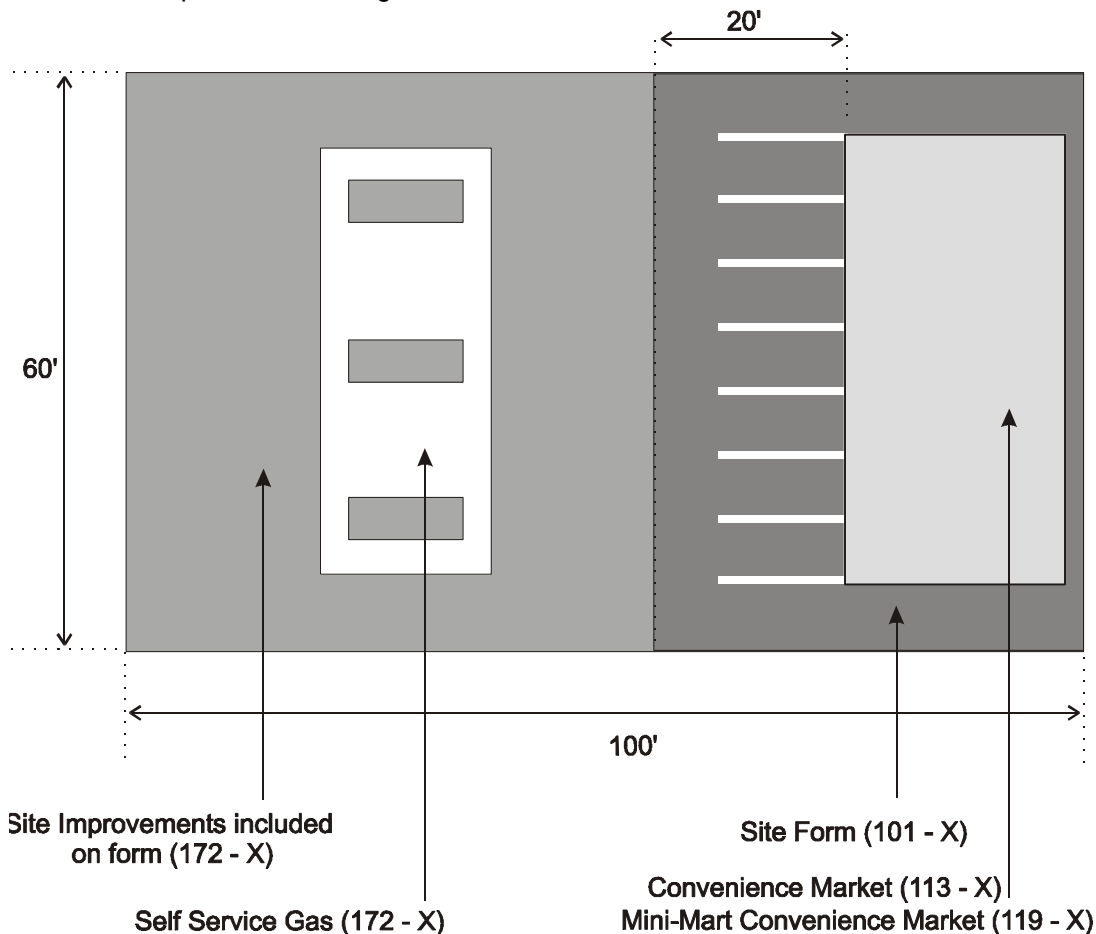

CLEAN ROOM LISTING PROCEDURE

A clean room is defined as: "A special purpose room that meets requirements for the absence of lint, dust or other particulate matter. In a clean room, the filter systems are high efficiency and the air exchange is one-directional laminar flow"¹. Laminar flow refers to the constant non-turbulent filtered air changes which, in a Class 10 clean room, may approach 600 air changes an hour.

There are two factors to consider when listing a building that contains a clean room. First, how to properly list the clean room itself. Secondly, what adjustments to the listing of the whole building may be necessary to account for the costs included in the clean room component.

Each clean room space is specially engineered, so costs can vary greatly. Three clean room components, KYC, KYD, and KYE, can be used. Enter the square footage of the clean room in the units field. Costs include all the lighting, electrical, plumbing, and **HVAC** required to support the clean room space plus the wall, ceiling, and floor finishes required for the clean room envelope.

Selection of the correct component is determined by the number of particles of a certain size that are allowed to be present in a cubic foot of air.

KYC - Class 100,000 to 10,000. This cost range represents cleaned space that has no more than 100,000 to 10,000 particles of 0.5 microns or larger per cubic foot of air.

KYD - Class 1,000 to 100. This cost range represents cleaned space that has no more than 1,000 of 0.5 microns or larger to 100 particles of 0.3 or larger per cubic foot of air.

KYE - Class 100 to 10. This cost range represents cleaned space that has no more than 100 particles no larger than 0.3 microns to 10 or fewer particles of 0.12 or less microns in a cubic foot of air.

To determine the adjustments to the listing of the whole building, the appraiser must first investigate whether the clean room was built as an integral part of the original construction of the building or was added some time after the building was complete. In either case, the entire shell building should be listed including the foundation, frame structure, exterior walls, roof structure and cover, and floor structure. If the clean room had been built as part of the original construction, the square footage of the clean room should be deducted from the following interior components: floor and ceiling cover, interior construction, plumbing, electric, and heating / cooling. As stated above, these costs are included in the clean room component. However, if the clean room was added after the improvement was completed, only the interior construction, floor, and ceiling cover components should be reduced by the square footage of the clean room. The plumbing, electric, and heating/cooling were originally engineered with sufficient capacity and subsequent cost to service the entire building.

As an alternate procedure, the appraiser can use actual contract costs if the costs exceed \$250,000. The actual costs can be added using the Special Construction component (**SCO**). Enter the total dollar cost of the clean room in the units field.

If the component SCO is used, the cost will **not** be automatically updated each year by the Construction Cost System. It will be the responsibility of the county assessor to trend the cost on an annual basis. This can be done by using Marshall & Swift's comparative cost indexes found in the Marshall Valuation Service Manual and developing a cost modifier that will trend the historical cost to current replacement cost. The following is an example of how to trend a historical cost.

¹ Kornelis Smit, ed., *Means Illustrated Construction Dictionary* (Kingston, Ma: R. S. Means Company, Inc., 1985), p. 102.

Actual Construction Cost X $\frac{\text{Cost index prevalent the July previous to the valuation year}}{\text{Cost index closest to the date of completion of construction}}$ = Current Replacement Cost

Actual Construction Cost (as provided by contractor or owner) = \$500,000

Cost Index prevalent the July previous to the valuation year = 1366.8

Date of Construction Cost Index = 1166.7

$$\$500,000 \times \frac{1366.8}{1166.7} = \text{Current Replacement Cost}$$

$$\$500,000 \times 1.172 = \text{Current Replacement Cost}$$

$$\$586,000 = \text{Current Replacement Cost}$$

The appraiser should then use this current cost to update the previous cost in the units field of component SCO. A number 9 should be entered in the [review field](#) of the improvement listing to indicate this trending needs to be done every year.

Please note: Clean rooms listed in the semiconductor industry are required by ARS 42-15066 to be valued and assessed as tangible personal property. Clean rooms used in any other industry are still subject to the determination of real vs. personal property. See the DOR Personal Property Manual for guidelines when determining real vs. personal property.

PERMANENT CROP LISTING PROCEDURE

The listing of permanent crops includes the following models and components:

MODELS	COMPONENTS
421-3 Vineyards	WGR Vineyards
431-3 Citrus Trees	WCI Citrus Trees
	WLT Lemon Trees
	WOT Orange Trees
	WOTM Orange Trees, Minneola
	WOTN Orange Trees, Navel
	WPG Pink Grapefruit Trees
	WTA Tangelo Trees
	WTT Tangerine Trees
441-3 Other Tree Crops	WAP Apple Trees
	WSF Stone Fruit Trees
442-3 Nut Trees	WNU Nut Trees
443-3 Pecan Trees	WNP Pecan Trees
444-3 Jojoba Plants	WJO Jojoba Plants
445-3 Date / Olive Trees	WDA Date Trees
	WOLV Olive Trees
446-3 Christmas Trees	WCH Christmas Trees



Use DOR form **#82367**. Enter the appropriate model on the baseline. The only other baseline entry needed will be to enter the year planted in the "Date Planted" field.

Choose the correct component/s and enter the number of acres planted for each component. For the same crop planted in different years, use a separate form and make each planting year a separate section.

These listings will not produce a cost until the crops reach the maturity dates found in Table C.1, page C.1 of the Agricultural Manual. A copy of that table is reproduced below.

Permanent Crops
Value at Maturity, Dates of Maturity

	Value Per Acre At Maturity	Maturity Date ¹ Year After Planting
Apples and Stone Fruit	\$100	Fourth Year
Christmas Trees	\$600	Third Year
Citrus	\$600	Fifth Year
Dates	\$100	Fifth Year
Grapes	\$100	Fourth Year
Jojoba	\$100	Eighth Year
Nuts	\$600	Eighth Year

¹Maturity date is January 1 of the year following the number of years listed above after the permanent crop was planted.

BASELINE FACTORS

In determining the replacement cost new (and the final value) of any building, the items listed on the baseline in the cost system are the items that drive the costs and therefore are the most important part of the system. Keep in mind that the appraiser must still select the proper components from each section on the form. Without the components being selected, the system will not produce a value. Although the listing of the improvements are generally used by the Arizona Construction Cost System to generate the cost approach to value, the actual listing should be thought of as a property characteristics file which needs to be as accurate as possible. As time and resources permit, the Property Tax Division may be looking at adding an income model and a commercial market model to the possible choices provided to the local assessor. These models will still use the property characteristics (cost) file for the characteristics needed to generate a value estimate utilizing the new models.

The model number is the first item required on the baseline. The model number is composed of two parts and each is equally important. The first three digits indicate the type of building being appraised with the first two digits indicating the original architectural design of the building. It is important that this be the original design of the building, not what it is currently being used as. The cost of replacing any building will be determined by this original construction type. On a few occasions, the building may have altered enough to warrant going away from the original design to a different model number, but this would be the exception rather than the rule. The first two digits indicate the general type of building (15 equates to an office building), while the third digit indicates a subgroup within the general group such as an office building with ground floor parking (152).

The fourth digit indicates the quality grade of the building. Determining the correct quality grade is just as important as the model number itself and is a very crucial step in the process. All buildings must be graded for quality of design, workmanship and materials as follows:

Below Average Quality

These buildings are generally constructed to meet the minimum building code. Little ornamentation and a lack of architectural design are apparent. The interior partitioning and finishes are minimal building code and of low quality.

Average Quality

These buildings are generally constructed to meet the standard code construction. Buildings in this group make up the largest portion of construction (approximately 50 percent or more). They are generally designed for maximum economic potential without the amenities found in higher quality construction. Ornamentation and architectural design are not elaborate. The interior partitioning and finishes are average building code construction.

Good Quality

Good quality buildings are designed for good appearance, comfort and convenience as well as some element of prestige. Higher quality ornamental treatment and interiors are evident. Primary elements and amenities of higher costs are better lighting and mechanical work. Good quality construction is similar to average quality construction with these exceptions: more and better material, more detail of design, higher mechanical and electrical costs, and better quality of workmanship is applied to all aspects of the building.

Excellent Quality

Excellent quality buildings are usually superior, prestige buildings with some expensive finishes and fixtures. These will show more ornamentation, special architectural design, and top quality workmanship and materials. However, for those most luxurious buildings that are built without regard for cost, the listed costs will not be high enough since each listed cost represents the average of costs within the quality range.

Determining Quality Grade:

The quality grade of any building is determined by three things: design, workmanship and materials.

The material portion is probably the easiest to identify because the material can readily be seen. The average building utilizes average material and will be material that is the most commonly used throughout the industry for the type of property. This material will be of sufficient quantity, thickness and quality to meet the standard building code and little more.

In residential construction, quality can be seen in different types of material being used. This is usually evident in the quantity and quality of the doors and windows used. Wood doors are generally more expensive than steel doors; solid core interior doors are more

expensive than hollow-core doors; casement windows are generally more expensive than double-hung; wood windows with a vinyl or steel covering are more expensive than the steel or aluminum framed windows; dual and triple pane windows with divided lights are more expensive than single pane. The material used in the exterior wall is important. Block, slumpstone, brick and stone are generally used in the higher grades of building. Another place that quality can be seen is in the kitchen cabinets. Lower quality homes will generally have cabinets made of particleboard for the fronts as well as the boxes and will be present in a minimum amount. Average homes will have cabinets made of particleboard boxes, but the face and doors will be made of hard wood. These cabinets will be of sufficient quantity to meet the needs of the home owner without being excessive. They will have few if any extras such as pullout shelving or lazy susans. Higher quality homes will have an abundance of all wood cabinets with several extras such as dovetail joints, extra pullout shelves, glass doors, etc. In the higher grade of homes, the cabinets may be custom made.

Other items that may be a key in determining the quality grade are the woodwork, painted softwood versus stained hardwood; floor covering, large area of tile or wood versus vinyl; better, thicker grade of carpeting; more built-in items such as china hutches, entertainment centers, and computer desks. The roof cover will generally change from asphalt shingles to wood shakes, tile, or slate as you move into the higher grades. The pitch of the roof may also increase.

The design is determined by the overall size and complexity of the building and can usually be determined by looking at the overall desirability of the building. As a rule the more corners in the exterior wall, the more expensive the building is to build and the better the quality. The quantity and placement of the doors and windows, the amount of ornamentation, the floor plan and overall layout of the building, the roof and roof cover, the more breaks in the roof line and better quality materials are all indicators that more design and planning have gone into the building.

Workmanship is the last item to consider in determining quality grade. Workmanship is not always as easy to recognize because it can be buried in the details of the building. Questions to ask are does the woodwork have mitered joints and do they close, is the tile laid straight, is every little detail perfect or does the workmanship appear to be less than ideal. Even with the best material, if the workmen do not take the time to do things correctly, the quality will suffer.

It is important to remember that quality is not just one or two items mentioned above. Quality is the combination of all of the above items and much more. All of these items must be looked at along with the whole building. The overall impression of the property will probably be a good indicator of the true quality grade of the building. One common error or trap that most appraisers fall into is allowing the condition of the building to influence their selection of the quality grade. If the building is in poor physical condition, the appraiser tends to grade the quality down. The same thing can happen if the building is better than average condition; the appraiser tends to grade the building higher. In your mind, you must separate the condition and grade of the building. Learn

to look past the condition and see the building as if it were new to help determine the grade. Condition is a matter of value and should be addressed in the depreciation section as additional physical deterioration.

In grading commercial buildings, the actual material used will change, but the items to look for design, material, and workmanship remain the same.

Finally, in the determination of the overall quality grade of any building, the market place is the only true and ultimate judge. If the market does not agree with the quality judgments you are making, it will be indicated in the sale price of the property. The sale price per square foot compared to the final value as determined (assuming everything else, land, etc. is correct) should be very close. If not, this is a good indicator that you are incorrectly grading the building. At this point you would need to go back and review the decision and thought processes involved and adjust them accordingly.

The rest of the items on the baseline are important as well, but they are much more mechanical in nature and therefore, not as subjective. The construction class indicator (CCI) is based on the type and amount of structural framing in the building. The perimeter is usually based on the measurement around the first floor of the building. In the case of multi-stories, it may be necessary to average the perimeter based on the perimeter of each floor. It is important that the perimeter measurement be made around the entire building back to the starting point so that the footprint of the building closes, even if the walls do not actually exist. The adjustment to the costs should and will be made in the exterior wall section of the components as the exact amount of existing wall can be entered as percentage of the total wall area or as the square footage of wall area.

For a more complete discussion of these items and for a discussion of the rest of the items on the baseline, see the Construction Cost Manual. You will also find the cost manual contains a fairly complete discussion of how the system functions along with models, components, procedures, descriptions, adjustments, and other information needed to understand and make the system perform as needed for each county. If further information is needed, contact the Construction Cost Support Team at the Property Tax Division, Arizona Department of Revenue.

RESIDENTIAL GRADING GUIDE

	010-0	010-1	010-2
Sq. Ft.	150 to 500	400 to 800	800 to 1200
No. of Rooms	1 - 3	2 - 5	3 - 6
Design & Shape	Square or rectangular	Square or rectangular	Rectangular or "L" shaped
Exterior Walls	Wood frame with composition board siding	Painted block or wood frame with inexpensive plywood siding	Painted block or wood frame with stucco, plywood, or composition clapboard
Doors	Minimum quality, inexpensive hardware	Minimum quality, inexpensive hardware	Economy type masonite with economy hardware
Windows	Wood - non-moveable	Fixed wood or sliders or double hung - few poor quality windows	Aluminum sliders, steel casement, one per room, small, inexpensive picture window
Roof	Flat, shed type or low pitch with little or no overhang, galvanized metal	Flat, shed type or low pitch with little or no overhang, rolled roofing	Flat or low pitch with some overhang, asphalt shingles, 2 x 4 rafters
Floors	Wood on piers or concrete slab	Wood on piers or concrete slab, minimum vinyl or no floor covering	Wood on piers or concrete slab, vinyl and inexpensive carpeting
Interior Walls	None	Minimum interior partitions with drywall, little or no closet space	Interior partitions with drywall, some closet space, low cost doors and trim
Electrical	Hanging lights, no outlets, drop cords	Minimum one light per room, minimum outlets and switches	Adequate lighting, outlets and switches
Kitchen	Minimum, pine shelves, small sink, small or no drain board	5 - 8 l.f. of pine shelves or metal cabinets	6- 10 l.f. of economy grade, particle board cabinets
Plumbing	0 to 3 fixtures, minimum quality, no water heater	1 to 3 fixture bath, minimum quality	3 fixture bath, economy grade

RESIDENTIAL GRADING GUIDE





	010-3	010-4	010-5
Sq. Ft.	900 to 2,200	1,500 to 3,000	2,400 to 4,000
No. of Rooms	4 - 8	6 - 9	7 - 11
Design & Shape	Rectangular or "L" shaped, some ornamentation on front of house	Rectangular or "L" shaped, custom front with some custom design features	Custom design - built to owners' specification
Exterior Walls	Block, slumblock or wood frame with some ornamentation on front of house	Block/stucco or wood frame with custom front elevation of brick, stone or other similar material	Block/stucco or wood frame with very elaborate front elevation of brick, stone or other similar material
Exterior Doors	Steel, fiberglass or wood front door, sliding glass door with medium grade hardware.	Custom single or double front doors with good quality hardware, French doors or good sliding glass doors rear of the house	Special entry, solid-core, oversized, hardwood, brass, gold plating, imported with special hardware
Windows	Aluminum sliders, picture window, well placed and adequate number, single or dual pane	Better grade aluminum sliders or wood with some custom design, dual pane/tinted or better	Good grade windows, usually casement, custom design, dual pane/tinted or better.
Roof	1-2' overhangs, 2x6 rafter or 2x4 trusses, asphalt, wood shingles or light weight concrete tile usually 4 or 5:12 pitch	2-3' overhangs, complex design, 2x6 rafters or trusses, 5 or 6:12 pitch, wood shingles, or tile	Wide overhangs, complex design, 2x6 rafters or trusses, 6 to 8:12 pitch, clay or concrete tile
Floors	Concrete slab or wood floor over foundation, average grade vinyl/carpet, small amount of tile	Concrete slab or wood floor over foundation, good grade carpet or hardwood, ceramic tile in kitchen & bath areas	Concrete slab or wood floor over foundation, good grade carpet or hardwood, ceramic or quarry tile in many areas
Interior Walls	Drywall, painted/textured walls & ceilings, adequate closet space, wood painted trim with hollow core wood or masonite doors	Drywall, painted/textured walls & ceilings, large closets, wood stained trim with hollow core wood doors, some wallpaper & paneling for decoration	Drywall or plaster walls & ceilings, special finishes, large closets with special linings, hardwood stained trim with solid core wood doors, some wallpaper & paneling for decoration
Electrical	Adequate outlets and fixtures, 2-220 volt outlets	Good fixtures, some ornamental, such as entry way & dining areas, several outlets including 220 volts outlets, may include special wiring & cabling for intercoms, stereos & TV systems	Good fixtures, special wall fixtures & lighting effects, custom switches & numerous outlets including 220 volts outlets, may include special wiring & cabling for intercoms, stereos & TV systems
Kitchen	Average grade cabinets with hardwood frame and doors, wood fronts with particleboard boxes, 15-25 l.f. of cabinets with Formica countertops, double sink & disposal	Good grade cabinets, wood fronts & boxes, 20-35 l.f. of cabinets with Formica or tile countertops, center islands & several built-in appliances	Custom cabinetry, hardwood paneled & carved doors, custom countertops and built-in appliances, 30 to 50 l.f. tile or inlaid countertops
Plumbing	1 to 3 bathrooms with average grade fixtures, fiberglass or tile showers & tub areas, adequate laundry hook-ups, master bath may contain 3 to 5 fixtures	2 to 5 bathrooms with good grade fixtures, tile showers & tub areas, laundry hook-ups, master bath may contain 5 to 7 fixtures including sunken or whirlpool tubs and oversized showers	Good grade fixtures, elaborate layouts, lots of ceramic tile, sunken, whirlpool tubs, custom glass doors and special features

RESIDENTIAL GRADING GUIDE

	010-6	010-7
Sq. Ft.	3,000 to 8,000	7,500 and up
No. of Rooms	10 - 15	15 and up
Design & Shape	Architecturally designed, built to maximize the site; elaborate floor, may contain separate quarters for domestic help and guests	Unique - designed and built with little or no regard to cost, may contain separate guest quarters & separate quarters for domestic help
Exterior Walls	Ornamental perimeter elevation, elaborate entryways, decorative stone cornice and archways	Ornamental perimeter elevation, elaborate entryways, decorative stone cornice and archways.
Exterior Doors	Special entry, solid-core hardwood, brass or gold plated, imported, special hardware	Special entry, solid-core hardwood, brass or gold plated, imported, special hardware
Windows	Custom wood or ornamental framing, special shapes, triple pane glass with true divided lights, usually casement type in large quantities, many may contain special glass such as beveled, leaded, or stained	Custom wood or ornamental framing, special shapes, triple pane glass with true divided lights, usually casement type in large quantities, many may contain special glass such as beveled, leaded, or stained
Roof	Large overhang, enclosed soffit, top quality roofing, ornamental roof vents, complex design with very high slopes, slate or other expensive roof covering	Large overhang, enclosed soffit, top quality roofing, ornamental roof vents, complex design with very high slopes, slate or other expensive roof covering
Floors	Top grade of carpet, extensive use of imported marble, tiles, brick, etc.	Top grade of carpet, extensive use of imported marble, tiles, brick, etc.
Interior Walls	Plaster, brick, stone, custom wall covering, custom, built-in hardwood accessories, custom paneling, hardwood doors & trim, top quality hardware, generous closet space, unusual and special features	Plaster, brick, stone, custom wall covering, custom, built-in hardwood accessories, custom paneling, hardwood doors & trim, top quality hardware, generous closet space, unusual and special features
Electrical	Excellent quality fixtures, ornamental with special effects, recessed and indirect lighting, custom quality, special wiring & cabling for intercom, stereos, & TV/computer systems	Excellent quality fixtures, ornamental with special effects, recessed and indirect lighting, custom quality, special wiring & cabling for intercom, stereos, & TV/computer systems
Kitchen	Elaborate layouts, good hardwood panels & carved doors, inlay & sculpture doors, built-in quality appliances, 40 to 100 l.f., tile or inlaid countertops	Unique design, custom hardwood panels & carved doors, inlay & sculpture doors, built-in quality appliances, 80 to 200 l.f., tile or inlaid countertops
Plumbing	Excellent grade fixtures, custom tile or marble, elaborate light, mirrors, glass, many special features, spas, steam rooms, oversized & custom made showers and sunken tubs	Excellent grade fixtures, custom tile or marble, elaborate light, mirrors, glass, many special features, spas, steam rooms, oversized & custom made showers and sunken tubs

The information below may assist you in determining a quick relationship in overall cost levels between related models. Not all models are listed. There will be a certain amount of overlap between classes and cost ranges in certain models. These order-of-magnitude lists are presented as a rough guide at best and are presented as a teaching aid only.

MODEL FLOW CHART

Category	Outbuilding Mostly Unfinished  Some Finished Floors, Interior Buildout, Low-cost Mechanicals  Greater Partition Density Better Lighting & Plumbing Increased Personnel Density  Fully Finished Buildout Upgraded Mechanicals  High-Cost Buildout, Best Finishes, High Partition Density, Best Mechanicals
Farm	Shelters - Sheds - Poultry - Barns - Hog - Dairy - Stables
Industrial	Farm Implement - Lt. Comm'l Equipment Shops - Garages - Hangars - Maintenance Repair Garages - Municipal Garages - Showrooms Farm Ut. - Lt. Comm'l Ut. Bldgs. - Warehouse - Distribution - Light Industrial - Flex Buildings - Lofts - Research & Engineering - Laboratories
Commercial	Shed Offices - Relocatable Offices - Office Apartments - Office Buildings - Administrative Offices - Banks
Medical	Veterinary Hospitals - Dispensaries - Medical Offices - Clinics - Hospitals - Surgery Centers
Public	Volunteer Fire Stations - Staffed Stations - Police Stations - Libraries - Community Services - Governmental - Jails
Retail	Warehouse Stores - Warehouse Showroom - Discount Stores - Retail Stores - Department Stores Neighborhood - Community - Discount - Regional Shopping Centers Roadside Stands - Food Warehouse Stores - Markets - Convenience Stores - Specialty Minimarts
Food Services	Snacks Bars - Cafeterias - Bars - Lounges - Truckstops - Restaurants, Table Service - Fast Food
Assembly	Farm Arenas - Armories - Cinemas - Auditoriums - Churches - Live-Stage Theaters Club Houses - Country Clubs - Fraternal - Visitors' Centers - Convention Centers - Museums
Recreational	Tennis Courts - Arcades - Health Clubs - Racquetball/Handball - Bowling - Fitness Centers - Casinos
Educational	Field Houses - Shower Buildings - Restrooms - Gymnasiums - Physical Education - Natatoriums - Multipurpose - Commons Manual Arts - Relocatable - General Classrooms - Lecture - Labs - Science - Theater Fine Arts Day Care - Technical Trade Schools - Middle - High - Elementary Schools - Colleges
Residential	Farm Labors - Rooming Houses - Fraternity Houses - Rectories Guest Cottages - Motels - Inns - Lodges - City Clubs - Hotels Multiple Residences - Dormitories - High-rise Apartments Senior Multiples - Assisted Living - Elderly Apartments - Group Care Homes - Convalescent Hospitals Seasonal Cottages - Cabins - Townhouses - Single Family - High-value Residences

PROCEDURES FOR ENTERING MOBILE HOMES, MOBILE HOME ADDITIONS, AND MOBILE HOME YARD IMPROVEMENTS INTO THE CONSTRUCTION COST SYSTEM USING THE FACTORY LIST PRICE

The following models, procedures and component have been added to the Construction Cost System and are available for use at the discretion of the Assessor. The procedures described allow all information concerning mobile homes to be captured in the same manner (in the cost file) as well as allowing the appraiser more flexibility in determining the final value for the mobile home. The models may be used to capture data on mobile homes and improvements currently taxed on the personal property roll (in the same manner as an unaffixed mobile home) in order to allow the costs to automatically update annually from the Construction Cost System and be transferred to the personal property tax roll. Existing mobile home models 080-x, Mobile Home Room Addition, and 081-x, Mobile Home Yard Improvements, may be used as part of these procedures.

ADDED MODELS

084-x Mobile Home – Not Affixed
085-x Travel Trailer – Not Affixed
086-x Park Model – Not Affixed
087-x Office – Not Affixed

ADDED COMPONENT

MOHU Mobile Home/Office – Not Affixed (Dollar Amount)
Restrictions: Models 084 through 087 only

This Component is used for mobile homes or mobile offices that are not permanently affixed. Enter the suggested retail selling price of the mobile home or mobile home office in the number of units field.

Note 1. For the purposes of this document, the term mobile home will also include travel trailers, park models, and mobile offices.

Note 2. The listing procedure described below uses the term “IPR”. This is for cost model convenience only.

Note 3. Programming changes may be required for non-client counties to use these procedures.

Basic Procedure

Complete a detailed baseline including perimeter, square footage, and average story height. Use the “number of stories” field to identify a single, double, or triple wide mobile home. Quality indicators 1 to 7 are now available for all of the mobile home models 083 through 087. Use of an indicator other than 3 will not change the suggested retail price but may be used to capture information on mobile home quality. You may also capture any physical condition adjustment (up or down) and obsolescence in the appropriate fields. These adjustments will be used in calculating the final value of the mobile home.

If the heating / cooling components of the mobile home are placed on the 081 – x (Mobile Home Yard Improvement) model; the perimeter, square footage, and average story height of the mobile home should be entered on the baseline. The 083 through 087 models should *only* be used for listing the suggested retail-selling price of the mobile home. All other components should be listed through the use of the 080 (Mobile Home Addition) and 081 (Mobile Home Yard Improvements) models.

Note: All improvements listed under the 080-x and 081-x model numbers will have values calculated using the same depreciation factors as mobile homes. This is appropriate for improvements connected to mobile homes since they tend to take on the same life (depreciation) as the main improvement. If you do not want the improvement value calculated using the mobile home depreciation factors, list it using the appropriate model number instead.

MOBILE HOMES AND IMPROVEMENTS ON THE PERSONAL PROPERTY ROLL

For mobile homes and improvements on the personal property roll, the first step in the procedure is to assign a parcel number to the improvements. One option is assigning special books and maps based on location, for example: a separate book-map-number to easily identify parks. Another option is to convert the personal property taxpayer number into a parcel number. Book 700 may be used. Simply prefix a 7 to the six-digit taxpayer number. Taxpayer number 1234567 becomes 712-34-567. The personal property location number becomes the split letter. For example, 1234567-01 becomes 712-34-567-A, 1234567-02 becomes 712-34-567 B and so on. The check digit will be calculated automatically. Book numbers other than 700 may be used if 700 is an active book in your county.

After converting the taxpayer number or assigning a parcel number to the personal property improvements, perform an IPR parcel create in PT-50. Use the legal description fields to record the physical location parcel number and Situs of the improvements plus the model, year made, and serial number of the mobile home. The mobile home park name may also be entered in the Situs field. This will permit identification through the X-REF screen.

Next, enter the cost listings in PC01 (Current Year). All improvements on the parcel must be listed using the appropriate models. List the mobile home as improvement 1. A mobile home room addition, if present, should be improvement 2. The mobile home yard improvements should be last on the parcel listings. Mark the IPR field of all the improvements.

For personal property mobile homes and improvements, update the location parcel number in UP01 with the new number. The old location parcel number may be transferred to the property location field.

AFFIXED MOBILE HOMES

The procedure for entering affixed mobile homes has not changed but the system has been changed to allow the appraiser to enter all baseline information including grade (1 through 7), perimeter, square footage of the unit, number of stories (used to capture the type of mobile home: 1 = single wide, 2 = double wide, and 3 = triple wide), physical condition, obsolescence, and modernization.

The grade will not currently affect the final value. It may become important later if a new valuation procedure is developed. The physical condition, modernization, an obsolescence factors will affect the final value of the mobile home.

This will allow more flexibility in determining the final value of all mobile homes.

Under these new procedures, the value of all mobile homes will be calculated using the manufacturer list price less depreciation from the mobile home depreciation tables published annually in the Personal Property and Construction Cost Manuals. The assessor will be able to adjust the value of the individual mobile home by applying the needed adjustments in the baseline. For mobile homes that are not affixed, the value will be generated using the cost system, and then transferred to the personal property roll for billing purposes.

If the mobile home is listed on the cost file and the UP01 system, the new value generated by the cost file will be used for billing purposes. If the mobile home is not currently on the cost file but is on the UP01 system, the value generated by the UP01 system will be the value used.

CAR AND STOP ELEVATOR LISTING PROCEDURE

There are two methods for listing elevators: the square foot and the car and stop method. The square foot method uses the component TA and the total square footage of the building. It is used for elevators in buildings where the square footage is in direct relationship to the number of people occupying the structure. Typically, offices, hotels, hospitals, high-rise apartments etc. are included in this category.

Marshall & Swift limits TA's use to specific categories of models. If the Cost System will not accept the TA component for a particular model: the car and stop components and procedure must be used.

1. See **Volume 1, Section 3, Elevators (type 19)** for a list of available car and stop components. Use the charts on pages 69 and 70 for ranking information.
2. Determine the different types of elevators in a building.
3. Count the number of elevator shafts for each type of elevator in the building. The number of shafts is entered in the number of units field of the listing form and mainframe component screen.
4. Count the number of stops each type of elevator makes. Include the first floor served in the stop count. For example, an elevator in a 2-story building would have 2 stops. The number of stops is entered in the misc. value field of the mainframe component screen. Exclude any bypass floors. Bypass floors are where the elevator shaft passes through the floor but the elevator was designed not to service that floor. There will be no access doors. Typical examples include penthouse elevators and express elevators in extremely tall buildings where a bank of elevators may skip a number of floors before stopping.
5. Use component **TR** for bypassed floors. Enter the number of bypassed floors in the number of units field. Story height should be considered when determining a rank.

ARIZONA DEPARTMENT OF REVENUE CONSTRUCTION COST SYSTEM SQUARE FOOT METHOD

The Department's Construction Cost System is a Segregated (a component system) Cost System. Marshall & Swift designed it primarily for use on large, complex buildings that require a great deal of component detail for an accurate cost value. Because of this, the system is more sophisticated than needed for most residential and commercial structures. This has resulted in a steep learning curve for new appraisers and extended time at the property to gather data and fill out listing forms. Back at the office, this means more work and more chance for input error by data entry personnel. In response to these issues, the Cost System has added a square foot method based on Marshall & Swift's Residential and Commercial Square Foot Calculator Programs. This method is an enhancement, not a replacement to the present segregated method. The segregated method remains available and unchanged except for the addition of a new field on the baseline labeled Grade. The square foot method is available for data entry into tax years 2005 and later.

The screenshot displays the 'PROPERTY INTERACTIVE INTERFACE CONSTRUCTION COST MODEL' window. The interface includes a menu bar (File, Edit, View, Tools, Session, Options, Help) and a toolbar with various icons. The main data area is as follows:

Q C WHAT IF		PROPERTY INTERACTIVE INTERFACE		PANEL : MPC2101	
BASE FACTORS		CONSTRUCTION COST MODEL		DATE : 09/16/2003	
IMPROVEMENT :	08 000 00 000	0 0000 00	COST-YEAR	TAX-YEAR	
MARKET ADJUSTMENT	.82	SQ FT(Y\N) Y	2005	2005	FUTURE-YEAR-1
BASE MODEL	GRADE	CLASS	DESCRIPTION	MARKET-SUB	
0103	A	D	SINGLE FAMILY DWELLING	0000	
GROUND FLOOR		TOTAL FLOOR	NUMBER OF	AVG. STORY	
PERIM	AREA	AREA	STORIES	HEIGHT	
00120	0001500	0001500	01.0	08	
CONSTRUCTION YEAR		PARTIAL COMPLETE	PERCENT OWNERSHIP		
1995		00	1.0000		
OBsolescence		MODERNIZATION	PHYSICAL CONDITION		
00		1. 00	1.00		
COST MARKET	REPLACEMENT	LOC REPLACEMENT	ASSESSABLE		
FULL CASH VALUE	FULL CASH VALUE	FULL CASH VALUE	FULL CASH VALUE		
0	77191	75647	58309		
PF3=EXIT	PF4=MAIN MENU	PF5=COMPONENTS	PF6=SAVE IMPROVEMENT	PF12=PRINT	
4B		:00.1	05/39		
Connected to host 10.11.6.2 (TCP20018)			Page001	NUM	7:45 AM

When the appraiser or data entry personnel brings up the baseline data entry screen, they will see two new fields. In the first field (SF: N/Y), the appraiser will indicate whether they elect to use the square foot method. The default is N for No. Changing the N to Y will cause the system to automatically enter the correct square foot component on the component screen. This will be discussed in greater detail below

To the right of the four-digit model/quality indicator, a new field labeled Grade has been added. This field was added to further refine the model quality indicator. After the appraiser selects an overall quality indicator, they will also enter an F (fair), A (average) or G (good) in this field. The default entry is A (average).

The appraiser's selection of a F (fair) or G (good) grade will change the default ranking of the components up or down according to the following table.

<u>Overall Quality Indicator</u>	<u>Component Cost Rank</u>		
	<u>Fair</u>	<u>Average</u>	<u>Good</u>
0 and 1	0.3	0.5	0.7
2	0.7	1.0	1.5
3 and 9	1.5	2.0	2.5
4	2.5	3.0	3.3
5	3.3	3.5	3.7
6	3.7	4.0	4.3
7	4.3	4.5	4.9

Note: The maximum cost ranking has been increased to 4.9 from the previous 4.5.

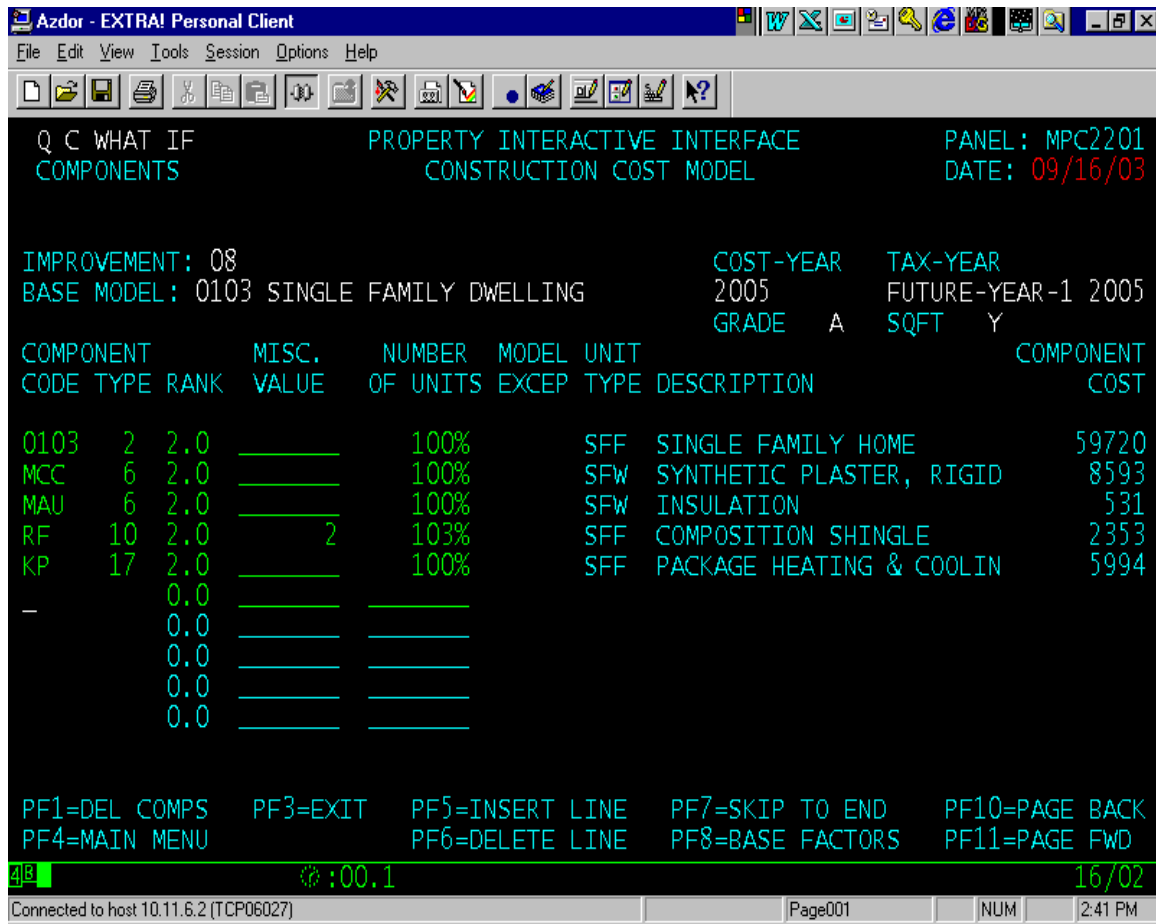

The procedure to determine the correct grade of an improvement will be discussed in the listing procedure section.

When the appraiser selects the square foot method and moves to the Component screen, the first line will contain the appropriate component (square foot cost) for the model listed on the Base Factor screen.

The appraiser will need to add additional components depending on the model chosen. The following list identifies what components are needed for each model grouping.

Residential

Exterior walls including wall ornamentation and bond beam if applicable.
 Roof cover
 Built-in items over the base. Base for R-2 and below equals garbage disposal, exhaust fans, TV outlets. On an R-3, a dishwasher is added and, on higher quality indicators (4 and above), a built-in range, oven and microwave.
 Heating and cooling
 Fire protection
 Elevators
 Fireplaces
 Porches and patios
 Balconies
 Basement
 Garages and carports
 All site improvements

Commercial

(Includes Model 375x)

Roof structure (needed only if the span between the supporting columns is greater than 40 feet)**
 Exterior walls including parapet, bond beam, insulation, wall ornamentation and storefront
 Heating and cooling
 Elevators
 Miscellaneous built-ins
 Balconies
 Basement
 Fire protection
 All site improvements

The following commercial square foot components do not include the cost of built-in coolers. The cost can be added by using the new component HSFC, square foot built-in coolers. Enter HSFC with the total square footage of the improvement to add cooler cost. HSFC should only be used in conjunction with the following square foot components.

112X	Supermarket
113X	Convenience Market
119X	Mini-Mart Convenience Store
120X	Drugstore
201X	Full Service Restaurant
202X	Fast Food Restaurant
203X	Cocktail Lounge
204X	Bar/Tavern
205X	Truck Stop

Warehouse

Roof structure (needed only if the span between the supporting columns is greater than 40 feet)**

Exterior walls including parapet, bond beam, insulation, wall ornamentation and storefront

Heating and cooling

Interior finish as before

Use HA (151-x) for office interior

Use HA (111-x) for retail interior

Add floor covering

Add ceiling finish

Add heating and cooling – office/retail area

Add heating and cooling – warehouse

Electrical (LA) office/retail space

Plumbing (IB-per fixture) 151-x override for office area

Plumbing (IB-per fixture) for the warehouse area

Dock-high floors

Shipping and loading docks

Elevators

Miscellaneous built-ins

Balconies

Basement

Fire protection

All site improvements

Cold Storage Warehouses

Same as warehouses except grade the improvement by the following criteria:

Quality indicator 3 – cooler and chill rooms only

(32° and over)

Quality indicator 4 – chilled and freezer rooms

(-15° to 32°)

Quality indicator 5 – chilled, freezer and sharp freeze

rooms (-15° and below)

Agricultural

Exterior walls including parapet, bond beam, insulation, wall ornamentation and storefront

Heating and cooling

Miscellaneous built-ins

Basement

Fire protection

All site improvements

**Roof structure: In improvements that have clear, long spans (over 40 feet), it will be necessary to add for trusses and girders. These components are typically QW – Glued Laminated Girders, QAB – Longspan Girders, QU – Steel Trusses, or QV – Timber Trusses. All these components are add items used in conjunction with the existing square foot costs. No other roof components are needed.

Note: Industrial Flex Buildings (model 375x) should be treated as commercial buildings. Use the amount of interior finish and the following chart as a grading guide.

Quality 3 Fair	19% and under
Quality 3 Average	20% to 40% interior finish
Quality 3 Good	41% and over

If the interior finish is over 60%, a different model is probably needed.

In order to simplify the listing procedures and to ensure uniformity, the following percentages should be used for heating and cooling.

Quality 3 Fair	10%
Quality 3 Average	30%
Quality 3 Good	45%

The square foot system will not work for some improvements such as complex industrial properties, high-end improvements or very poor quality improvements. It will not be accurate enough to meet your needs. Continue to use the segregated system on those improvements. Simply leave the default N for no when you enter the baseline screen and enter the usual components for the segregated system.

Changing a Segregated Listing to Square Foot

When you add a square foot listing, the system automatically inserts the appropriate square foot component as the first component of the listing. However, the appraiser or data entry person must manually add the square foot component when changing a existing segregated listing into a square foot listing. On the following pages are a complete listing of all available square foot components. The quickest and safest method of converting a segregated listing is as follows:

1. Pick appropriate square foot form: residential, commercial or warehouse.
2. Bring up existing segregated listing on the mainframe under change. Do not delete existing segregated listing. Deleting existing listing will also delete improvement history.
3. Fill out the form's baseline from mainframe listing and then press F5 to move to the component screen.
4. Enter appropriate square foot component on form from list in training manual.
5. Fill out the rest of form with components on mainframe listing. Use the component list in training manual as a guide.
6. After the square foot form is complete, press F8 to go back to baseline. Change N to Y and then press F5 to go to the component screen.
7. Press F1 twice to delete all components.
8. Enter square foot component and all other components from square foot form.

Press F8 to go back to baseline and F6 to save changes

Square Foot Components

0101 thru 6 and 9, Single Family Home
0122 thru 6 and 9, "A" Frame Home
0132 thru 6 and 9, Log Home
0142 thru 6 and 9, Dome Home
0152 thru 6 and 9, Rammed Earth Home
0162 thru 6 and 9, Earth Sheltered Home
0172 thru 6 and 9, Envelope Home
0182 thru 6 and 9, Specialty Home
0192 thru 6 and 9, Hillside Home
0201 thru 6 and 9 Single Family Residence, Multi-Story
0281 thru 6 and 9, Factory/Site Built Home
0321 thru 5 and 9, Duplex
0332 thru 5 and 9, Triplex 0342 thru 5 and 9, Fourplex
035X Apartment (3 or less stories)
036X Apartment (4 or more stories)
037X Retirement Apartments
038X Assisted Living Apartments
041X Hotel
042X Dormitory
043X Hotel, Full Service
044X Hotel, Limited Service
051X Motel
060X Day Care Center
0702 thru 6 and 9, Condo–Townhouse (Entire Bldg)
0712 thru 6 and 9, Condo–Townhouse (Inside Unit)
0722 thru 6 and 9, Condo–Townhouse (End Unit)
102X Laundry Building
103X Rest Room Building
104X Depot
105X Guardhouse
110X Laundromat–Dry Cleaning Plant
111X Retail Store
112X Supermarket
113X Convenience Market
114X Strip Store
115X Vehicle Sales
116X Barber–Beauty Shop
117X Warehouse Food Store
118X Warehouse Showroom Store
119X Mini-Mart Convenience Market
120X Drugstore
130X Mall Anchor Department Store
131X Department Store
132X Discount Store
133X Warehouse Discount Store
134X Mega-Warehouse Discount Store
141X Neighborhood Shopping Center
142X Community Shopping Center
143X Regional Shopping Center
144X Neighborhood Shopping Center-Shell Only
145X Community Shopping Center-Shell Only
156X Regional Shopping Center-Shell Only
151X Business Office
152X Business Office, First Floor Parking

153X Business Office-Shell Only
154X Business Office, 1st Floor Parking-Shell Only
161X Central Bank
162X Branch Bank
176X Mini-Lube Garage
178X Automotive Repair
179X Auto Parts and Service
201X Restaurant, Full Service
202X Restaurant, Fast Food
203X Cocktail Lounge
204X Bar-Tavern
205X Truck Stop
210X Medical-Dental Clinic, First Floor Parking
211X Medical-Dental Clinic
212X Veterinary Clinic
213X Hospital
214X Nursing Home
215X Emergency Medical Dispensary
216X Surgical Center
220X Mortuary
251X Theater, Walk-in
271X Lodge
272X Clubhouse
273X Health Club
274X Handball-Racquetball Club
275X City Club-"Y"
276X Bowling Alley
277X Country Club
278X Skating Rink
291X Parking Garage, Above Grade
292X Parking Garage, Below Grade
370X Warehouse, Transit
371X Warehouse, Storage
372X Warehouse, Distribution
373X Mini-Storage
374X "T" Hangar, Aircraft
375X Industrial Flex Building
376X Aircraft Storage Hangar
377X Warehouse, Cold Storage
379X Mega-Warehouse
380X Lumber Storage, Horizontal
381X Equipment Maintenance-Storage
382X Industrial Manufacturing
384X Industrial Manufacturing-Medium
385X Industrial Engineering
386X Industrial Light Manufacturing

387X Industrial Heavy Manufacturing
388X Industrial Building-Shell Only
400X Labor Dormitory–Bunk House
401X Dairy
405X Poultry House
408X Hog Finishing–Farrowing Barn
412X Cotton Gin
450X Produce Packing Barn
451X Barn
452X Agricultural Utility Building
453X Horse Arena
454X Hay Shed–Livestock Shelter
455X Horse Stable
900X Post Office
901X Courthouse
902X Library
903X Church
904X Fire Station
905X Prison / Correctional Facility
906X Elementary School (All Buildings)
907X Secondary School (All Buildings)

FINE TUNING QUALITY

Part of the appraisal process includes the estimate of the overall “quality indicator” to improvements. At times, improvements do not fit into a particular overall “quality indicator” category, so an appraiser may use the “grade” field to accommodate improvements that do not have a perfect fit. By adjusting the overall “quality indicator” with the “grade” an appraiser may estimate improvement cost.

For example, an appraiser has the flexibility to use overall “quality indicator” 3 and a “grade” of “good” (2.5) to add cost for the interior component upgrades. Conversely, an appraiser has the flexibility to use overall “quality indicator” 4 and a “grade” of “fair” (2.5) to adjust cost downward for minimal interior components. Typically, the quality of exterior components will give a good indication of interior components and have a “grade” of “average”, but sometimes an interior inspection will reveal the need for an adjustment to the “grade” of the improvement. The cost system provides the “grade” as an adjuster to the overall “quality indicator” to fine-tune the estimate of cost.

Appraisers may have a tendency to use “grade” to adjust for new components that have compatibility with the overall “quality indicator” instead of adjusting depreciation. Appraisers must remember “grade” and overall “quality indicator” relates to quality of components and quality of workmanship, and depreciation relates to condition of components. Appraisers must address quality and condition as two separate issues when estimating cost of improvements. The cost system provides a way to address quality and condition separately.

A house with “quality indicator” 3 exterior cost components sometimes has “quality indicator” 4 interior cost components. The house could have 1800 square feet, a rectangular shape, and wood frame construction, stucco siding, wood front door with medium grade hardware, adequate number of dual pane windows, a roof with a 1.5 foot overhang and light concrete tile. The exterior cost components point to an overall “quality indicator” 3. An interior inspection reveals ceramic tile floors in the kitchen, the living room, dining room and bathrooms. The bedrooms and hallway have a good grade carpet with a thick pad underneath.

Bathrooms and kitchen have cabinet boxes and cabinet fronts of maple. The bathrooms and kitchen have good quality Formica countertops. The interior of the house has many "quality indicator" 4 cost components installed with good workmanship. To capture the cost of the atypical interior components, the appraiser can call the house an overall "quality indicator" 3 and a "grade" of "good" (2.5) to add cost for the interior components. This situation occurs more frequently in older homes with renovation of the kitchen and bathrooms.

A house that has a preponderance of "quality indicator" 4 exterior cost components may have many "quality indicator" 3 interior cost components. The "quality indicator" 4 house may have 2000 square feet, a rectangular shape except for a bay window in the master bedroom and a bay window in the informal dining area. The master bedroom and the living room have French doors to the back yard. A large 12' high covered double front door entry with good hardware and 4' high stone veneer siding along the front of the house gives the house curb appeal.

The other sides of the house have stucco with dual paned tinted windows. The roof has a tile covering with a 3 foot overhang. The exterior of the house points to a "quality indicator" 4. Once inside you find walls with low grade stock baseboards, painted trim around the doors, and no trim around the windows. The bathrooms and kitchen have a vinyl floor covering and the rest of the house has low-grade carpet. The kitchen and bathrooms have cabinet fronts of an average grade of white washed oak and particleboard boxes.

The master bath does have a whirlpool tub and an oversized shower. The other two bathrooms have very average grade fixtures. The interior components of the house have an overall lesser quality than the exterior components. In this case an appraiser could call the house an overall "quality indicator" 4 and a "grade" of "fair" (2.5) to adjust cost downward for minimal interior components. It seems newer homes have the tendency to fall into this category, as some buyers want quality cost components and design features on the exterior with the hopes of upgrading the interior cost components in the future.

An appraiser can use this method to find balance between all the cost components in an improvement. The examples show how to fine tune cost estimates between "quality indicator" 3 and "quality indicator" 4, but the same process has application in any scenario that requires a cost estimate between "quality indicators" using the square foot system. A square foot system to determine cost lends itself well to mass appraisal. An appraiser will list far fewer components, so productivity increases while chance for error decreases. The square foot system and the segregated system generate very similar costs.

Many times appraisers will assign a "quality indicator" and "grade" from an exterior inspection. The cost system gives the appraiser flexibility to fine-tune the cost estimate using "grade" as an adjuster. We do not cover the entire "quality indicator" spectrum in this manual, but the following process has application to the entire spectrum of "quality indicators." For the sake of brevity, we will look at residences that fall between "quality indicator" 3 (fair grade) and "quality indicator" 4 (good grade) to demonstrate ways to select an appropriate "grade" to adjust cost. Appraisers will recognize distinct differences between "quality indicators."

“Quality Indicator” 3



“Quality indicator” 4



“Quality indicator” 3



“Quality indicator” 4



“Quality indicator” 3



“Quality indicator” 4



“Quality indicator” 3 design



“Quality indicator” 4 design



Frequently, homes have a blend of “quality indicator” components and design.



The presence of an Arcadia door or a French door helps decide the appropriate “quality indicator.” The quality of the front door can give a good indication of interior quality. The following pictures contrast the quality of door an appraiser would expect to see on a “quality indicator” 3 house with the quality of door an appraiser would expect to see on a “quality indicator” 4 house.

“Quality indicator” 3 front door.



“Quality indicator” 4 front door.

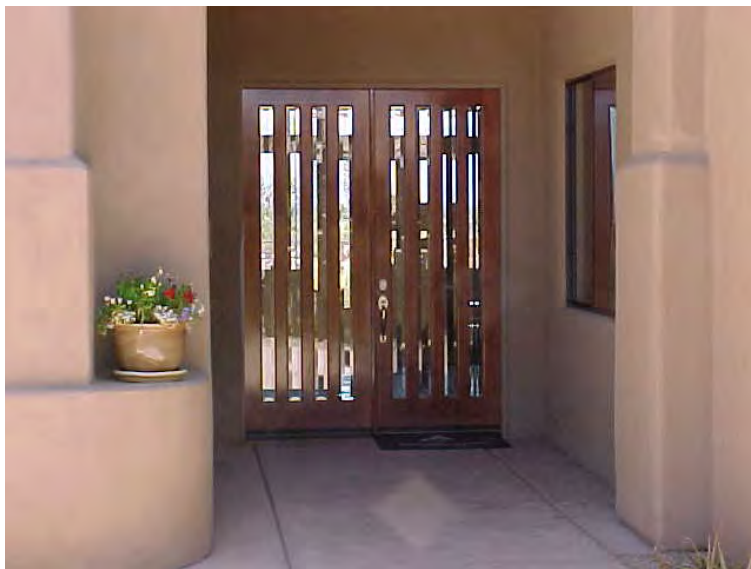

“Quality indicator” 4 front door.



“Quality indicator” 3 front door.



“Quality indicator” 4 front door.



Windows can help delineate “quality indicator.” These windows appraisers associate with “quality indicator” 3, “grade” good or better.



Windows can help delineate “quality indicator.” These windows appraisers associate with “quality indicator” 3, “grade” good or better.



These windows and skylights appraisers associate with “quality indicator” 3 “grade” good or better.



Greater pitch of a roof and complexity of roof design add cost to a home and need consideration to determine “quality indicator.” Usually, an appraiser will find that roof pitch and roof design correlate with “quality indicator.” The level of scuppers gives an indication of wall height and parapet height. Both wall height and parapet height contributes to cost. This page and the subsequent seven pages have pictures of roofs that exemplify different design and pitch. Also, you can see scuppers on several of the houses that have the Santa Fe architectural style.

Gable roof, simple design.



Flat roof with parapet, simple design.



Flat roof with parapet, complex design.



Flat roof with parapet, complex design.



Gable roof, L-shape design.



Hip roof, L-shape design.



Shed roof, simple design.



Hip roof, L-shape design.



Scuppers.



Scupper with downspout.



Hip roof, steep pitch.



Gable roof, steep pitch.



2 X 4 construction with 8 foot wall height.



2 X 6 construction and enclosed soffit.



Open soffit with minimal overhang.



Open soffit with minimal overhang.



Not just one component will determine “quality indicator” and “grade”, but the appraiser must decide the overall “quality indicator” and “grade” from all the components. Consistency by the individual appraiser will enhance uniformity. Again, most of the time an appraiser will not have any difficulty sorting through interior components on the way to determining an overall “quality indicator” and “grade.” Occasionally the lines blur between “quality indicators”, and with the cost system you can assign a “fair grade” or a “good grade” to estimate cost. When evaluating exterior components with interior components, consistency by the appraiser and among appraisers will enhance uniformity.

Appraisers do not always have the luxury of interior inspections to help estimate “quality indicator” and “grade.” An interior inspection in tandem with the exterior inspection makes the assignment of “quality indicator” and “grade” for the improvement much easier, and the confidence level in the appraisal rises. Again, for the sake of brevity, we will examine the difference between “quality indicator” 3 interiors and “quality indicator” 4 interiors. Remember that the principles discussed will apply to all “quality indicator” and “grade” determination decisions.

Consumers place a high priority on the kitchen and the bathrooms. The components that make up the kitchen and the bathrooms account for a lot of cost in a home. Generally, an appraiser can determine “quality indicator” and “grade” by the components and quality of workmanship found in a kitchen and the bathrooms. The components to consider include tile, granite, marble, Corian, Avanza, Silstone, vinyl, hard woods, Formica, veneer covered particleboard, fixtures and appliances.

The amount and combination of different components could point to a “quality indicator” or a “grade” within a “quality indicator.” On the following three pages you will see pictures of “quality indicator” 3 kitchens and bathrooms, and “quality indicator” 4 kitchens and bathrooms.

“Quality indicator” 3 kitchen.



“Quality indicator” 4 kitchen.



“Quality indicator” 3 kitchen.



“Quality indicator” 4 kitchen.



“Quality indicator” 4 bathroom.



“Quality indicator” 3 bathroom.



“Quality indicator” 4 bathroom.

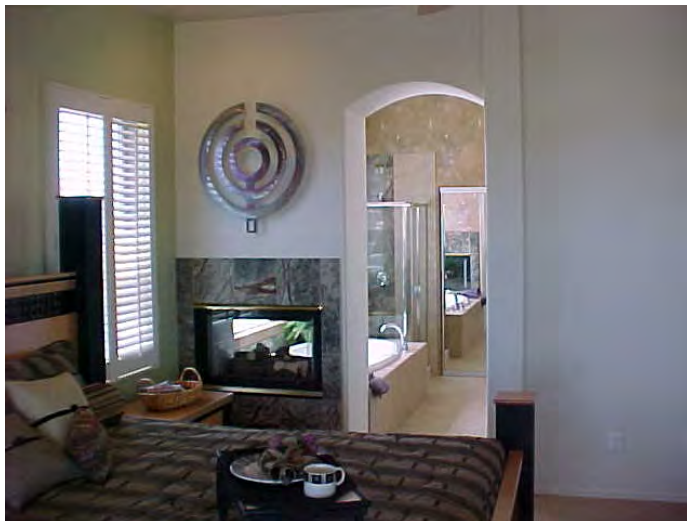

Computer wired homes, sound system wired homes, home theaters, vaulted or high flat ceilings, baseboard trim, wainscoting, cornice trim, overall amount of tile, size and number of closets, and overall quality of workmanship could tip the scales in the estimation of “quality indicator” or “grade.” The next several pages have pictures of family rooms with built-in shelves, some tile in the entry, average quality closets, walk-in closets with and without built in dresser, arched openings, rectangular openings, baseboard trim and cornice trim. Also, notice the picture of a home theater and a picture of a wine closet.

Built-in shelves.



Tile entry.



Built-in shelves.



Tile entry.

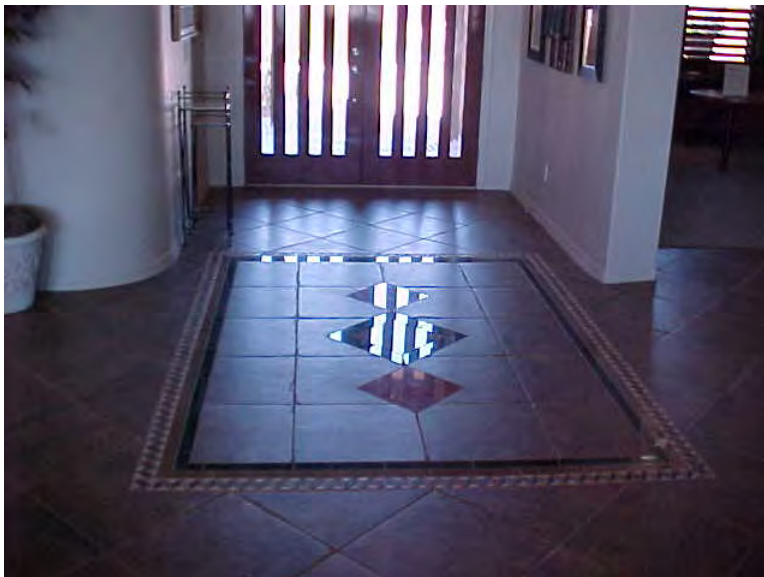

Average quality closet.



Walk-in closet with built-in dressers.



Average quality closet.



Walk-in closet with window.



Rectangular opening.



Arched openings.



3-inch baseboard trim.



Cornice trim.

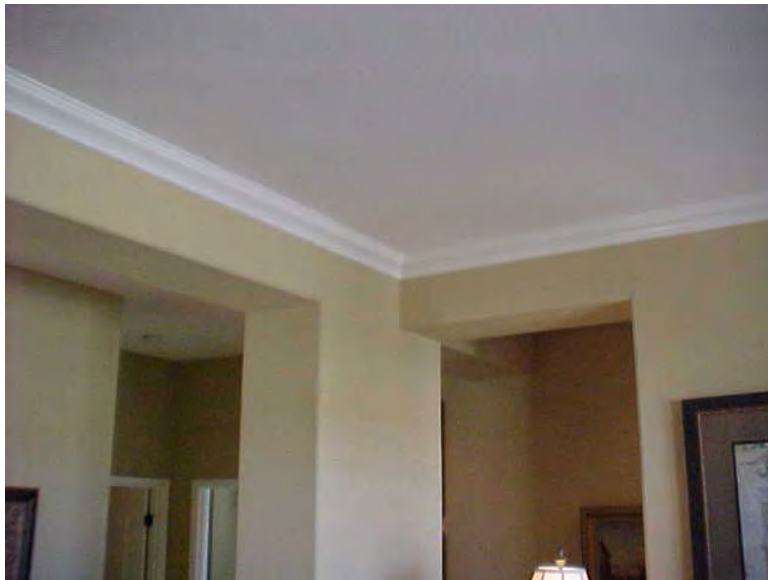

Home theater.



Wine closet.



Occasionally, exteriors and interiors have different “quality indicators”, so the appraiser must decide on the overall “quality indicator” and “grade.” Older homes may have updated kitchens and bathrooms not commensurate with the exterior. Conversely, some improvements may have a stronger exterior not indicative of a lesser quality interior. The next four pictures demonstrate the difference of quality on the exterior of a house and the interior of a house. The two pictures on this page show the exterior and remodeled kitchen of a home built circa 1940. The two pictures on the following page show a house built in 1998 with a strong exterior but a weak interior as evidenced by the minimal kitchen.

Circa 1940 house.



Circa 1940 house with remodeled kitchen.



1998 house.



1998 house with weak kitchen and interior.



Either scenario demonstrated above does not occur often because usually the interior of an improvement will mirror the same quality as the exterior, but the cost system has the flexibility to give a good estimate of cost for each scenario when necessary. The cost system will accommodate situations that have a difference in quality between exterior components and interior components. The square foot system places more emphasis on the opinion of the appraiser and increases productivity while reducing errors in the mass appraisal process. By using the principles found in this manual, appraisers with a range of experience will identify the correct "quality indicator" and "grade" for the improvement and will generate an accurate cost.

GOOD OR FAIR CHECKLIST

1. Roof design
2. Roof cover component
3. Pitch of roof
4. Window frame material
5. Bay Windows
6. Half circle windows
7. Number of windows
8. Size and quality of front door
9. Decorative brick or stone siding
10. 2 X 6 walls
11. Design of house (see footprint)
12. Front canopy
13. Height of Parapet on Santa Fe Style home
14. Amount of Tile
15. Ceiling height
16. Structured Wiring System (The Structured Wiring System allows for the integration of telephones, televisions, audio, security cameras, doorbell, intercoms, security systems, and a computer network.)
17. Quality and amount of countertops and cabinets in kitchen, laundry room, and bathrooms
18. Amount, size, and quality of interior trim
19. Quality of build-ins (refrigerator, range, cooktop/oven)
20. Number of electrical outlets and light fixtures

FINE TUNING QUALITY OF COMMERCIAL IMPROVEMENTS

Just as with residential improvements, part of the appraisal process for commercial properties includes the estimate of the overall “quality indicator” of improvements. With a range of quality of workmanship and quality of components to consider, at times, commercial improvements do not fit into a particular overall “quality indicator” category, so an appraiser may have to use the “grade” field to accommodate improvements that do not have a perfect fit. By adjusting the overall “quality indicator” with “fair grade” or “good grade,” an appraiser may accurately estimate improvement cost.

Due to the evolution of the Uniform Building Code, newer commercial improvements consist of some higher quality components and systems than older commercial improvements. Older commercial improvements have a tendency to fall in the Quality Indicator 2, average grade to Quality Indicator 3, fair grade range.

Many commercial improvements constructed after 1970 will fall into the Quality Indicator 3 average grade category with some having higher quality components and workmanship. Initially, we want to provide some direction in the use of the quality indicator and grade fields for Convenience Markets, Supermarkets, Motels, and Fast Food Restaurants.

Here are a few examples of how fast food restaurant, motel, convenience market and supermarket construction has evolved through the years.

60's Style Construction



Contemporary Construction



Note the lack of an interior eating area



The same Fast Food Restaurant Chain – 40 years later



Motels, or as they were originally called, Motor Courts, were small, individual cabin-like structures



A Modern Motel



A 1930's "Totem" Convenience Store



A Modern Convenience Store. Note the much larger square footage and storefront



This is a typical 1950's food market. Notice that it is about the same size as present day Convenience Markets



A Modern Supermarket – about 60,000 square feet



1 - Fast Food Restaurants

In its infancy, the fast food industry had mostly restaurants with just a walk up window and no sit down dining area. Gradually, minimal inside and outside dining areas began to appear to accommodate a growing clientele.

An increased volume of customers and menus that are more complex requires higher capacity electrical, plumbing and heating/cooling systems than in early fast food restaurants.

There are 5 construction characteristics that must be weighed to determine the quality indicator and grade.

1. Fenestration: both the quantity of storefront type windows and doors and their quality.
2. Architectural refinements: complex wall footprint, roof, wall and canopy treatments
3. Floor covering: ranging from terrazzo, ceramic tile, and carpet to vinyl tile squares.
4. Electric: both the amount of electric service and the quality of the lighting fixtures.
5. Plumbing: both the number and quality of the plumbing fixtures.

The next 6 photos show typical quality indicator 2 fast food restaurants.

This quality indicator 2 could be given a grade of good because of the extensive fenestration.





Outdoor dining consisted of covered patio areas or eating in a car under covered parking around the restaurant.



Now, note the difference in fenestration and architectural refinements in these quality indicator 3, grade average and above fast food restaurants.



Fast Food Restaurants replaced the walk-up window with the drive-through window.





Sit-down dining areas have continued to expand in fast food restaurants until they now rival the seating area of some full-service restaurants. Note the expensive lighting fixtures and tile floor.



Several fast food chains feature solar room window fenestration



Notice the tinted, anodized windows, the high parapet and the stepped canopy design.



Also, complexity of roof and footprint design as well as the size of fast food restaurants has also increased over the years.





Fast Food Restaurants went from shed roofs with roll roofing, to flat roofs with build-up roofing, and finally today, many have partial tile roofs.



2 – Motels

According to Marshall & Swift, quality differences in motels show, to the greatest degree, in a comparison of interiors. In summary, there are 5 key points to consider when deciding quality indicators and grade for motels.

1. The size of the quest rooms.
2. Size and quality of lobby, conference and breakfast rooms,
3. Quality of floor covering: good carpet, ceramic tile or vinyl tile.
4. Number and quality of plumbing fixtures: Ex. Wet bars, double sinks etc.
5. Amount of electrical wiring: Wiring for microwave, refrigerator, high speed internet access. Quality of lighting fixtures

Most motels with major chain names fall into the quality indicator 3, average grade category or better.





Higher quality motels, quality indicator 3, grade good and above, have inside access to the rooms and are 3 stories or less.





Typically, the higher quality motels have a small conference room and/or an upscale lobby.





The smaller and often times older motels with independent ownership will primarily fall into the Quality indicator 2, grade average to Quality Indicator 3, grade fair range. The older and lesser quality motels have outside access to the rooms.









Using the positive correlation between room size and quality will help an appraiser assign the proper quality indicator and grade. Typically, quality indicator 4 motels will have rooms between 350 square feet and 550 square feet with a median room size of 450 square feet. Quality indicator 3 motels will have rooms between 350 square feet and 450 square feet with a median room size of 400 square feet. Usually, quality indicator 2 motels will have rooms between 250 square feet to 400 square feet with a median room size of 350 square feet. In addition, larger rooms will likely have more electrical outlets, central air conditioning, a kitchen, and Internet connection.

Components that may indicate lesser overall quality would include an unusually narrow overhang, more than 10 percent vinyl flooring, and popcorn ceilings. Components that may indicate greater overall quality include an unusually wide overhang, more than 10 percent ceramic or quarry tile flooring, and tile roofing.





3 - Convenience Markets

Usually, not just one component will tip the scales to deviate from the default of grade average, but a combination of components. The 3 construction components of Convenience Markets that will most influence quality are:

1. The amount and quality of window and door fenestration.
2. The quality of the floor cover: carpet, ceramic or vinyl tile.
3. The existence and quality of a front canopy.

Most “mom and pop” owned convenience stores fall into the quality indicator 2 grade average to quality indicator 3, grade fair category.





Many were former national chain convenience stores





Typically, convenience stores with a major national chain name will fall into the quality indicator 3, grade average or better category. Please do not confuse quality of components and quality of workmanship with condition. Depreciation will adjust for condition. Quality indicator and grade will adjust for quality.



Components that indicate overall better quality include amount of ceramic tile flooring, size of storefront and size and quality of the canopy. Over 50% ceramic tile flooring would increase cost enough to consider quality indicator 3, good grade.



Storefronts of greater than 20% of total wall area would be found in quality indicator 3, good grade category or better.



Canopy widths of greater than 6 feet would also be found in quality indicator 3, good grade or better.



Components that indicate lesser overall quality include lack of flooring, storefront and canopy.
Canopy widths of less than two feet,



Storefronts of less than 10% of wall area, and over 50% of a floor covered with hardener/sealer could reduce cost enough to consider a range of quality indicator 2, average grade to quality indicator 3, fair grade.



Quality and the wall height of convenience stores have a positive correlation. Typically, quality indicator 3, grade fair or below will have a wall height of ten feet or shorter. Quality indicator 3, grade average will have a wall height of ten feet to 12 feet. Quality indicator 3, grade good will have a wall height of 12 feet or more.

Flooring contributes substantially to the overall cost of the convenience market. The spectrum of cost goes from hardener/sealer for quality indicator 3, grade fair and below to asphalt and vinyl tile for quality indicator 3, grade average to ceramic tile for quality indicator 3, grade good and above.

4 - Supermarkets

Most modern supermarkets have a lot of square feet under a big box. This property type lends itself well to the square foot enhancement of the Construction Cost System. Most of the supermarket chains have little variation in quality of components and quality of workmanship. However, there are 5 construction characteristics that can aid the appraiser in determining quality indicator and grade.

1. The amount and quality of window and door fenestration.
2. The amount of ornamentation in the front canopy and wall area. This extra quality will typically carry through to the interior.
3. The quality of the interior flooring; terrazzo, pavers, wood plank and highly patterned vinyl all are indicative of higher quality.
4. The amount and quality of the lighting; not just the florescent tubes but also the accent lighting.
5. The amount of plumbing, quality of the plumbing fixtures and the amount of specialized electric. The presence of butcher's work areas, deli, snack bar, bakery, break room and bank all require additional plumbing and electrical service.







As with the other models, usually the inferior or superior quality of more than one component will make you consider grade fair or grade good. Some components that vary greatly in the same improvement may actually cancel themselves, and bring you back to the default of grade average.





A supermarket without storefront and canopy with hardener and sealer floor cover would make an appraiser at least consider quality indicator 2, grade fair or average. Older supermarkets will typically fall into this category as the following photos show.





An appraiser should associate elastomeric roof cover, tile floor cover, a large canopy and large storefront with grade good. Although none of these components would contribute enough cost by themselves to change the grade field to good, a combination of those components could add enough cost to tip the scales in favor of grade good. Typically, supermarkets have between 25% and 50% of frame structure. If the frame structure present in the supermarket goes above 65%, the appraiser should consider grade good. Frame structure adds a lot of cost to a building.





Again, modern supermarkets will not have a lot of variation in construction components or quality of workmanship, so most will not need changing from the default of grade average. Most of the time, the superior components will cancel out the inferior components, so the supermarket model lends itself very well to the square foot enhancement.

PROCEDURES FOR ENTERING MOBILE HOMES, MOBILE HOME ADDITIONS AND MOBILE HOME YARD IMPROVEMENTS INTO THE CONSTRUCTION COST SYSTEM USING THE SQUARE FOOT ENHANCEMENT

The following models, procedures and components have been added to the Construction Cost System and are available for use at the discretion of the Assessor. The key features of this system include:

- Uses Replacement Cost New as provided by Marshall & Swift rather than Factory List Price.
- Functional quality indicators and grades.
- Different depreciation schedules for Singlewide and Doublewide Mobiles.
- Depreciation tables calibrated on affixed home sales.

ADDED MODELS

881-x Singlewide Mobile Home
 882-x Doublewide Mobile Home
 883-x SF Mobile Home Yard Improvements
 884-x SF Mobile Home Room Addition

ADDED COMPONENTS

All square foot mobile home components have a 4 character component code.

The first character will either be:

S=Singlewide
 D=Doublewide
 T=Tagalong

The second character will be the type of siding:

L=Lap Siding
 A=Aluminum Siding
 S=Stucco Siding
 W=Log Siding

The third and fourth characters will be the width of the unit or section.

Singlewide widths: 08, 12, 14, 16, 18
 Doublewide widths: 20, 24, 28, 32, 36

For example, the component code for a 28-foot wide doublewide with lap siding is DL28. If the width of the mobile is between the allowed widths, use the larger width. Enter the square footage of the mobile home or tagalong in the units field.

Basic Procedure

Using the Mobile Home Square Foot Data Collection Form, complete a detailed baseline including perimeter, square footage and average story height. Enter any obsolescence, modernization or physical condition adjustment just as in a site built listing. List the appropriate square foot component(s), using the above chart as a guide. A triplewide will require 2 components, a doublewide and a tagalong. A fourwide should be listed as 2 doublewides.

Models 881x and 882x should **only** be used for listing the mobile home square foot components. All other components should be listed using the 883x(SF Mobile Home Yard Improvements) and 884x(SF Mobile Home Room Addition) models and separate square foot forms.



VOLUME II

CONSTRUCTION COST MANUAL

State of Arizona

**Copyright 2009 by Marshall and Swift.
All Rights Reserved.**

Marshall & Swift/Boeckh retains all proprietary, copyright and other rights to the cost data shown.

Selected graphics reprinted from the Marshall Valuation Service (copyright 2009) and the Residential Cost Handbook (copyright 2009), by permission of the publisher, Marshall & Swift.

A BRICK MASONRY WALL (SF Basement Wall Area)

Thickness Range: 6"–36" Required in miscellaneous field.

A basement wall constructed of some type of brick into a solid masonry wall or cavity wall that has been reinforced and grout filled. Wall thickness varies depending on the structural requirements of the building, but generally it is between 8 and 12 inches.

Cost does not include waterproofing or insulation.

The quality of the interior finish and the quantity and quality of openings should be considered when selecting a rank.

ABA STAINED GLASS WINDOW (SF Area)

Painted and fired art glass with minimum field and borders. The smallest dimension of the dominant pieces is 4 inches or greater.

ABB STAINED GLASS WINDOW (SF Area)

Painted and fired art glass with a minimum field and borders. The smallest dimension of the dominant pieces is between 2 and 4 inches.

ABC STAINED GLASS WINDOW (SF Area)

Minimum painted and fired art glass, field, and borders, with the smallest dimension of the dominant pieces being less than 2 inches.

AGA STAINED GLASS WINDOW (SF Area)

Plain mosaic art glass, made of regular pieces with few embellishments. Smallest dimension of the dominant pieces is 4 inches or greater.

AGB STAINED GLASS WINDOW (SF Area)

Plain mosaic art glass, made of regular pieces with few embellishments. Smallest dimension of the dominant pieces is between 2 and 4 inches.

AGC STAINED GLASS WINDOW (SF Area)

Plain mosaic art glass, made of regular pieces with few embellishments. Smallest dimension of the dominant pieces is less than 2 inches.

AGD STAINED GLASS WINDOW (SF Area)

Contemporary abstract art glass with the smallest dimension of the dominant pieces being 4 inches or greater.

AGE STAINED GLASS WINDOW (SF Area)

Contemporary abstract art glass with the smallest dimension of the dominant pieces being between 2 and 4 inches.

AGF STAINED GLASS WINDOW (SF Area)

Contemporary abstract art glass with the smallest dimension of the dominant pieces being less than 2 inches.

APK KITCHEN, SINGLE UNIT (EA)

A self-contained appliance center with a compact refrigerator, range, and sink in a prefabricated cabinet.

The size of the unit should be considered when selecting a rank. The higher ranks include a wall cabinet.

APP APPLIANCE ALLOWANCE (EA Kitchen)

This cost includes consideration for the appliances commonly found in apartments. Typically ranges and ovens, garbage disposers, dishwashers, and range hoods are included. The better qualities (higher cost ranks) have additional feature considerations for trash compactors, microwaves, built-in mixer units, etc.

For refrigerators, use component code UM.

APPC CLOTHES WASHER–DRYER COMBINATION (EA)

Cost includes consideration for the clothes washer–dryer combination commonly found in an apartment or single family residence.

APPD CLOTHES DRYER (EA)

Cost includes consideration for the clothes dryer commonly found in an apartment or single family residence.

APPW CLOTHES WASHER (EA)

Cost includes consideration for the clothes washer commonly found in an apartment or single family residence.

ATM AUTOMATED TELLER MACHINE, DRIVE-UP OR THROUGH-WALL (EA)

A mechanical device capable of depositing and dispensing cash. These machines are located on the exterior wall of a building or on an island. Operating accessories are included in the cost.

Cost does not include demolition and installation in existing facilities or protective guardrails or barriers.

For freestanding interior teller machines, use component ATS.

ATS AUTOMATED TELLER MACHINE, LOBBY OR RETAIL UNIT (EA)

A mechanical device capable of depositing and dispensing cash. These are freestanding machines located in the interior of a banking or retail facility. Operating accessories are included in the cost. For teller machines located on the exterior of a building or on an island, use component ATM.

B CONCRETE BLOCK WALL (SF Basement Wall Area)

Thickness Range: 6"–36" Required in miscellaneous field.

A concrete block basement wall with a typical thickness of between 8 and 12 inches. Thickness of wall is generally based on the design and structural considerations of the building.

Cost does not include waterproofing or insulation.

The quality of the interior finish and the quantity and quality of openings should be considered when selecting a rank.

BA EXCAVATION (CF)

This component is for bulk excavation as opposed to trenching for foundations. Costs vary according to type of soil, accessibility of the site, and length of haul for the disposal.

Rank 1 should be used if the soil is easy to dig and the dirt can be wasted on site.

Rank 2 and 3 should be used for harder soil and longer hauls.

Rank 4 should be used if there are difficult conditions, such as very hard soil or rock, or perhaps sandy soil that requires much shoring.

BB FILL (CF)

Soil brought to the building site to change the topography or to alter the structural strength of the soil on site, e.g., the fill for a dock-height floor. The cost includes compaction of the fill material and transportation.

The distance that the soil must be hauled should be considered when selecting a rank.

BC SITE PREPARATION (SF Ground Floor Area)

Site preparation that consists of simple clearing and leveling. Use this component when BA (excavation) or BB (fill) is not applicable to the estimate.

BCC BALCONIES, CHURCH INTERIOR (SF Area)

A stepped platform for seating constructed of wood, concrete, steel, or wood and steel. The cost includes floor finish, lighting, railing, and soffit finish.

Cost does not include seating or heating.

Rank is usually commensurate with the building.

BCD BALCONIES, AUDITORIUM INTERIOR (SF Balcony Area)

Restrictions: Classes A, B, C, and D only

This is typically a stepped balcony with a finished soffit. The cost includes some consideration for lighting.

BCT BALCONIES, THEATER INTERIOR (SF Balcony Area)

Restrictions: Classes A, B, C, and D only

This is a stepped balcony with finished floors. The soffit has some type of finish, e.g., plaster. Light fixtures may be sidewall- or ceiling-mounted.

BDA BALCONY, CONCRETE (SF Balcony Area)

An exterior balcony constructed of poured-in-place or precast concrete deck. The cost includes a prorated allowance for railing.

The intricacy of the balcony design should be considered when selecting a rank.

BDB BALCONY, STEEL (SF Balcony Area)

An exterior balcony constructed of steel frame with metal grate or concrete deck. The cost includes a prorated allowance for the railing.

The balcony design should be considered when selecting a rank.

BDC BALCONY, WOOD (SF Balcony Area)

An exterior balcony constructed of wood frame and wood deck. The cost includes a prorated allowance for the railing.

Rank 1 is wood only.

Rank 4 has concrete cover.

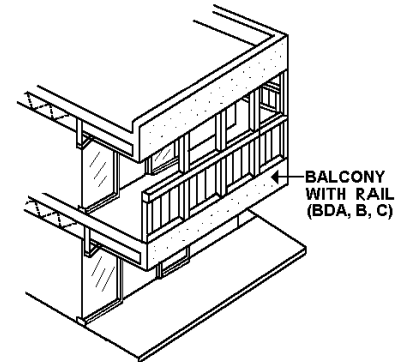

BST BASEMENT (SF Basement Area)

Restrictions: Residential models only
7' to 9' wall height
Size: 50–4000 SF floor area

Includes excavation, backfill, foundation, footing, concrete block wall, waterproofing, concrete floor, floor drain, wood or steel pipe columns to support the living area above, minimum electrical, and an open-riser stairway.

Add for interior finish (NO, NP, NQ), ceiling, and plumbing.

BUM PARKING LOT BUMPERS (LF)

These are precast concrete bumpers installed in individual parking spaces that are anchored to the pavement by spikes, pipes, or reinforcing bars.

C CONCRETE REINFORCED WALL (SF Basement Wall Area)

Thickness Range: 6"—36" Required in miscellaneous field.

A concrete basement wall that is reinforced with re-bar. The thickness of wall is generally based on the design and structural considerations of the building.

Cost does not include waterproofing or insulation.

The quality of the interior finish and the quantity and quality of openings should be considered when selecting a rank.

Soil Bearing Capacity—Adjustments to foundation components are a suffix, in 3rd or 4th position, of X, Y, or Z.

X—Indicates soils with a load-bearing capacity of less than 2,500 pounds per square foot. Such soils normally include loam, clay loam, cobbly loam, gravelly loam, and sandy loam.

Y—Indicates soils with load-bearing capacity range 2,500 to 4,000 pounds per square foot. Such soils normally include sandy loam, gravelly loam, hardpan, limy loam, limy and sandy loam, and bedrock.

Z—Indicates soils with load-bearing capacity greater than 4,000 pounds per square foot. Such soils normally include gravelly sand.

If soil-bearing capacity is unknown, use component without any X, Y, or Z indication.

CA CONCRETE, NONBEARING (SF)

A concrete foundation for a fully framed building in which the walls are non-load-bearing. The weight of the structure is transmitted through the frame to the foundation. The cost includes excavation, trenching, forming, reinforcing, concrete and backfill required for both perimeter and interior footings, and foundation.

Enter the square feet of the floor.

Rank is influenced by:

- Load supported; the greater the load, the higher the rank
- Size and shape; the higher the ratio of the perimeter to floor area, the higher the rank
- Topography; stepped foundations require a higher rank
- Climate; the deeper the frost line, the higher the rank

To designate soil bearing capacity, use X, Y, or Z.

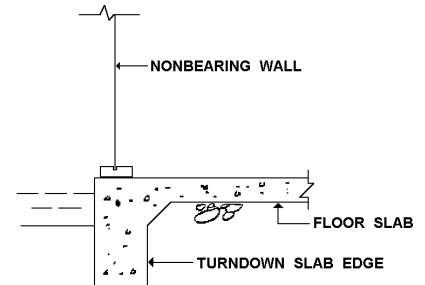

CAB CONCRETE BEARING WALLS (SF)

Restrictions: Class C only

May also be used for the bearing wall portion of a Class A, B, C, or S partially framed building.

A concrete foundation for a building that has bearing walls supporting the upper floor(s) and roof structure. The cost includes excavation, trenching, forming, reinforcing, concrete and backfill required for both perimeter and interior footings, and foundation.

Enter the square feet of floor area.

Rank is influenced by:

- Load supported; the greater the load, the higher the rank
- Size and shape; the higher the ratio of the perimeter to floor area, the higher the rank
- Topography; stepped foundations require a higher rank
- Climate; the deeper the frost line, the higher the rank

To designate soil bearing capacity, use X, Y, or Z.

For Class D buildings, use one of the following components:

- CAE Concrete, siding, or stucco bearing walls
- CAF Concrete, masonry veneer bearing walls

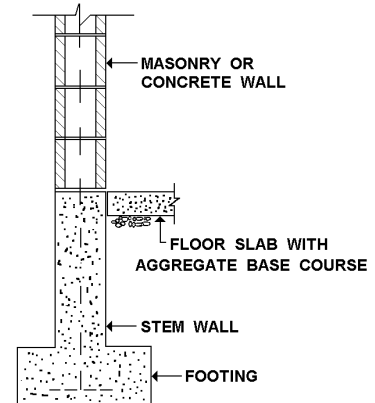
**CAC OPEN SHELL TYPE, CONCRETE (SF)**

Restrictions: Classes C, D, and S only

A concrete foundation for a large, open building. The perimeter foundation may carry all of the load. The cost includes excavation, trenching, forming, reinforcing, concrete and backfill required for both perimeter and interior footings, and foundation.

Enter the square feet of floor area.

Rank is influenced by:

- Load supported; the greater the load, the higher the rank
- Size and shape; the higher the ratio of the perimeter to floor area, the higher the rank
- Topography; stepped foundations require a higher rank
- Climate; the deeper the frost line, the higher the rank

To designate soil bearing capacity, use X, Y, or Z.

CAD CONCRETE, POLE TYPE (SF)

Restrictions: Class D pole frame only

A concrete foundation for a fully framed finished pole frame building. The walls are non-load-bearing. The weight of the structure is transmitted to the foundation through the pole frame. The cost includes excavation, trenching, forming, reinforcing, concrete and backfill required for both perimeter and interior footings, and foundations.

Enter the square feet of floor area.

Rank is influenced by:

- Load supported; the greater the load, the higher the rank
- Size and shape; the higher the ratio of the perimeter to floor area, the higher the rank
- Topography; stepped foundations require a higher rank
- Climate; the deeper the frost line, the higher the rank

To designate soil bearing capacity, use X, Y, or Z.

CAE CONCRETE, SIDING—STUCCO (SF)

Restrictions: Class D, siding and stucco only

A concrete foundation for a building that has bearing walls supporting the upper floor(s) and roof structure.

The cost includes excavation, trenching, forming, reinforcing, concrete and backfill required for both perimeter and interior footings, and foundation.

Enter the square feet of the floor area.

Rank is influenced by:

- Load supported; the greater the load, the higher the rank
- Size and shape; the higher the ratio of the perimeter to floor area, the higher the rank
- Climate; the deeper the frost line, the higher the rank

To designate soil bearing capacity, use X, Y, or Z.

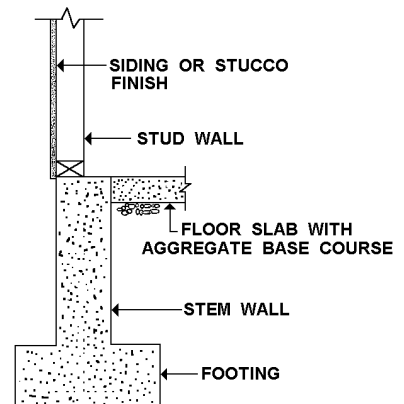

CAF CONCRETE, MASONRY VENEER (SF)

Restrictions: Class D, masonry veneer only

A concrete foundation for a building that has bearing walls supporting the upper floor(s) and roof structure. The cost includes excavation, trenching, forming, reinforcing, concrete and backfill required for both perimeter and interior footings, and foundation.

Enter the square feet of floor area.

Rank is influenced by:

- Load supported; the greater the load, the higher the rank
- Size and shape; the higher the ratio of the perimeter to floor area, the higher the rank
- Topography; stepped foundations require a higher rank
- Climate; the deeper the frost line, the higher the rank

To designate soil bearing capacity, use X, Y, or Z.

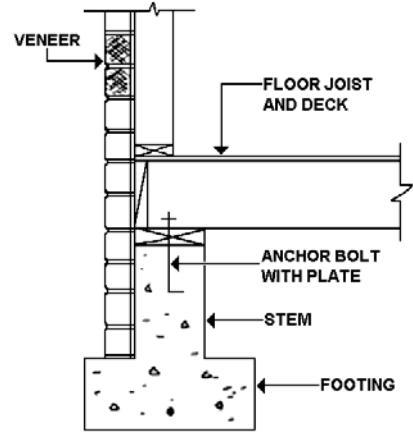

CAG TREATED WOOD, MASONRY VENEER (SF)

Restrictions: Class D, masonry veneer only
Residential and Farm models only

A pressure-treated wood foundation for a bearing wall Class D masonry veneer building. The cost includes perimeter footing and sheathed stem wall, as well as any interior footings required for support.

Enter the square feet of floor area.

Rank is influenced by:

- Use higher rank for concrete footing in place of gravel footing
- Load supported; the greater the load, the higher the rank
- Size and shape; the higher the ratio of the perimeter to floor area, the higher the rank
- Topography; stepped foundations require a higher rank
- Climate; the deeper the frost line, the higher the rank

To designate soil bearing capacity, use X, Y, or Z.

CAH TREATED WOOD, SIDING/STUCCO (SF)

Restrictions: Class D, siding/stucco only
Residential and Farm models only

A pressure-treated wood foundation for a bearing wall Class D siding/stucco building. The cost includes perimeter footing and sheathed stem wall, as well as any interior footings required for support.

Enter the square feet of floor area.

Rank is influenced by:

- Use a higher rank for concrete footing in place of gravel footing
- Load supported; the greater the load, the higher the rank
- Size and shape; the higher the ratio of the perimeter to floor area, the higher the rank
- Topography; stepped foundations require a higher rank
- Climate; the deeper the frost line, the higher the rank

To designate soil bearing capacity, use X, Y, or Z.

CAPC CAISSON, CONCRETE (LF@DIAMETER)

Size Range: 12" to 48" Diameter

A drilled, cylindrical foundation shaft used to transfer a load through soft strata to bedrock. The shaft is filled with concrete.

CAS ANIMAL SHELTER (SF)

A shelter for animals found in conjunction with agricultural improvements. Cost Includes site preparation, column footings, light pole frame, open wood roof system, and roof cover.

CASB STOCK CORRALS, WOOD POSTS AND RAILS (LF)

Generally found on agricultural property. Cost includes wood posts and wood rails.

CASC STOCK CORRALS, METAL POSTS AND RAILS (LF)

Generally found on agricultural property. Cost includes metal posts and metal rails (succor rod; pipe and cable).

CASD STOCK CORRAL GATE (EA)

Generally found on agricultural property. Cost includes metal or wood frame with 3 to 4 rails, hinges, and latch. Gates are 8 to 10 feet in length.

-
- CASE HORSE CORRAL FENCE (LF)**
- Generally found on agricultural property. Cost includes wood or metal frame with 3 to 5 rails.
- CASF CATTLE SQUEEZE (EA)**
- A wood or steel structure used to single out livestock for confinement.
- CASG HORSE CORRAL GATE, VINYL (EA)**
- Generally found on agricultural property. Cost includes solid vinyl frame with 3 to 4 rails, hinges, and latch. Gates are 8 to 10 feet in length.
- CASH HORSE WALKER (EA)**
- A steel structure that pivots on a center post and is designed to exercise 1 to 4 horses at a time.
- CASI WATER TROUGH (LF)**
- A wood, steel, or concrete livestock watering trough. Cost rank is influenced accordingly.
- CASJ WATER TANKS, GALVANIZED (EA)**
- Generally found on agricultural property.
- Rank 1 for 150–gallon tank.
Rank 2 for 200–gallon tank.
Rank 3 for 300–gallon tank.
Rank 4 for 500–gallon tank.
- CASM ROOF FOR FEEDING TROUGHS (ADD; LF)**
- Cost includes roof structure, roof cover, vertical supports, and all necessary footings. Average roof width is 10 feet. Use with components CASP, CASQ, CASR, CASS, CAST, and CASU.
- Use lower ranks for wood structures and higher ranks for metal structures.
- CASN BARBED WIRE FENCING (LF)**
- Cost includes either wood or metal posts and 1 to 5 strands of wire.
- CASP FEEDING TROUGH, WOOD, 1–SIDED BUNK (LF)**
- Generally found in feedlots and other agricultural uses. Cost includes a wood trough and fencing on 1 side of the trough only. Use component CASM for roof structure

CASQ FEEDING TROUGH, STEEL, 1–SIDED BUNK (LF)

Generally found in feedlots and other agricultural uses. Cost includes a steel trough and fencing on 1 side of the trough only. Use component CASM for roof structure.

CASR FEEDING TROUGH, CONCRETE, 1–SIDED BUNK (LF)

Generally found in feedlots and other agricultural uses. Cost includes a concrete trough and fencing on 1 side of the trough only. Use component CASM for roof structure.

CASS FEEDING TROUGH, WOOD, 2–SIDED BUNK (LF)

Generally found in feedlots and other agricultural uses. Cost includes a wood trough that allows feeding from both sides of the trough. Use component CASM for roof structure.

CAST FEEDING TROUGH, STEEL, 2–SIDED BUNK (LF)

Generally found in feedlots and other agricultural uses. Cost includes a steel trough that allows feeding from both sides of the trough. Use component CASM for roof structure.

CASU FEEDING TROUGH, CONCRETE, 2–SIDED BUNK (LF)

Generally found in feedlots and other agricultural uses. Cost includes a concrete trough that allows feeding from both sides of the trough. Use component CASM for roof structure.

CASV HORSE CORRAL FENCE, VINYL (LF)

Generally found on agricultural property. Cost includes solid vinyl posts and rails.

Rank 2 for 3–rail.

Rank 4 for 4–rail.

CASX CATTLE FEEDER / FENCING (LF)

Tubular steel fencing found on dairies and feedlots that is designed to allow cattle to feed through the fence. Higher quality fencing will also have a mechanism that locks in the animal's head for veterinary or inspection purposes. Use Rank 1 for simple feeder fencing. Use Rank 4 for fencing with locking mechanism. Cost includes concrete footings or stemwall and support posts.

CB WOOD BLOCKS AND SILLS (SF)

Restrictions: Class D Residential and Farm models only

A wood foundation composed of a treated wood sill or block framing members that are resting directly on the earth. Referred to as a mud sill foundation.

Enter the square feet of floor area.

Rank is influenced by:

- Load supported; the greater the load, the higher the rank
- Size and shape; the higher the ratio of the perimeter to floor area, the higher the rank
- Topography; stepped foundations require a higher rank
- Climate; the deeper the frost line, the higher the rank

To designate soil bearing capacity, use X, Y, or Z.

CBA WOOD SILLS (LF)

Restrictions: Class D
Residential (010-0) and Farm models only

A wood foundation composed of a treated wood sill framing member that is resting directly on the earth. Referred to as a mud sill foundation.

Enter linear feet of foundation.

Rank is influenced by:

- Load supported; the greater the load, the higher the rank
- Topography; stepped foundations require a higher rank
- Climate; the deeper the frost line, the higher the rank

To designate soil bearing capacity, use X, Y or Z.

CC CONCRETE (LF)

Restrictions: Classes C, D, and S only

A concrete foundation for Class C, D, or S buildings, where a perimeter stem or heavy grade beam carries all of the load. Cost includes excavation, trenching, forming, reinforcing, concrete, and backfill.

Cost does not include column footing.

Enter linear feet of foundation.

Rank is influenced by:

- Load supported; the greater the load, the higher the rank
- Topography; stepped foundations require a higher rank
- Climate; the deeper the frost line, the higher the rank

To designate soil load-bearing capacity, use X, Y, or Z.
For column footings supporting a roof or floor load, use components CD, CDA, CE, CAE, and CF.

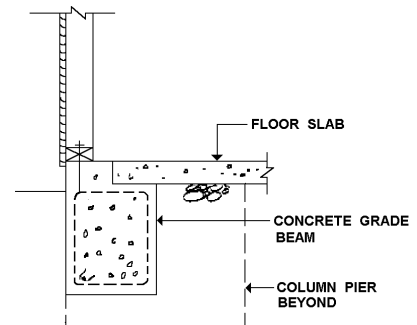

CCE CONCRETE, SIDING—STUCCO (LF)

Restrictions: Class D, siding—stucco only

A concrete foundation for Class D buildings, where a perimeter stem or heavy grade beam carries all of the load. The cost includes excavation, trenching, forming, reinforcing, concrete, and backfill.

Cost does not include column footings.

Enter linear feet of foundation.

Rank is influenced by:

- Load supported; the greater the load, the higher the rank
- Topography; stepped foundations require a higher rank
- Climate; the deeper the frost line, the higher the rank

To designate soil bearing capacity, use X, Y, or Z.

For column footings supporting a roof or floor load, see components CD, CDA, CE, CAE, and CF.

CCF CONCRETE, MASONRY VENEER (LF)

Restrictions: Class D, masonry veneer only

A concrete foundation for large, open Class D buildings, where a perimeter stem or heavy grade beam carries all of the load. The cost includes excavation, trenching, forming, reinforcing, concrete, and backfill.

Cost does not include column footings.

Enter linear feet of foundation.

Rank is influenced by:

- Load supported; the greater the load, the higher the rank
- Topography; stepped foundations require a higher rank
- Climate; the deeper the frost line, the higher the rank

To designate soil bearing capacity, use X, Y, or Z.

For column footings supporting a roof or floor load, use components CD, CDA, CE, CAE, and CF.

CCG TREATED WOOD, MASONRY VENEER (LF)

Restrictions: Class D, masonry veneer
Residential and Farm models only
A pressure-treated wood foundation for Class D buildings, where a perimeter wall carries all of the load. The cost includes excavation, trenching, treated wood members, and backfill required for both continuous perimeter and interior footings, and foundation. Cost does not include column footings.

Enter linear feet of foundation.
Rank is influenced by:
—Load supported; the greater the load, the higher the rank
—Topography; stepped foundations require a higher rank
—Climate; the deeper the frost line, the higher the rank

To designate soil bearing capacity, use X, Y, or Z.

CCH TREATED WOOD, SIDING OR STUCCO (LF)

Restrictions: Class D, siding–stucco
Residential and Farm models only
A pressure-treated wood foundation for Class D buildings, where a perimeter wall carries all of the load. The cost includes excavation, trenching, treated wood members, and backfill required for both continuous perimeter and interior footings, and foundation.

Cost does not include column footings.
Enter linear feet of foundation.
Rank is influenced by:
—Load supported; the greater the load, the higher the rank
—Topography; stepped foundations require a higher rank
—Climate; the deeper the frost line, the higher the rank

To designate soil bearing capacity, use X, Y, or Z.

CCJ LIGHT REINFORCED GRADE BEAM (LF)

Restrictions: Classes C, D, and S only
A concrete foundation for Classes C, D, or S buildings, where a light reinforced grade beam carries all of the load. The cost includes excavation, trenching, forming, reinforcing, concrete, and backfill. Cost does not include column footings.

Enter linear feet of foundation.
Rank is influenced by:
—Load supported; the greater the load, the higher the rank
—Topography; stepped foundations require a higher rank
—Climate; the deeper the frost line, the higher the rank

To designate soil bearing capacity, use X, Y, or Z.
For column footings supporting a roof or floor load, use components CD, CDA, CE, CAE, and CF.

CCK UNREINFORCED GRADE BEAM (LF)

Restrictions: Class C, D, and S only
Residential and Farm models only

A concrete foundation for Class C, D, or S buildings, where a light unreinforced grade beam carries all of the load. The cost includes excavation, trenching, forming, concrete, and backfill.

Cost does not include column footings.

Enter linear feet of foundation.

Rank is influenced by:

- Load supported; the greater the load, the higher the rank
- Topography; stepped foundations require a higher rank
- Climate; the deeper the frost line, the higher the rank

To designate soil bearing capacity, use X, Y, or Z.

For column footings supporting a roof or floor load, use components CD, CDA, CE, CAE, and CF.

CD CONCRETE COLUMN FOOTINGS, WOOD COLUMNS (EA)

Restrictions: Classes C and D, wood columns only

Concrete footings to support structural wood columns in Class C and D buildings. The cost includes excavation, forming, reinforcing, concrete, and backfill.

Enter number of column footings.

Rank is influenced by:

- Load supported; the greater the load, the higher the rank
- Topography; stepped foundations require a higher rank
- Climate; the deeper the frost line, the higher the rank

To designate soil bearing capacity, use X, Y, or Z.

For continuous foundations use components CC, CCE, CCF, CCJ, CCG, CCH, and CCK.

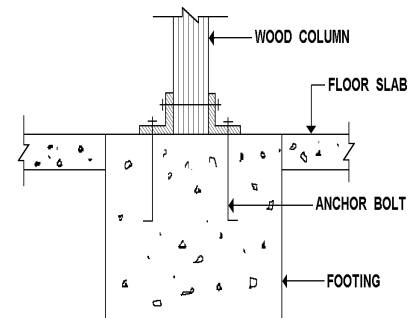

**CDA CONCRETE COLUMN FOOTING, WOOD COLUMN,
LIGHT POLE (EA)**

Restrictions: Class D, wood pole only

Column supporting holes to support wood pole frame in Class D buildings. This component is for the hole only.

Rank 1 when the hole is filled with backfill.

Rank 4 when the hole is filled with gravel and concrete.

To designate soil bearing capacity, use X, Y, or Z.

For continuous foundations, use CCE, CCJ, and CCK.

**CDB CONCRETE COLUMN FOOTINGS, WOOD COLUMN,
LIGHT POLE (SF)**

Restrictions: Class D, wood pole only
Farm models only

Column holes to support wood pole frame in Class D buildings where there is no continuous foundation. This component is the hole only.

Rank 1 when the hole is filled with backfill.

Rank 4 when the hole is filled with gravel and concrete.

To designate soil bearing capacity, use X, Y, or Z.

**CDC CONCRETE COLUMN FOOTINGS—WOOD COLUMNS
(SF)**

Restrictions: Classes C and D, wood columns only
Farm models only

Concrete footings to support structural wood columns where there is no continuous foundation. The cost includes excavation, forming, reinforcing, concrete, and backfill.

Rank is influenced by:

—Load supported; the greater the load, the higher the rank

—Topography; stepped foundations require a higher rank

—Climate; the deeper the frost line, the higher the rank

To designate soil bearing capacity, use X, Y, or Z.

CDD PIERS, CONCRETE FOOTING (SF)

Restrictions: Class D
Residential and Farm models only

A pier foundation composed of a precast concrete pier that is resting directly on the earth.

Rank is influenced by:

- Load supported; the greater the load, the higher the rank
- Size; the larger the pier and closer the spacing, the higher the rank
- Topography; stepped foundations require a higher rank
- Climate; the deeper the frost line, the higher the rank

To designate soil bearing capacity, use X, Y, or Z.

CDE PIERS, CONCRETE FOOTING (LF)

Restrictions: Class D
Residential and Farm models only

A pier foundation composed of a precast concrete pier that is resting directly on the earth.

Rank is influenced by:

- Load supported; the greater the load, the higher the rank
- Size; the larger the pier and closer the spacing, the higher the rank
- Topography; stepped foundations require a higher rank
- Climate; the deeper the frost line, the higher the rank

To designate soil bearing capacity, use X, Y, or Z.

CE CONCRETE COLUMN FOOTINGS, STEEL COLUMNS (EA)

Restrictions: Class C, D, and S, steel columns only

Concrete footings to support structural steel columns. The cost includes excavation, forming, reinforcing, concrete, and backfill.

Rank is influenced by:

- Load supported; the greater the load, the higher the rank
- Topography; stepped foundations require a higher rank
- Climate; the deeper the frost line, the higher the rank

To designate soil bearing capacity, use X, Y, or Z.

For continuous foundations, use components CC, CCE, CCF, CCJ, and CCK.

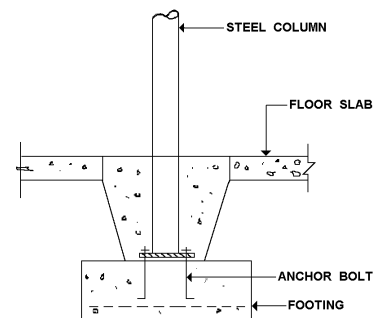

CEA CONCRETE COLUMN FOOTING, STEEL COLUMN, LIGHT PRE-ENGINEERED (EA)

Restrictions: Class C, D, and S, steel columns only

Concrete footings to support light pre-engineered structural steel frame in Class C, D, and S buildings. The cost includes excavation, forming, reinforcing, concrete, and backfill.

Rank is influenced by:

- Load supported; the greater the load, the higher the rank
- Topography; stepped foundations require a higher rank
- Climate; the deeper the frost line, the higher the rank

To designate load-bearing capacity, use X, Y, or Z.

For continuous foundations, use components CC, CCE, CCF, CCJ, and CCK.

CEB CONCRETE COLUMN FOOTING, STEEL COLUMN PRE-ENGINEERED (SF)

Restrictions: Class C, D, and S, steel columns only
Farm models only

Concrete footings to support light pre-engineered structural steel frame buildings where there is no continuous foundation. The cost includes excavation, forming, reinforcing, concrete, and backfill.

Rank is influenced by:

- Load supported; the greater the load, the higher the rank
- Topography; stepped foundations require a higher rank
- Climate; the deeper the frost line, the higher the rank

To designate soil bearing capacity, use X, Y, or Z.

CF CONCRETE COLUMN FOOTINGS—CONCRETE COLUMNS (EA)

Restrictions: Class C, concrete columns only

Concrete footings to support structural concrete columns. Cost includes excavation, forming, reinforcing, concrete, and backfill.

Rank is influenced by:

- Load supported; the greater the load, the higher the rank
- Topography; stepped foundations require a higher rank
- Climate; the deeper the frost line, the higher the rank

To designate soil bearing capacity, use X, Y, or Z.

For continuous foundations, use components CC, CCJ, and CCK.

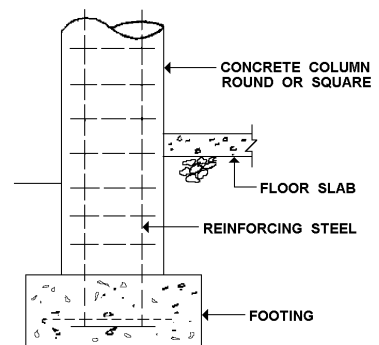

CJ MASONRY (SF)

Restrictions: Classes C, D, and S only

A masonry brick or stone foundation for a building that has bearing walls supporting the upper floor(s) and roof structure. The cost includes excavation, trenching, forming, reinforcing, concrete and backfill required for both perimeter and interior footings, and foundation.

Enter the square foot of floor area.

Rank is influenced by:

—Load supported; the greater the load, the higher the rank

—Size and shape; the higher the ratio of the perimeter to floor area, the higher the rank

—Topography; stepped foundations require a higher rank

—Climate; the deeper the frost line, the higher the rank

CK MASONRY BLOCKS (SF)

A masonry block foundation for a building that has bearing walls supporting the upper floor(s) and roof structure. The cost includes excavation, trenching, forming, reinforcing, concrete and backfill required for both perimeter and interior footings, and foundation.

Enter the square feet of floor area.

Rank is influenced by:

—Load supported; the greater the load, the higher the rank

—Size and shape; the higher the ratio of the perimeter to floor area, the higher the rank

—Topography; stepped foundations require a higher rank

—Climate; the deeper the frost line, the higher the rank

CL INSULATION (ADD; LF)

This is an added cost to the foundation for insulation. It is made of polystyrene beadboard.

Rank selection should consider that climate has an influence on the thickness and cost of the insulation used.

CP STANDARD BIN WITHOUT FLOOR (BU)

Size Range: 1,000 BU–35,000 BU

This component represents the average cost of utility-type storage bins found on farms and ranches. The cost includes a tank with door and manhole.

CPA CONCRETE FLOOR, STANDARD BIN (ADD; Diameter)

Size Range: 10 feet–40 feet in diameter

A concrete slab floor for a standard bin. (Use component CP for standard bins.)

CPB BUNKER SILO, TILT-UP (LF Length and LF Width)

Size Range: Width 20–80 LF

Horizontal aboveground storage facility constructed of tilt-up or precast concrete panels with precast supports. The cost includes a concrete floor.

CPC BUNKER SILO, POLES & BRACES (LF Length and LF Width)

Size Range: Width 20–80 LF

Horizontal aboveground storage facility constructed of tilt-up or precast concrete panels with wood poles and bracing supports. The cost includes a concrete floor.

CPD BUNKER SILO, WOOD (LF Length and LF Width)

Size Range: Width 20–80 LF

Horizontal aboveground storage facility constructed of plywood or tongue-and-groove walls with wood braces and supports. The cost includes a concrete floor.

CPE TRENCH SILO, TILT-UP (LF Length and Width)

Size Range: Width 20–80 LF

Horizontal belowground storage facility consisting of an earthen trench lined with concrete panels. The cost includes a concrete floor.

CPF TRENCH SILO, POLES & BRACES (LF Length and LF Width)

Size Range: Width 20–80 LF

Horizontal belowground storage facility consisting of an earthen trench with lined walls of plywood or tongue-and-groove wood. The cost includes a concrete floor.

CPG TRENCH SILO, WOOD (LF Length and LF Width)

Size Range: Width 20–80 LF

Horizontal belowground storage facility consisting of an earthen trench lined with a plastic sheet. Flooring is not included in the cost.

CPS	STEEL CANOPY (SF Area Covered) A rooflike structure projecting from a wall or supporting pillars. These canopies are typically found in service stations. The cost includes design, installation, light fixtures, roof cover, and supports.
CPT	CARPORT (SF Carport) Restrictions: Classes C, D, and S only A roofed shelter that may or may not be attached to the primary structure. The cost includes floor structure, roof support system (including posts and beams), and roof cover.
CPW	WOOD CANOPY (SF Area Covered) A rooflike structure projecting from a wall or supporting pillars. These canopies are typically found in service stations. The cost includes design, installation, light fixtures, roof cover, and supports.
CPX	CANOPY, CONCRETE DOUBLE "T" (SF Canopy) Restrictions: Models 171-x and 172-x A rooflike structure made of precast double "T" concrete sections that are supported by steel or concrete columns. The cost includes design, installation, light fixtures, roof cover, and supports.
CR	FEED TANK (BU) Size Range: 100 BU–6,000 BU A typical farm hopper. The cost includes a roof, manhole, ladder, steel structural supports, and concrete footings.
CRC	CORNCRIB, WIRE MESH ON WOOD SKELETON FRAME (SF Area) Corncrib buildings are for the dry storage of corn on the cob. The cost includes a concrete slab or wood plank floor.
CRD	CORNCRIB, SPACED BOARDS ON WOOD SKELETON FRAME (SF Area) Corncrib buildings are for the dry storage of corn on the cob. The cost includes concrete slab or wood plank floor.

CRE WOOD CRIB—METAL CLAD ELEVATOR (BU)

Size Range: 5,000 BU–500,000 BU

Cost includes head house (working house), tunnel, conveyor gallery, and storage tanks or bins.

Special foundation work such as pilings or extremely large concrete pads, is not included in the cost. Cost does not include equipment, separate warehouse, or office structures.

Enter the total licensed bushel capacity of the elevator.

Use component CRF for additional annex storage.

CRF WOOD CRIB—METAL CLAD ANNEX (BU)

Size Range: 25,000 BU–500,000 BU

This component should be used for elevators when there is an exposed leg system and no head house. It may also be used for additional detached storage that utilizes the original elevator as well as its basic machinery. If the annex has a head house, it should be priced as an elevator (use component CRE), using the total capacity of both the elevator and the annex.

Special foundation work, such as pilings or extremely large concrete pads, is not included in the cost.

Enter the total licensed bushel capacity of the annex.

CRG CONCRETE SLIP FORM ELEVATOR (BU)

Size Range: 50,000 BU–1,500,000 BU

This silo elevator is constructed of concrete with the use of a slip form. The cost includes a head house (working house), tunnel, conveyor gallery, and storage tanks or bins.

Special foundation work, such as pilings or extremely large concrete pads, is not included in the cost. Cost does not include equipment, separate warehouse, or office structures. Use component CRH for additional annex storage.

Enter the total licensed bushel capacity of the elevator.

RH CONCRETE SLIP FORM ANNEX (BU)

Size Range: 50,000 BU–1,500,000 BU

This type of annex is made of concrete and constructed with a slip form. This component should be used for elevators when there is an exposed leg system and no head house. It may also be used for additional detached storage that utilizes the original elevator as well as its basic machinery. If the annex has a head house, it should be priced as an elevator (use component CRG), using the total capacity of both the elevator and the annex. Special foundation work, such as pilings or extremely large concrete pads, is not included in the cost.

Enter the total licensed bushel capacity of the annex.

CRI BOLTED STEEL TANK (BU)

Capacity Range: 10,000–300,000 BU

Steel tanks used to store grain in a grain storage complex. The cost includes foundation and floor.

Special foundation work, such as pilings or extremely large concrete pads, is not included in the cost.

CRJ CORRUGATED METAL BIN (BU)

Capacity Range: 10,000–500,000 BU

Steel tanks used to store grain in a grain storage complex. The cost includes foundation and floor.

Special foundation work, such as pilings or extremely large concrete pads, is not included in the cost.

CRK HORIZONTAL STORAGE, WOOD (BU)

Capacity Range: 25,000 BU–1,500,000 BU

Heavy structural buildings used for horizontal or flat storage of grain.

Cost does not include loading or unloading systems.

CRL HORIZONTAL STORAGE, STEEL (BU)

Size Range: 25,000 BU–1,500,000 BU

Heavy structural buildings used for horizontal or flat storage of grain.

Cost does not include loading or unloading systems.

CRM ELEVATOR MACHINERY AND EQUIPMENT (BU)

Size Range: 5,000 BU–1,500,000 BU

The cost for machinery and equipment depends on the exact job that the elevator performs.

Rank 1 or 2 should be used for storage only.
Ranks 3 and 4 include processing equipment and computerized terminal facilities.

The flow capacity and age of the equipment should also be taken into consideration when selecting rank.

CRT STEEL FLOOR, STANDARD BIN (ADD; Feet Diameter)

Size Range: 10 feet–40 feet in diameter

A steel floor for a standard bin (use component CP for standard bins).

CRU VENTILATED FLOOR, STANDARD BIN (ADD; Feet Diameter)

Size Range: 10 feet–40 feet in diameter

A ventilated steel floor for a standard bin (use component CP for standard bins). The cost includes floor, auger tube, and steel columns and beam supports for plenum assembly.

CRV FAN AND HEAT, STANDARD BIN (ADD; Feet Diameter)

Size Range: 10 feet–40 feet in diameter

A fan and heater for a standard bin. (Use component CP for standard bins.)

CRW CONCRETE JUMP FORM ELEVATOR (BU)

Size Range: 50,000–1,500,000 BU

Grain elevator complex where concrete storage units are built utilizing jump form construction. Cost includes complete head house (working house), tunnel, conveyor gallery, and storage tanks or bins. Special foundation work, such as pilings or extremely large concrete pads, is not included in the cost.

Cost does not include equipment, separate warehouses, or office structures.

Enter the total licensed bushel capacity of the elevator.

Use component CRX for additional annex storage.

CRX CONCRETE JUMP FORM ANNEX (BU)

Size Range: 50,000–1,500,000 BU

This type of annex is made of concrete and constructed with a jump form. This component should be used for elevators when there is an exposed leg system and no head house. It may also be used for additional detached storage that utilizes the original elevator as well as its basic machinery. If the annex has a head house, it should be priced as an elevator (use component CRG), using the total capacity of both the elevator and the annex. Special foundation work, such as pilings or extremely large concrete pads, is not included in the cost.

Enter the total licensed bushel capacity of the annex.

CS CONCRETE SILO (BU)

Size Range: 2,000 BU–60,000 BU

Used to store corn or grass silage, haylage, high-moisture grain, and other fermented feed. The cost includes a ladder, chute, and dome roof.

CT BRICK MASONRY SILO (BU)

Size Range: 2,000 BU–60,000 BU

Used to store corn or grass silage, haylage, high-moisture grain, and other fermented feed. The cost includes a ladder, chute, and dome roof.

CU REINFORCED CONCRETE SILO (BU)

Size Range: 2,000 BU–60,000 BU

Used to store corn or grass silage, haylage, high-moisture grain, and other fermented feed. The cost includes a ladder, chute, and dome roof.

CV CONCRETE BLOCK SILO (BU)

Size Range: 2,000 BU–60,000 BU

Used to store corn or grass silage, haylage, high-moisture grain, and other fermented feed. The cost includes a ladder, chute, and dome roof.

CW STEEL SILO (BU)

Size Range: 2,000 BU–60,000 BU

Used to store corn or grass silage, haylage, higher-moisture grain, and other fermented feed. The cost includes a ladder, chute, and dome roof.

CX GLASS-LINED STEEL SILO (BU)

Size Range: 2,000 BU–60,000 BU

Used to store corn or grass silage, haylage, high-moisture grain, and other fermented feed. The cost includes a ladder, chute, and dome roof.

CY WOOD SILO (BU)

Size Range: 2,000 BU–60,000 BU

Used to store corn or grass silage, haylage, high-moisture grain, and other fermented feed. The cost includes a ladder, chute, and dome roof.

D RUBBLE MASONRY WALL (SF Basement Wall Area)

Thickness Range: 6"–36" Required in miscellaneous field.

A basement masonry wall constructed using some type of fieldstone that usually has various shapes and is built without coursing or regularity. Costs vary depending on the availability and type of local stone used.

Cost does not include waterproofing or insulation.

The cost is the same as basement wall component F.

The quality of the interior finish and the quantity and quality of openings should be considered when selecting a rank.

DB FLOOR SUPPORTS (SF)

Primarily for the support of a raised floor with a crawl space or basement. This component is used with buildings having primarily load-bearing exterior walls. The cost includes girders, posts, and poles or jacks required to support the floor.

Size and spacing of the supports should be the major consideration in selecting the cost rank.

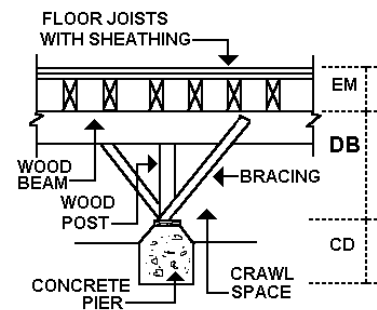
**DBA FLOOR SUPPORTS, MASONRY (SF)**

Restrictions: Classes C, D, and S only
Residential and Farm Models only

A masonry column for the support of a raised floor with a crawl space or basement beneath it. This component is used with buildings having primarily load-bearing exterior walls. Cost includes the girders.

Size and spacing of the supports should be the major consideration in selecting the cost rank.

- DBU DOCK BUMPERS, HORIZONTAL (LF)**
- DBV DOCK BUMPERS, VERTICAL (LF)**
- DBW DOCK LEVELERS, MECHANICAL (EA)**
- DBX DOCK LEVELERS, HYDRAULIC (EA)**
- DBY DOCK LEVELERS, EDGE OF DOCK (EA)**

The above features are found in warehouses, industrials, lofts, and garages.

DC CONCRETE, REINFORCED—CLASS B (SF)

Reinforced concrete columns and beams that support the weight of the floor and roof in a fully framed building. The columns and beams may either be precast or formed and poured on site.

This type of construction is characteristic of Class B buildings if the floors and roof are also of fire-resistant material. In partially framed buildings, a proportional cost is required.

Size and spacing of the members should be the major consideration in selecting the cost rank.

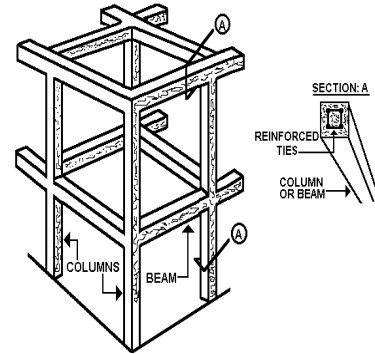

DF WOOD FRAME MEMBERS (LF)

Priced on a linear foot of supporting member, accounts for either glue laminated or timber-type beam and wood columns supporting the beam.

Use the following table to select a rank:

SIZE	COST RANK		SIZE	COST RANK	
	TIMBER	GLU-LAM		TIMBER	GLU-LAM
4" x 4"	1.0	1.7	10" x 10"	2.4	2.6
4" x 8"	1.5	2.0	10" x 20"	2.9	3.0
4" x 12"	1.8	2.2	10" x 30"	3.3	3.2
4" x 16"	2.2	2.4	12" x 12"	2.7	2.8
6" x 6"	1.6	2.1	12" x 24"	3.2	3.2
6" x 10"	2.0	2.3	12" x 36"	3.5	3.5
6" x 14"	2.2	2.5	14" x 14"	2.9	3.0
6" x 20"	2.5	2.7	14" x 28"	3.4	3.4
8" x 8"	2.0	2.4	14" x 42"	3.8	3.7
8" x 12"	2.3	2.6	16" x 16"	3.1	3.2
8" x 16"	2.6	2.7	16" x 32"	3.7	3.6
8" x 24"	2.9	2.9	20" x 26"	4.0	3.9

DFA STAINED GLASS WINDOW (SF Area)

Art glass with detailed figures and large decorative background areas. The smallest dimension of the dominant pieces is 4 inches or greater.

DFB STAINED GLASS WINDOW (SF Area)

Art glass with detailed figures and large decorative background areas. The smallest dimension of the dominant pieces is between 2 and 4 inches.

DFC STAINED GLASS WINDOW (SF Area)

Art glass with detailed figures and large decorative background areas. The smallest dimension of the dominant pieces is less than 2 inches.

DG STEEL FRAME MEMBERS (LF)

Structural steel supporting members.

Use the following tables to select a rank:

H BEAMS			
SIZE	RANK	SIZE	RANK
4" x 4"	1.9	12" x 12.00"	4.0
5" x 5"	2.3	14" x 14.50"	4.2
6" x 6"	2.6	18" x 11.75"	4.3
8" x 8"	3.1	24" x 14.00"	4.7
10" x 10"	3.6	30" x 15.00"	5.1

I BEAMS			
SIZE	RANK	SIZE	RANK
3"	1.0	12"	3.1
4"	1.4	14"	3.3
6"	2.1	16"	3.5
8"	2.5	20"	3.7
10"	2.8	24"	4.0

DH LAMINATED BENTS AND ARCHES (SF)

A fully framed building where glue laminated bents and arches are used to support roof loads over large open areas. The bents and arches are usually constructed at a central plant and transported to the site and erected. Typically, laminations are thin enough to bend easily (1–2 inches) to the desired shape (e.g., arch or A-frame). This component is used primarily for large open-shell type occupancies such as churches, auditoriums, and gymnasiums.

A percentage of the floor area should be entered for partially framed buildings.

Size and spacing of the members should be the major consideration in selecting the cost rank.

DI STEEL, FIREPROOFED (SF)

A full frame built with fire-resistant structural steel columns and beams. The steel is made fire-resistant through the application of some type of noncombustible material. This type of frame is found primarily in high-rise structures and is characteristic of Class A buildings.

A percentage of the floor area should be entered for partially framed buildings.

The size and spacing of the frame members should be considered when selecting a rank.

DJ STEEL, NOT FIREPROOFED (SF)

A full frame where frame columns and beams totally support the building and are made of structural steel. This type of frame is characteristically found in low-rise commercial construction, typically Class C and D buildings, and is basically non-fire-resistant.

A percentage of the floor area should be entered for partially framed buildings.

The size and spacing of the frame members should be considered when selecting a rank.

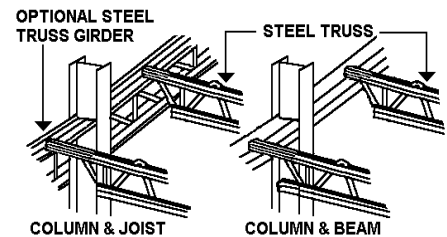

DK WOOD POSTS AND BEAMS (SF)

A full frame composed of wood beam and post members, which is most commonly found in Class D, but may also be encountered with Class C buildings.

A percentage of the floor area should be entered for partially framed buildings.

Size and spacing of the members should be a major consideration in selecting the cost rank.

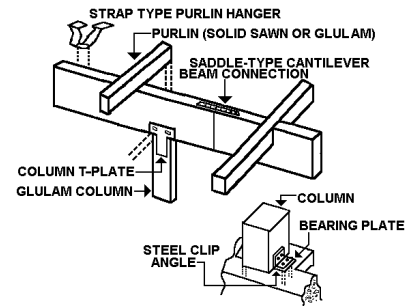
**DL WOOD, MILL TYPE (SF)**

A full frame usually constructed of wood timbers much thicker than typical joists required for structural support of the building. This type of frame is most commonly found in older Class C structures to support heavy loads.

A percentage of the floor area should be entered for partially framed buildings.

Size and spacing of the members should be the major consideration when selecting the cost rank.

DLR LOADING DOCK WITH ROOF (SF)

This complete dock is designed primarily for loading and unloading of materials. Higher cost structures have steel or concrete piers, heavy slab, and steel bumpers. Lower cost structures have light wood piers and light wood floors. Roof systems may include finished soffits and some lighting depending on the cost rank.

DLW LOADING DOCK WITHOUT ROOF (SF)

This complete dock is designed primarily for loading and unloading of materials. Higher cost structures have steel or concrete piers, heavy slab, and steel bumpers. Lower cost structures have light wood piers and light wood floors.

DLX LOADING WELL, SINGLE (EA)

A loading well is designed to enable a tractor-trailer rig to back into a ground-level loading platform. The length is 75 feet, tapering down from ground level to a depth of approximately 3 1/2 to 4 feet. Cost includes excavation, backfill, foundation, reinforced concrete walls, and concrete paving.

Rank is influenced by length and depth.

Use component DLY for each additional well.

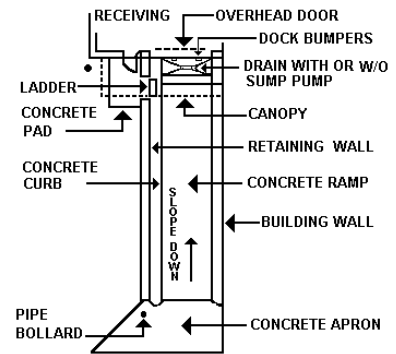

DLY LOADING WELL, ADDITIONAL (ADD; EA)

Use this component for the added cost of each additional loading well above one. See component DLX.

DM REINFORCED CONCRETE MEMBERS (LF)

Partially framed building with concrete columns and beams. Use this component when the concrete frame members are priced on linear feet of column and beam rather than square feet of floor area.

Use the following table to select a rank:

CONCRETE COLUMNS			
SIZE	RANK	SIZE	RANK
12"	2.4	24"	3.3
14"	2.6	28"	3.5
16"	2.7	32"	3.7
18"	2.9	36"	3.9
20"	3.1	—	—

CONCRETE COLUMNS			
SIZE	RANK	SIZE	RANK
4" x 6"	1.0	10" x 18"	2.5
6" x 8"	1.6	12" x 16"	2.6
8" x 10"	2.0	12" x 20"	2.9
10" x 12"	2.3	12" x 24"	3.0

DNA STEEL, LIGHT PRE-ENGINEERED—CLASS S (SF)

Pre-engineered Class S frames are typically light, open steel skeleton members consisting of open web, post and beam, or rigid bent configurations. The frame is basically non-fire-resistant. The cost includes columns, beams, and ties.

A percentage of the floor area should be entered for partially framed buildings.

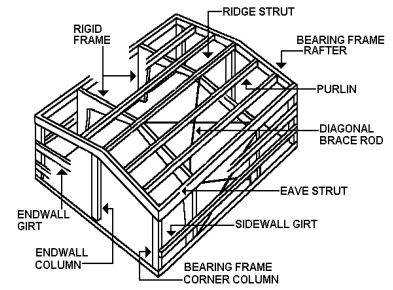

DO PIPE COLUMNS (LF)

Steel pipe columns that are used for the support of the beams. Cost includes all plates, welding, and ancillary items. The columns may or may not be concrete-filled, depending on the design characteristics of the building.

Use the following table to select a rank:

PIPE COLUMNS		
SIZE	ROUND	SQUARE
3"	1.4	2.0
4"	2.3	2.6
6"	3.3	3.7

DOF DOCK-HEIGHT FLOOR (ADD; SF)

Use this component to adjust for the increased cost related to dock-height floors. This cost is in addition to the base cost of the first floor. Cost includes stem wall and fill.

Restrictions: Stem wall height 2–4 feet

DOS SHIPPING DOCK (SF Area)

An area for loading and unloading materials. Cost includes some enclosed office space, adequate rest rooms and industrial-type lighting. There may also be enclosed storage.

DP WOOD, LIGHT POLE TYPE (SF)

A pole frame construction used in Class D buildings. It is a full frame composed of light wood posts and prefabricated trusses. In partially framed buildings, a proportional cost is required.

Size and spacing of the members should be the major consideration in selecting the cost rank.

DQ WOOD FRAME MEMBERS (LF)

Used in partially framed residential type construction when the wood frame members are priced on linear feet of column and beam rather than square feet of floor area.

Rank 1 for 4" x 4" members.
Rank 4 for 6" x 14" members.

Use component DF for larger commercial applications.

DR STEEL FRAME MEMBERS (LF)

Used in partially framed residential type construction when the structural steel frame members are priced by linear feet of column and beam rather than square feet of floor area.

Rank 1 for 3" I-beam.
Rank 4 for 10" I-beam.

Use component DG for larger commercial applications.

DS CONCRETE FRAME MEMBERS (LF)

Used in partially framed residential type construction when the concrete frame members are priced by linear feet of column and beam rather than square feet of floor area.

Rank 1 for 4" x 6" members.
Rank 4 for 10" x 12" members.

Use component DM for larger commercial applications.

DT PIPE COLUMNS (LF)

Used in partially framed residential type construction when the pipe columns are priced by linear feet of column rather than square feet of floor area.

Rank 1 for 3" diameter pipe.
Rank 4 for 6" diameter pipe.

Use component DO for larger commercial applications.

DTB DRIVE-IN THEATER, CAR SPEAKER POST (EA)

Support post and junction box for car speakers found at a drive-in theater.

DTC DRIVE-IN THEATER, LIGHTING, DIRECTIONAL (EA)

Lighted directional signs in a drive-in theater.

DTE DRIVE-IN THEATER, LIGHTING, GROUND LEVEL (EA)

Ground-level lighting at entry, exit, and ramps in a drive-in theater.

DTG DRIVE-IN THEATER, RAMP, PAVED (EA Car Space)

Paved automobile ramps found at a drive-in theater. These ramps are used to tilt the front of cars towards the screen. The cost includes grading and prorated drive costs.

Rank 1 has narrow drives with a minimum ramp slope.
Rank 4 has wide drives with a well-designed ramp slope.

DTJ DRIVE-IN THEATER, SCREEN, CONCRETE FRAME (SF Screen Area)

Drive-in theater screen consisting of tilt-up concrete panel on concrete frame with steel framed enclosure.

Rank is influenced by the thickness of the panel.

DTK DRIVE-IN THEATER, SCREEN, STEEL FRAME (SF Screen Area)

Drive-in theater screen supported by reinforced concrete footings.

Rank 1 for plain, open exposed frame.
Rank 4 for enclosed ornate frame with a storage area at the base.

DTL DRIVE-IN THEATER, SCREEN, WOOD FRAME, BRACED (SF Screen Area)

Drive-in theater screen constructed on a wood frame with timber bracing, supported by poles set in concrete.

DTM DRIVE-IN THEATER, SCREEN, WOOD FRAME, GUYED (SF Screen Area)

Drive-in theater screen constructed on a wood frame with poles and guy wires.

DTN DRIVE-IN THEATER, SCREEN, WOOD FRAME, TIMBERS

(SF Screen Area)

Drive-in theater screen constructed on a wood frame, supported with timbers set in concrete footings.

Rank 1 is plain open exposed frame.

Rank 4 is enclosed ornate frame with a storage area at the base.

DTT TICKET BOOTH (EA)

Restrictions: Drive-in theaters only

Individual ticket booths at a drive-in theater.

Cash registers are not included in the cost.

DU WOOD "A"-FRAME (SF)

A full frame where wooden structural members totally support the building in an "A" configuration. The cost includes ties.

Rank is influenced by size, spacing, and quality of the wood members.

DV STEEL COLUMNS, WOOD BEAMS (SF)

A full or partial frame where steel columns and wood beams support the building. The cost includes plates, saddles, and ancillary items.

Rank 1 for pipe columns and glu-lam beams.

Use a high rank for structural steel and heavy wood timbers.

Use the same cost rank as the building if:

Columns are square, 5" up to 8".

Columns are round.

Architectural design conceals the column.

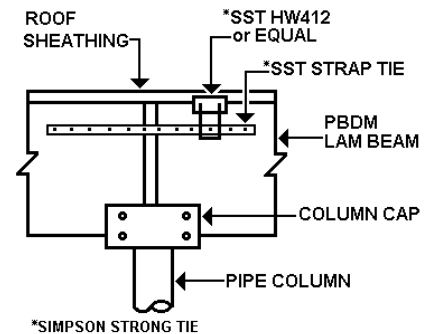

E WATERPROOFING (ADD; SF Basement Wall Area)

The type of waterproofing most commonly applied over basement walls is a bituminous membrane.

In some instances, chemical sealants are used to seal pores and cracks over masonry walls.

This component is used with one of the following components:

- A Brick Masonry Wall
- B Concrete Block Wall
- C Concrete Reinforced Wall
- D Rubble Masonry Wall
- G Wood Treated Wall

EA ASPHALT ON GROUND (SF)

A paving material that is most frequently found in the industrial warehouse or agricultural occupancies. The thickness of the asphalt material varies depending on the structural requirements of the building itself. The material used is generally of an asphalt—concrete mixture applied over a base. The base mixture is usually gravel.

Rank is influenced by the thickness of the floor.

EAA COMPACTED EARTH (SF)

Restrictions: Classes C, D, and S only
Farm models only

Flat compacted earth that has been graded to serve as the finished floor of a farm building.

EAB GRAVEL (SF)

Restrictions: Classes C, D, and S only
Farm models only

Flat compacted gravel that has been graded to serve as the finished floor of a farm building.

Rank is influenced by the depth of the gravel.

EAC CONCRETE, PRECAST JOISTS, WOOD SHEATHING (SF)

Floor system consisting of precast concrete joists and wood sheathing.
Cost does not include floor cover.

Size and spacing of the members should be the major consideration in selecting the cost rank.

EAD STEEL JOISTS, OPEN METAL GRATING (SF)

Restrictions: Garage, Industrial, and Farm models only

Structural steel floor members (joists) that support an open metal grating deck. The cost includes ancillary items.

Size and spacing of the members should be the major consideration in selecting the cost rank.

EAE SUPER FLAT SLAB (ADD; SF)

Restrictions: Hangars, Docks, etc.

Use this component to adjust for the cost of additional concrete finishing used to create an extremely level and smooth surface on a concrete slab (components EC and ED). This type of finish is used in industrial applications.

Rank 1 represents normal labor with special care.
Rank 4 represents mechanical grinding and finishing.

EB CONCRETE ON GROUND (SF)

A concrete slab floor that is poured directly onto the ground. The thickness of the slab varies with the structure's occupancy. The cost includes reinforcing (either mesh or reinforcing bars).

The cost does not include a vapor barrier (EP) or a floor cover.

EC CONCRETE, ELEVATED SLAB (SF)

Concrete slab floor system formed and poured in place above grade or basement level. Requires a considerable amount of shoring material with plywood as the form for the concrete slab system. System is reinforced with bars.

Cost does not include floor cover.

The size and spacing of the joists and the thickness of the deck should be considered when selecting a rank.

ED CONCRETE, LIFT SLAB (SF)

Concrete slab formed and poured at a lower level and mechanically lifted into place.

Cost does not include floor cover.

EE CONCRETE, PAN (SF)

A concrete slab system that is poured in place above grade level. It is most commonly found in high-rise construction. The system requires shoring material and metal pan forming material system. Because of the forming technique utilized, the slab is poured integral with the beams making one system of slab and beams. Reinforcing is included in costs.

Cost does not include floor cover.

The size and spacing of the joists and the thickness of the deck should be considered when selecting a rank.

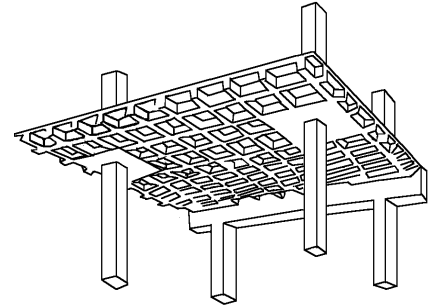
**EF CONCRETE, PRECAST JOISTS AND SLAB (SF)**

Supporting members (joists) and slab are generally prefabricated off site and then transported to the site and lifted into place with the use of a crane. This system may be poured at the site, although not in place, and then put in place after the concrete material has cured.

Cost does not include floor cover.

The size and spacing of the joists and the thickness of the deck should be considered when selecting a rank.

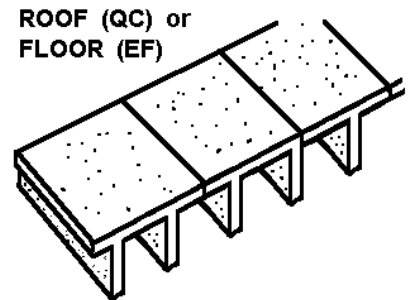
**EGA ASPHALT WALK (SF Walk Area)**

Restrictions: Commercial Greenhouse model only

Asphalt paved walk area between plant tables in a commercial greenhouse.

The thickness of asphalt should be considered when selecting a rank.

EGB GRAVEL WALK (SF Walk Area)

Restrictions: Commercial Greenhouse model only

Graded gravel walk area between plant tables in a commercial greenhouse.

The depth of the gravel should be considered when selecting a rank.

EGC CONCRETE WALK (SF Walk Area)

Restrictions: Commercial Greenhouse model only

Concrete walk area between plant tables in a commercial greenhouse.

The depth of the concrete should be considered when selecting a rank.

EH STEEL JOISTS, CORRUGATED DECK AND CONCRETE (SF)

Structural steel joists with steel decking used as the floor sheathing. On top of the steel decking is a poured concrete slab floor.

Cost does not include floor cover.

The size and spacing of the joists and the thickness of the deck should be considered when selecting a rank.

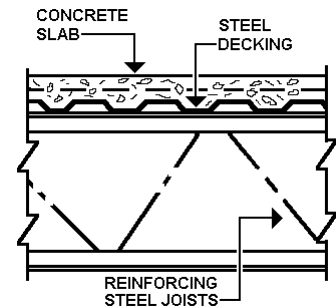
**EI STEEL JOISTS, CELLULAR DECK AND CONCRETE (SF)**

Structural steel floor members (joists) that support a cellular deck. The deck is made of concrete poured over two layers of sheet metal that have been welded together to form the cells. Cells formed in the system serve as raceways for electrical conduit and other utilities.

Cost does not include floor cover.

The size and spacing of the joists and the thickness of the deck should be considered when selecting a rank.

EJ STEEL JOISTS, CONCRETE SLAB (SF)

Reinforced concrete slab poured over the structural steel joists supporting system.

Cost does not include floor cover.

The size and spacing of the joists and the thickness of the deck should be considered when selecting a rank.

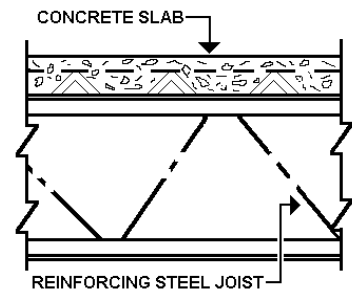
**EK STEEL JOISTS, PRECAST PLANK (SF)**

Precast concrete plank poured off site and transported to the site, or poured at the site but not in place. The plank is placed over a structural steel floor frame. Cost does not include floor cover.

The size and spacing of the joists and the thickness of the deck should be considered when selecting a rank.

EL STEEL JOISTS, WOOD SHEATHING (SF)

A supporting floor system made of structural steel members (joists) that are covered with wood sheathing. Type of sheathing used and spacing of the joists depend on design characteristics of the building.

Cost does not include floor cover.

The size and spacing of the joists and the thickness of the deck should be considered when selecting a rank.

EM WOOD JOISTS AND SHEATHING (SF)

Composed of wood joists and wood sheathing. The size of the joists varies with the design characteristics of the building. Sheathing material used is plywood or tongue-and-groove wood material or particle board. The cost includes all blocking material used to give the structure strength.

The cost does not include floor cover.

The size and spacing of the joists and the thickness of the deck should be considered when selecting a rank.

EN WOOD JOISTS, BRIDGING ONLY (SF)

Wood joists without sheathing. Bridging or blocking is included to give added strength to the wood joists. This is normally found when finished wood floor covering is placed directly on the joists.

Cost does not include finished floor cover.

EO INSULATION (ADD; SF)

A material used to obstruct the passage of heat or cold through the floor. The insulation may be fiberglass batt material, loose mineral wool, or insulating board.

Rank selection should consider that climate has an influence on the thickness and therefore the cost of the insulation used.

EP VAPOR BARRIER (ADD; SF)

Any combination of material designed to stop the passage of moisture. Plastic sheets or treated papers and asphalt are used for membranes with sand fill.

Rank is influenced by type of materials and installation. Low ranks are minimum polyethylene vapor barrier; higher ranks are built-up membranes with good sand fill.

EQ STEPPED INTERIOR BALCONY, CONCRETE (SF Balcony Area)

A stepped platform for seating above ground level on the interior of the building. The balcony has a concrete floor and supporting system.

The cost does not include floor cover or soffit finish.

ER INTERIOR BALCONY, CONCRETE AND STEEL (SF Balcony Area)

A stepped platform for seating above ground level on the interior of the building. The balcony has a concrete floor supported by steel members.

The cost does not include floor cover or soffit finish.

ES INTERIOR BALCONY, WOOD (SF Balcony Area)

A stepped platform for seating above ground level on the interior of the building. The floor, joists and sheathing are made of wood.

The cost does not include floor cover or soffit finish.

ESDM - STADIUM SEATING FLOOR STRUCTURE (ADD; SFF)

Use this component for the **added** cost of stadium seating floor structure in a movie theater. For theaters with all stadium seating, enter the square footage of the **entire** improvement. The cost has been adjusted to allow for non-stadium floor structure in lobbies, restrooms, hallways, etc. For theaters with mixed stadium and non-stadium seating, use the percentage of stadium seating to total seating. Use this component in addition to the regular floor structure component. (For example, EB - concrete on ground) The cost does not include seats.

ET INTERIOR BALCONY, WOOD & STEEL (SF Balcony Area)

A stepped platform for seating above ground level on the interior of the building. The balcony has a wood floor system, joists, sheathing, and steel supporting members.

Cost does not include floor cover or soffit finish.

EU SHEATHING OVER 1 INCH (ADD; SF)

Thickness Range: 1"–6" Required in miscellaneous field.

Use this component to adjust for the increased cost related to each additional inch of thickness above one inch of floor sheathing. This type of floor structure is typical of old mill-type buildings.

EV CONCRETE, PLANK ON BEARING WALL (SF)

Precast concrete plank floor resting on bearing walls.

Cost does not include floor cover.

EW FOAMED CONCRETE SUBFLOOR (ADD; SF)

Very lightweight cellular concrete, about 1 5/8" thick, in which bubbles of air are entrapped either by chemical or mechanical means. Normally applied over wood, it acts as a sound insulator and base for a finished floor cover.

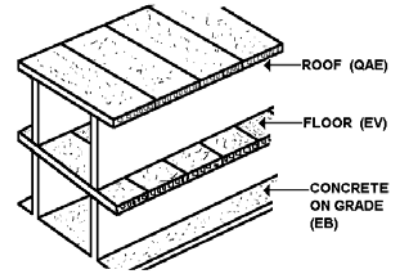
**EWA CAR WASH, ASPHALT (SF)**

Restrictions: Model 175–x only

Asphalt floor in a self-service car wash. The cost includes drains.

The thickness of the floor and the durability of finish should be considered when selecting a rank.

EWB CAR WASH, CONCRETE (SF)

Restrictions: Model 175–x only

Concrete floor in a self-serve car wash. The cost includes drains.

The thickness of the slab and the slab finish should be considered when selecting a rank.

EX CONCRETE SLAB (SF)

Restrictions: Models 171–x and 172–x

Concrete floor for service station. The cost includes perimeter grade beam, vapor barrier, and gravel base.

The floor cover is not included in the cost.

The thickness of the slab and the slab finish should be considered when selecting a rank.

EY WOOD FLOOR STRUCTURE (SF)

Restrictions: Models 171-x and 172-x only

Elevated wood floor in a service station. The cost includes joists, posts, beams and sheathing.

EZA SLOTTED FLOORS, CONCRETE (SF)

Restrictions: Classes C, D, and S only
Farm models only

Concrete floor with slots between members designed so that livestock droppings can pass through to a holding area at a lower level. The cost includes fastening ties.

EZB SLOTTED FLOORS, METAL (SF)

Restrictions: Classes C, D, and S only
Farm models only

Metal floor with slots between members designed so that livestock droppings can pass through to a holding area at a lower level. The cost includes fastening ties.

EZC SLOTTED FLOORS, WOOD (SF)

Restrictions: Classes C, D, and S only
Farm models only

Wood floor with slots between members designed so that livestock droppings can pass through to a holding area at a lower level. The cost includes fasteners.

EZD MANURE GUTTER (SF)

Restrictions: Farm models only

A concrete trenchlike trough in a livestock building used to pass manure to a holding area. The cost includes excavation and forming.

Cost does not include metal grate covering. Use component FAG for grating.

F STONE MASONRY WALL (SF Basement Wall Area)

Thickness Range: 4"–36" Required in miscellaneous field.

Stone masonry placed into a solid wall or cavity wall that has been reinforced and grout-filled. Wall thickness varies depending on the structural requirements of the building, but generally is between 8 and 12 inches.

The cost does not include waterproofing or insulation.

The quality of the interior finish and the quantity and quality of openings should be considered when selecting a rank.

FA ASPHALT TILE (SF)

A resilient floor cover attached to a wood or concrete floor system with mastic or tile cement. Typical tile size is 9" x 9". Commonly found in darker color patterns (lighter color patterns are usually composed of a resin base). Asphalt tile is generally the least expensive type of resilient flooring.

Rank is influenced by:

—Color: products with embossed colors are low rank, while products with solid coloring throughout are high rank.

—Pattern: marbled and plain patterns are low rank, with simulated brick and stone patterns at high rank.

—Thickness: sizes vary from 1/8" T (low) to 3/8" T (high).

—Material grade: asphalt and vinyl composition tile materials (low to average) are less than solid vinyl and rubber tile materials (good to high).

—Underlayment: a higher ranking should be allowed for floor covers that are laid on underlayment that has been installed on wood, concrete, or metal subfloor.

—Coving–topset base: use a higher rank for coved perimeters and topset base molding.

FAB VINYL SHEET (SF)

Floor covering installed in sheets. It is used most often in heavy traffic areas and comes in varying thickness and patterns.

Rank is influenced by:

—Color: products with embossed colors are low rank, while products with solid coloring throughout are high rank.

—Pattern: marbled and plain patterns are low rank, with simulated brick and stone patterns at high rank.

—Thickness: sizes vary from 1/8" T (low) to 3/8" T (high).

—Material grade: asphalt and vinyl composition tile materials (low to average) are less than solid vinyl and rubber tile materials (good to high).

—Underlayment: a higher ranking should be allowed for floor covers laid on underlayment that has been installed on wood, concrete, or metal subfloor.

—Coving—topset base: use a higher rank for covered perimeters and topset base molding.

FAC VINYL TILE (SF)

A floor tile made of vinyl. Used most often in heavy traffic areas and comes in varying thickness and patterns.

Rank is influenced by:

—Color: products with embossed colors are low rank, while products with solid coloring throughout are high rank.

—Pattern: marbled and plain patterns are low rank, with simulated brick and stone patterns at high rank.

—Thickness: sizes vary from 1/8" T (low) to 3/8" T (high).

—Material grade: asphalt and vinyl composition tile materials (low to average) are less than solid vinyl and rubber tile materials (good to high).

—Underlayment: a higher ranking should be allowed for floor covers that are laid on underlayment that has been installed on wood, concrete, or metal subfloor.

—Coving—topset base: use a higher rank for covered perimeters and topset base molding.

FAD WOOD BLOCK, INDUSTRIAL (SF)

A durable floor finish made of treated solid wood blocks. The faces of the blocks are plain. They are generally set in asphalt mastic on a concrete slab. The cost includes the floor cover and finish only.

FAE WOOD OVER CONCRETE, SOFTWOOD (SF)

A softwood floor finish that is laid over sleepers and attached with mastic.

FAF WOOD OVER CONCRETE, HARDWOOD (SF)

A hardwood floor finish that is laid over sleepers and attached with mastic.

FAG METAL GRATING (SF)

Restrictions: Hangar and Farm models only

A floor cover system consisting of a metal grate with fasteners.

The cost does not include the subfloor.

Rank is influenced by gauge, type of metal, and supporting strength.

FAH VINYL COMPOSITION TILE (SF)

Floor tiles that are composed of vinyl resins and asbestos fillers. They come in a variety of colors and designs. Size and thickness of the tiles vary. Vinyl composition tile is also called vinyl asbestos tile.

The cost includes the adhesive.

FB BRICK, COMMON, IN MORTAR (SF)

Common red clay brick laid over the floor structure (usually concrete slab). The mortar acts as the adhesive bonding the brick to the floor system.

Rank is influenced by:

—Color: products with natural coloring (e.g., red brick and quarry tile) are low rank, while products with unusual natural or manmade color characteristics (e.g., green slate) are high rank.

—Installation Pattern: the common bond pattern is the least labor-intensive, with the herringbone pattern being more intensive, and the diamond pattern being the most intensive; ranking will increase as labor intensity increases.

FC BRICK, ACIDPROOF (SF)

Acidproof clay brick laid in an impervious membrane with acidproof cement on a concrete base. Usually found in industrial occupancies, the cover may also be in the form of acidproof brick tile that can be 1 to 1 3/8 inches thick, 4 inches wide, and 8 inches long. The concrete subfloor is not included in the cost.

Rank is influenced by:

—Color: products with natural coloring (e.g., red brick and quarry tile) are low rank, while products with unusual natural or manmade color characteristics (e.g., green slate) are high rank.

—Installation Pattern: the common bond pattern is the least labor-intensive, herringbone pattern is more intensive, and the diamond pattern is the most intensive; ranking increases as labor intensity increases.

FD BRICK PAVERS IN CONCRETE (SF)

Normally found in heavy traffic areas; thin brick or masonry tile is placed in the concrete before it cures (actually integral with the floor structure). It does not require mortar to be used as a bonding agent with the floor structure.

Rank is influenced by:

—Color: products with natural coloring (e.g., red brick and quarry tile) are low rank, while products with unusual natural or manmade color characteristics (e.g., green slate) are high rank.

—Installation Pattern: the common bond pattern is the least labor-intensive, herringbone pattern is more intensive, and the diamond pattern is the most intensive; ranking increases as labor intensity increases.

FE CARPET AND PAD (SF)

Nylon, acrylic, or wool carpeting with padding material installed beneath the carpet. Nylon carpets are typically least expensive; the types having a mesh woven backing being somewhat more expensive. Nylon is generally lighter weight, usually 15 to 22 ounces. Acrylic carpets appear very similar to wool, but are not as expensive and do not wear as well. Weights are between 36 and 42 ounces. Wool carpets are the most expensive and are usually 36 to 42 ounces in commercial grades.

Rank is influenced by:

—Color: natural colors are a lower rank than products with dyed colors.

—Pattern: solid patterns are a lower rank than products with intricate and varied weave patterns.

—Composition—Thickness: products are categorized by weight; 15–18 ounces being low grade and 30–33 ounces being high grade.

—Material Grade: synthetic materials are a lower rank than natural materials such as wool.

FF CONCRETE COLOR (SF)

A powder material that is mixed with a cement topping and applied when the slab floor structure is poured.

FG COMPUTER FLOOR ON STANCHIONS (SF)

A prefabricated floor system installed over pedestal grid supports to provide a raised or access floor. Both the support system and the panels have the structural strength to support the weight of a computer. The raised floor allows for the required building mechanical services to be located under the panels.

FGA STAINED GLASS WINDOW (SF Area)

Contemporary abstract art glass windows constructed with faceted glass 1 inch or less in thickness and cast in epoxy. The smallest dimension of the dominant pieces is 4 inches or greater.

FGB STAINED GLASS WINDOW (SF Area)

Contemporary abstract windows constructed with faceted glass 1 inch or less in thickness and cast in epoxy. The smallest dimension of the dominant pieces is between 2 and 4 inches.

FGC STAINED GLASS WINDOW (SF Area)

Contemporary abstract windows constructed with faceted glass 1 inch or less in thickness and cast in epoxy. The smallest dimension of the dominant pieces is less than 2 inches.

FGD STAINED GLASS WINDOW (SF Area)

Art glass windows with figures and scenes constructed of faceted glass 1 inch or less in thickness, and cast in epoxy. The smallest dimension of the dominant pieces is 4 inches or greater.

FGE STAINED GLASS WINDOW (SF Area)

Art glass window with figures and scenes constructed of faceted glass 1 inch or less in thickness, and cast in epoxy. The smallest dimension of the dominant pieces is between 2 and 4 inches.

FGF STAINED GLASS WINDOW (SF Area)

Art glass window with figures and scenes constructed of faceted glass 1 inch or less in thickness and cast in epoxy. The smallest dimension of the dominant pieces is less than 2 inches.

FGG STAINED GLASS WINDOW (SF Area)

Contemporary abstract art glass windows constructed with faceted glass 1 1/2 inches thick and bound in concrete. The smallest dimension of the dominant pieces is 4 inches or greater.

FGH STAINED GLASS WINDOW (SF Area)

Contemporary abstract art glass windows constructed with faceted glass that is 1 1/2 inches thick and bound in concrete. The smallest dimension of the dominant pieces is between 2 and 4 inches.

FGJ STAINED GLASS WINDOW (SF Area)

Contemporary abstract art glass windows constructed with faceted glass that is 1 1/2 inches thick and bound in concrete. The smallest dimension of the dominant pieces is less than 2 inches.

FGK STAINED GLASS WINDOW (SF Area)

Windows with figures and scenes constructed with faceted glass, which is 1 1/2 inches thick and bound in concrete. The smallest dimension of the dominant pieces is 4 inches or greater.

FGL STAINED GLASS WINDOW (SF Area)

Art glass windows with figures and scenes constructed with faceted glass that is 1 1/2 inches thick and bound in concrete. The smallest dimension of the dominant pieces is between 2 and 4 inches.

FGM STAINED GLASS WINDOW (SF Area)

Art glass windows with figures and scenes constructed with faceted glass that is 1 1/2 inches thick and bound in concrete. The smallest dimension of the dominant pieces is less than 2 inches.

FH CORK (SF)

A floor covering of pure cork shavings, compressed and baked in molds. It is typically found in high traffic occupancies (offices, hospitals, schools). Tiles vary in size from 6" x 12" to 12" x 12" and in thickness from 1/8" to 5/16". The edges may be beveled or unbeveled. The cork can be laid over wood subfloor with a felt lining or over a concrete slab without felt. Once laid, it is usually sanded, filled, and finished. The finish can be either a flat or glossy cork tile finish.

FI DIATO (SF)

A dense, stonelike, lightweight cellular cement composed of magnesium oxide, fillers, and aggregate floor cover. It is trowel-applied approximately one-half inch thick, generally over slab or wood floors. It provides a durable, easily cleanable surface, and may be found in a number of colors, textures, and surface designs.

FJ SEAMLESS PLASTIC, THIN-COAT (SF)

Either a urethane or neoprene coating applied over a floor surface with a thickness of 1/32 to 1/16 of an inch.

FK SEAMLESS PLASTIC, TROWELED (SF)

Either a urethane or neoprene coating, applied over a floor surface with a thickness of 1/8 to 3/8 of an inch.

Coloring, pattern, material grade, thickness, and any accompanying coving or underlayment should be considered when selecting a rank.

FL FLAGSTONE (SF)

Sandstone or shale split into slabs that are flat with irregular shapes and a thickness between 1 and 4 inches. Used for walks and high traffic areas. Mortar is used as the bonding material when flagstone is applied over concrete slab floor systems.

Rank is influenced by:

—Color: products with natural coloring (e.g., red brick and quarry tile) are low rank. Products with unusual natural or manmade color characteristics are high rank.

—Installation Pattern: the common bond pattern is the least labor-intensive, the herringbone pattern is more intensive, and the diamond pattern is the most intensive. Ranking increases as labor intensity increases.

FLAM MELAMINE LAMINATED FLOORING (SF)

A melamine laminate floor covering system. Composite laminated tongue and groove planks with simulated wood grain designs are typically 47 1/4" x 7 7/8". They are laid over underlayment and joints are glued. Cost includes all material, underlayment, trim molding, glue and labor.

FLP FLAG POLE (LF)

A pole secured in the earth that is used to support a flag. The cost includes a hoisting mechanism and base.

FN HARDENER AND SEALER ON CONCRETE (SF)

Hardener and sealer are treatments applied to a concrete slab floor structure. Hardeners generally fall into two categories: (1) integral: the chemical treatment is mixed with the cement and actually becomes part of the topping mix; and (2) surface when it is applied as the floors are being finished and have become hard enough for traffic. Sealers are also chemical mixtures that are composed of a pigment and reducer. They are designed to minimize stains, seal in moisture, and assist in curing the topping.

FO HARDWOOD (SF)

Floor cover made from oak, maple, poplar, mahogany, walnut, birch, or other broad leaf trees. Each type of hardwood is graded considering thickness, characteristics of the wood (defects and knots), lengths and widths of the individual pieces, and color. This type of floor cover is either nailed or applied with a mastic (adhesive).

FOA SYNTHETIC SPORTS SURFACE (SF)

This floor cover is most commonly found in gyms or sports arenas. It is applied on prepared subsurfaces that are usually made of wood, asphalt, or concrete. Cost does not include subsurface.

FP LINOLEUM (SF)

Composed of ground cork or wood dust, resin, gums, pigments, and linseed oil laid on either a felt, canvas, or burlap backing. Normally comes in rolls of 1/16" to 1/8" thickness. Linoleum is usually cemented to the floor system over a felt base layer.

Rank is influenced by:

- Color: embossed colors are low rank, while tiles with solid coloring throughout are high rank.
- Pattern: marbleized and plain patterns are low rank, while simulated brick and stone patterns are high rank.
- Thickness: sizes vary from 1/8" T (low) to 3/8" T (high).
- Material grade: asphalt and vinyl composition tile materials (low to average) are less than solid vinyl and rubber tile materials (good to high).
- Underlayment: floor covers that are laid on underlayment that has been installed on wood, concrete, or metal subfloor have a higher ranking.
- Coving—topset base: use a higher rank for coved perimeters and topset base molding.

FQ HARDWOOD GYM FLOOR (SF)

A hardwood floor cover that is laid in strips over a subfloor and sleepers.

FR MARBLE (SF)

A tile made of hard limestone. It is installed by setting the tile (usually 6" x 6" to 12" x 12") in a cement bed. The cement bed is usually between 2 and 3 inches thick. The marble is finished by either rubbing or smoothing. The smoothing process involves grinding the tiles to a smooth finish, then polishing.

Rank is influenced by:

—Color: products with natural coloring are low rank, while products with unusual natural or manmade color characteristics are high rank.

—Installation Pattern: the common bond pattern is the least labor-intensive, with the herringbone pattern being more intensive, and the diamond pattern being the most intensive; ranking will increase as labor intensity increases.

FS WOOD COVER CONCRETE, PARQUET (SF)

A hardwood or softwood tile that is laid over sleepers (in mastic) in a decorative pattern to create a parquet design. Standard thickness for the tiles is 5/16", but heavier tile may be between 11/16" and 13/16". The size of the tile also varies from between 9" x 9" and 36" x 36". Edges of tile may be either beveled or squared.

FTA COLORED CHIPS (ADD; SF)

Use this component for the added cost of colored chips in seamless plastic floor (component FJ or FK).

FTB FOUNTAIN BOWL, RESIDENTIAL (EA)

A fiberglass bowl for a residential fountain (component FTR). These bowls are typically 10 inches deep. May also be used for commercial.

Concrete or masonry supports and enclosures are not included in the cost.

Rank 1 for a bowl that is approximately 36 inches in diameter.

Rank 4 for a bowl that is approximately 72 inches in diameter.

FTC FOUNTAIN, COMMERCIAL (EA)

An interior or exterior water fixture used for decorative purposes. Water is circulated through the fountain with a pump and jets to create an artistic effect. Submerged lighting is used to enhance the display.

Cost includes nozzles, spray rings, jets, pumps, drain, overflow system, water supply system, submerged lighting and wiring control panel, and wind control where needed.

The pool (component FTP) is not included in the cost.

The complexity of the spray design and size of the fountain should be considered when selecting a rank.

FTP FOUNTAIN POOL, COMMERCIAL (SF Pool Area)

Shallow site-built masonry (gunite or poured concrete), reflection, or fountain pool.

Rank 1 for pools that are 5–6 feet in diameter.

Rank 4 for pools that are 15–20 feet in diameter.

Use component FTC for the fountain.

FTR FOUNTAIN, RESIDENTIAL (EACH)

An interior or exterior water fixture used for decorative purposes. Water is circulated through the fountain with a pump and jets to create an artistic effect. Submerged lighting is used to enhance the display.

The cost includes nozzles, spray rings, jets, pumps, drain, overflow system, water supply system, submerged lighting and wiring, control panel and wind control where needed.

The bowl (component FTB) is not included in the cost.

FU RUBBER TILE (SF)

Usually found in 9" x 9" or 12" x 12" tiles, 1/8" thick, in a number of different colors. On wood floors, the tile is laid over felt lining using a paste adhesive and then rolled with a large roller to smooth the finish and bond the tile to the felt and subfloor.

Rank is influenced by:

—Color: products with embossed colors are low rank, while products with solid coloring throughout are high rank.

—Pattern: marbled and plain patterns are low rank, with simulated brick and stone patterns at high rank.

—Thickness: sizes vary from 1/8" T (low) to 3/8" T (high).

—Material grade: asphalt and vinyl composition tile materials (low to average) are less than solid vinyl and rubber tile materials (good to high).

—Underlayment: a higher ranking should be allowed for floor covers that are laid on underlayment that has been installed on wood, concrete, or metal subfloor.

—Coving—topset base: use a higher rank for coved perimeters and topset base molding.

FUA RUBBER FABRIC TILE (SF)

A fibrous rubber, velvetlike floor covering made from recycled tires with a vulcanized backing.

FV SLATE (SF)

A granular stone split into thin layers and applied over either a mortar bed or a thin set application. Slate is graded in two categories: (1) clear stock that has no ribbons but has veining in the stone itself, and (2) ribbon stock that has bands of darker color running through it and is the less expensive of the two. In the application, the mortar bed is about 1/4-inch thick, and on top of that, a mastic material is applied to about 1/8-inch thick. The slate flooring is then laid in the mastic. Slate flooring that is generally used for heavier duty floors is between 1/2 and 1 inch and is set on a 1-inch mortar bed (either on slab or wood floor system). When applied over wood floors, it is commonly applied over a felt and lath base.

Rank is influenced by:

—Color: products with natural coloring are low rank, while products with unusual natural or manmade color characteristics (e.g., green slate) are high rank.

—Installation Pattern: the common bond pattern is the least labor-intensive, with the herringbone pattern being more intensive, and the diamond pattern being the most intensive; ranking will increase as labor intensity increases.

FW SOFTWOOD (SF)

A floor cover made from pine, fir, or other softwood conifer trees that have needles or scalelike leaves. This flooring is usually laid in strips and may be nailed or set in mastic.

FX TERRAZZO (SF)

Marble chips in concrete. After the concrete has hardened, the floor is ground and polished by machine to expose the marble chips. It is normally applied in two methods: (1) by bonding the concrete fill and the underbed together, or (2) by separating it from the structural slab. When it is laid over wood floors, the underbed must be at least 2 inches thick.

FY TILE, CERAMIC (SF)

Glazed porcelain tile that comes in a wide variety of sizes, shapes and finishes.

Rank is influenced by:

—Pattern: products with solid, nonpatterned design throughout are a lower rank than products with mosaic patterns.

—Color: white, tan, and other off-white colors are a lower rank than darker colors such as red or black.

—Installation Method: the most labor-intensive (high rank) is the Portland cement method, followed by the dry-set method, followed by the organic adhesive method.

—Cove Base: use a higher rank for coved base along perimeters.

FZ TILE, QUARRY (SF)

Hard-burned, unglazed ceramic tile between 1/2 and 3/4 of an inch thick.

Rank is influenced by:

—Color: products with natural coloring (e.g., red brick and quarry tile) are low rank, while products with unusual natural or manmade color characteristics (e.g., green slate) are high rank.

—Installation Pattern: the common bond pattern is the least labor-intensive, with the herringbone pattern being more intensive, and the diamond pattern being the most intensive; ranking will increase as labor intensity increases.

G WOOD, TREATED (SF Basement Wall Area)

Basement wall constructed of treated wood with the wall thickness depending on the structural requirements of the building.

Cost does not include waterproofing or insulation.

The quality of the interior finish and the quantity and quality of openings should be considered when selecting a rank.

GAA METAL FURRING (ADD; SF)

Furring allows a ceiling finish to be screwed or clipped to a frame and also provides space to run any electrical or utility wiring.

This component may be used with any of the ceiling finish components.

GAB METAL LATH (ADD; SF)

The added cost of a thin metal mesh nailed to rafters or ceiling joists. The lath provides a base for plaster.

This component may be used with any of the ceiling finish components.

GAD MIRROR-FACED PANELS (SF)

An acoustical panel with a clear mirrorlike reflective surface. The cost includes the panel only. Use component GV for the suspension system.

Rank is influenced by thickness of the panels and area covered. Use cost rank 4 for small areas.

GAT ATTACHED GARAGE (SF Garage Area)

Restrictions: Classes C, D, and S only
180–4,000 SF only

A complete garage attached to a residence where a complete or partial wall is common with the residence. The cost includes foundation, floor, exterior walls, roof, car and pedestrian doors, and electrical lighting.

Rank is influenced by:
—Size and shape
—Exterior wall construction
—Extent and quality of finishes

GBU BUILT-IN GARAGE (SF Garage Area)

Restrictions: Classes C, D and S only
180–4,000 SF only

A complete garage completely enclosed within a residence where the living area is separated from the garage area by suitable fire-resistant common walls and ceiling. The cost includes foundation, floor, exterior walls, car and pedestrian doors, and electrical lighting.

Rank is influenced by:
—Size and shape
—Exterior wall construction
—Extent and quality of finishes

GCA GOLF COURSE, MINIMAL QUALITY (EA Hole)

(24–3 Refer to Assessment Practices Manual, Chapter 10, 1/1/86.)

A simply developed budget course on open, natural, or mostly level terrain. This course has small tees and level greens, and few bunkers (sand traps).

The cost includes the normal clearing of the land, incidental grading with minimal contouring, complete irrigation and drainage systems, fairways, service roads, and cart paths.

Bridges, buildings, and lakes are not included in the cost.

The size and layout of the terrain and the size and quality of the irrigation system should be considered when selecting a rank.

GCB GOLF COURSE, SIMPLE DESIGN (EA Hole)

(24–4 Refer to Assessment Practices Manual, Chapter 10, 1/1/86.)

A simply designed course on relatively level terrain with natural rough. This course has few bunkers (sand traps), small built-up tees and greens, and some small trees.

The cost includes the normal clearing of the land, incidental grading with slight contouring, complete irrigation and drainage systems, fairways, service roads, and cart paths.

Bridges, buildings, and lakes are not included in the cost.

The size and layout of the terrain and the size and quality of the irrigation system should be considered when selecting a rank.

<p><u>COURSE</u> Yards: 5,200–6,000 Acres: 65–80 <u>FAIRWAY</u> Acres: 20–25 <u>ROUGH</u> Acres: 40–48</p>

<p><u>COURSE</u> Yards: 6,100–6,400 Acres: 81–100 <u>FAIRWAY</u> Acres: 26–33 <u>ROUGH</u> Acres: 49–60</p>
--

GCC
(24-5) **GOLF COURSE, GOOD DESIGN (EA Hole)**
Refer to Assessment Practices Manual, Chapter 10,
1/1/86.)

This course is typical of a private club. The course is on undulating terrain. It has bunkers (sand traps) at most greens, average elevated tees and greens, some large trees moved in or clearing of some wooded areas, and a driving range.

The cost includes the normal clearing of the land, incidental grading with moderate contouring, complete irrigation and drainage systems, trees, greens, tees, fairways, service roads, and cart paths.

Bridges, buildings, and lakes are not included in the cost.

The size and layout of the terrain and the size and quality of the irrigation system should be considered when selecting a rank.

GCD
(24-6) **GOLF COURSE, CHAMPIONSHIP (EA Hole)**
Refer to Assessment Practices Manual, Chapter 10,
1/1/86.)

This course is on fair to severe undulating terrain with fairway and greens that are bunkered (sand traps) and contoured. It has large tees and greens, large transplanted trees, and a driving range. Championship courses are designed by name architects.

The cost includes the normal clearing of the land, incidental grading with extreme contouring, complete irrigation and drainage systems, service roads, and cart paths.

Bridges, buildings, and lakes are not included in the cost.

The size and layout of the terrain and size and quality of the irrigation system should be considered when selecting a rank.

GCE **GOLF COURSE, MINIATURE, BUDGET (EA Hole)**

A minimum quality, simply developed or prepackaged budget course. This course is typically built on 1/4 acre of flat terrain. The cost includes course lighting.

The cost does not include booths, snack bars, plumbing, or a parking lot.

Use component GCF for standard quality miniature golf courses.

COURSE

Yards: 6,500-6,800

Acres: 101-144

FAIRWAY

Acres: 34-44

ROUGH

Acres: 61-90

COURSE

Yards: 6,900-7,500

Acres: 145-200

FAIRWAY

Acres: 45-60

ROUGH

Acres: 91-120

GCF GOLF COURSE, MINIATURE, STANDARD (EA Hole)

These courses typically have 18 holes on one-half acre. They are professionally designed and installed. The cost includes course plumbing and lighting.

The cost does not include booths, snack bars, or a parking lot.

For prepackaged budget courses, use component GCE.

GCG GOLF COURSE, PITCH AND PUTT (EA Hole)

(24-1) Refer to Assessment Practices Manual, Chapter 10, 1/1/86.)

These courses typically have 9 or fewer holes on 10 to 15 acres and are approximately 1,000 yards long. The layout normally utilizes unbuildable or excess land with minimal or natural contouring and minimal definition of the greens. The cost includes irrigation.

The cost does not include structures or lighting.

The size and quality of the irrigation system should be considered when selecting a rank.

GCH GOLF COURSE, PAR 3 (EA Hole)

(24-2) Refer to Assessment Practices Manual, Chapter 10, 1/1/86.)

These courses typically have 9 holes on 15 to 20 acres and are 1,400-3,000 yards long. The terrain is level with straight fairways. The cost includes irrigation.

The cost does not include structures or lighting.

The size and quality of the irrigation system should be considered when selecting a rank.

GCHE GOLF COURSE, PAR 3, EXPENSIVE (EA Hole)

(24-8) Refer to Assessment Practices Manual, Chapter 10, 1/1/86.)

These courses typically have 9 holes on 15 to 20 acres and are 1,400-3,000 yards long. The cost includes irrigation.

The cost does not include structures or lighting.

The size and quality of the irrigation system should be considered when selecting a rank.

<p><u>COURSE</u> Yards: 1,000 ± Acres: 10-15 <u>FAIRWAY</u> None <u>ROUGH</u> None</p>

<p><u>COURSE</u> Yards: 1,400-3,000 Acres: 15-20 <u>FAIRWAY</u> None <u>ROUGH</u> Possible</p>

<p><u>COURSE</u> Yards: 1,400-3,000 Acres: 15-20 <u>FAIRWAY</u> None <u>ROUGH</u> Possible</p>

GCJ **GOLF COURSE, EXECUTIVE (EA Hole)**
(24-7) Refer to Assessment Practices Manual, Chapter 10,
1/1/86.)

These courses typically have 18 holes on 50 to 60 acres and average 3,100-5,100 yards long and are rated par 60. The cost includes irrigation.

The cost does not include structure or lighting.

The size and quality of the irrigation system should be considered when selecting a rank.

<u>COURSE</u>
Yards: 3,100-5,100
Acres: 50-60
<u>FAIRWAY</u>
None
<u>ROUGH</u>
Possible

GCK **DRIVING RANGE (EA Station)**

A range used to practice hitting golf balls. The cost includes uncovered grass or paved stations, fencing, irrigation, and lighting.

The cost does not include heated tees (component GCM), range covers (GCL), pitching and putting greens, buildings, or equipment.

Rank 1 for grass stations.

Rank 4 for paved stations.

GCL **DRIVING RANGE COVER (ADD; EA Station)**

Use this component for the added cost of covered stations at a driving range (GCK).

GCM **DRIVING RANGE HEATED TEES (ADD; EA Station)**

Use this component for the added cost of heated tees at a driving range (GCK).

GCN **BRIDGE, PEDESTRIAN (SF Bridge Area)**

A pedestrian bridge used to cross a stream, gully, or other impediment at a golf course. The bridge may be made of wood or steel. The supports and handrails are included in the cost.

GCP **BRIDGE, GOLF CART (SF Bridge Area)**

A golf cart bridge used to cross a stream, gully, or other impediment at a golf course. The bridge may be made of concrete, wood, or steel. The supports and guardrails are included in the cost.

GCQ BRIDGE, VEHICULAR (SF Bridge Area)

A small bridge suitable for use by cars and light trucks. The bridge is used to cross a stream, gully, or other impediment at a golf course and is made of concrete, wood, or steel. The supports and guardrails are included in the cost.

GCR LAKE (SF Lake Area)

An artificial body of water. These lakes or reflection ponds are typically found at golf courses or mobile home parks.

The cost does not include a liner.

Use one of the following components for liners:

- GCS Lake Liner, Asphalt
- GCT Lake Liner, Clay
- GCU Lake Liner, Concrete
- GCV Lake Liner, Plastic and Sand

GCS LAKE LINER, ASPHALT (ADD; SF Lake Area)

Use this component for the added cost of an asphalt liner on the bottom of an artificial lake (component GCR).

GCT LAKE LINER, CLAY (ADD; SF Lake Area)

Use this component for the added cost of a clay liner on the bottom of an artificial lake (component GCR).

GCU LAKE LINER, CONCRETE (ADD; SF Lake Area)

Use this component for the added cost of a concrete liner on the bottom of an artificial lake (GCR).

GCV LAKE LINER, PLASTIC AND SAND (ADD; SF Lake Area)

Use this component for the added cost of a plastic and sand liner on the bottom of an artificial lake (GCR).

GCW GOLF COURSE, PLAYER SHELTER (EA)

A prefabricated, 3-sided structure used to provide temporary protection from rain, wind, or sun.

GCX GOLF COURSE LIGHTING (EA Pole)

Outdoor lighting fixtures mounted on poles. These lights provide lighting for nighttime play at a golf course. Wiring is included in the cost.

GDT DETACHED GARAGE (SF Garage Area)

Restrictions: Classes C, D, and S only
180–4,000 SF only

A complete freestanding garage structure. The cost includes foundation, floor, exterior walls, roof, car and pedestrian doors, and electrical lighting.

Rank is influenced by:

- Size and shape
- Exterior wall construction
- Extent and quality of finishes

GDTL DETACHED GARAGE WITH LIVING AREA (SF of Ground Level)

A detached garage with a full second-story living area.

The cost includes foundation, exterior walls, roof, floor structure with floor cover in living area, living area interior partitions, ceiling cover, stairs, electric, vehicle and pedestrian doors.

The cost does not include plumbing, heating and cooling.

Rank 0.5 for open storage with minimum electric.
Rank 1 for minimum partitions (studio or office).

GGA ACOUSTICAL, METAL PANEL (SF)

A smooth or perforated ceiling panel (which can be acoustical) which is usually suspended in a linear pattern. The edges are typically beveled and the panels are held in place on the sides by the runners.

The cost includes the panel only; see component GV for the suspension system.

GGB ACOUSTICAL, MINERAL FIBER (SF)

An acoustical panel made of mineral fiber. It can be applied (glued or stapled) directly to plaster, concrete, or gypsum board or can be attached to furring material. It may also be laid into a suspended ceiling system (see component GV).

GGC ACOUSTICAL, ORGANIC FIBER (SF)

Tiles made of either a wood or cane fiber. The tiles, which are usually square, can be glued or nailed to the ceiling structure directly, attached by furring, or laid in a suspended system. The cost includes the panels or tiles only.

GGD METAL CEILING, EMBOSSED (SF)

A decorative ceiling. The ornamentation is created by raising or indenting a pattern in the metal. The cost includes the ceiling cover only.

Rank 1 for painted ceiling.
Rank 4 for a highly ornamental copper finish.

GH GYPSUM BOARD, TAPED & PAINTED (SF)

Gypsum board (drywall or sheetrock) with the joints taped, spackled, and painted. The gypsum board comes in sheets in varying widths and lengths (the most common being 4' x 8' sheets).

Use a low rank if the gypsum board has been painted with two coats of a flat finish, and the high rank if it has been finished with an enamel paint.

GHA FIBER SPORTS COURT PANEL (SF)

A thick fibrous, prefinished ceiling panel used in sports courts. The cost includes the ceiling panel only. Use component GV for a suspension ceiling.

Rank is influenced by thickness of the panel and quality of the finish.

GHOU GUEST HOUSE (SF Ground Floor)

Restrictions: Must be used in conjunction with Model 011-x

A detached second living unit separate from the main residence.

Cost includes site prep, foundation, exterior walls, roof structure, roof cover, floor, floor cover, plumbing, heat pump, electrical, and interior finish commensurate with the quality of the structure.

GI FINISH ONLY, ON EXPOSED ROOF STRUCTURE (SF)

Paint or stain finish on the exposed underside of a floor or roof system.

GJ PLASTER ON LATH, ACOUSTICAL (SF)

Plaster coats over a lath material. The special acoustical plaster finish coat is designed to deaden sound flow. Typically it is one of two types: (1) gypsum or lime binder, generally troweled on; or (2) adhesive binder that has a tendency to shrink on drying and can be either machine-applied in coats or troweled. The lath is gypsum board (plain, perforated, or insulated). In some older buildings, wood lath may be found.

Use component GAB for metal lath.

GK PLASTER ON LATH, SPRAY-ON (SF)

Plaster applied over gypsum board or lath by machine. Lath material most commonly used in gypsum. This type of plaster finish usually has a thin texture.

Use component GAB for metal lath.

GL PLASTER ON LATH, STANDARD (SF)

Plaster applied in 3 coats over gypsum board or lath. In some older buildings, wood lath may be found. Cost rank should consider smoothness of the final finish. If the ceiling has some waves in the finish of between 1/8" and 3/16", give a lower cost rank than a straight or plumb ceiling finish with only 1/32" to 1/16" variation in the final coat.

Use component GAB for metal lath.

GM PLASTER ON MASONRY, ACOUSTICAL (SF)

Plaster bonded to masonry soffit with acoustical characteristics to lessen sound reverberation.

GN PLASTER ON MASONRY, SPRAY-ON (SF)

A thin-coat finish applied over a masonry soffit.

GO PLASTER ON MASONRY, STANDARD (SF)

Standard plaster finish applied in three coats over a masonry soffit.

GPA PLYWOOD (SF)

A plywood panel applied to the ceiling structure. Typically, it is nailed to the ceiling joists or the roof rafters. Better quality finishes have matched edges, while a lower quality level probably uses some type of strip to cover the butted joints.

Use a low rank for softwood and high rank for hardwood.

GPUM GRINDER PUMP (EA)

Restrictions: Residential models only
Use with municipal sewer systems.

Simplex pump with guide rail disconnect system. Cost includes excavation, installation, and connection, 3-inch diameter by 6-foot deep pump tank, pump controls, and control panel.

The following influence rank:
—Total lift required by pump

GR PLASTIC PANELS (SF)

Used in suspended ceiling systems for the light fixture covering. Can be found in clear panels or may have some sort of a textured finish.

The cost does not include suspension system or lighting. For the suspension system, use component GV.

GS PRINTED HARDBOARD (SF)

A prefinished patterned paneling that generally has plastic coating. Thicker panels (5/8") may be tongue and groove and applied directly to the ceiling frame. Thinner sheets (1/8" to 1/4") require some type of backing for support.

GT WOOD BOARDS (SF)

Individual dimension lumber applied directly to ceiling system.

GTA DECORATIVE CEILING, CARVED WOOD (SF)

Carved wood ceiling panels or ornamental boards. The cost includes the finish and installation.

Rank is influenced by type and quality of wood: lower ranks are for simple border ornamentation; higher ranks are for more extensive and intricate surface designs.

GTB DECORATIVE CEILING, PLAIN DECORATING (SF)

Consists largely of flat or plain color work, some border ornamentation, and stenciling.

For a moderate decorative ceiling, use component GTC.
For an extensive decorative ceiling, use component GTD.

GTC DECORATIVE CEILING, MODERATE DECORATING (SF)

Consists of flat or plain color work, some plaster molding, border, and interior ornamentation and stenciling.

For a plain decorative ceiling, use component GTB. For an extensive decorative ceiling, use component GTD.

GTD DECORATIVE CEILING, EXTENSIVE DECORATING (SF)

Consists of intricate designs in the interior and along the border with considerable ornamentation.

For plain decorative ceiling, use component GTB. For a moderately decorative ceiling, use component GTC.

GU WOOD FURRING (ADD; SF)

Furring allows a ceiling finish to be nailed to a frame and also provides space to run any electrical or utility wiring. It is most commonly used with a concrete slab floor or roof system.

GV SUSPENDED CEILING (ADD; SF)

Use this component for the added cost of a metal support system that is directly attached to the ceiling structure. It is used to support ceiling panels. The suspension system is composed of rigid hangers that support the main runners and the cross members. There is also a network of hanger wires used to help support the suspension system.

Rank is influenced by the quality and finish of the members and complexity of installation.

Use one of the following components for the ceiling panels:

GGA Acoustical, Metal Panel
GGB Acoustical, Mineral Fiber
GGC Acoustical, Organic Fiber
GR Plastic Panels

GW CEILING INSULATION (ADD; SF)

Use this component for the added cost of ceiling insulation. The cost is an average of a number of different types of insulation (fiberglass, rigid, blown fiberglass, etc.).

When selecting a rank, the building's location (climate) should be considered. The more extreme the climate, the higher the rank.

GX CEILING JOISTS (ADD; SF)

Ceiling joists (typically dimension lumber) not part of the roof or floor structure to which the ceiling finish is attached.

Cost rank should be based on the size and spacing of the framing members. The larger the joists and the closer they are to each other, the higher the rank.

GY FIBERBOARD SHEETS (SF)

A fiberboard sheet made of mineral fiber. It is applied (glued, nailed, or stapled) directly to support material.

GZ GYPSUM BOARD, SPRAYED-ON TEXTURE (SF)

Thin-coat plaster sprayed over gypsum board or plaster lath. The most common lath material is Gyplath. This type of plaster usually has a textured finish; common vernacular is popcorn finish.

Use component GAB for metal lath.

H INSULATION (ADD; SF Basement Wall Area)

Use this component for the added cost of insulation in a basement wall.

Rank 1 for 1 1/2" batt.
Rank 4 for 2" rigid board.

HA INTERIOR CONSTRUCTION, FRAMED (SF Floor Area)

Partitions are either wood or steel stud. Finish on the partitions may be either gypsum board (drywall), plaster or some type of paneling, wallpaper, paint, tile or stone, or other high-cost finishes typical of public lobby areas. The cost includes miscellaneous cabinets, shelves, stairs, and other interior items typical for the occupancy being evaluated, such as blackboards in schools. This also includes rest room partitions and miscellany, such as mirrors, towel and soap dispensers, etc.

HAA ATTIC, FINISHED (SF of Attic)

Restrictions: Residential models only

A residential finished attic.

Cost includes floor cover, stairs, interior partitions, ceiling cover, electric, and structural floor.

The cost does not include plumbing, heating or cooling.

Rank is influenced by:
—Quantity of partitions
—Quality of material and workmanship of interior finish

HAL LOFT, OPEN (SF of Loft)

Restrictions: Residential models only

A residential loft without partitions.

The cost includes structural floor, floor cover, soffit finish, typical lighting, railing, and stairs.

HANC INTERIOR CONST., FRAMED, NO COOLERS (SFF)

Restrictions: Models 112x, 113x, 119x, 201x, 202x, 203x, 204x, and 205x only

Partitions are either wood or steel stud. Finish on the partitions may be either gypsum board (drywall), plaster or some type of paneling, wallpaper, paint, tile or stone, or other high-cost finishes typical of public lobby areas. The cost includes miscellaneous cabinets, shelves, stairs, and other interior items typical for the occupancy being evaluated, such as blackboards in schools. This also includes rest room partitions and miscellany, such as mirrors, towel and soap dispensers, etc. The cost does **not** include walk-in coolers, freezers and ancillary cooling equipment.

HAX INTERIOR CONSTRUCTION, FRAMED, RURAL (SF Floor Area)

Restrictions: Quonset Buildings only

Partitions made of either wood or steel studs. The finish is typical of rural occupancies and may be on one or both sides of the partitions. The finish may be wood board, gypsum board (drywall), or simple paneling; painted or unfinished. The cost includes miscellaneous cabinets, shelves, stairs, and other interior items typical of the occupancy being evaluated. Rest room partitions and miscellany, such as mirrors, towel and soap dispensers, etc., are also included.

HAY INTERIOR CONSTRUCTION, FRAMED, INDUSTRIAL (SF Floor Area)

Restrictions: Quonset Buildings only

Partitions made of either wood or steel studs. The finish is typical of industrial occupancies and may be on one or both sides of the partitions. The finish may be wood board, gypsum board (drywall), or simple paneling; painted or wallpapered. The cost includes miscellaneous cabinets, shelves, stairs, and other interior items typical for the occupancy being evaluated. This also includes rest room partitions and miscellany, such as mirrors, towel and soap dispensers, etc.

**HAZ INTERIOR CONSTRUCTION, FRAMED, COMMERCIAL
(SF Floor Area)**

Restrictions: Quonset Buildings only

Partitions made of either wood or steel studs. The finish is typical of commercial occupancies and may be on one or both sides of the partitions. The finish may be wood board, gypsum board (drywall), or simple paneling; painted or wallpapered. The cost includes miscellaneous cabinets, shelves, stairs, and other interior items typical for the occupancy being evaluated. This also includes rest room partitions and miscellany, such as mirrors, towel and soap dispensers, etc.

HB INTERIOR CONSTRUCTION, MASONRY (SF Floor Area)

Partitions are some type of solid masonry construction. Walls may be left exposed or finished with a paint, plaster, gypsum board or paneling on furring, tile or stone, and other high cost finishes typical of public lobby areas. The cost includes miscellaneous cabinets, shelves, stairs, and other interior items typical for the occupancy being evaluated, such as blackboards in schools. This also includes rest room partitions and miscellany, such as mirrors, towel and soap dispensers, etc.

HBX INTERIOR CONSTRUCTION, MASONRY, RURAL (SF Floor Area)

Restrictions: Quonset Buildings only

Partitions are some type of solid masonry construction. The walls may be left exposed or finished with a paint, plaster, gypsum board, or paneling on furring. The cost includes miscellaneous cabinets, shelves, stairs, and other interior items typical for the occupancy being evaluated. This also includes rest room partitions and miscellany, such as mirrors, towel and soap dispensers, etc.

**HBY INTERIOR CONSTRUCTION, MASONRY, INDUSTRIAL
(SF Floor Area)**

Restrictions: Quonset Buildings only

Partitions are some type of solid masonry construction. Walls may be left exposed or finished with a paint, plaster, gypsum board, or paneling on furring. The plaster and gypsum board may have wallpaper or wall covering typical of industrial occupancies. The cost includes miscellaneous cabinets, shelves, stairs, and other interior items typical for the occupancy being evaluated. This also includes rest room partitions and miscellany, such as mirrors, towel and soap dispensers, etc.

**HBZ INTERIOR CONSTRUCTION, MASONRY,
COMMERCIAL (SF Floor Area)**

Restrictions: Quonset Buildings only

Partitions are some type of solid masonry construction. Walls may be left exposed or finished with a paint, plaster, gypsum board, or paneling on furring. The plaster and gypsum board may have wallpaper or wall covering typical of commercial occupancies. The cost includes miscellaneous cabinets, shelves, stairs, and other interior items typical for the occupancy being evaluated. This also includes rest room partitions and miscellany, such as mirrors, towel and soap dispensers, etc.

HDA STAINED GLASS WINDOW (SF Area)

Art glass with highly detailed figures and scenes. The smallest dimension of the dominant pieces is 4 inches or greater.

HDB STAINED GLASS WINDOW (SF Area)

Art glass with highly detailed figures and scenes. The smallest dimension of the dominant pieces is between 2 and 4 inches.

HDC STAINED GLASS WINDOW (SF Area)

Art glass with highly detailed figures and scenes. The smallest dimension of the dominant pieces is less than 2 inches.

HE ACCORDION (SF Wall Partition)

Retractable partitions that are folded in an accordion fashion and may be used to divide an area into two or more rooms. The cost includes the track.

Rank 1 for plain wood or plastic.

Rank 4 for acoustical.

HF BRICK (SF Wall Partition)

Brick construction with the better qualities being face brick. Doorjambes and frames are normally metal. The brick is generally left exposed. The cost includes partition wall and finish and a prorated number of openings and doors but no other interior components.

HG CLAY TILE AND PLASTER (SF Wall Partition)

Structural clay tile (which is a hollow burned-clay masonry unit) with a plaster finish. Tiles are available with a number of surface finishes, but most commonly have a roughened finish designed to receive the plaster. The cost includes a partition wall, finish, and a prorated number of openings and doors.

HH CONCRETE BLOCK (SF Wall Partition)

These partitions are usually made from 4- to 6-inch concrete block. Partitions may be unfinished, partially finished, or finished on both sides. The cost includes partition wall, finish, and a prorated number of openings and doors but no other interior components.

The amount and quality of finish should be considered when selecting a rank.

HI GYPSUM BLOCK (SF Wall Partition)

Gypsum block (sometimes referred to as a tile) is used primarily for fireproofing columns or interior partitions. The face dimensions are usually 12" x 30". The blocks can be from 2 to 6 inches and are generally lightweight. Mortar joints used are 1/4 inch, 3/8 inch, or 1/2 inch. These partitions are painted or unfinished. The cost includes partition wall, finish, and a prorated number of openings.

HJ GYPSUM BLOCK AND PLASTER (SF Wall Partition)

Gypsum block partitions with plaster finish. Plaster is applied over the face of the block or on a metal lath. The cost includes partition wall, finish, and a prorated number of openings and doors.

HKA LAMINATED PLASTIC TOILET PARTITION (EA)

Cost includes complete installation and door.

For privacy screens, use Rank 1.

HKB MARBLE TOILET PARTITION (EA)

This component may also be used for a corian toilet partition. The cost includes complete installation and door.

For privacy screens, use Rank 1.

HKC METAL TOILET PARTITION (EA)

This component may also be used for a baked enamel, stainless steel, or porcelainized toilet partition. The cost includes complete installation and door.

For privacy screens, use Rank 1.

HKD WOOD TOILET PARTITION (EA)

Cost includes complete installation and door.

For privacy screens, use Rank 1.

HL METAL (SF Wall Partition)

Metal panels that may be attached to the wall or floor to form a room or work space divider. The cost includes a partition wall finish and a prorated number of openings and doors, but no other interior components.

Use a low rank for single thickness and high rank for insulated panels.

HM METAL AND GLASS (SF Wall Partition)

Used primarily as room dividers, these partitions are not structural. They are constructed of a metal frame with glass. The cost includes a partition wall finish and a prorated number of openings and doors, but no other interior components.

Rank 4 includes insulated panels.

HN STEEL CHANNELS AND GYPSUM BOARD (SF Wall Partition)

A wall in which the sheets of gypsum (drywall) are separated and held in place by steel channels. The cost includes a partition wall finish and a prorated number of openings and doors, but no other interior components.

The quality of the wall covering should be considered when selecting a rank.

HO STEEL STUDS AND GYPSUM BOARD (SF Wall Partition)

Steel stud construction with gypsum board (drywall) attached to the framing by screws. Joints are covered with tape and spackled. Gypsum board partitions have paint or wall covering as a finish. The cost includes a partition wall finish and a prorated number of openings and doors, but no other interior components.

The quality of the wall covering should be considered when selecting a rank.

HP STEEL STUDS AND PLASTER (SF Wall Partition)

A wall partition made with a steel stud construction and plaster. Plaster is applied to some type of lath, usually gypsum, in either two or three coats. The finish is paint or wall covering. The cost includes a partition wall finish and prorated number of openings and doors, but no other interior components.

The quality of the wall covering should be considered when selecting a rank.

HPBL HISTORICAL PRESERVATION BUILDING (Dollar Amount)

A building that is specially valued using the *reproduction* method. It must be listed in the National Register of Historic Places, which was established and maintained under the National Historic Preservation Act of 1966 as amended. The minimum standards of maintenance must be met that were established by rule of the state parks board.

HQA AIR CURTAIN (SF of Entrance Opening)**HQB AIR CURTAIN, HEAT—FILTERED (SF of Entrance Opening)**

Fans that move air vertically at doorways to prevent loss of heated or cooled air, and also prevent entry of flies.

HR WOOD FRAME, DRYWALL FINISH (SF Wall Partition)

Wood frame, typically 2" x 4", 16 inches on center, with drywall (gypsum board) nailed over it. Joints and nail holes of the drywall are taped and spackled. Depending on the structural requirements of the building, these wood frame partitions may be of 2" x 6" construction. The drywall has some type of finish, either paint or wall covering. The cost includes a partition wall finish and a prorated number of openings and doors, but no other interior components.

The quality of the wall covering should be considered when selecting a rank.

HS WOOD FRAME, PLASTER FINISH (SF Wall Partition)

Wood frame, typically 2" x 4", 16 inches on center, with plaster finish applied over a gypsum or metal lath. The cost includes a partition wall finish and a prorated number of openings and doors, but no other interior components.

HSFC BUILT-IN COOLERS (SF Floor Area)

Used to add the cost of built-in coolers when using the square foot method with the following models: 112, 113x, 119x, 120x, 201x, 202x, 203x, 204x and 205x only.

HT WOOD FRAME, WOOD FINISH (SF Wall Partition)

Wood frame, typically 2" x 4", 16 inches on center, with wood paneling nailed to the frame. The paneling may be in sheets or individual pieces of lumber, i.e., 1" x 6". Depending on the paneling used, it may be nailed to a sheathing material that has been attached to the framing.

HTA UNFINISHED BOARDS, ONE SIDE (SF Wall Partition)

Restrictions: Farm models only

Wood stud partition with unfinished boards on one side, used in farm buildings.

Rank is influenced by the quality, size, and spacing of the studs.

Use component HTC for thicknesses greater than one inch.

HTB UNFINISHED BOARDS, TWO SIDES (SF Wall Partition)

Restrictions: Farm models only

Wood stud partition with unfinished board on both sides used in farm buildings. The cost includes studs and boards.

Rank is influenced by the quality, size, and spacing of the studs.

Use component HTC for thicknesses greater than one inch.

HTC WOOD BOARDS OVER ONE INCH (ADD; SF Wall Partition)

Restrictions: Farm models only

This component is used with components HTA, HTB, and HTD for added cost of each inch of board thickness greater than one inch.

HTD WOOD STUD, SPACED BOARDS, ONE SIDE (SF Wall Partition)

Restrictions: Farm models only

Wood stud partition with unfinished spaced boards on one side, used in farm buildings. Rank is influenced by the quality, size, and spacing of the studs.

Use component HTC for thicknesses greater than one inch.

HTE CONCRETE CURB (LF)

Restrictions: Farm models only

Concrete curb used to separate areas in a livestock building.

Rank is influenced by width and height.

HU TILE (ADD; SF Wall Partition)

Wall tile (ceramic, quarry, etc.) applied as a finish to the interior partition.

Cost does not include the wall framing.

HV CONCRETE (SF Wall Partition)

An interior partition made of formed concrete that has been reinforced. The concrete is typically 6 inches thick. Partitions may be unfinished, partially finished or finished on both sides. The cost includes partition, finish, and prorated number of openings and doors, but no other interior components.

The smoother the finish, the higher the rank.

HWA BASE CABINET (LF)

These cabinets usually range in length from 24 to 48 inches and are approximately 24 inches deep. The sizes generally increase at 3-inch intervals. Base cabinets are designed for various uses, with drawer units, sink or range units, and corner units. Sink or range base cabinets are larger, usually between 54 and 84 inches in length.

Rank 1 for a paint finish.

Rank 4 for hardwood veneer.

HWB WALL CABINET (LF)

Attached to the wall in the kitchen or, in some cases, the baths. The cabinets usually range in length from 24 to 48 inches and are typically only 12 inches deep. Heights of the cabinets vary from 12 to 30 inches.

Rank 1 for a paint finish.
Rank 4 for hardwood veneer.

HWC BROOM CLOSET (LF)

A tall (typically 7 feet) narrow unit used for storage in the kitchen area.

Rank 1 for paint finish.
Rank 4 for a natural finish hardwood.

HWD WATER HEATER CABINET (LF)

A cabinet that houses a hot water heater. These cabinets are generally located on the interior of the property and have sidewalls and a door access to the heater.

Rank 1 for paint finish.
Rank 4 for hardwood veneer.

HWE LINEN CABINET (LF)

These cabinets are usually located in hall or passage area of the house or apartment. They typically have shelving on the interior for storage. Doors are hinged and the cabinets are either hardwood veneer or paint grade material.

Rank 1 for paint.
Rank 4 for hardwood veneer.

HWF PULLMAN CABINET (LF)

These cabinets, also known as vanities, are usually located in the bath area and are attached to both the floor and the wall. Pullman cabinets are not as tall nor as deep as base kitchen cabinets.

Cost does not include top surfaces.

Rank 1 for paint finish.
Rank 4 for hardwood veneer.

HWG WARDROBE (LF)

Use this component for the cabinetry and doors associated with the wardrobe area in a bedroom. The cost includes poles and shelving.

Rank 1 for a paint finish.
Rank 4 for a natural finish hardwood.

HWH OPEN SHELVES (LF)

Exposed shelves designed for storage. The material used varies from 1 to 2 inches thick. The interior shelving may be adjustable or fixed.

HWI BUILT-IN DESK (LF)

This desk is built between two wall sections and may have a section of drawers under the desktop. The desktop may be some type of laminated plastic, natural wood, or paint grade material.

Rank selection should be based on the quality of the desktop and the number of drawers in the unit.

HWJ COUNTERTOP, TILE (LF)

Ceramic tile kitchen countertop. The typical depth of the countertop is 2 feet. The amount of splash area varies (with the better qualities having more splash area). In addition to the splash area, the number of cutouts (i.e., kitchen sink) and corners should be considered when selecting a rank.

HWK COUNTERTOP, LAMINATED PLASTIC (LF)

These countertops are made of laminated plastic and a plywood base. The edging is either metal or self-edged plastic.

HWL COUNTERTOP, STAINLESS STEEL (LF)

Stainless steel, premanufactured unit, typically designed to meet a prescribed kitchen layout, e.g., cutouts and corners.

HWM PULLMAN TOP, TILE (LF)

Ceramic tile countertop for a pullman or vanity in the bath area.

The configuration of the countertop and the amount of splash area (better qualities have more splash area) should be considered when selecting a rank.

HWN PULLMAN TOP, LAMINATED PLASTIC (LF)

Laminated plastic countertop for a pullman or vanity in the bath area. There is characteristically some splash area included.

HWO PULLMAN TOP, MARBLE (LF)

A marble countertop for a pullman. These tops are typically found in excellent quality homes.

HWP PULLMAN TOP, CULTURED MARBLE (LF)

This is a top made of simulated marble material. It is used in most qualities of homes. Cultured marble can also be found as an integral lavatory and countertop unit.

HWQ TUB TILE (EA)

Ceramic tile laid on the wall surrounding the bathtub. The tile extends 4 feet above the tub.

HWR SHOWER TILE, FLOOR AND BASE ONLY (EA)

A ceramic tile floor and base for a shower stall. For a shower stall with tile on the floor and walls, use component HWS.

HWS SHOWER TILE, FLOOR AND WALLS ONLY (EA)

Ceramic tile laid on the walls and floor in a stall shower. The wall tile extends from the base to approximately 6 feet above the floor, on 2 or 3 walls. For a shower stall with tile on the floor and base only, use component HWE.

HWT PREFABRICATED STALL SHOWER (EA)

Premolded fiberglass stall shower units, typically having a floor base and three molded walls with integral valves and shower arm. Interior wall finishes are a baked-on enamel. Generally there are molded soap holders and shelves in the wall sections.

HWU PREFABRICATED TUB-SHOWER (EA)

Premolded fiberglass bathtub with overhead shower. There are three molded walls with integral valves and shower arm. Interior wall finishes are a baked-on enamel.

HWV TUB ENCLOSURE (EA)

A tub enclosure made of a metal or aluminum frame (attached to the wall and the tub) and panels. The panels may be glass, usually tempered, with variations in the glass from clear to patterned. The panels can also be of a shatter-resistant plastic.

HWW SHOWER DOOR (EA)

The door may be metal, glass, or rigid plastic panel. The cost includes a metal frame.

HWX GARAGE WORKBENCH (LF)

A workbench area in a garage or basement. The bench may be constructed of plywood sheets or some type of a 2-inch plank. It is typically attached to the wall and includes some underbench storage.

HWY GARAGE STORAGE (SF Area)

An enclosed storage area in the garage. The cost includes side panels and some type of hinged door(s).

HX INSULATION, FIBERGLASS BATT (SF Wall Area)

Thickness Range: 2"–20" Required in miscellaneous field.

This component includes cost consideration for both fiberglass and mineral wool batt insulation used in cold storage facilities. Typical thickness in between 1 and 10 inches.

HY INSULATION, RIGID (SF Wall Area)

Thickness Range: 2"–20" Required in miscellaneous field.

Rigid insulation used in cold storage facilities. The most common types of board insulation include cork, styrene, foam glass, and polyurethane. The typical thicknesses found vary between 1 and 10 inches.

HZ COLD STORAGE DOORS (SF Door Area)

Thickness Range: 2"–12" Required in miscellaneous field.

Hinged infitting metal clad cold storage doors. Consideration for installation, hardware, and gaskets is included in the cost.

Cost does not include consideration for either electric or pneumatic door operators.

HZG GRANITE (ADD; SF Wall Partition)

Interior partitions with a granite wall facing. These partitions are commonly found in monumental or governmental type structures. This component should be used primarily with the alternate method for interior construction. However, it can also be used with the primary method when a higher cost finish is required.

HZH LIMESTONE (ADD; SF Wall Partition)

Interior partitions with a limestone wall facing. These partitions are commonly found in higher cost structures. This component should be used primarily with the alternate method for interior construction. However, it can also be used with the primary method when a higher cost finish is required.

HZI LOCAL STONE (ADD; SF Wall Partition)

A stone found in the same general geographic region as the structure, typically sandstone, attached as a wall facing to an interior partition. This component should be used primarily with the alternate method for interior construction. However, it can also be used with the primary method when a higher cost finish is required.

HZJ MARBLE (ADD; SF Wall Partition)

Interior partitions with a marble wall facing attached to the basic wall. The marble can be found in a number of colors and is usually highly polished. This component should be used primarily with the alternate method for interior construction. However, it can also be used with the primary method when consideration for the higher cost finish is required.

HZW COOLER DOOR, WALK-IN BOX (ADD; EA)

Hinged infitting glass door for walk-in boxes. Size of door is typically 30" x 67". Consideration for installation, hardware, gaskets, shelving, and lighting is included in the cost.

Rank is influenced by:

- Height of door
- Reversibility of door
- Quality of material and workmanship of door

IA PLUMBING (SF Floor Area)

This component can be used where there is an even distribution of plumbing fixtures to floor area (offices, hotels, apartments, single family residences and other types of housing). Costs do not include process piping for industrial applications.

The quantity and quality of the individual fixtures should be considered when selecting a rank.

IAX PLUMBING, RURAL (SF Floor Area)

Restrictions: Quonset Buildings only

This component can be used where there is an even distribution of plumbing fixtures to floor area in a typical rural occupancy. The cost does not include process piping for manufacturing type applications.

The quantity and the quality of the individual fixtures should be considered when selecting a rank.

IAY PLUMBING, INDUSTRIAL (SF Floor Area)

Restrictions: Quonset Buildings only

This component can be used where there is an even distribution of plumbing fixtures to floor area in a typical industrial occupancy. The cost does not include process piping for manufacturing type applications.

The quantity and the quality of the individual fixtures should be considered when selecting a rank.

IAZ PLUMBING, COMMERCIAL (SF Floor Area)

Restrictions: Quonset Buildings only

This component can be used where there is an even distribution of plumbing fixtures to floor area in a typical commercial occupancy. The cost does not include process piping for manufacturing type applications.

The quantity and the quality of the individual fixtures should be considered when selecting a rank.

IB PLUMBING FIXTURES (EA Fixture)

This component can be used in occupancies where the number of plumbing fixtures varies in relation to the floor area, i.e., industrial buildings. The cost includes the rough and finish plumbing associated with the fixture.

The quality of the fixtures and the length of runs for supply and waste lines are the primary considerations in the cost rank selection.

IC BATHTUB (EA)

Bathtubs can be constructed of enameled cast iron, fiberglass, or pressed enameled steel, with costs descending in that order. Typical dimensions are 60 inches long, 30 inches wide, and 15–16 inches high.

ID SHOWER OVER TUB (ADD; EA)

This component is used when there is a shower arm in the tub area. It accounts for the additional cost of piping and valves associated with the shower in a tub area.

IE KITCHEN SINK (EA)

These sinks can be enameled cast iron, porcelain, enameled steel, or stainless steel. They are typically either single or double.

Use rank 3 or 4 for double sinks.

IF LAUNDRY TRAY (EA)

These can be either single or double compartment tubs generally associated with the washer–dryer area of a residence. They have swing spout faucets and drains.

IG LAVATORY (EA)

Located in the bathroom areas, they can be either vitreous china, porcelain-enameled steel, or stainless steel.

Colored fixtures are typically more expensive than white. These units may also be integral with a simulated marble countertop unit (component HWP). The cost includes the fixture, water and waste piping, faucets, and valves.

IGA PLASTIC WATER SYSTEM (SF Area Covered)

Restrictions: Commercial Greenhouse model only

Plastic tube water distribution system in a commercial greenhouse.

Rank 1 for a spray system.

Rank 4 for a drip-tube system.

IGB AUTOMATIC WATER SYSTEM CONTROLS (EA)

Restrictions: Commercial Greenhouse model only

Automatic controls used with a water distribution system in a commercial greenhouse. The cost includes timers. Piping is not included in the cost.

Rank 1 for a mechanical system.

Rank 4 for a solid state system.

IH TOILET (EA)

A toilet constructed of vitreous china, usually having some type of jet flushing action. Tank sizes vary. The cost includes associated rough plumbing, water supply, and valves.

IJ STALL SHOWER (EA)

Shower with two or three walls of ceramic tile or hardboard material. Typical size is 3 feet square but varies with design layout of the bath area. The cost includes necessary piping, pan, valves, and shower arm. Wall finishes are a part of interior construction costs.

IK WATER HEATER (EA)

These heaters have an enameled steel outer jacket with a capacity of between 20 gallons and 82 gallons. They may be either gas or electric. New models have some energy-saving control devices. Installed linings are of polyurethane foam or fiberglass.

IL ROUGH-IN (EA)

Hot and cold water service and waste associated with the washer-dryer connection. The cost includes the necessary piping and valves.

IM HYDRO-TUB (EA)

Bathtub fixture with pumped circulating water. The cost includes pipe connections, pumps, motors, and controls.

Rank is influenced by:

- Size and composition of tub
- Complexity of controls
- Number of water jets

IN BIDET (EA)

A toiletlike bathroom fixture used for hygienic washing of the lower parts of the body. Cost includes fixture, labor, and miscellaneous materials for rough and finish.

ISTC SEWAGE TREATMENT PLANT, CONCRETE (Gallons per Day)

ISTS SEWAGE TREATMENT PLANT, STEEL (Gallons per Day)

A complete concrete or steel sewage treatment plant. The cost includes all costs (all structures and equipment) of the plant when ready for operation. The gallon per day capacity is the rated capacity of the plant.

Rank 1 for 100,000 to 500,000 gallons a day

Rank 2 for 50,000 to 99,999 gallons a day

Rank 3 for 30,000 to 49,999 gallons a day

Rank 4 for Up to 30,000 gallons a day

ISW SOLAR HOT WATER HEATER (Number of Units)

A solar water heating system that includes a flat or thermosyphon collector and an 80-gallon hot water storage tank (gas or electric backup). Gas or electric not included.

Rank 1 for a capacity less than 60 gallons.

Rank 2 for a capacity of 80 gallons.

Rank 3 for a capacity of 100 gallons.

Rank is influenced by:

- Capacity and type of system
- Size and installation complexity of collector panel

Note: In order to comply with the provisions regarding Solar Energy Devices in HB 2429, **ISW** will not generate a cost on improvement listings in the Construction Cost System starting in Tax Year 2008.

ISX SEPTIC TANK (EA)

A complete self-contained waste disposal system used where no sewer system is available.

Rank is influenced by the size of the tank.

Use the following rank table:

GALLONS	RANK	GALLONS	RANK
750	1.0	2,000	2.8
1,000	1.7	2,500	3.0
1,250	2.0	4,500	4.0
1,500	2.3	—	—

IW WET BAR, RESIDENTIAL (EA)

A stainless steel single sink that is typically smaller and deeper than an ordinary sink. All necessary plumbing is included in the cost.

IZ PLUMBING DRAIN (EA)

A rough plumbing floor or roof drain for water. Cost includes the necessary piping and drain fixture.

JA SPRINKLERS (SF Floor Area)

Systems vary depending on their design characteristics. They are either concealed or exposed systems and wet or dry. The cost includes piping, heads, valves, meter, and hangers.

The type of system has a bearing on cost rank selection. A wet system has water in the lines, while a dry system pumps water into the lines from a source as required. Concealed dry systems are the most expensive and exposed wet systems are least expensive.

JAB SPRINKLERS, EXTRA HAZARD (SF Floor Area)

A heavy system used for extra hazard occupancies. These sprinklers typically have more heads or nozzles than average hazard systems. The cost includes piping, heads, valves, meter, and hangers.

See component JA for more information.

JAC SPRINKLERS, DOUBLE HEADS (SF Floor Area)

These sprinklers have heads both above and below the ceiling. The cost includes piping, heads, valves, meter, and hangers.

See component JA for more information.

JBA AUXILIARY LIGHT PACKS, SINGLE HEAD (EA)

Used primarily for emergency lighting. Cost includes ancillary connections. Lead acid batteries are generally found at the lower cost ranges. High cost ranges usually include nickel cadmium batteries.

JBD FIRE ALARM CONTROL PANEL, 1 ZONE (EA)

An alarm panel, sometimes referred to as an indicator panel, which indicates the origin of a signal from a fire alarm system. The system may be some type of automatic or water flow alarm.

For additional zones, use component JBE.

JBE ADDITIONAL ZONES (EA)

A subdivided area in a building that is individually protected by the fire prevention system. Separate controls for each independent area allow for specific activation or shut down of the system.

Note: For a control panel, use component **JBD**.

JBF PULL STATION (EA)

These units are part of a fire alarm system. They are usually located in common areas (e.g., corridors) and are operated manually. Pull stations may be noncoded or coded to indicate the floor area or zone in which the signal originated. Both single action and double action pull stations are included.

JBG SMOKE DETECTOR, HARDWIRED IN SYSTEM (EA)

A device that senses visible or invisible particles of combustion. The cost includes combination smoke and heat, and duct-mounted units.

JBH FIRE CONTROL ROOM PANEL (EA 75 Zones)

A panel that is part of an automatic sprinkler or fire alarm system with the capability to monitor, at a central station, 75 alarm signals. This control panel is generally supervised by trained personnel and may be designed with a direct circuit connection to a local fire department.

Note: For a smaller (1 zone) panel, use component **JBD**.

JBJ PANEL SPEAKER (EA)

Speakers connected with a microphone at the control panel. They may be designed as a 1-way or 2-way communication system or as some type of audible alarm system.

JBK EMERGENCY TELEPHONE (EA 5 Jacks)

Special leased telephone lines that allow transmission of fire and trouble signals from the property to a central fire station. These lines are generally monitored for shorts and openings.

JBL WATER FLOW DETECTOR (EA)

Part of a sprinkler system that indicates an alarm once water has been discharged. This alarm can be used with both wet and dry systems.

JBM DATE—TIME—LOCATION PRINTER (EA)

A computer printer designed to document specific information about the activation of the fire alarm/sprinkler system. It is normally located in a central area and associated with the control room panel and alarm display.

JBN BATTERY STANDBY SYSTEM (EA)

A battery-operated fire alarm system designed to work in case of power failure. It generally includes some type of alarm bell and indicator lamp.

JBP OUTSIDE STANDPIPE (EA Hose Outlet)

A fire line system that runs the entire height of a building. It may be either a wet or dry system. Size of pipe varies between 2 and 8 inches. Cost includes all necessary piping, fittings, and installation.

The cost does not include valves.

JBQ INSIDE STANDPIPE (EA Hose Outlet)

A standpipe system that is commonly a wet system with water always available in the risers and at the outlets. The cost includes all necessary piping (e.g., system main, risers), fittings, and installation. Size of pipe varies between 2 and 8 inches.

The cost does not include valves.

JBR SIAMESE CONNECTION (EA)

A piping connection composed of at least two multiple inlet fittings. It is commonly installed on the exterior of a building and connected to both the risers and the main. Typically used by the local fire department to supply water to the system. Exposed connections may be straight body, angle body, or freestanding. Concealed connections are flush mounted, with 2-way or 3-way inlets.

JBU MASONRY CHIMNEY, 8-INCH ROUND, SQUARE FLUE (LF)

Average cost per foot of height. The cost includes tile flues and foundation.

For use primarily in residential applications.

JBV MASONRY CHIMNEY, 10-INCH ROUND, SQUARE FLUE (LF)

Average cost per foot of height. The cost includes tile flues and foundation.

For use primarily in residential applications.

JBW MASONRY CHIMNEY, TWO 8 INCHES, ROUND SQUARE (LF)

A masonry chimney with two 8" flues, either round or square, for use primarily in residential applications. Average cost per foot of height. The cost includes tile flues and foundation.

JBX GALVANIZED CHIMNEY, 6-INCH DIAMETER (LF)

Light gauge round galvanized metal chimney stacks, including ancillary items, for use primarily in residential applications.

JBY GALVANIZED CHIMNEY, 8-INCH DIAMETER (LF)

Light gauge round galvanized metal chimney stacks, including ancillary items, for use primarily in residential applications.

JBZ GALVANIZED CHIMNEY, 10-INCH DIAMETER (LF)

Light gauge round galvanized metal chimney stacks, including ancillary items, for use primarily in residential applications.

JC HEAT—RATE OF RISE DETECTOR (EA)

A sensory instrument which measures surrounding temperature and activates an alarm or other systems.

JCA METAL, STACK, DOUBLE WALL (LF)

Light gauge metal chimney stack with two walls separated by an insulating space, used in residential construction.

Rank is influenced by:
—Presence or type of insulation fill
—Type and gauge of metal
—Complexity of installation

JCB METAL STACK, TRIPLE WALL (LF)

Light gauge metal chimney stack with three walls separated by an insulating space, used in residential construction.

Rank is influenced by:
—Presence or type of insulation fill
—Type and gauge of metal
—Complexity of installation

JFH FIRE HYDRANT (EA)

A discharge pipe with a valve and spout designed to deliver a high volume of water from a water main via hoses to extinguish fires.

KA ELECTRIC (SF)

Radiant type heating, either cable, panel, or baseboard.

KAY SOLAR HEATING, LIQUID SYSTEM (SF of Collector Panel)

Complete heating and cooling system using solar collectors as the source of energy and liquid transfer systems.

Cost includes piping, storage facilities, ducting, heat exchangers, and ancillary equipment. It does not include supplementary or backup systems.

Rank is influenced by:

- Capacity and type of system
- Size and installation complexity of collector

Note: In order to comply with the provisions regarding Solar Energy Devices in HB 2429, **KAY** will not generate a cost on improvement listings in the Construction Cost System starting in Tax Year 2008.

KAZ SOLAR HEATING, AIR SYSTEM (SF of Collector Panel)

Complete heating and cooling system using solar collectors as the source of energy and air transfer systems.

Cost includes storage facilities, ducting, heat exchangers, and ancillary equipment. It does not include supplementary or backup systems.

Rank is influenced by:

- Capacity and type of system
- Size and installation complexity of collector

Note: In order to comply with the provisions regarding Solar Energy Devices in HB 2429, **KAZ** will not generate a cost on improvement listings in the Construction Cost System starting in Tax Year 2008.

KB ELECTRIC WALL HEATERS (SF)

These are electric units in the wall capable of heating small areas. They may be utilized as supplemental heating to the main heating plant (e.g., to heat the office area in a warehouse).

KBM INDIVIDUAL THRU-WALL HEAT PUMP (SF)

A small heat pump that is designed to be installed in a window opening or wall. Unlike larger heat pumps, it services only 1 room.

Principal heating codes indicate gas or electric fuel to be standard.

KC FORCED AIR (SF)

Gas-fired or electric-powered heating system with the warm air circulated by a motor driven fan. Cool air is taken from various points in the building, passed over the combustion chamber and flue, and distributed throughout the duct system.

This system is fueled by gas. For an alternate fueling or firing, use B, C or O.

KD FLOOR FURNACE (SF)

Located under the floor, the unit generates heat from a self-contained furnace, which passes into a room through a floor grate. There is no duct work.

Costs vary by the capacity of the unit, with dual units at the high end.

This system is fueled by gas. For an alternate fueling or firing method, use B, C or O.

KF GRAVITY FURNACE (SF)

The main heating plant on this system is usually located in a lower level of the building and operates on the principle that heat rises to pass the warm air through the ductwork to upper levels of the building. The ducts are included in the cost.

This system is fueled by gas. For an alternate fueling or firing method, use B, C or O.

KGA DUCT, FAN JET (ADD; SF)

Restrictions: Commercial Greenhouse models only

Use this component for the added cost of jet ducts for space heaters (component KGJ) in commercial greenhouses.

The capacity of the system should be considered when selecting a rank.

KGD EXHAUST FAN (EA)

Restrictions: Commercial Greenhouse models only

Ventilation fan used in a commercial greenhouse.

The capacity of the system should be considered when selecting a rank.

KGE GAS FURNACE (SF)

Restrictions: Commercial Greenhouse models only

Gas-fired hot air furnace system in commercial greenhouses. The cost includes ducts and ancillary connections.

The capacity of the system should be considered when selecting a rank.

KGF HOT WATER HEATING (SF)

Restrictions: Commercial Greenhouse models only

Hot water generated by the use of a boiler and pumped (under pressure) to unit heaters throughout the building in commercial greenhouses. The cost includes ancillary connections.

The capacity of the system should be considered when selecting a rank.

KGG HUMIDIFIER (EA)

Restrictions: Commercial Greenhouse models only

A humidifier in a commercial greenhouse.

The capacity of the system should be considered when selecting a rank.

KGJ SPACE HEAT (SF)

Restrictions: Commercial Greenhouse models only

Suspended space heaters in commercial greenhouses.

The capacity of the system should be considered when selecting a rank.

KGK HUMIDITY PAD, WATER DRIP (SF Pad Area)

Restrictions: Commercial Greenhouse models only

A moisture-absorbing fiber pad used with a fan system to distribute water vapor in a commercial greenhouse. The cost includes pad, pad housing, sump, water pump, drip distributor.

Fans and ducts are not included in the cost.

The capacity of the system should be considered when selecting a rank.

KGL STEAM HEAT (SF)

Restrictions: Commercial Greenhouse models only

Steam generated by the use of a boiler and piped, on its own pressure, to unit heaters throughout the building in commercial greenhouses. The cost includes ancillary connections.

The capacity of the system should be considered when selecting a rank.

KGM VENT, AUTOMATIC (EA)

Restrictions: Commercial Greenhouse models only

A vent with automatic controls used in conjunction with a fan system to ventilate a commercial greenhouse. The cost includes controls and installation.

The fan system is not included in the cost.

The sensitivity of the controls should be considered when selecting a rank.

KH HOT WATER (SF)

A boiler and exposed baseboard or radiator network. Water is circulated through piping and baseboards or radiators. The boiler may be fired by coal, oil, or gas. The cost includes an expansion tank and piping.

The size of the boiler, number of accessories, intricacy of the piping system, and the number of temperature zones influence the rank selection.

The system is fueled by gas. For an alternate fueling or firing method, use B, C, or O.

KI RADIANT HOT WATER (SF)

Water is heated by circulation over coils or through a boiler. The water is then circulated through concealed pipes.

This system is fueled by gas. For an alternate fueling or firing method, use B, C, or O.

KJ SPACE HEAT, GAS (SF)

A complete individual unit suspended from the ceiling or roof structure. Within the unit there is a fan blower system used to move the warm air. This type of system is generally utilized in structures with large open areas. This system is fueled by gas.

KK SPACE HEAT, STEAM (SF)

A complete individual unit that is generally suspended from the ceiling or roof structure. Within the unit is a fan or blower system used to move the warm air. This type of system is generally found in structures with large open areas.

This system is fueled by gas.

KL STEAM WITH BOILER (SF)

Steam generated by the use of a boiler and piped, by its own pressure, to radiators throughout the building.

This system is fueled by gas. For an alternate fueling or firing method, use B, C, or O.

KM STEAM WITHOUT BOILER (SF)

A radiator system receiving steam from an external source.

KN HOT AND CHILLED WATER (SF)

A zoned heating and cooling system that uses hot or chilled water. The water is generated from a central location and piped to various sections of a building. Each section of the building has fin coils or convectors with fans. These are used to produce warm or cooled air that is then circulated throughout that portion of the building. This system is normally found in Class A and B high-rise buildings where fire barriers must be penetrated from floor to floor.

Year-round ambient temperature, the number of temperature zones, and the overall quality of the equipment should be considered when selecting a rank.

This system is fueled by gas. For an alternate fueling or firing method, use B, C, or O.

KO WARM AND COOLED AIR (SF)

Similar to hot and chilled water except that the warm and cooled air is generated at the main plant and distributed throughout the building by a long, complex system to numerous zoned areas. This system offers combined heating and cooling.

This system is fueled by gas. For an alternate fueling or firing method, use B, C, or O.

KP PACKAGE HEATING AND COOLING (SF)

Basically the same as central air (warm and cooled air) except for the capacity and amount of ductwork involved. Typically, a package system contains one short duct and thermostat per unit, and it is not uncommon to find a number of individual units servicing one building. A split system is a type of package that has gas-fired, forced-air heating with either gas or electric refrigerated or evaporative cooling. These are complete individual roof or ground units having their own individual compressors and furnace.

This system is fueled by gas. For an alternate fueling or firing method, use B, C, or O.

KQ HEAT PUMP (SF)

A self-contained, reverse-cycle heating and cooling system. On its heating cycle, heat is collected by the outside coil and pumped inside the building. On its cooling cycle, the heat is collected from the inside and pumped to the outside coil where it is dissipated. Costs include simple single-zoned, self-contained or split system package units and multizoned systems. The systems are electric or gas–electric powered, including supplemental electric coils.

KQM HEAT PUMP WITHOUT DUCTWORK (SF)

Restrictions: Mobile home models only

A self-contained, reverse-cycle heating and cooling system. On its heating cycle, heat is collected by the outside coil and pumped inside the building. On its cooling cycle, the heat is collected from the inside and pumped to the outside coil where it is dissipated. The systems are electric or gas–electric powered, including supplemental electric coils. Use for heat pumps where there is existing mobile home ductwork. Costs include simple single-zoned, self-contained or split system package units and multizoned systems.

Costs do not include ductwork.

NOTE: Do not use if the heat pump was included with the mobile home at the time of purchase or was included in the price listed on the dealer invoice.

KR EVAPORATIVE COOLING (SF)

A cooling unit—usually roof-mounted—which cools the air by water evaporation. Outside air is drawn through a moistened filter pad in the plant and cooled air is then circulated throughout the interior. They are usually single-ducted packaged units or relatively short ducted central systems. This type of system is commonly found in arid climates.

KRA EVAPORATIVE COOLING, WITHOUT DUCTING (SF)

Restrictions: Residential models only

A cooling unit—usually roof-mounted—which cools the air by water evaporation. Outside air is drawn through a moistened filter pad in the plant and cooled air is then circulated throughout the interior. This system is commonly found in arid climates.

Use for evaporative cooling where ducting is shared with heating or refrigerated cooling.

Costs do not include ductwork.

KSM AIR CONDITIONING WITHOUT DUCTWORK (SF)

Restrictions: Mobile home models only

This type of system is for cooling only. The cooling unit, a condenser, can be located outside the mobile home or in a mechanical area within the structure. Generally, air is drawn through the system over refrigerated tubes or coils. Once the air is cooled, it is distributed through the mobile home ductwork. Use for air conditioning where ductwork is shared with the mobile home forced-air system.

Costs do not include ductwork.

NOTE: Do not use if air conditioning was included with the mobile home at time of purchase or was included in the price listed on the dealer invoice.

KS REFRIGERATED COOLING (SF)

This type of system is for cooling only. The cooling unit, a condenser, can be located outside the building or in a mechanical area within the structure. Generally, air is drawn through the system over refrigerated tubes or coils. Once the air is cooled, it is distributed through the building ductwork.

KT VENTILATION (SF)

Air circulation via fans and ducts.

KU WALL FURNACE (SF)

Small furnace either electric-powered or gas-fired, vented to the outside by vertical and/or horizontal ductwork. This is a relatively low-cost heating system that can be found in both lower quality and older structures.

Cost rank selection should consider the number of units within the structure (the more units, the higher the rank selection).

This system is fueled by gas. For an alternate fueling or firing method, use B, C, or O.

KX SPACE HEAT, STEAM WITHOUT BOILER (SF)

Steam heat circulated by space heaters. The steam is generated at an independent source. The cost includes piping and installation.

The boiler or other steam generator is not included in the cost.

Rank is influenced by:

- Type and size of the space heaters
- Complexity of the installation
- Sophistication of controls

KYA COMPLETE HVAC (SF)

Restrictions: Restaurants and Medical Facilities only

Complete heating and cooling system for restaurants, general hospitals, and surgical centers. The cost includes heating, cooling, and ventilating units, ductwork, plumbing, and electrical connections and controls commensurate with the model.

Rank is influenced by:

- Number and complexity of controls
- Design of system

KYB COMPLETE HVAC (SF)

Restrictions: Shopping Center models only

Complete heating and cooling system for an enclosed pedestrian mall (component MLH). The cost includes heating, cooling, and ventilating units, ductwork, plumbing, and electrical connections and controls.

Rank is influenced by:

- Number and complexity of controls
- Design of system

KYC CLEAN ROOM Class 100,000 to 10,000 (SF Floor)

Restrictions: Garages, Industrials, Lofts, and Warehouses

This cost range represents cleaned space that has no more than 100,000 to 10,000 particles of 0.5 microns or larger per cubic foot of air.

Clean room space is classified by the number of particles of a certain size present in a cubic foot of air. Humidity and temperature are also carefully controlled to predetermined purity standards. The constant filtered air changes required in a clean room environment are referred to as laminar flow. Costs represent clean room area only and account for the additional HVAC, filtering, piping, and the wall, ceiling, and floor finishes required for a clean space envelope.

Each clean room space is specifically engineered, therefore costs can vary greatly, and cost ranges should be used with caution. Wherever possible, use actual contract costs.

KYD CLEAN ROOM Class 1,000 to 100 (SF Floor)

Restrictions: Garages, Industrials, Lofts, and Warehouses

This cost range represents cleaned space that has no more than 1,000 to 100 particles of 0.5 microns or larger to 100 particles of 0.3 microns or larger per cubic foot of air.

Clean room space is classified by the number of particles of a certain size present in a cubic foot of air. Humidity and temperature are also carefully controlled to predetermined purity standards. The constant filtered air changes required in a clean room environment are referred to as laminar flow. Costs represent clean room area only and account for the additional HVAC, filtering, piping, and the wall, ceiling, and floor finishes required for a clean space envelope.

Each clean room space is specifically engineered, therefore costs can vary greatly, and cost ranges should be used with caution. Wherever possible, use actual contract costs.

KYE CLEAN ROOM Class 100 to 10 (SF Floor)

Restrictions: Garages, Industrials, Lofts, and Warehouses

This cost range represents cleaned space that has no more than 100 particles no larger than 0.3 microns to 10 or fewer particles of 0.12 microns or less per cubic foot of air.

Clean room space is classified by the number of particles of a certain size present in a cubic foot of air. Humidity and temperature are also carefully controlled to predetermined purity standards. The constant filtered air changes required in a clean room environment are referred to as laminar flow. Costs represent clean room area only and account for the additional HVAC, filtering, piping, and the wall, ceiling, and floor finishes required for a clean space envelope.

Each clean room space is specifically engineered, therefore costs can vary greatly, and cost ranges should be used with caution. Wherever possible, use actual contract costs.

KZ RADIANT GAS (SF)

Gas-fired suspended radiant heating units with piping and controls. The cost includes heater unit, piping, reflectors, suspension supports and ancillary items.

Rank is influenced by:

- Capacity and density of burners
- Lower ranks do not have vacuum pumps and may not have reflectors
- Higher ranks have vacuum pumps and reflectors in a continuous pipe loop system

LA ELECTRICAL, FINISHED (SF)

Includes all costs associated with the electrical system, including the building's general distribution service, wiring, outlets, and fixtures. Interior decorative lighting that is incidental to the building is included. Exterior decorative lighting is not included in the costs. Costs do not include power distribution wiring, fixtures, or equipment for industrial applications.

LAB LAWN AREA (SF Area)

Grass covered (lawn) area. The cost includes fine grading, seeding, and fertilizing.

Rank 1 for hydromulching.
Rank 4 for placed sod.

LAC LANDSCAPED AREA (SF Area)

Complete landscaping including grass, shrubs, ground cover, plants, trees, and irrigation.

The following influence rank:

- Size of shrubs: Rank 1 has 1–5 gallon shrubs.
Rank 4 has 5–15 gallon shrubs.
- Size of trees: Rank 1 has a 15–gallon, 20" box.
Rank 4 has a 42" box and larger.
- Lawn: Rank 1 is seeded.
Rank 4 is sod.
- Irrigation: Rank 1 is manual.
Rank 4 is automatic.
- Size of area covered: Rank 1 for a large open area.
Rank 4 for a small dense area.

LAM LANDSCAPE, DESERT–GRASS (SF of Area)

Moderate desert or grass landscaping including an irrigation system made of underground piping and sprinkler heads, minimal shrubs, plants, and trees.

Rank 1 for large areas with rain birds or a rain jet system.
Rank 4 for small areas.

LAS SPRINKLERS (SF Area)

An irrigation system made of underground piping and sprinkler heads. The cost includes valves and pressure regulators.

Rank 1 for large areas with rain birds or a rain jet system.
Rank 4 for small areas (typical or residential applications).

-
- LAX** **ELECTRICAL, FINISHED, RURAL, QUONSET (SF)**
LAY **ELECTRICAL, FINISHED, INDUSTRIAL, QUONSET (SF)**
LAZ **ELECTRICAL, FINISHED, COMMERCIAL, QUONSET (SF)**

Electrical, finished. Includes all costs associated with the electrical system, including the building's general distribution service wiring, outlets, and fixtures typical of each of the above occupancies. Costs do not include power distribution, wiring, fixtures, or equipment for industrial applications.

- LB** **ELECTRICAL, UNFINISHED AREA (SF)**

Electrical lighting system suitable for an unfinished area of a building (e.g., basement, attic, or storage area). The cost includes service distribution wiring, switches, outlets, and fixtures.

- LBX** **ELECTRICAL, UNFINISHED, RURAL, QUONSET (SF)**
LBY **ELECTRICAL, UNFINISHED, INDUSTRIAL, QUONSET (SF)**
LBZ **ELECTRICAL, UNFINISHED, COMMERCIAL, QUONSET (SF)**

Unfinished electrical lighting system suitable for an unfinished area of a building, e.g., basement, attic, or storage area, typical of each of the above occupancies. The cost includes service distribution wiring, switches, outlets, and fixtures.

- LC** **BASIC POWER SERVICE, SERVICE STATION (EA)**

Restrictions: Service Station only

An electrical power service with two circuits. The cost includes panel box, meter, circuit breakers, wiring, switches, and lighting fixtures.

For additional circuits, use component LD.

- LD** **ADDITIONAL CIRCUITS, SERVICE STATION (EA)**

Restrictions: Service Station Only

This component is used for the added cost of additional circuits to a basic power service (component LC). The cost includes circuit breakers, wiring, switches, and fixtures.

LE INCANDESCENT LIGHTING WITHOUT POLE (EA)

Incandescent outdoor light fixture. The cost includes wiring and installation.

Use component LH for poles.

LF FLUORESCENT LIGHTING WITHOUT POLE (EA)

Fluorescent outdoor light fixture. The cost includes wiring and installation.

Use component LH for poles.

LG HIGH-INTENSITY, SODIUM-MERCURY VAPOR WITHOUT POLE (EA)

High-intensity sodium or mercury vapor fixture for outdoor lighting. The cost includes wiring and installation.

Use component LH for poles.

LGL EXTERIOR LIGHTING, DECORATIVE (EA Light)

Decorative yard lights, on the ground or on poles, used to spotlight or highlight walkways and planted area. Wiring is included in the cost.

LGP LIGHTING (EA 12-foot Pole)

Outdoor lighting fixture and a 12-foot metal pole. The cost includes wiring.

Rank 1 for incandescent.

Rank 2 for fluorescent.

Rank 3 for mercury vapor.

Rank 4 for high-pressure sodium.

LH LIGHT POLES FOR ABOVE LIGHTS (LF)

Metal utility pole to support lighting fixtures.

Use component LE (incandescent lights), LF (fluorescent lights), or LG (high intensity lights) for lighting fixtures.

LIG PARKING LOT LIGHTING (SF Area Served)

Cost includes poles and underground conduit. The pole height varies between 12 and 24 feet. The fixtures commonly used are incandescent, fluorescent, mercury vapor, or high-pressure sodium, with ranking from low to high.

LJ GREENHOUSE (SF Greenhouse Area)

Size Range: 50–1,000 SF

Stock residential greenhouse. The cost includes foundation, framing, glazing, vents, and doors. Cost does not include heating, electrical, floor, plumbing, watering devices, and planting benches.

Rank is influenced by:

- Frame: Rank 1 for wood or aluminum.
Rank 4 for tubular with concealed connections.
- Glazing: Rank 1 for plain glass.
Rank 4 for insulated glass.

LJA GREENHOUSE HEATER (ADD; EA)

Use this component for the added cost of a heater in a residential greenhouse (component LJ).

LJB GREENHOUSE HUMIDIFIER (ADD; EA)

Use this component for the added cost of a humidifier in a residential greenhouse (component LJ).

LJC GREENHOUSE COOLER (ADD; EA)

Use this component for the added cost of an installed cooling unit in the residential greenhouse (component LJ).

LOF LOFTS (SF)

Restrictions: Farm models only

A complete elevated, mezzaninelike wood floor that is generally used to store hay. These floors are commonly found in barns. The cost includes supports.

May be used in addition to HA and HB for interior construction.

Ranks 1 and 2 are wood planks.
Ranks 3 and 4 are tongue and groove with heavy timber supports.

MAA STEEL STUDS AND STUCCO (SF Wall Area)

Steel stud curtain wall (non-load-bearing) with stucco exterior combined with glass and an interior wall finish attached to a structural frame. Cost includes stucco, studs, lath and plaster or drywall, and areas of glass and doors appropriate to the given model and overall building rank.

Rank is influenced by:

- Quantity and quality of windows and doors
- Quality of material and workmanship of exterior and interior wall finishes

MAB FACING TILE (ADD; SF Wall Area, Per Side)

This addition adjusts for the difference in cost between block and tile with the factory-applied glazed facing and standard block or tile.

This component is used with any of the following:

- MG Concrete Block, Standard
- XW Concrete Block, Cavity
- MZ Clay Tile

MAC INSULATION FOR CURTAIN WALL (ADD; SF Wall Area)

Used for the added cost of batt or rigid insulation inserted between the interior and exterior surfaces of curtain walls. Costs are applied only to the spandrel or insulated areas of the curtain wall.

Building location and climate should be considered when selecting a rank; the more extreme the climate, the more insulation typically used.

MAD SIDING, ALUMINUM (SF Wall Area)

Various types of aluminum or steel siding attached to either wood or metal stud wall. May be found in sheets or conventional lap siding. Cost includes windows and doors appropriate to the given model and overall building rank. For sheathed backing, add component MBR. For sheet siding, use a low rank; for insulated lap siding, use a high rank.

Rank is influenced by:

- Quantity and quality of windows and doors
- Quality of material and workmanship of exterior and interior wall finishes

MAE SIDING, ASBESTOS (SF Wall Area)

Siding composed of asbestos fiber and Portland cement. Typically a light gray color. Generally applied over sheathing on a wood or steel stud wall. Cost includes windows and doors appropriate to the given model and overall building rank. For sheathed backing, add component MBR.

Rank is influenced by:

- Quantity and quality of windows and doors
- Quality of material and workmanship of exterior and interior wall finishes

MAF SHINGLES, WOOD (SF Wall Area)

Wood shingles which may have regular, irregular, or thatched butts. Most bundles of shingles are furnished in random widths and applied over spaced sheathing and a building paper, or they may come in single or tiered panels. The shingles are thin, and small units are laid in overlapping layers. The cost includes windows and doors appropriate to the given model and overall building rank. For sheathed backing, add component MBR.

Rank is influenced by:

- The amount of exposure each shingle has to the weather; the lower the exposure, the higher the rank
- Quantity and quality of windows and doors
- Quality of material and workmanship of exterior and interior wall finishes

MAG SHAKES, WOOD (SF Wall Area)

Thin pieces of wood split from a larger bolt of wood. The primary difference between wood shingle and wood shakes is thickness of the split wood. The cost includes windows and doors appropriate to the given model and overall building rank. For sheathed backing, add component MBR.

Rank is influenced by:

- The amount of exposure each shingle has to the weather; the lower the exposure, the higher the rank
- Quantity and quality of windows and doors
- Quality of material and workmanship of exterior and interior wall finishes

MAH STUCCO (SF Wall Area)

Stucco (exterior plaster) that is the primary exterior wall finish. Applied over paper and wire (either an integral wire and paper or an individual paper and wire), stucco is composed of a Portland cement base and sand. Cost includes windows and doors appropriate to the given model and overall building rank. If a solid sheathing serves as a backing for the stucco and wire finish, the sheathing must be added using component MBR.

The following influence rank:

- Quantity and quality of windows and doors
- Quality of material and workmanship of exterior and interior wall finishes

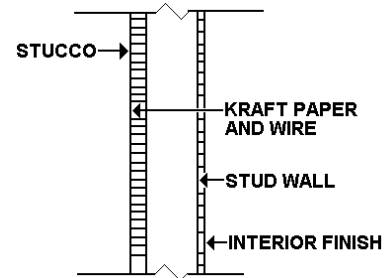
**MAI STUCCO, WITH SHEATHING (SF Wall Area)**

Stucco (plaster) used as the primary exterior wall finish. The finish is applied over paper and wire (either an integral wire and paper or an individual paper and wire) and supported by sheathing. The stucco is composed of a Portland cement base and sand. The cost includes windows and doors appropriate to the given model and overall building rank.

Rank is influenced by:

- Quantity and quality of windows and doors
- Quality of material and workmanship of exterior and interior wall finishes

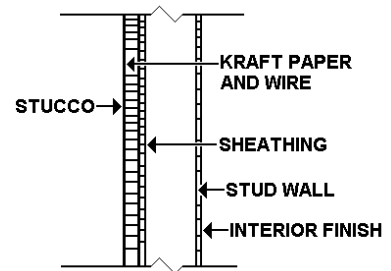
**MAJ SIDING, WOOD (SF Wall Area)**

Wood siding finish that is applied over a paper backing on a wood or metal stud frame. The siding may be either drop or lap siding.

If the siding is applied over a sheathing, the sheathing must be added using component MBR. The cost includes windows and doors appropriate to the given model and overall building rank.

Rank is influenced by:

- Quantity and quality of windows and doors
- Quality of material and workmanship of exterior and interior wall finishes

MAL VENEER, COMMON BRICK (SF Wall Area)

Brick facing (common brick, clay) applied to a stud frame to give the appearance of brick structure. Held to the wood or metal frame by small corrugated strips of metal fastened to the sheathing at the studs and embedded in mortar. Cost includes windows and doors appropriate to the given model and overall building rank. For sheathed backing, add component MBR.

Rank is influenced by:

- Quantity and quality of windows and doors
- Quality of material and workmanship of exterior and interior wall finishes

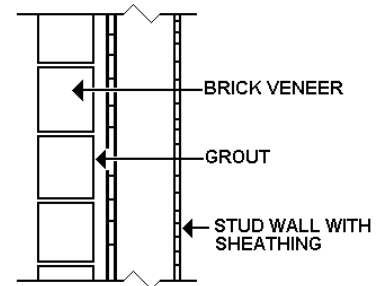
**MAM VENEER, FACE BRICK (SF Wall Area)**

Face brick veneer (glazed or unglazed) applied to a stud frame to give the appearance of brick structure. Held to the wood or metal frame by small corrugated strips of metal fastened to the sheathing at the studs and embedded in mortar. Cost includes windows and doors appropriate to the given model and overall building rank. For sheathed backing, add component MBR.

Rank is influenced by:

- Quantity and quality of windows and doors
- Quality of material and workmanship of exterior and interior wall finishes

MAN VENEER, STONE (SF Wall Area)

Stone veneer laid in regular or irregular patterns. Attached to a wood or metal stud using metal clips. Cost includes windows and doors appropriate to the given model and overall building rank. For sheathed backing, add component MBR.

Rank is influenced by:

- Quantity and quality of windows and doors
- Quality of material and workmanship of exterior and interior wall finishes

MAP SIDING, VINYL (SF Wall Area)

Siding with a vinyl-coated surface on the exposed side. May be applied directly to the studs or over some type of sheathing. Use a high rank for insulated vinyl lap siding. Cost includes windows and doors appropriate to the given model and overall building rank. For sheathed backing, add component MBR.

Rank is influenced by:

- Quantity and quality of windows and doors
- Quality of material and workmanship of exterior and interior wall finishes

MAQ SIDING, TEXTURED PLYWOOD (SF Wall Area)

Plywood siding panels, applied in sheets. The exposed surface is treated to give the plywood a solid wood board effect. Normal application requires some type of a blocking material to be used for nailing to the stud wall. Cost includes windows and doors appropriate to the given model and overall building rank. For sheathed backing, add component MBR.

Rank is influenced by:

- Thickness of the panel: the thicker the panel, the higher the rank
- Type of lumber: low ranks for fir or pine; high ranks for redwood or cedar
- Quantity and quality of windows and doors
- Quality of material and workmanship of exterior and interior wall finishes

MAS LOG, RUSTIC (SF Wall Area)

A solid wall using various diameters of logs. The logs are usually tongue and groove, spiked, or doweled using weather sealant or caulking. Normally, logs are pretreated with a preservative. Cost includes windows and doors appropriate to the given model and overall building rank.

Rank is influenced by:

- Quantity and quality of windows and doors
- Quality of material and workmanship of exterior and interior wall finishes

MAU INSULATION FOR WOOD OR STEEL STUD (ADD; SF Wall Area)

Cost is an average of a number of different types of insulation (fiberglass, blown fiberglass, etc.) to be added to a wood or steel stud bearing wall. For rigid boards, use sheathing component MBR. The location and climate should be considered when selecting a rank; the more extreme the climate, the more insulation typically used.

- Rank 1 for 2 1/2" batts, R-7.
- Rank 2 for 3" batts, R-11.
- Rank 3 for 3 1/2" batts, R-13.
- Rank 4 for 6" batts, R-19.

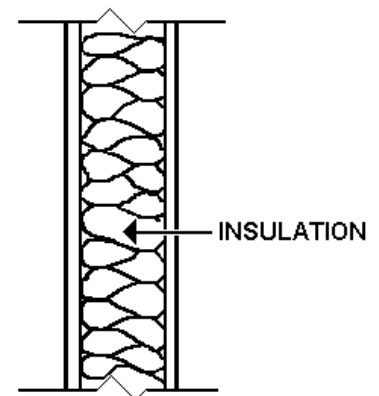

MAY METAL COVER, STEEL FRAME (SF Wall Area)

A single wall of preformed (corrugated or ribbed) metal sheet siding attached to the exterior of a skeleton steel frame. The cost includes wall girts and windows and doors appropriate to the given model and overall building rank. For exterior sheathing, use component MBS; for interior sheathing, finished, use component MBC.

The quantity and quality of windows and doors should be considered when selecting a rank.

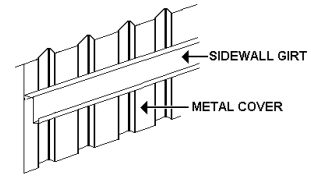
**MAZ METAL COVER, WOOD FRAME (SF Wall Area)**

A single wall of preformed (corrugated or ribbed) metal sheet siding attached to the exterior of a skeleton wood frame. Cost includes wall girts, and windows and doors appropriate to the given occupancy and overall building rank. For exterior sheathing, use component MBS; for interior sheathing, finished, use MBC.

The quantity and quality of windows and doors should be considered when selecting a rank.

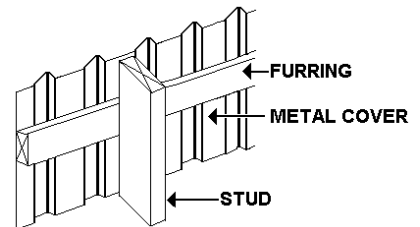
**MB BRICK, BLOCK BACK-UP (SF Wall Area)**

Thickness Range: 6"–36" Required in miscellaneous field.

Solid masonry wall composed of an exterior course of common brick and interior backup courses of standard block. Typically 8 to 12 inches or more in thickness. Cost includes mortar, reinforcing (where necessary), and windows and doors appropriate to the given model and overall building rank. For face brick, add component code ME.

Rank is influenced by:

- Quantity and quality of windows and doors
- Quality of material and workmanship of exterior and interior wall finishes

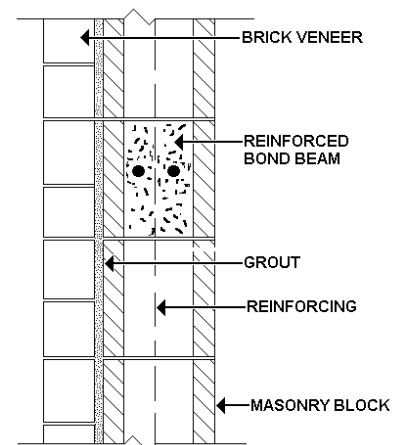
**MBA TRANSITE, STEEL FRAME (SF Wall Area)**

A very dense material made of Portland cement and asbestos fibers. Sheets are ribbed or corrugated with the single wall attached to the exterior of the skeleton steel frame. Cost includes wall girts, windows, and doors appropriate to the given model and overall building rank. For exterior sheathing, use component MBS; for interior sheathing, finished, use MBC.

The following influence rank:

- Quantity and quality of windows and doors
- Quality of material and workmanship of exterior and interior wall finishes

MBB SIDING, WOOD FRAME (SF Wall Area)

Single wall wood siding attached to the exterior of a skeleton wood frame. Types of siding vary, but typically are lower cost plywood or board sidings. Cost includes wall girts, windows and doors appropriate to the given model and overall building rank. For exterior sheathing, use component MBS; for interior sheathing, finished, use MBC.

Rank is influenced by:

- Quantity and quality of windows and doors
- Quality of material and workmanship of exterior and interior wall finishes

MBC SHEATHING, INTERIOR (ADD; SF Wall Area)

This is an added cost to single walls for finished interior sheathing applied over a skeleton frame.

Rank is influenced by type of material and finishes.

Low ranks for exposed plywood.

High ranks for finished drywall.

MBH SANDWICH PANEL, GLASS EXTERIOR, METAL INTERIOR (SF Wall Area)

Insulated sandwich panel with structural glass exterior and prefinished metal interior panel. Cost includes windows and doors appropriate to the given model and overall building rank. The quantity and quality of windows and doors should be considered when selecting a rank.

MBJ SANDWICH PANEL, ASBESTOS CEMENT, TWO SIDES (SF Wall Area)

Insulated sandwich panel with asbestos cement exterior and interior. The cost includes windows and doors appropriate to the given model and overall building rank.

MBK SANDWICH PANEL, STEEL EXTERIOR, GYPSUM BOARD INTERIOR (SF Wall Area)

Insulated sandwich panel with metal exterior and gypsum board interior. The cost includes windows and doors appropriate to the given model and overall building rank.

MBN ASPHALT SIDING (SF Wall Area)

Wood or steel stud bearing wall with asphalt siding generally applied over sheathing. The cost includes windows and doors appropriate to the given model and overall building rank.

For sheathed backing, use component MBR.

Rank is influenced by:

- Quantity and quality of windows and doors
- Quality of material and workmanship of exterior and interior wall finishes

MBP SANDWICH PANEL, METAL, TWO SIDES (SF Wall Area)

Insulated sandwich panel with metal exterior and interior. The cost includes windows and doors appropriate to the given model and overall building rank.

Rank is influenced by:

- Quantity and quality of windows and doors
- Quality of material and workmanship of exterior and interior wall finishes

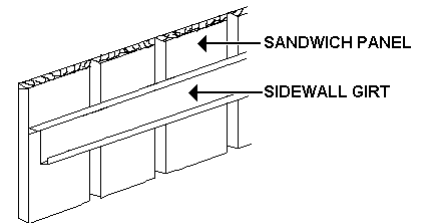

MBR SHEATHING (ADD; SF Wall Area)

The component is for the added cost of exterior sheathing on wood or steel stud bearing walls.

Rank is influenced by thickness and composition of sheathing. The building location and climate should be considered also. The more extreme the climate, the thicker the sheathing.

MBS SHEATHING, EXTERIOR (ADD; SF Wall Area)

Use this component for the added cost of exterior sheathing used in single wall construction.

Rank is influenced by thickness and composition of sheathing. The building's location and climate should be considered also. The more extreme the climate, the thicker the sheathing.

MBT INSULATION (ADD; SF Wall Area)

Use this component for the added cost of batt insulation used in single wall construction. Building location and climate should be considered when selecting a rank. The more extreme the climate, the more insulation typically used.

MBU SYNTHETIC PLASTER ON RIGID INSULATION (ADD; SF Wall Area)

Use this component for the added cost of synthetic plaster on rigid insulation exterior wall finish over masonry walls. Cost is for the exterior insulation board and finish only. Thickness of insulation should be considered when selecting a rank.

MBV GLASS BLOCK WALL (SF Wall Area)

White, clear, or aqua glass block wall. Cost includes mortar, appropriate reinforcement, and windows and doors appropriate to the given model and overall building rank.

Rank is influenced by:

- Quantity and quality of windows and doors
- Quality of material and workmanship of exterior and interior wall finishes

MBW SANDWICH PANELS, METAL, TWO SIDES, COLD STORAGE (SF Wall Area)

Insulated metal sandwich panel on exterior wall in cold storage facilities. The cost includes windows and doors appropriate to the given model and overall building rank.

Rank is influenced by:

- Quantity and quality of windows and doors
- Quality of material and workmanship of exterior and interior wall finishes

MBX ALUMINUM-VINYL SIDING ON MASONRY (ADD; SF Wall Area)

Insulated aluminum or vinyl lap siding applied with furring strips to an existing exterior masonry wall. Costs are for veneer facing only.

MC BRICK, COMMON (SF Wall Area)

Thickness Range: 4"–36" Required in miscellaneous field.

A masonry wall composed of common clay bricks only. The bricks are typically two or more rows thick, with each row grouted together. The structural requirements of the wall determine the thickness of the mortar bed joint, usually between 1/8" and 3/4". The design and structural requirements influence the type of bond used in the wall. Cost includes mortar, reinforcing (where necessary), and windows and doors appropriate to the given model and overall building rank.

For face brick, add component ME.

Rank is influenced by:

- Quantity and quality of windows and doors
- Quality of material and workmanship of exterior and interior wall finishes

MCB SIDING, HARDBOARD (SF Wall Area)

Applied over either a wood or metal stud wall. Individual hardboards are generally composed of a wood fiber that has been pressed into a board form and may be tempered or treated to provide extra strength and durability. Exposed exterior surfaces may be embossed. The cost includes windows and doors appropriate to the given model and overall building rank.

For sheathed backing, add component MBR.

Rank is influenced by:

- Quantity and quality of windows and doors
- Quality of material and workmanship of exterior and interior wall finishes

MCC SYNTHETIC PLASTER ON RIGID INSULATION (SF Wall Area)

Wood or steel stud bearing wall with synthetic plaster on rigid insulation exterior and interior wall finish. The cost includes studs, mesh reinforcing, drywall or plaster interior finish, and windows and doors appropriate to the given model and overall building rank.

Rank is influenced by:

- Quantity and quality of windows and doors
- Quality of material and workmanship of exterior and interior wall finishes

MCE AIR INFILTRATION WRAP (SF Wall Area)

Restrictions: Residential models only

Use this component for the added cost of high density polyethylene fibrous exterior air barrier applied to the studs in residential construction.

Rank is influenced by the number of openings and difficulty of installation.

MCF HARDBOARD SHEET SIDING (SF Wall Area)

Wood or steel stud bearing wall with hardboard sheet siding exterior and interior wall finish. The cost includes studs, drywall or plaster interior finish, and windows and doors appropriate to the given model and overall building rank.

For sheathed backing, add component MBR.

Rank is influenced by:

- Quantity and quality of windows and doors
- Quality of material and workmanship of exterior and interior wall finishes

MCG BRICK, 6-INCH SCR MODULAR (SF Wall Area)

An exterior wall made of single course of common SCR (cored) brick. The cost includes mortar, reinforcing (where necessary), and windows and doors appropriate to the given model and overall building rank.

For face brick, add component ME.

MCH VENEER, FACE BLOCK (SFW)

A stud frame wall with an exterior masonry veneer face block cover to give the appearance of a solid block wall. The block is held to the frame by small corrugated strips of metal that are fastened to the sheathing at the studs and embedded in mortar. The cost includes windows and doors appropriate to the given occupancy and overall building rank.

For sheathed backing, add component MBR.

MD BRICK, CAVITY (SF Wall Area)

Thickness Range: 4"–36" Required in miscellaneous field.

Two single walls constructed of common clay brick and separated by air space. The walls are held together by ties placed in the mortar bed joints of the structure at various intervals. The air space provides a barrier against the penetration of moisture to the inner side of the wall, and in the higher ranks is grouted and reinforced. The cost includes mortar, reinforcing (where necessary), and windows and doors appropriate to the given model and overall building rank.

For face brick, add component ME.

Rank is influenced by:

- Quantity and quality of windows and doors
- Quality of material and workmanship of exterior and interior wall finishes

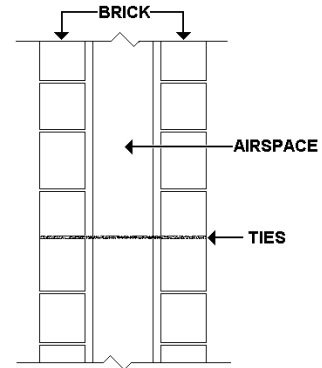
**MDA STEEL HANGAR DOOR (SF of Door)**

Restrictions: Airplane Hangar models only

Small steel hangar doors (up to 20 feet high) used in aircraft hangars only.

Rank is influenced by:

- Presence of pedestrian doors
- Thickness of panels
- Extent of operating mechanisms
- Openings for aircraft protrusions

MDB STEEL HANGAR DOOR (SF of Door)

Restrictions: Airplane Hangar models only

Medium-size steel hangar doors (from 20 to 40 feet high) used in aircraft hangars only.

Rank is influenced by:

- Presence of pedestrian doors
- Thickness of panels
- Extent of operating mechanisms
- Openings for aircraft protrusions

MDC STEEL HANGAR DOOR (SF of Door)

Restrictions: Airplane Hangar models only

Large-size steel hangar doors (over 40 feet high) used in aircraft hangars only.

Rank is influenced by:

- Presence of pedestrian doors
- Thickness of panels
- Extent of operating mechanisms
- Openings for aircraft protrusions

ME FACE BRICK (ADD; SF Wall Area)

This addition adjusts for the difference in cost between a better quality face brick and common clay brick in place.

This component can be used with any of the following:

- MB Brick, Block Backup
- MC Brick, Common
- MD Brick, Cavity
- XZ Brick, Cavity, Block Backup
- MCG Brick, 6-Inch SCR Modular

MEA FACE BLOCK (ADD; SF Wall Area)

This addition adjusts for the difference in cost between decorative face block and standard block in place.

- Rank 1 for slump block.
- Rank 2 for fluted.
- Rank 3 for split face.
- Rank 4 for ground face.

This component can be used with any of the following:

- MG Concrete Block, Standard
- XW Concrete Block, Cavity

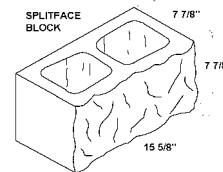
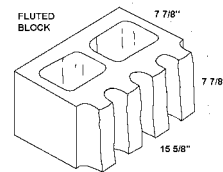
**MEB ASBESTOS, WOOD FRAME (SF Wall Area)**

A single wall of siding that is composed of asbestos fiber and Portland cement. The siding is attached to a skeleton wood frame. The cost includes wall girts, and windows and doors appropriate to the given model and overall building rank.

For sheathing, use component MBS (exterior) or component MBC (interior).

MEC ASPHALT SIDING, WOOD FRAME (SF Wall Area)

Restrictions: Farm models only

A single wall of asphalt siding that is attached to a skeleton wood frame. The cost includes wall girts, windows and doors appropriate to the given model and overall building rank.

For sheathing, use component MBS (exterior) or component MBC (interior).

MED FIBERGLASS, WOOD FRAME (SF Wall Area)

A single wall of fiberglass siding that is attached to a skeleton wood frame. The cost includes wall girts, and windows and doors appropriate to the given model and overall building rank.

MEE STUCCO, WOOD FRAME (SF Wall Area)

A single wall of stucco (composed of a Portland cement base and sand) that is attached to a skeleton wood frame. The cost includes wall girts and windows and doors appropriate to the given model and overall building rank.

MEF BOARDS OVER ONE INCH (ADD; SF Wall Area)

Restrictions: Farm models only

This component is used for the added cost of boards over an inch thick. This component is used with component MEG (Single Wall, Spaced Boards) or MBB (Solid Boards).

MEG SPACED BOARDS (SF Wall Area)

Restrictions: Farm models only

A single wall of spaced wood boards (under an inch thick) that are attached to a skeleton frame. The cost includes wall girts, windows, and doors appropriate to the given model and overall building rank.

For boards over an inch thick, add component MEF.

MFB STAY-IN-PLACE FRAME, BELOW-GRADE (ADD; SFW)

An additive for basement walls constructed of poured-in-place concrete, where the forming materials remain in place. Forms used for the wall are usually some type of rigid insulation board and tie system or preformed blocks.

MG CONCRETE BLOCK, STANDARD (SF Wall Area)

Thickness Range: 6"–36" Required in miscellaneous field

A solid masonry wall made of standard concrete blocks and mortar. The blocks are rectangular in shape and typically have inner openings (cores). These cores reduce the weight of the block as well as provide a space for reinforcing bars. Cost includes mortar, reinforcing (where necessary), and windows and doors appropriate to the given model and overall building rank.

For face block, add component MEA. For glazed tile face, add component MAB.

Rank is influenced by:

- Quantity and quality of windows and doors
- Quality of material and workmanship of exterior and interior wall finishes

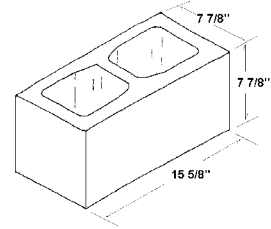
**MGA GREENHOUSE, CURTAIN, AUTOMATIC SIDEWALL ASSEMBLY (LF of Curtain)**

Restrictions: Commercial Greenhouse models only.

Motorized operator used to raise and lower sidewalls in a commercial greenhouse.

MGB MASONRY STEM WALL (LF)

Restrictions: Commercial Greenhouse models only

This component is used to add the cost of a concrete or block perimeter wall approximately 2 feet high above ground, which serves as a protective barrier. The cost includes cast-in-place concrete with sill plate or block and mortar with sill plate.

The thickness of the wall should be considered when selecting a rank.

MH CONCRETE, TILT-UP (SF Wall Area)

Thickness Range: 4"–36" Required in miscellaneous field.

A wall generally used in large, one-story structures (industrial shell buildings) which may or may not be load-bearing. The wall section is formed on top of a concrete slab floor structure. A liquid bond breaker is used between the slab and the to-be-poured wall section (so that the wall and slab do not bond together). Once the concrete in the section is cured, it is lifted into place by crane on top of the foundation. The cost includes windows and doors appropriate to the given model and overall building rank.

Rank is influenced by:

- Quantity and quality of windows and doors
- Quality of material and workmanship of exterior and interior wall finishes

MHA MOBILE HOME, WATER AND SEPTIC (EA Space)

Water and septic facilities for a mobile home in a mobile home park.

MHE MOBILE HOME, ELECTRICAL SERVICE (EA Space)

Electric power service for a mobile home space. The cost includes the pedestal, panel box, circuit breaker, and service wiring.

- Rank 1 for 15–60 amps.
- Rank 2 for 61–199 amps.
- Rank 4 for 200 amps.

MHG MOBILE HOME, GAS SERVICE (EA Space)

Gas service for a mobile home in a mobile home park.

MHP MOBILE HOME PARK, SITE PREPARATION (SF of Lot)

This special DOR component is based upon the assumption that a mobile home park is similar to an outdoor theater in site preparation in that a large area is cleared in order to prepare the site for installation of multiple units of a similar type.

Enter average size of mobile home lot in the units field, enter total number of lots in the miscellaneous field. (For average size, sum the square foot area of all the lots in the park and divide by the total number of lots.)

MHT SEWAGE TREATMENT, PRIVATE SYSTEM (ADD; EA Space)

Use this component for the added cost of sewage treatment to mobile home water and sewage facilities (component MHW).

The more mobile home sites serviced by the facility, the lower the rank.

MHW MOBILE HOME, WATER AND SEWER (EA Space)

Water and sewer facilities for a mobile home in a mobile home park.

MHX SEPTIC TREATMENT, PRIVATE SYSTEM (EA)

A sewage disposal system in which a continuous flow of waste material is decomposed by anaerobic bacteria.

Use MHX for the added cost of septic treatment to mobile home water and septic facilities (MHA). The more mobile home sites serviced by the facility, the lower the cost rank.

MI STONE, ASHLAR, VENEER, BLOCK (SF Wall Area)

Thickness Range: 6"–36" Required in miscellaneous field.

Some type of veneer stone, usually limestone, attached to a concrete block backup wall using metal wall ties. Irregular-shaped stones are laid into an ashlar facing pattern. The stone may be finished with a random rough bed or a split face sawed bedding surface. The cost includes mortar, reinforcing (where necessary), and windows and doors appropriate to the given model and overall building rank.

Rank is influenced by:

- Quantity and quality of windows and doors
- Quality of material and workmanship of exterior and interior wall finishes

MICF INSULATING CONCRETE FORM WALLS (SF Wall Area)

An exterior wall constructed of poured-in-place concrete, where the forming materials remain in place as part of the wall system. The forms used for the wall are usually some type of rigid insulation board and tie system or preformed blocks. The cost includes forming material, rebar reinforcing, concrete, exterior and interior finish and all windows and doors typical of the model and grade.

Do **not** enter wall thickness in miscellaneous field

Do **not** add component MM - wall insulation

MJ STONE RUBBLE (SF Wall Area)

Thickness Range: 8"–36" Required in miscellaneous field.

A wall made of various-shaped fieldstone built without coursing or regularity, attached to a concrete block backup wall using metal wall ties. The amount of mortar required depends on the size and shape of the stone and the thickness of the wall. The cost includes mortar, reinforcing (where necessary), and windows and doors appropriate to the given model and overall building rank.

Rank is influenced by:

- Quantity and quality of windows and doors
- Quality of material and workmanship of exterior and interior wall finishes

MK PILASTER (ADD; SF Wall Area)

This is an additive to masonry walls for a column usually formed of the same material as the exterior wall (brick, block, or concrete). It is generally integral with and projecting from the wall. In concrete tilt-up walls, pilasters can form the component that ties the wall sections together.

ML BOND BEAMS (ADD; SF Wall Area)

Use this component for the added cost of continuous beams placed in masonry walls. These beams add lateral stability and distribute concentrated vertical loads along the wall. Bond beams are usually made of reinforced concrete or reinforced concrete block.

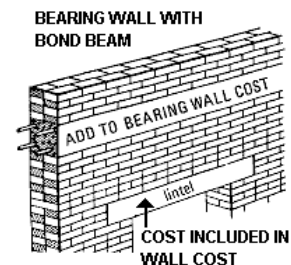

MLC COVERED MALL (ADD; SF Concourse Area)

Covered but open to the air pedestrian concourse between stores. The cost includes paving, roof, roof supports, lighting, and ornamentation.

Stores and signs are not included in the cost.

Rank 1 for light trellises, concrete, adequate illumination.

Rank 2 for metal or wood canopies, terrazzo or decorative concrete, good illumination.

Rank 3 for substantial structure, good mansard, pavers, high quality illumination.

Rank 4 for complete roof, carpeting and vinyl floor cover, lighting, and public rest room plumbing.

MLE ENCLOSED MALL (ADD; SF Concourse Area)

Completely enclosed pedestrian concourse between stores. The cost includes flooring, roof, roof supports, planters, entrances, public rest rooms, lighting, heating and cooling, and ornamentation. Stores, kiosks, elevators, escalators, and signs are not included in the cost.

Rank 1 for light built-up roof, exposed deck, concrete, adequate lighting and plumbing.

Rank 2 for light built-up roof, exposed deck, carpet and vinyl, planters, adequate lighting and plumbing.

Rank 3 for good built-up roof, parapets, plaster or drywall ceilings, pavers and terrazzo, planters, good lighting and plumbing.

Rank 4 for high-cost roof, parapets, domed skylights, plaster or drywall ceilings, pavers and terrazzo, planters, special lighting and plumbing.

MLH ENCLOSED MALL (ADD; SF Concourse Area)

Completely enclosed pedestrian concourse between stores. The cost includes flooring, roof, roof supports, planters, entrances, public rest rooms, lighting, and ornamentation. Stores, kiosks, heating and cooling, escalators, and signs are not included in the cost.

Rank 1 for light built-up roof, exposed deck, concrete, adequate lighting and plumbing.

Rank 2 for light built-up roof, exposed deck, carpet and vinyl, planters, adequate lighting and plumbing.

Rank 3 for good built-up roof, parapets, plaster or drywall ceilings, pavers and terrazzo, planters, good lighting and plumbing.

Rank 4 for high-cost roof, parapets, domed skylights, plaster or drywall ceilings, pavers and terrazzo, planters, special lighting and plumbing.

MLO OPEN MALL (ADD; SF Concourse Area)

Open air pedestrian concourse between stores. The cost includes paving, lighting, and ornamentation. Stores, kiosks, and signs are not included in the cost.

Rank 1 for concrete, low-cost planters and benches, adequate illumination.

Rank 2 for patterned concrete, planters and benches, good illumination.

Rank 3 for decorative concrete and good pavers, planters and benches, high-quality illumination.

Rank 4 for best pavers, wood decks, varied elevations, high-cost seating and planters, high-quality illumination.

MM INSULATION (ADD; SF Wall Area)

Cost is an average of a number of different types of insulation that can be found in masonry walls (loose mineral pellets, insulation boards or some type of spray-on). Building location and climate should be considered when selecting a rank. The more extreme the climate, the more insulation typically used.

MOH MOBILE HOME (Dollar Amount)

Restrictions: Models 083x, 088x and 089x only

This component is used for permanently affixed mobile homes. Enter the list price of the mobile home from the affidavit of affixture in number of units field.

MOHS SKIRTING, SIMULATED STONE-BRICK PANELS (LF)

A border or edging of simulated stone or brick panels at the base of a mobile home.

MOHU MOBILE HOME / OFFICE, NOT AFFIXED (Dollar Amount)

Restrictions: Models 084-x thru 087-x only

This component is used for mobile homes or mobile offices that are not permanently affixed. Enter the suggested retail selling price of the mobile home / office in the number of units field.

MOHV SKIRTING, VINYL-METAL (LF)

A border or edging of vinyl or metal at the base of a mobile home.

MOTR MOTORIZED SHUTTER OPERATOR (Add; UN Number of Units)

Restrictions: Residential Models Only

Use this component for the additional cost of a motorized operator for a rolling security shutter (component MSEC). Cost includes electric motor, controls, wiring, and all installation costs. Use rank 1 for small windows, rank 2 for typical windows and passage doors, and ranks 3 and 4 for large windows and patio doors.

MP BRICK (SF Wall Area)

Restrictions: Service Station models only

Solid brick masonry wall found in service stations. The cost includes mortar, reinforcement, windows, and pedestrian doors appropriate to the overall building rank. Service bay doors are not included in the cost.

Rank is influenced by:

- Quantity and quality of windows and doors
- Quality of material and workmanship of exterior and interior wall finishes

MQ CONCRETE BLOCK (SF Wall Area)

Restrictions: Service Station models only

Concrete block masonry wall found in service stations. The cost includes mortar, reinforcement, windows, and pedestrian doors appropriate to the overall building rank. Service bay doors are not included in the cost.

Rank is influenced by:

- Quantity and quality of windows and doors
- Quality of material and workmanship of exterior and interior wall finishes

MR CONCRETE, REINFORCED (SF Wall Area)

Thickness Range: 4"–36" Required in miscellaneous field.

A wall constructed of poured-in-place concrete. The reinforcing is usually a bar set in a grid or mat pattern in the form for concrete wall. Forms used for the wall are usually some type of metal or wood panel. The cost includes windows and doors appropriate to the given model and overall building rank.

Rank is influenced by:

- Quantity and quality of windows and doors
- Quality of material and workmanship of exterior and interior wall finishes

MS STEEL PANELS, BLOCK BACKUP (SF Wall Area)

Restrictions: Service Station models only

Concrete block wall with painted steel panel exterior found in service stations. The cost includes supports, windows, and pedestrian doors appropriate to the overall building rank. Service bay doors are not included.

Rank is influenced by:

- Quantity and quality of windows and doors
- Quality of material and workmanship of exterior and interior wall finishes

MSEC ROLLING SECURITY SHUTTERS (SFW Window / Door Area)

Restrictions: Residential Models Only

Metal residential rolling security shutters. Cost includes self-contained housing box, insulated aluminum alloy slats, guide rails, inside manual hand crank, and all installation costs. Use rank 2 for normal assortment of fenestration; lower ranks for many larger than typical openings, and higher ranks for smaller than typical opening sizes. Cost for electric motorized operators may be added by using component MOTR - Motorized Shutter Operator.

MSP STEEL AND GLASS PORCELAINIZED (SF Wall Area)

Restrictions: Service Station models only

Porcelainized steel and glass panel exterior wall found in service stations. The cost includes supports, windows, and pedestrian doors appropriate to the overall building rank. Service bay doors are not included.

Rank is influenced by:

- Quantity and quality of windows and doors
- Quality of material and workmanship of exterior and interior wall finishes

MSR STEEL AND GLASS PAINTED (SF Wall Area)

Restrictions: Service Station models only

Painted steel and glass panel exterior walls found in service stations. The cost includes supports and windows and pedestrian doors appropriate to the overall building rank. Service bay doors are not included.

Rank is influenced by:

- Quantity and quality of windows and doors
- Quality of material and workmanship of exterior and interior wall finishes

MSTR STRAW BALE (SF Wall Area)

An exterior wall made of stacked straw bales and stucco exterior wall finish. Straw bales may or may not be load-bearing depending on construction method. The cost includes straw bales, spikes or rebar supports, exterior stucco with mesh reinforcing, drywall or plaster interior wall finish, and windows and doors appropriate to the given occupancy and overall building rank. There is no need to enter thickness in the miscellaneous field.

Post and beam or pole frame structural support can be added using components DK or DP.

MTA ELEVATOR (SF Area Served)

Restrictions: Shopping Center models only

Elevators or escalators in an enclosed mall (component MLH or MLE). The capacity, speed, and quality of finish should be considered when selecting a rank.

MTT WATER AND ELECTRICAL SERVICE, RECREATIONAL VEHICLE PARK (EA Space)

Minimum electrical service and water for a recreational vehicle space in a park. The cost includes minimum electrical service (15–60 amps) and water hookup.

MTW WATER SERVICE, RECREATIONAL VEHICLE PARK (EA Space)

Water service for a recreational vehicle space in a park. The cost includes water mains and valve connections.

Rank 1 for 2" mains; service to common hydrants and buildings; no trailer hookups.

Rank 2 for 3" mains; 3/4" service; hydrant at each two spaces.

MU CONCRETE AND GLASS PANELS (SF Wall Area)

A curtain wall (non-load-bearing) made of a combination of precast concrete panels and glass. The panels and glass are attached to a metal or concrete frame. The cost includes windows and doors appropriate to the given model and overall building rank.

Rank is influenced by:

- Quantity and quality of windows and doors
- Quality of material and workmanship of exterior and interior wall finishes

MV METAL AND GLASS PANELS (SF Wall Area)

A combination of metal and glass or all glass paneled curtain wall (non-load-bearing) attached to a structural frame. The cost includes areas of glass and doors appropriate to the given model and overall building rank.

Rank is influenced by:

- Quantity and quality of windows and doors
- Quality of material and workmanship of exterior and interior wall finishes

MW STAINLESS STEEL AND GLASS (SF Wall Area)

Stainless steel and glass paneled curtain wall (non-load-bearing) attached to a structural frame. The cost includes areas of glass and doors appropriate to the given model and overall building rank.

Rank is influenced by:

- Quantity and quality of windows and doors
- Quality of material and workmanship of exterior and interior wall finishes

MWA CAR WASH, MASONRY PARTITION (SF Wall-Partition Area)

Restrictions: Car Wash models only

Masonry partition (bay wall) is a self-serve car wash. Wall thickness should be considered when selecting a rank.

MWB CAR WASH, STEEL PARTITION (SF Wall-Partition Area)

Restrictions: Car Wash models only

Steel panel partition (bay wall) in a self-serve car wash.

The gauge of steel should be considered when selecting a rank.

MWC CAR WASH, WOOD FRAME-STUCCO (SF Wall-Partition Area)

Restrictions: Car Wash models only

Wood frame with siding or stucco partition wall (bay wall) in a self-serve car wash. Cost includes sheathing.

Rank is influenced by:

- Spacing of studs
- Thickness of sheathing
- Quality and type of wall cover

MX BRONZE AND GLASS (SF Wall Area)

A combination of bronzed finished panels and glass curtain wall (non-load-bearing) attached to a structural frame found in higher quality buildings. Cost includes areas of glass and doors appropriate to the given model and overall building rank.

Rank is influenced by:

- Quantity and quality of windows and doors
- Quality of material and workmanship of exterior and interior wall finishes

MY STONE PANELS (SF Wall Area)

Panelized stones such as limestone and granite combined with glass to form higher quality curtain walls (non-load-bearing) attached to a structural frame. These walls are normally found in excellent quality high-rise construction. The cost includes areas of glass and doors appropriate to the given model and overall building rank.

Rank is influenced by:

- Quantity and quality of windows and doors
- Quality of material and workmanship of exterior and interior wall finishes

MYC MARBLE PANEL (SF Wall Area)

A curtain wall (non-load-bearing) with marble panel exterior combined with glass and an interior wall finish attached to a structural frame. Cost includes fasteners, drywall or plaster interior finish, and areas of glass and doors appropriate to the given model and overall building rank.

Rank is influenced by:

- Quantity and quality of windows and doors
- Quality of material and workmanship of exterior and interior wall finishes

MYD SYNTHETIC PLASTER ON RIGID INSULATION (SF Wall Area)

Steel stud curtain wall (non-load-bearing) with synthetic plaster on rigid insulation exterior combined with glass and an interior wall finish attached to a structural frame. The cost includes studs, mesh reinforcing, drywall or plaster interior finish, and areas of glass and doors appropriate to the given model and overall building rank.

Rank is influenced by:

- Quantity and quality of windows and doors
- Quality of material and workmanship of exterior and interior wall finishes

MYG MASONRY AND GLASS PANEL (SF Wall Area)

Steel stud curtain wall (non-load-bearing) with brick or tile veneer exterior combined with glass and an interior wall finish attached to a structural frame. Cost includes studs, sheathing, drywall or plaster interior finish, and areas of glass and doors appropriate to the given model and overall building rank.

Rank is influenced by:

- Quantity and quality of windows and doors
- Quality of material and workmanship of exterior and interior wall finishes

MYH WOOD AND GLASS PANEL (SF Wall Area)

A steel stud curtain wall (non-load-bearing) with wood siding or aggregate stone on plywood sheathing exterior combined with glass, and an interior wall finish attached to a structural frame. Cost includes drywall or plaster interior finish and glass areas and doors appropriate to the given model and overall building rank.

Rank is influenced by:

- Quantity and quality of windows and doors
- Quality of material and workmanship of exterior and interior wall finishes

MZ CLAY TILE (SF Wall Area)

Thickness Range: 4"–36" Required in miscellaneous field.

Clay tile produced in various thicknesses. Lower cost ranks are used for curtain walls and higher ranks are used for load-bearing or partially bearing walls. The cost includes mortar, reinforcing (where necessary), and windows and doors appropriate to the given model and overall building rank.

If the tile is glazed, the component MAB must be used with this component.

Rank is influenced by:

- Quantity and quality of windows and doors
- Quality of material and workmanship of exterior and interior wall finishes

MZB OFFICE MEZZANINE (SF Mezzanine Area)

An enclosed mezzanine with drywall or plaster partitions used as office space. The cost includes structural floor, partitions, floor cover, soffit finish, and typical office lighting, plumbing, railing, and stairs.

MZC STORAGE MEZZANINE (SF Mezzanine Area)

A complete unfinished mezzanine used as a light storage area. The cost includes structural floor, floor and soffit finish, minimum lighting, railing, and stairs.

MZD OPEN MEZZANINE (SF Mezzanine Area)

Restrictions: May not be used with single family home or motel

A complete mezzanine without partitions. The cost includes structural floor, floor and soffit finish, typical lighting, railing, and stairs.

MZH STORAGE MEZZANINE, HEAVY STRUCTURE (SF of Mezzanine Area)

A complete unfinished mezzanine used as a heavy storage area. The cost includes structural floor, floor and soffit finish, minimum lighting, railing, and stairs.

MZM DISPLAY MEZZANINE (SF Mezzanine Area)

A complete mezzanine used as a display area in a retail store. The cost includes structural floor, floor and soffit finish, typical store lighting, plumbing, railing, and stairs.

NAA STEEL STAIRWAY (EA Riser)

Stairs constructed of steel framing and steel or aluminum grate treads. Cost includes a prorated allowance for rails and landing.

Stairway design should be considered when selecting a rank.

NBA WOOD STAIRWAY (EA Riser)

Stairs constructed of wood framing and wood treads. Cost includes a prorated allowance for rails and landing.

Stairway design should be considered when selecting a rank.

NCA FIRE ESCAPE (EA)

A 2-story fire escape with a ladder to the roof (use **NCB** for additional flights).

Fire escapes constructed of some type of steel frame that is affixed to the side wall of a building. Treads are metal and there may be no risers. Landings made of metal grating are typically at each floor level.

NCB FIRE ESCAPE, ADDITIONAL FLIGHTS (EA Flight)

Use this component with **NCA** (Fire Escape) for each additional flight over the base of two.

NDA CONCRETE STAIRWAY (EA Riser)

Stairs constructed of poured-in-place or precast concrete supports and treads. Cost includes a prorated allowance for rails and landing.

Stairway design should be considered when selecting a rank.

NEA CONCRETE AND STEEL STAIRWAY (EA Riser)

Stairs constructed of a steel frame with poured-in-place steel pan or precast concrete treads. Cost includes a prorated allowance for rails and landing.

Stairway design should be considered when selecting a rank.

NG BASEMENT GARAGE DOOR (EA)

An overhead garage door to a basement garage. The cost includes track and fixtures.

The size of the door should be considered when selecting a rank.

Rank 1	9' X 7' uninsulated
Rank 2.5	16' X 7' uninsulated
Rank 2.5	9' X 7' insulated'
Rank 4	16' X 7' insulated

NH CHURCH BASEMENT, CLASSROOM, OFFICES (SF Basement Area)

Restrictions: Church models only

Interior construction component for a church basement with an interior finish that makes it suitable for use as classrooms and offices.

Partitions are either wood or steel stud. Finish on the partitions may be either gypsum board (drywall), plaster or some type of paneling, wallpaper, or paint. Cost includes miscellaneous cabinets, shelves, stairs, and other interior items.

NJ CHURCH BASEMENT, RECREATION (SF Basement Area)

Restrictions: Church models only

Interior construction component for a church basement with an interior finish that makes it suitable for use as a recreational area.

Partitions are either wood or steel stud. Finish on the partitions may be either gypsum board (drywall), plaster or some type of paneling, wallpaper, or paint. Cost includes miscellaneous cabinets, shelves, stairs, and other interior items.

NK CHURCH BASEMENT, DINING HALL, KITCHEN (SF Basement Area)

Restrictions: Church models only

Interior construction component for a church basement with an interior finish that makes it suitable for use as a dining hall and kitchen.

Partitions are either wood or steel stud. Finish on the partitions may be either gypsum board (drywall), plaster or some type of paneling, wallpaper, or paint. Cost includes miscellaneous cabinets, shelves, stairs, and other interior items. Cost does not include kitchen equipment or plumbing.

NL CHURCH BASEMENT, UNFINISHED (SF Basement Area)

Restrictions: Church models only

Interior construction component for the interior of a church basement that has no finish except for incidental partitions and storage shelves.

NO BASEMENT, FINISHED (SF Basement Area)

Basement interior construction that resembles an interior similar to the HA or HB for the occupancy and cost rank chosen, but with a somewhat lesser cost since it is generally less elaborate. This includes interior partitioning and any cabinet work or counter space that might be considered part of the model finish.

NP BASEMENT, PARTIALLY FINISHED (SF Basement Area)

Basement interior construction that contains an amount of partitioning, built-ins, etc., between finished (NO) and unfinished (NQ).

NQ BASEMENT, UNFINISHED (SF Basement Area)

The interior construction component for a basement that has no finish except for incidental partitions and storage shelves commensurate with the model. Alternate components are (NO) for finished basements and (NP) for partially finished basements.

NR BASEMENT, PARKING (SF Basement Area)

Interior construction for parking basement with partitions for elevator shafts, stairwells, and minimal attendant facilities. The partitions may be either gypsum board (drywall) or plaster on a wood or steel stud frame. Cost

includes parking bumpers and lighting but does not include walls, ceiling or ventilation, or additional wall or ceiling finishes.

NS BASEMENT STAIRS, OPEN (EA Flight)

Restrictions: Residential models only

Wood stairs with no risers. The treads rest on the stringers and center carriage.

NT BASEMENT STAIRS, ENCLOSED (EA Flight)

Restrictions: Residential models only

Wood stairs that have risers between treads. This gives the stairway an enclosed appearance.

NX BASEMENT, ELECTRICAL, FINISHED (SF Basement Area)

Includes all costs associated with the basement electrical system, including power service, wiring, outlets, and fixtures.

NY BASEMENT, ELECTRICAL, PARTIALLY FINISHED (SF Basement Area)

Cost for electrical work in a partially finished basement.

NZ BASEMENT, ELECTRICAL, UNFINISHED (SF Basement Area)

Electrical costs for basement area that is unfinished. Cost includes wiring and minimal lighting fixtures.

OB STOREFRONT WITHOUT DISPLAY AREAS (SF Storefront Area)

This component is typically found in department and retail stores. The cost includes ornamentation, bulkhead walls, lighting, and entrance doors.

Enter the square feet of the storefront.

The cost rank of the storefront may be different from that of the building.

OD STOREFRONT WITH DISPLAY AREAS (SF Storefront Area)

This component is typically found in department and retail stores. The cost includes ornamentation, bulkhead walls, lighting, display platforms, ceilings, backs, vestibule, and entrance doors.

The cost rank of the storefront may be different from that of the building.

Enter the square feet of the storefront.

ODF OVERHEAD DOOR, FIBERGLASS (SF Door Area)

Restrictions: Service Station models only

Fiberglass overhead door for service station bay. The cost includes the track.

Rank is influenced by the quality and thickness of the fiberglass and the number of window panels.

ODG STEEL GATE (SF Gate Area)

Restrictions: Service Station models only

Steel gate door for service station only. Cost includes the supports.

ODS OVERHEAD DOOR, STEEL (SF Door Area)

Restrictions: Service Station models only

Steel overhead door for service station only. Cost includes the track.

Rank is influenced by the quality and thickness of the materials and the number of window panels.

ODW OVERHEAD DOOR, WOOD (SF Door Area)

Restrictions: Service Station models only

Wooden overhead door for service station bay. Cost includes the track.

Rank is influenced by the quality and thickness of the wood and the number of window panels.

OG INTERIOR MALL FRONTS (SF Storefront)

Interior mall fronts for stores in enclosed malls. The cost includes glass, closure, bulkhead, sign area, and ornamentation.

Rank is influenced by design, extent of ornamentation, and quality of workmanship.

PA	BRICK FACE, SPLIT (ADD; SF Ornamented Area)
	A split-face brick (Roman or Norman) typically applied as a special feature to an entrance or front elevation. Costs are for the veneer facing only.
PAC	CURBING, ASPHALT (LF)
	A raised margin or edge of a street or paved area.
	Rank is influenced by job size and height, and width of berm or formed curb.
	Rank 1 for a 4-inch rolled berm. Rank 4 for a 6-inch formed curb.
PACM	CURBING, ASPHALT (LF)
	Restrictions: Model 281-x only
	A raised margin or edge of a street or paved area.
	Rank is influenced by job size and height, and width of berm or formed curb.
	Rank 1 for a 4-inch rolled berm. Rank 4 for a 6-inch formed curb.
PAS	PAVING, ASPHALT (SF Paved Area)
	Cost includes consideration for asphalt paving, base, and some parking lot striping. The base material most commonly used is gravel. Thickness of both the asphalt and the base material varies.
PASC	PAVING, ASPHALT, HEAVY COMMERCIAL (SF Paved Area)
	Asphalt paving for streets and areas that have heavy truck traffic. Cost includes grading, asphalt, and a gravel base.
PASL	PAVING, ASPHALT, PARKING LOT (UN - Each Space)
	Costs for each space include engineering (plans, survey, permits, etc.) rough and finished grading, drainage, base, asphalt paving for spaces, drives, and pavement striping. Use for parking lots over 270 spaces or 90,000 square feet.

PASM PAVING, ASPHALT (SF Paved Area)

Restrictions: Model 281x only
Cost includes consideration for asphalt paving and the base. The base material most commonly used is gravel. Thickness of both the asphalt and the base material varies.

PC BRICK, FACE (ADD; SF Ornamented Area)

Full-size face brick typically applied as a special feature to an entrance or front elevation. Costs are for the veneer facing only.

PCC CURBING, CONCRETE (LF)

The raised edge of a street or paved area that is formed and poured by hand, or formed using a curbing machine.

Rank is influenced by job size, height or curb, and presence of integral gutter.

Rank 1 if the curb is rolled with no gutter.
Rank 4 if the curb is 8 inches with a 2-foot gutter.

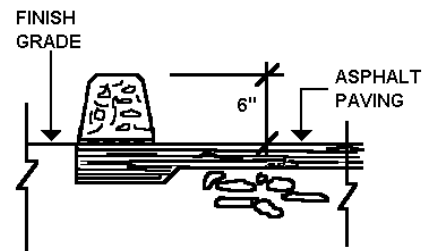

PCCM CURBING, CONCRETE (LF)

Restrictions: Model 281x only
The raised edge of a street or paved area that is formed and poured by hand or formed using a curbing machine.
Rank is influenced by job size, height or curb, and presence of integral gutter.

Rank 1 if the curb is rolled with no gutter.
Rank 4 if the curb is 8 inches with a 2-foot gutter.

PCD DECORATIVE FINISH, PAVED AREAS (ADD; SF Paved Area)

Use this component for the added cost of a decorative finish on concrete pavement, including pool decking (PCO and PCU).

Rank 1 for color or salt finish.
Rank 2 for stamped pattern, exposed aggregate, brick ribbons or trim.
Rank 3 for epoxy with stone or shell cover.

NOTE: Use ranks 3 and 4 for small areas, or where additional excavation and long hauls are required.

PCI CONCRETE ISLANDS (SF of Island)

Restrictions: Service Station models only

A concrete pad approximately 4 feet wide raised above ground level to support dispensers and service equipment.

The cost includes concrete, forming, concrete finishing, and painting.

Rank is influenced by length and thickness.

PCM PARKING COVER, METAL (SF Cover)

A freestanding metal canopy supported by double columns or cantilevered from a single column. These structures are usually found near commercial buildings or at airports and are used to cover vehicles or aircraft.

Cost includes roof support structure, footings, and roof cover.

Cost does not include paving, walls, or lighting.

Rank 1 for double-pole columns approximately 7 feet high.

Rank 2 for a tee or semi-cantilever approximately 7 feet high.

Rank 3 for full cantilever approximately 7 feet high.

Rank 4 for an approximately 12-feet-high structure.

PCMG MULTIPLE PARKING COVER, METAL (SF Cover)

A freestanding metal canopy supported by double columns or cantilevered from a single column. These structures are usually found near commercial buildings or at airports and are used to cover vehicles or aircraft. Use for sites with 10 or more parking cover spaces.

Cost includes roof support structure, footings, and roof cover.

Cost does not include paving, walls, or lighting.

Rank 1 for double-pole columns approximately 7 feet high.

Rank 2 for a tee or semi-cantilever approximately 7 feet high.

Rank 3 for full cantilever approximately 7 feet high.

Rank 4 for an approximately 12-feet-high structure.

PCO PAVING, CONCRETE, REINFORCED (SF Paved Area)

Concrete paving that generally has some type of reinforcing, usually mesh, for a concrete pad or open areas of a parking lot, streets, and heavy truck traffic areas. Cost includes grading, concrete, and a gravel base.

Use lower ranks for light reinforced concrete areas and the higher ranks for heavily reinforced concrete areas.

PCU PAVING, CONCRETE, UNREINFORCED (SF Paved Area)

Concrete paving for slabs, sidewalks, drives, and parking lots. Cost includes grading, concrete, and a gravel base. The cost does not include reinforcing (mesh or bars).

Use lower ranks for areas over 3,000 square feet, and higher ranks for areas under 3,000 square feet.
Use PCO for street paving and areas that have heavy truck traffic.

PCUM PAVING, CONCRETE, UNREINFORCED (SF Paved Area)

Restrictions: Model 281x only

Concrete paving for slabs, sidewalks, and drives. The cost does not include reinforcing (mesh or bars).

PD BRICK, SELECT COMMON (ADD; SF Ornamented Area)

Standard size, better quality, unglazed brick, typically applied as a special feature to an entrance or front elevation. Costs are for the veneer facing only.

PE BRICK, USED (ADD; SF Ornamented Area)

Common brick previously used and usually discolored from its original red clay appearance. Applied as a special feature to an entrance or front elevation. Costs are for the veneer facing only.

PEA BRICK, SIMULATED VENEER (ADD; SF Ornamented Area)

A thin wall covering that has the appearance of brick. Applied as a special feature to an entrance or front elevation. Costs are for the veneer facing only.

PFA GLASS BLOCK, WHITE (ADD; SF Ornamented Area)

Manufactured hollow blocks of white, clear, or aqua glass. Applied as a special feature to an entrance or front elevation. Costs are for the veneer facing only.

PFB GLASS BLOCK, COLORED (ADD; SF Ornamented Area)

Manufactured hollow blocks of colored or reflective glass. Applied as a special feature to an entrance or front elevation. Costs are for the veneer facing only. The blocks admit light and insulate against the passage of sound. They are put together with mortar joints to form ornamental walls.

PG CONCRETE BLOCK, IMITATION FLAGSTONE (ADD; SF Ornamented Area)

Concrete block cast in irregular shapes to give it a flagstone appearance. Applied as a special feature to an entrance or front elevation. This component is for the veneer facing only.

PH CONCRETE BLOCK, SCREEN (ADD; SF Ornamented Area)

Concrete block units in which the internal structure of the block is open or hollow. When the units are laid in a wall, the shaped holes create a decorative screenlike effect. Applied as a special feature to an entrance or front elevation. Costs are for the veneer facing only.

PI CONCRETE BLOCK, ORNAMENTAL FACE (ADD; SF Ornamented Area)

A decorative concrete block, applied as a special feature to an entrance or front elevation. Costs are for the veneer facing only.

Rank 1 for slump stone.
Rank 2 for a fluted concrete block.
Rank 3 for split face.
Rank 4 for ground face.

PJ GRANITE (ADD; SF Ornamented Area)

A very hard stone that is usually cut into slabs or blocks and will take a high polish. Applied as a special feature to an entrance or front elevation. Costs are for the veneer facing only.

PK LIMESTONE (ADD; SF Ornamented Area)

A soft stone, typically laid in an ashlar facing, applied as a special feature to an entrance or front elevation. Costs are for the veneer facing only.

PL MARBLE (ADD; SF Ornamented Area)

A very hard rock (generally limestone) that is usually cut into tiles, blocks, or slabs, and is highly polished. Applied as a special feature to an entrance or front elevation. Costs are for the veneer facing only.

PM METAL SCREEN (ADD; SF Ornamented Area)

Decorative metal latticework or solid panels and louvers found in various shapes and sizes. The metal may be a number of different types (aluminum, copper, steel). Costs are for the panels only.

PNA STONE, SIMULATED (ADD; SF Ornamented Area)

A lightweight wall covering that has the appearance of local stone. Applied as a special feature to an entrance or front elevation. Costs are for the veneer facing only.

PO STONE VENEER, LOCAL (ADD; SF Ornamented Area)

A soft local stone, typically sandstone, laid in an ashlar facing. Applied as a special feature to an entrance or front elevation. Costs are for the veneer facing only.

POA AWNING, METAL (SF Awning)

A complete metal awning structure most commonly found in conjunction with mobile home and residential improvements. May be used as a cover over an entrance or carport.

Costs include roof structure, posts, and beams.

POD AWNING, WOOD, INCLUDES COVER (SF Awning)

A complete wood roof structure with wood joists and board or plywood sheathing. Most commonly found in conjunction with mobile home and residential improvements. May be used as a cover over an entrance or carport.

Costs include roof structure, roof cover, posts, and beams.

POR PORCH-PATIO, CONCRETE SLAB WITHOUT STEPS (SF)

This component includes an open concrete slab without steps, all supporting posts and beams, wood joists and wood deck, and composition rolled roofing.

PORE PORCH, ENCLOSED (SF)

An enclosed porch primarily found in conjunction with residential improvements. Costs include walls, roof structure and cover, concrete floor, and supporting posts and beams.

Rank 1 for all screen enclosed.

Rank 2 for half screen and half frame or masonry enclosed.

Rank 3 for half glass and half frame or masonry enclosed.

Rank 4 for all glass enclosed.

POS AWNING, SLATTED-LOUVERED (SF Awning)

A complete wood roof structure with slatted or louvered design. Most commonly found in conjunction with mobile home and residential improvements to provide shade.

Costs include roof structure, posts, and beams.

POT PORCH-PATIO, CONCRETE SLAB WITH STEPS (SF)

This is an open porch or patio with steps. The price includes the supporting posts, the roof structure, and the roof covering.

POTE PORCH-PATIO WITH STEPS, ENCLOSED (SF)

An enclosed porch primarily found in conjunction with residential improvements. Costs include walls, roof structure and cover, concrete floor, and supporting posts and beams.

POW PORCH-PATIO, WOOD DECK WITH STEPS (SF)

Size Range: 10-2,000 SF

This component includes wood deck with steps, all supporting posts and beams, wood joists and wood deck, and composition rolled roofing.

POWE WOOD DECK WITH STEPS AND ROOF, ENCLOSED (SF)

Size Range: 10–2,000 SF

An enclosed porch primarily found in conjunction with residential improvements. Costs include walls, roof structure and cover, wood floor, and supporting posts and beams.

POX PORCH–PATIO, WOOD DECK WITHOUT STEPS (SF)

Size Range: 10–2,000 SF

This component includes wood deck without steps, all supporting posts and beams, wood joists and wood deck roof structure, and composition rolled roofing.

**POXE WOOD DECK AND ROOF WITHOUT STEPS,
ENCLOSED (SF)**

Size Range: 10–2,000 SF

An enclosed porch primarily found in conjunction with residential improvements. Costs include walls, roof structure and cover, wood floor, and supporting posts and beams.

**PP STONE VENEER, RUBBLE (ADD; SF Ornamented
Area)**

A local fieldstone laid in an irregular pattern or course. Applied as a special feature to an entrance or front elevation. Costs are for the veneer facing only.

PR SLATE (ADD; SF Ornamented Area)

A hard blue-gray or black stone cut into thin tiles or shapes. Applied as a special feature to an entrance or front elevation. Costs are for the veneer facing only.

PS STUCCO ON MASONRY (ADD; SF Ornamented Area)

Stucco finish applied over a structural masonry wall as a special feature to an entrance or front elevation. Costs are for the finish only.

PT TERRA COTTA (ADD; SF Ornamented Area)

The structural characteristics of terra cotta are very similar to brick. It is molded clay that is typically fired. It may be glazed to produce a particular color or finish. The shapes are molded either by hand or machine, and are applied as a special feature to an entrance or front elevation. Costs are for the veneer facing only.

Rank is influenced by:

—Intricacy of design and quality of workmanship

-
- PU TILE, CERAMIC (ADD; SF Ornamented Area)**
- Glazed-surface tile applied as a special feature to an entrance or front elevation. Costs are for the veneer facing only.
- PV TILE, MOSAIC (ADD; SF Ornamented Area)**
- Small ceramic tile with glazed or unglazed exposed surface, excluding pictorial artwork. Applied as a special feature to an entrance or front elevation. Costs are for the veneer facing only.
- PW VITROLITE (ADD; SF Ornamented Area)**
- Opaque structural glass in a metal frame. Applied as a special feature to an entrance or front elevation. Costs are for the glass panels only.
- PX TEXTURED PLYWOOD (ADD; SF Ornamented Area)**
- Decorative sheet siding attached to masonry wall as a special feature to an entrance or front elevation. Costs are for the veneer facing only.
- PY CEDAR ON MASONRY (ADD; SF Ornamented Area)**
- Cedar siding on a masonry wall as a special feature to an entrance or front elevation. Costs are for the veneer facing only.
- PZ REDWOOD ON MASONRY (ADD; SF Ornamented Area)**
- Redwood decorative siding on a masonry wall as a special feature to an entrance or front elevation. Costs are for the veneer facing only.

QA CONCRETE JOISTS, SLAB (SF Roof Area)

Poured-in-place concrete joists and roof deck, reinforced with a bar. Cost does not include roof cover.

Size of the joists and slab thickness should be considered when selecting a rank.

QAA WOOD JOISTS, WOOD DECK (SF Roof Area)

Wood joists with either a board or plywood sheathing. This includes prefabricated residential trussed rafters and joists.

Cost does not include roof cover.

Size of the joists and deck thickness should be considered when selecting a rank.

For monitor or sawtooth design, use "M" or "S" suffix.

QAB LONG SPAN GIRDERS (SF Roof Area)

A steel roof support system that is constructed of a series of structural steel members that are usually not more than 36" in depth. They are found in buildings where long clear spans are required. Additional depths can be utilized if cover plates are used for added strength (either welded or riveted). Generally the trusses or girders are included as the horizontal members in the complete frame components. In certain cases, a low frame cost could be used to account for just the vertical portions. This component could then be used for the horizontal supports.

Cost does not include vertical supports, roof deck, or roof cover.

QAC FALSE MANSARD FASCIA, METAL FRAME-WOOD SHEATHING (SF Fascia)

Steel stud and channel frame with wood sheathing to form a false mansard fascia.

The roof cover is not included.

Rank is influenced by size, extent of projections, and design.

QAD FALSE MANSARD FASCIA, WOOD FRAME-WOOD SHEATHING (SF Fascia)

Wood stud and strip frame with wood sheathing to form a false mansard fascia.

The roof cover is not included.

Rank is influenced by size, extent of projections, and design.

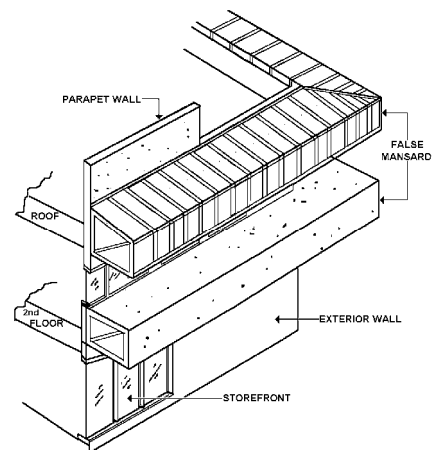

QAE CONCRETE PLANK ON BEARING WALL (SF Roof Area)

Precast concrete plank roof resting on bearing walls.
 Roof cover is not included.

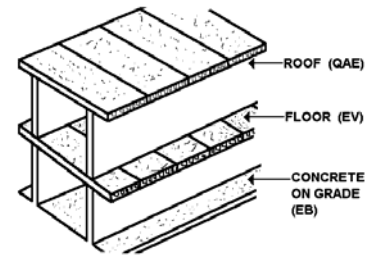

QAF WOOD JOISTS, PREFABRICATED PANELS (SF)

Prefabricated wood sheathing panels on light wood joists used with glu-lam construction. The cost includes panel members and ancillary fasteners only.

The roof cover is not included in the cost.

QBA METAL ATRIUM FRAME AND GLAZING (SF Roof Area)

Metal frame and glazing for major skylight atrium areas. The cost includes glazing and ancillary items. Architectural space frame is not included in the cost. Use component QXA for decorative space frame.

Rank is influenced by composition and treatment of frame and glazing and pitch of the surface.

QC PRECAST JOISTS AND DECK (SF Roof Area)

Both joists and deck are cast off site and transported to the site. The joists may be cast and installed independent of the deck, or they may be one integral system. Both joists and deck are typically reinforced and are usually erected by a crane, placed side by side, aligned, and leveled. The keyways are usually grout-filled.

Cost does not include roof cover.

The size and thickness of the joists and deck should be considered when selecting a rank.

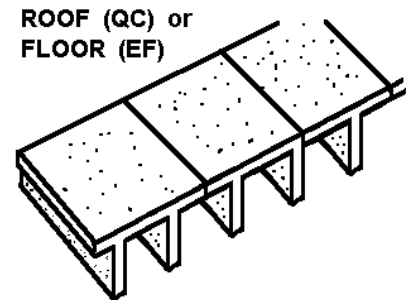

QCA TONGUE AND GROOVE, EXPOSED RAFTERS (SF Roof Area)

Roof structure is also the interior ceiling finish of the floor area directly below. The supporting frame may be large timber members that are either finished or left natural. The sheathing is tongue-and-groove boards, either 1 or 2 inches thick by 6 or 8 inches wide.

Roof cover is not included.

QD CONCRETE SLAB (SF Roof Area)

For monitor or sawtooth design, use "M" or "S" suffix.

A concrete slab roof resting on bearing walls or other supports.

Roof cover is not included.

Rank is influenced by the thickness of the slab.

QDA CONCRETE JOISTS, WOOD SHEATHING (SF Roof Area)

Restrictions: Classes C, D, S Only
Garage, Industrial, Farm models only

Roof system consisting of precast concrete joists and wood sheathing.

Cost does not include roof cover.

Rank is influenced by the size and spacing of the joists.

QE CONCRETE, THIN-SHELL (SF Roof Area)

This roof system is used in structures that have large spans and require light roof loads. Commonly it is a cast-in-place concrete, although it can be precast panels. The shell is normally thinner than a typical concrete roof system. The most common type is a cylindrical shell adapted for rectangular-planned structures. The shell is thicker near the supports due to the bending stresses. Based on individual designs, there may be a concrete beam cast integral with the shell to give added rigidity.

Cost does not include roof cover.

QF LAMELLA (SF Roof Area)

Roof frame with planks placed on edge and arranged in a diamond pattern. Typically the planks are short, with the ends of two members carried at the center of a third piece. Such roof structures are commonly erected with labor using a scaffold because a large section must be in place before the supporting characteristic develops. Such roof structures are usually specially designed and detailed by engineers.

Cost does not include roof cover.

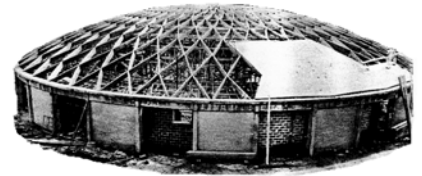

QG STEEL JOISTS, CONCRETE SLAB (SF Roof Area)

The joists are the structural steel framing members that provide strength for this type of roof system. On top of the joists is a concrete slab roof system that has been formed and poured in place. The slab roof is generally reinforced with a bar.

Cost does not include roof cover.

The size and thickness of the joists and deck should be considered when selecting a rank.

QH STEEL JOISTS, GYPSUM (SF Roof Area)

Roof structure has structural steel framing members. The sheathing covering the steel joists is usually fireproofed gypsum covered by fibrous, water-resistant material. Edges are scored to provide a tight fit at the joints.

Cost does not include roof cover.

The size and thickness of the joists and deck should be considered when selecting a rank.

QI STEEL JOISTS, PRECAST PLANK (SF Roof Area)

Over structural steel framing members is a precast concrete plank. The planks come in various thicknesses and dimensions and are usually transported to the site and installed.

Cost does not include roof cover.

The size and thickness of the joists and deck should be considered when selecting a rank.

QJ STEEL JOISTS, STEEL DECK, GYPSUM (SF Roof Area)

On top of the steel structural framing members is placed a steel deck that acts as the roof sheathing. Over the steel deck is poured gypsum or concrete.

Cost does not include roof cover.

The size and thickness of the joists and deck should be considered when selecting a rank.

QK STEEL JOISTS, STEEL DECK (SF Roof Area)

Placed over the structural steel frame is a steel deck. The decking is generally crimped or ribbed, with insulation board placed on top before the cover is applied.

Cost does not include roof cover or insulation board.

The size and thickness of the joists and deck should be considered when selecting a rank.

For monitor or sawtooth design, use "M" or "S" suffix.

QL STEEL JOISTS, COMPOSITION DECK (SF Roof Area)

Over the structural steel frame is a fiberboard decking that can be finished on one side. Typically this type of decking is tongue and grooved for fitting the individual composition sheets.

Cost does not include roof cover.

The size and thickness of the joists and deck should be considered when selecting a rank.

For monitor or sawtooth design, use "M" or "S" suffix.

QM STEEL JOISTS, WOOD DECK (SF Roof Area)

A wood sheathing or deck placed over the structural steel frame that may be solid plywood sheathing, solid board or some type of wood plank.

Cost does not include roof cover.

The size and thickness of the joists and deck should be considered when selecting a rank.

For monitor or sawtooth design, use "M" or "S" suffix.

QO WOOD JOIST, COMPOSITION DECK (SF Roof Area)

Wood joists and fibrous roof sheathing which are water-resistant. Over the deck is the roof cover. This includes prefabricated residential trussed rafters and joists.

Cost does not include roof cover.

The size and thickness of the joists and deck should be considered when selecting a rank.

For monitor or sawtooth design, use "M" or "S" suffix.

QRSW WOOD ROOF SHEATHING (SF Roof Area)

Use this component to add wood roof sheathing to structural components that do not include sheathing or decking in their cost. The cost includes material and labor for sheathing only. Use:

Rank 1 for 1/2" plywood
Rank 2 for 5/8" plywood
Rank 3 for 1" solid board
Rank 4 for 1" tongue & groove

QS OPEN STEEL SYSTEM FOR CORRUGATED METAL (SF Roof Area)

Consists of structural steel members, usually beams and channels acting as purlin support system. The system is covered with a corrugated metal roof cover.

Cost does not include sheathing, vertical column supports, or roof cover.

The size and spacing of the structural members should be considered when selecting a rank.

For monitor or sawtooth design, use "M" or "S" suffix.

QSA OPEN STEEL SYSTEM, LIGHT PURLIN SUPPORTS (SF Roof Area)

Light steel flanges or channels used to support a corrugated metal roof cover in light pre-engineered steel frame construction.

Cost does not include roof cover or skeleton steel frame.

The size and spacing of the structural members should be considered when selecting a rank.

QT OPEN WOOD SYSTEM FOR CORRUGATED METAL (SF Roof Area)

Consists of the secondary wood members, usually purlins, which support a corrugated metal roof. This type of roof system is normally found in open wood trusses or post and beam Class C and D structures.

For monitor or sawtooth design, use "M" or "S" suffix.

QTA OPEN WOOD SYSTEM, LIGHT PURLIN SUPPORTS ONLY (SF Roof Area)

Light wood strips used to support a corrugated metal roof cover in wood pole frame construction.

Cost does not include roof cover or wood trusses.

Rank is influenced by the size and spacing of the strips.

QU STEEL TRUSSES (SF Roof Area)

Framework is a structural steel design formed in a series of rigid triangles. They can be used on either a flat or a pitched roof and typically are used in structures requiring a long clear span. Generally the trusses or girders are included as the horizontal members in the complete frame components. In certain cases, a low frame cost could be used to account for just the vertical portions. This component would then be used for the horizontal supports.

Cost does not include vertical column supports, sheathing or a roof cover.

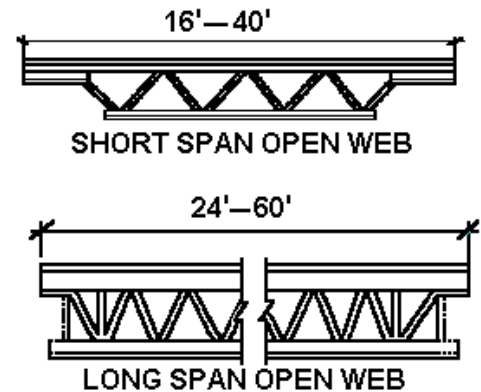

QV TIMBER TRUSSES (SF Roof Area)

Composed of timber beams connected with gussets at the chords and diagonal bracing to the main structural timber. Depending on the design of the truss, the bottom chord may carry the ceiling. Typically, the advantage of this type of roof support system is that it is rapidly erected and can carry long clear spans with the structural support being provided in the exterior wall. In certain cases, a low frame cost could be used to account for just the vertical portions. This component would then be used for the horizontal supports. The cost for lightweight trusses used in residential construction is included in roof structure components QAA, QCA, and QO.

Cost does not include vertical supports, sheathing, or roof cover.

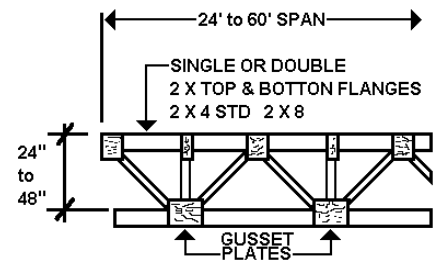

QW GLUE LAMINATED GIRDERS (SF Roof Area)

Composed of a number of individual pieces of wood laminated together at extreme pressure. Generally the trusses or girders are included as the horizontal members in the complete frame components. In certain cases, a low frame cost could be used to account for just the vertical portions. This component would then be used for the horizontal supports.

The cost does not include vertical supports, sheathing, or a roof cover.

QWA CAR WASH, STEEL (SF Roof Area)

Restrictions: Car Wash models only

Steel roof on a self-serve car wash. The cost includes frame, finished cover or deck, and lighting.

Rank is influenced by:

- Gauge of steel
- Durability of framing
- Extent of ornamentation

QWB CAR WASH, WOOD (SF Roof Area)

Restrictions: Car Wash models only

Wood frame roof on a self-serve car wash. The cost includes frame, deck, cover, and lighting.

Rank is influenced by:

- Spacing of rafters
- Thickness of sheathing
- Quality of roof cover
- Parapet and ornamentation

QX STEEL SPACE FRAME (SF Roof Area)

Usually composed of an open three-dimensional steel frame in which the framing members have been welded together. The steel is typically lightweight and, because of its configuration, allows for the passage of electrical, plumbing lines and heating or cooling ductwork. The cost includes sheathing.

Cost does not include roof cover or any vertical supports.

QXA ARCHITECTURAL SPACE FRAME (SF Roof Area)

A three-dimensional trusslike decorative frame used to span a rectangular area, generally atriums. Cost does not include any glazing, sheathing, roof cover, or vertical supports.

Use component QBA for atrium skylight glazing.

Rank is influenced by composition, treatment, and pitch of the frame.

QY MARQUEE, WOOD FRAME (SF Marquee Area)

This is the cantilevered portion of the building over an entrance that is constructed with a wood frame. Costs include a completely finished structure, but not vertical supports or any electrical components.

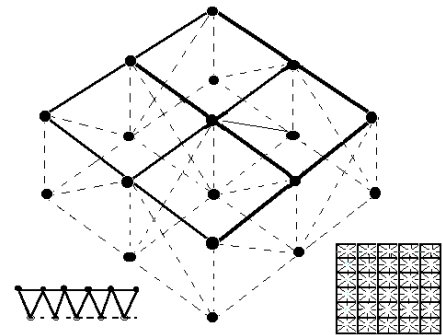

The size of the marquee, distance that is cantilevered, and amount of finish and ornamentation should be considered when making the cost rank selection.

Rank 1 for metal finish, plain.
Rank 4 for ornate metal finish.

QYC CANOPY, WOOD FRAME (SF Canopy Area)

This is the cantilevered portion of a building that extends over an entrance. The wood frame may or may not have vertical wood supports. Cost includes wood structure with minimum soffit finish and roof cover.

The distance from the building and structural design of the canopy should be considered when selecting a rank.

QYD CANOPY, MANSARD, WOOD FRAME (SF Canopy)
QYE CANOPY, WOOD FRAME (SF Canopy)

Refer to last page in this section for description and drawing.

QYR RAMADA (SF)

A roofed shelter that may or may not be attached to the primary structure.

Cost includes roof structure, roof cover, and supporting posts and beams.

QYRM RAMADA, MINIMUM GRADE (SF)

A roofed shelter of minimum grade that may or may not be attached to the primary structure.

Cost includes roof structure, roof cover, supporting posts, and beams.

QZ MARQUEE, STEEL FRAME (SF Marquee Area)

This is the cantilevered portion of the building over an entrance that is constructed with a steel frame.

The size of the marquee and distance that is cantilevered should be considered when making the cost rank selection.

QZC CANOPY, STEEL FRAME (SF Canopy Area)

This is the cantilevered portion of a building that extends over an entrance. The steel frame may or may not have vertical steel supports. Cost includes steel structure with minimum soffit finish and roof cover.

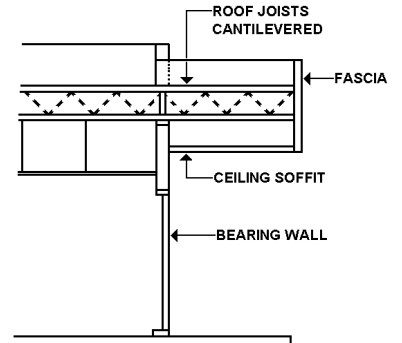

The distance from the building and structural design of the canopy should be considered when selecting a rank.

QZD CANOPY, MANSARD, METAL FRAME (SF Canopy)

QZE CANOPY, STEEL FRAME (SF Canopy)

Refer to last page in this section for description and drawing.

QYD CANOPY, MANSARD, WOOD FRAME (SF Canopy)

Light false mansard-shaped cover that extends over an entrance of a building. The wood frame may or may not have vertical wood supports. Cost includes wood structure with minimum soffit finish and roof cover.

The distance the canopy extends from the building should be considered when selecting a rank.

QYE CANOPY, WOOD FRAME (SF Canopy)

Including posts and beams, roof structure, sheathing, roof cover, and minimum electric.

QZD CANOPY, MANSARD, METAL FRAME (SF Canopy)

Light false mansard-shaped cover that extends over an entrance of a building. The metal frame may or may not have vertical metal supports. Cost includes metal structure with minimum soffit finish and roof cover.

The distance the canopy extends from the building should be considered when selecting a rank.

QZE CANOPY, STEEL FRAME (SF Canopy)

Including posts and beams, roof structure, sheathing, roof cover, and minimum electric.

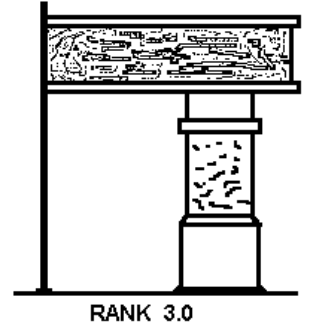
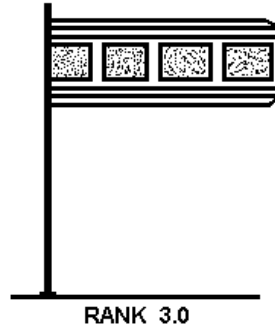
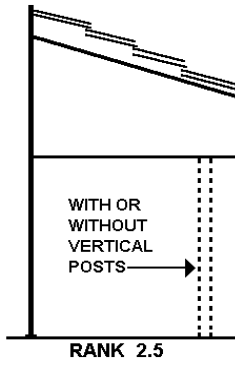
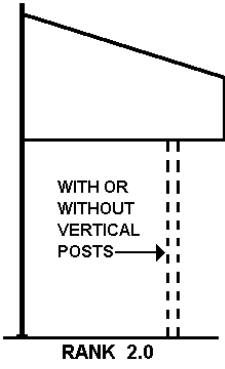
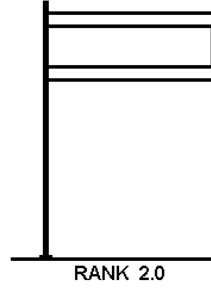
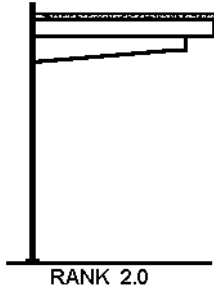
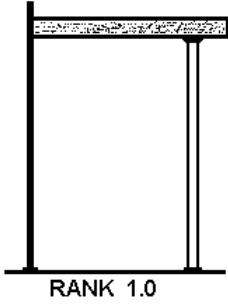

RAA FIBERGLASS SHEETS (SF Roof Area)

Corrugated fiberglass roof cover. The cost includes the appropriate flashing, gutters, fasteners, and openings typical of the model.

Rank is influenced by thickness of material and design of the roof.

RBA METAL SHINGLES (SF Roof Area)

Metal shingle roof cover. Cost includes the appropriate flashing, gutters, fasteners, and openings typical of the model.

Rank is influenced by thickness of material and shape of the roof.

RBB INTERIOR METAL LINER (ADD; SF Roof Area)

Cost adjustment for interior metal roof liner in class C, D, and S buildings. This component is used with component RY, Metal Preformed Sheet Roof Cover.

Rank is influenced by thickness of material and shape of the roof.

RBC PORCELAIN ENAMEL FINISH (ADD; SF Roof Area)

Cost adjustment of porcelain enamel finish on a metal roof.

This component can be used with any of the following:

- RBA Metal Shingles
- RY Metal, Preformed Sheets
- RZ Metal, Formed Seams
- RW Metal Sandwich Panel
- RX Metal Sandwich Panel, Cold Storage

RC ASBESTOS SHINGLE (SF Roof Area)

Applied over pitched roofs. The method of lapping the shingles may also vary. Minimum pitched roofs may be used if there is an underlayment application below the shingles. Cost includes the appropriate flashing, gutters, fasteners, and openings typical of the model.

RCA RAILINGS, CONTROLLED AREA (LF)

Railings and posts erected to provide a physical boundary for a controlled area.

- Rank 1 for chain link.
- Rank 2 for 3/4" nylon rope.
- Rank 3 for 1 3/4" chrome tube.
- Rank 4 for 1 3/4" stainless steel tube.

RD BUILT-UP COMPOSITION (SF Roof Area)

This type of roof cover consists of alternate layers of saturated felt and moppings of pitch or asphalt that may have a top pouring of pitch or asphalt into which gravel may be embedded. This type of roof cover is normally applied over flat-roofed surfaces. Cost includes the appropriate flashing, gutters, fasteners, and openings typical of the model.

Rank is influenced by type of material and installation. Lower ranks are loosely laid; higher ranks are fully adhered.

RE COMPOSITION, ROLL (SF Roof Area)

Composed of asphalt-impregnated felt with a finished top layer of mineral granules, usually installed in long sheets as it is unrolled. The joints will be staggered; widths of the rolls vary. Cost includes the appropriate flashing, gutters, fasteners, and openings typical of the model.

Rank is influenced by type of material and installation. Lower ranks are loosely laid; higher ranks are fully adhered.

RF COMPOSITION SHINGLE (SF Roof Area)

This type of shingle is made of either felt saturated with asphalt and surfaced with mineral granules, or inorganic fiberglass saturated with asphalt and surfaced with ceramic granules. The shingle may be made individually, in strips, interlocking, or self-sealing. Normally this type of roof cover is applied on medium-pitched roofs over building paper. Cost includes the appropriate flashing, gutters, fasteners, and openings typical of the model.

RG CONCRETE TILE (SF Roof Area)

A thin-cast concrete, which is formed into tiles and applied over sloped roofs. It is normally applied over building paper. The tiles are laid in an interlocking pattern and nailed to the roof sheathing. Nail holes are molded in the tile for easy application to the sheathing. Cost includes the appropriate flashing, gutters, fasteners, and openings typical of the model.

For porcelain enamel finish, add component RBC.

RH COPPER (SF Roof Area)

This type of roof is made from copper and copper alloys and may be applied as formed seam sheets or rolls. It is most frequently applied in a flat, standing, or batten seam method. When applied in rolls, the flat seam method has flat locked and soldered joints normally held down with copper cleats. The standing seam method can be applied over sloped roof surfaces with the seams being finished and standing 1 inch high. Normally the seams are unsoldered with the joints being staggered. The spacing of the seams is characteristically a function of the architectural design of the roof. The weight and composition determine the cost rank, with light flat seam copper at the low end and heavy zinc-copper batten seam at the high end.

Cost includes the appropriate flashing, gutters, fasteners, and openings typical of the model.

For porcelain enamel finish, add component RBC.

RJA ELASTOMERIC, SINGLE PLY (SF Roof Area)

Single sheet of rubberlike membrane consisting of several combinations of plastics and synthetic rubber stretched into place as a roof cover. Cost includes the appropriate flashing, adhesive, gutters, gravel stops, fasteners, ballast, and openings typical of the model.

Rank is influenced by type of material and installation. Lower ranks are loosely laid; higher ranks are fully adhered.

RJB ELASTOMERIC, REINFORCED SHEET (SF Roof Area)

Single sheet of heavy-duty, reinforced, rubberlike, layered membrane consisting of several combinations of plastics and synthetic rubber stretched into place as a roof cover. Cost includes the appropriate flashing, adhesive, gutters, gravel stops, fasteners, ballast, and openings typical of the model.

Rank is influenced by type of material and installation. Lower ranks are loosely laid; higher ranks are fully adhered.

RJC ELASTOMERIC, FLUID COAT (SF Roof Area)

A single component liquid or spray applied to the roof surface to yield elastomeric films for high strength waterproof membranes.

Cost includes the appropriate flashing, gutters, fasteners, and openings typical of the model.

RM WOOD SHAKES (SF Roof Area)

Normally installed on a pitched roof over building paper. It is split from a bolt of wood and is generally thicker than a wood shingle.

Cost includes the appropriate flashing, gutters, fasteners, and openings typical of the model.

RN WOOD SHAKES, FIRE-RESISTANT (SF Roof Area)

Shake roof cover that has been chemically treated to inhibit the spread of fire.

Cost includes the appropriate flashing, gutters, fasteners, and openings typical of the model.

RO SLATE (SF Roof Area)

Hard rock, cut into thin tiles or slabs and furnished in a number of sizes, thicknesses, and finishes.

Cost includes the appropriate flashing, gutters, fasteners, and openings typical of the model.

RQ TERNE (SF Roof Area)

A formed steel sheet coated with a lead-tin alloy. Most frequently applied over sloping roof surfaces.

Cost includes the appropriate flashing, gutters, fasteners, and openings typical of the model.

Lower cost ranks are for flat or standing seam. Higher ranks are for batten seam.

RR CLAY TILE (SF Roof Area)

Made primarily from clay (either manufactured or custom made), molded to various shapes and sizes and available in a variety of colors. Most tiles come in interlocking patterns with either end bands or half-tile used on each course to break the joints. It is normally applied over a coated, heavy building paper and the end joints are cemented with an elastic adhesive.

Cost includes the appropriate flashing, gutters, fasteners, and openings typical of the model.

RRS RAILROAD SPUR (LF and Weight)

Restrictions: 30–150 pounds

A short length of railroad track that is usually parallel to a main track. The spur is used for loading, unloading, or storage. The cost includes rails, ties, and ballast.

Linear feet required in miscellaneous value field, and weight of steel required in units of measure field.

Use component RRT for the switch and turnout.

Ranks 1 and 2 for rerailed tracks.
Ranks 3 and 4 for new tracks.

WEIGHT OF RAIL (pounds per yard)	SIZE OF RAIL (base x height)
40	3 1/2 x 3 1/2
60	4 1/4 x 4 1/4
80	5 x 5
100	5 3/8 x 6 5/8
115	5 1/2 x 6 5/8
130	6 x 6 3/4

RRT RAILROAD SPUR, SWITCH AND TURNOUT (ADD; EA and Weight)

Restrictions: 30–150 pounds

Use this component for the added cost of a switch and turnout connected to a railroad spur (RRS).

Each additional switch and turnout required in miscellaneous field, and weight of steel required in units of measure field.

RS TRANSITE (SF Roof Area)

Sheet-type roof cover of dense material made from Portland cement and asbestos fibers combined under pressure. Generally a very heavy and strong roof cover with the individual sheets available in a number of different thicknesses.

Cost includes the appropriate flashing, gutters, fasteners, and openings typical of the model.

RT WOOD SHINGLES (SF Roof Area)

Wood cover that is a thin, small, generally uniform unit, split from a block of wood. It is laid in horizontal overlapping layers on a pitched roof system. Joints typically are staggered.

Cost includes the appropriate flashing, gutters, fasteners, and opening typical of the model.

RTA WOOD FIBER SHINGLES (SF Roof Area)

A hardboard cover made of a thin, uniform, pressed wood fiber panel. The panel simulates natural wood shingles in texture and color and is laid in horizontal overlapping layers on a pitched roof system. The cost includes flashings, gutters, fasteners, and openings typical of the occupancy.

RU INSULATION (ADD; SF Roof Area)

Use this component for the added cost of roof insulation (e.g., fiberglass batt, blanket insulation, or some type of insulation board). The costs are averages of a number of different kinds, with the high ranks being predominantly board stock material.

Rank selection should consider that climate has an influence on the thickness and therefore the cost of the insulation used.

RV PLASTIC TILE (SF Roof Area)

A thin plastic that is formed into tiles and applied over sloped roofs.

Cost includes the appropriate flashing, gutters, fasteners, and openings typical of the model.

RW METAL SANDWICH PANEL (SF Roof Area)

Prefabricated insulated sandwich panel with metal exterior and interior. Cost includes roof openings and an allowance for protrusions appropriate to the given model and overall building rank.

Cost includes the appropriate flashing, gutters, fasteners, and openings typical of the model.

RWA STAINED GLASS WINDOW (SF Area)

Rose or wheel art glass windows with intricate designs in which the smallest dimension of the dominant pieces is 4 inches or greater.

RWB STAINED GLASS WINDOW (SF Area)

Rose or wheel art glass windows with intricate designs in which the smallest dimension of the dominant pieces is between 2 and 4 inches.

RWC STAINED GLASS WINDOW (SF Area)

Rose or wheel art glass windows with intricate designs in which the smallest dimension of the dominant pieces is less than 2 inches.

Prefabricated insulated metal sandwich panel. Used on the roof of cold storage facilities.

Cost includes the appropriate flashing, gutters, fasteners, and openings typical of the occupancy.

For porcelain enamel finish, add component RBC.

RWY AIRPORT RUNWAY (SF of Runway)

A major airport runway.

Cost for major airport runway, 42" thick (16" to 22" concrete topping). Imported earthwork can more than triple the costs.

The cost does not include any offsite work and environmental issues.

RWYR AIRPORT RUNWAY REPLACEMENT (SF of Runway)

A major airport runway concrete replacement.

Cost for a major airport runway, concrete replacement, including removal.

The cost does not include sub-base work, disposal or runway closure cost.

RX METAL SANDWICH PANEL, COLD STORAGE (SF Roof Area)

Prefabricated insulated metal sandwich panel. Used on the roof of cold storage facilities.

Cost includes the appropriate flashing, gutters, fasteners, and openings typical of the model.

For porcelain enamel finish, add component RBC.

RY METAL, PREFORMED SHEETS (SF Roof Area)

Preformed corrugated or crimped sheet roof cover. Cost includes the appropriate flashing, gutters, fasteners, and openings typical of the occupancy.

For porcelain enamel finish, add component RBC.

RZ METAL, FORMED SEAMS (SF Roof Area)

Metal sheet panels with formed seams. Cost includes the appropriate flashing, gutters, fasteners, and openings typical of the occupancy.

For porcelain enamel finish, add component RBC.

Rank 1 for flat or standing seam.

Rank 4 for batten seam.

SBC SHUFFLEBOARD COURT (EA Court)

An open raised area (52' x 6'), paved with concrete and marked with the appropriate lines for playing of shuffleboard.

SCL TRUCK SCALE (EA @ Ton)

Capacity Range: 20–70 Tons

A concrete and steel drive-on truck scale.

The cost includes reinforced concrete pit and platform with steel scale mechanism.

SCO SPECIAL CONSTRUCTION (Dollar Amount)

Restrictions: \$250,000–\$9,999,999

Model 099–3

Commercial and Industrial only

Use for site improvements or building additions that are unique and do not have the features as described in the cost components. Actual construction costs may be listed using a single total dollar amount. It will be the responsibility of the county assessor to trend the cost on an annual basis. Indicate review code 9 on listing form.

The costs will not be automatically updated by the construction cost system.

SDA STAINED GLASS WINDOW (SF Area)

Art glass windows with simple designs, geometric patterns, and silhouettes. The smallest dimension of the dominant pieces is 4 inches or greater.

SDB STAINED GLASS WINDOW (SF Area)

Art glass windows with simple designs, geometric patterns, and silhouettes. The smallest dimension of the dominant pieces is between 2 and 4 inches.

SDE STAINED GLASS WINDOW (SF Area)

Art glass windows with simple designs, geometric patterns, and silhouettes. The smallest dimension of the dominant pieces is less than 2 inches.

SFA STAINED GLASS WINDOW (SF Area)

Art glass windows having simple figures and scenes and very little detail. The smallest dimension of the dominant pieces is 4 inches or greater.

SFB STAINED GLASS WINDOW (SF Area)

Art glass windows having simple figures and scenes and very little detail. The smallest dimension of the dominant pieces is between 2 and 4 inches.

SFC STAINED GLASS WINDOW (SF Area)

Art glass window having simple figures and scenes and very little detail. The smallest dimension of the dominant pieces is less than 2 inches.

SGA CLEAR GLASS (SF Area)

Residential-type clear glass with straight line seam patterns. The smallest dimension of the dominant pieces is 14 inches or greater.

SGB CLEAR GLASS (SF Area)

Residential-type clear glass with straight line seam patterns. The smallest dimension of the dominant pieces is between 10 and 14 inches.

SGC CLEAR GLASS (SF Area)

Residential-type clear glass with straight line seam patterns. The smallest dimension of the dominant pieces is between 6 and 10 inches.

SGD CLEAR GLASS (SF Area)

Residential-type clear glass with straight line seam patterns. The smallest dimension of the dominant pieces is less than 6 inches.

SGE SINGLE COLOR (SF Area)

Residential-type single color glass with straight line seam patterns. The smallest dimension of the dominant pieces is 14 inches or greater.

SGF	SINGLE COLOR (SF Area) Residential-type single color glass with straight line seam patterns. The smallest dimension of the dominant pieces is between 10 and 14 inches.
SGG	SINGLE COLOR (SF Area) Residential-type single color glass with straight line seam patterns. The smallest dimension of the dominant pieces is between 6 and 10 inches.
SGH	SINGLE COLOR (SF Area) Residential-type single color glass with straight line seam patterns. The smallest dimension of the dominant pieces is less than 6 inches.
SGJ	MULTICOLOR (SF Area) Residential-type multicolor glass with straight line seam patterns. The smallest dimension of the dominant pieces is 14 inches or greater.
SGK	MULTICOLOR (SF Area) Residential-type multicolor glass with straight line seam patterns. The smallest dimension of the dominant pieces is between 10 and 14 inches.
SGL	MULTICOLOR (SF Area) Residential-type multicolor glass with straight line seam patterns. The smallest dimension of the dominant pieces is between 6 and 10 inches.
SGM	MULTICOLOR (SF Area) Residential-type multicolor glass with straight line seam patterns. The smallest dimension of the dominant pieces is less than 6 inches.
SGN	RONDELS AND ACCIDENTAL DESIGNS (SF Area) Residential-type windows designed as rondels having accidental designs.
SGP	ACRYLIC RESIN PANELS (SF Area) Simulated art glass. Use a high rank for leading on two sides.

SIO SERVICE ISLAND OFFICE (SF of Office)

Size Range: 25–300 SF

Complete metal prefabricated cashier booth-type building. The cost includes lighting and installation.

Registers, intercom systems, heating and cooling, and remote control equipment are not included in the cost.

Rank 1 for open style with minimum lighting and no plumbing.

Rank 4 for fully enclosed security structure with 2 to 3 plumbing fixtures.

SLR SOLAR ROOM (SF)

Size Range: 35–900 SF

A 3-wall glass enclosed room typically attached to a commercial structure providing a suitable retail or dining area. This component may be found attached to high-end residential improvements. The cost includes foundation, glazing, anodized aluminum frame, openings, and installation.

Floor, electrical, heating, shading devices, and plumbing are not included in the cost.

Rank 1 for single-glazed tempered glass.

Rank 2 for single-glazed tinted or heat reflective glass.

Rank 3 for double-glazed tempered glass.

Rank 4 for double-glazed tinted or heat reflective glass.

SPA SPA, ATTACHED TO POOL (EA)

A division within a swimming pool, used as a spa. Costs include built-in seating and water jets.

SPA E AQUATIC EXERCISE POOL

An 8' X 18' built-in residential, fiberglass aquatic exercise pool. The cost includes 5-hp paddlewheel propulsion system, pump, filter and electric heater. Rank according to the chart below.

Rank 2 42" depth, flat floor

Rank 3 50" depth, side wall water return channels

Rank 4 60" depth, deep water running platform

SPB SWIM POOL, GUNITE (LF of Perimeter)

Size Range: 50–130 LF

Residential swimming pool constructed of sprayed gunite. Cost includes excavation, installation, concrete coping, light, steps, and ladder.

Diving board (SPN), heater (SPD), filter (SPM), chlorinator (SPE), and deck paving are not included in the cost.

The complexity of the site should be considered when selecting a rank.

SPC SWIM POOL, POURED CONCRETE (SF Pool Area)

Size Range: 900–10,000 SF

Commercial poured concrete swimming pool. The cost includes excavation, concrete, coping, filtering, chlorinating, heating equipment, diving boards, and ladders.

Rank is influenced by:

—Shape: Rank 1 for square.

Rank 4 for very irregular.

—Size: Rank 1 for large.

Rank 4 for small.

SPD HEATER (EA)

Heater for residential swim pool. The cost includes installation and associated connections.

The heating capacity of the unit and complexity of installation should be considered when selecting a rank.

SPE CHLORINATOR (EA)

Device attached to the filtration system of a swimming pool that adds chlorine to the water at a controlled rate.

SPF SWIM POOL, FIBERGLASS (LF of Perimeter)

Size Range: 50–130 LF

Residential swimming pool constructed of fiberglass. Cost includes excavation, installation, coping, light, steps, and ladder.

Diving board (SPN), deck, heater (SPD), filter (SPM), and chlorinator (SPE) are not included.

The quality of workmanship and complexity of the site should be considered when selecting a rank.

SPG SWIM POOL, CONCRETE (LF of Perimeter)

Size Range: 50–130 LF

Residential swimming pool constructed of poured concrete. Cost includes excavation, installation, coping, light, steps, and ladder.

Diving board (SPN), deck, heater (SPD), filter (SPM), and chlorinator (SPE) are not included.

The quality of workmanship and complexity of the site should be considered when selecting a rank.

SPH SWIM POOL, PLASTIC LINED (LF of Perimeter)

Size Range: 50–130 LF

Plastic-lined, sand-supported, residential swimming pool. Cost includes excavation, installation, coping, light, steps, and ladder.

Diving board (SPN), deck, heater (SPD), filter (SPM), and chlorinator (SPE) are not included.

The quality of workmanship and complexity of the site should be considered when selecting a rank.

SPI SOLAR SWIMMING POOL HEATING (SF Collector)

Solar heater for swimming pool. The cost includes installation, associated connections, collectors, valves, racks, and 200 feet of PVC solar loop piping.

The heating capacity of the unit and complexity of installation should be considered when selecting a rank.

Low ranks are plastic.

Average ranks are metal, unglazed.

High ranks are metal, glazed.

Note: In order to comply with the provisions regarding Solar Energy Devices in HB 2429, **SPI** will not generate a cost on improvement listings in the Construction Cost System starting in Tax Year 2008.

SPK SWIM POOL, GUNITE (SF Pool Area)

Size Range: 900–10,000 SF

Commercial sprayed gunite swim pool. Cost includes excavation, concrete, coping, filtering, chlorinating, heating equipment, diving boards, and ladders.

Rank is influenced by:

- Shape: Rank 1 for square.
Rank 4 for very irregular.
- Size: Rank 1 for large.
Rank 4 for small.

SPM FILTER (EA)

Water filter for residential swimming pool.

SPN DIVING BOARD (EA)

Board, springs, and other associated hardware related to a swimming pool diving board.

SPP HYDROSWEEP (EA)

An automatic swimming pool cleaning device that uses suction.

SPR SPA, DETACHED (EA)

A stand-alone whirlpool bath with built-in seating.

SPRA SAUNA BATH (SF Bath)

Sauna bath for residential and commercial applications. Cost includes wall, floor, ceiling finish, door, heater, and controls.

- Rank 1 for 75–100 square feet.
- Rank 2 for 50–74 square feet.
- Rank 3 for 25–49 square feet.
- Rank 4 for 15–24 square feet.

SPW SPIRAL STAIRS, ALUMINUM (EA flight)

Constructed of aluminum, in a spiral or circular design.

The stairway design should be considered when selecting a rank.

SPX LADDER, ALUMINUM (LF)**SPY LADDER, SAFETY CAGE (LF)**

The above features are found in warehouses, industrials, lofts, and garages.

SRA COPPER OR TERNE CUPOLA, UP TO 10 FEET (LF of Height)**SRB COPPER OR TERNE CUPOLA, 10 TO 20 FEET (LF of Height)****SRC COPPER OR TERNE CUPOLA, OVER 20 FEET (LF of Height)**

A small square or rectangular structure composed of copper or terne metal materials. Used as roof ventilation or ornamentation. It is located along the roof ridge. It may be used in conjunction with cupola clocks, or as the base for spire components as part of a steeple.

SRD FIBERGLASS CUPOLA, UP TO 10 FEET (LF of Height)**SRE FIBERGLASS CUPOLA, 10 TO 20 FEET (LF of Height)****SRF FIBERGLASS CUPOLA, OVER 20 FEET (LF of Height)**

A small square or rectangular structure composed of fiberglass. Used as roof ventilation or ornamentation. It is located along the roof ridge. It may be used in conjunction with cupola clocks, or as the base for spire components as part of a steeple.

SRG METAL CUPOLA, UP TO 10 FEET (LF of Height)**SRH METAL CUPOLA, 10 TO 20 FEET (LF of Height)****SRJ METAL CUPOLA, OVER 20 FEET (LF of Height)**

A small square or rectangular structure composed of aluminum or steel. Used as roof ventilation or ornamentation. It is located along the roof ridge. It may be used in conjunction with cupola clocks, or as the base for spire components as part of a steeple.

-
- SRK WOOD CUPOLA, UP TO 10 FEET (LF of Height)**
 - SRL WOOD CUPOLA, 10 TO 20 FEET (LF of Height)**
 - SRM WOOD CUPOLA, OVER 20 FEET (LF of Height)**

A small square or rectangular structure composed of wood. Used as roof ventilation or ornamentation. It is located along the roof ridge. It may be used in conjunction with cupola clocks, or as the base for spire components as part of a steeple.

- SRN COPPER OR TERNE SPIRE, UP TO 10 FEET (LF of Height)**
- SRP COPPER OR TERNE SPIRE, 10 TO 20 FEET (LF of Height)**
- SRQ COPPER OR TERNE SPIRE, OVER 20 FEET (LF of Height)**

The tall and acutely pointed copper or terne metal extension above the cupola base of a steeple. This component is most often found on churches.

- SRR FIBERGLASS SPIRE, Up TO 10 FEET (LF of Height)**
- SRS FIBERGLASS SPIRE, 10 TO 20 FEET (LF of Height)**
- SRT FIBERGLASS SPIRE, OVER 20 FEET (LF of Height)**

The tall and acutely pointed fiberglass extension above the cupola base of a steeple. This component is most often found on churches.

- SRU METAL SPIRE, UP TO 10 FEET (LF of Height)**
- SRV METAL SPIRE, 10 TO 20 FEET (LF of Height)**
- SRW METAL SPIRE, OVER 20 FEET (LF of Height)**

The tall and acutely pointed aluminum or steel extension above the cupola base of a steeple. This component is most often found on churches.

- SRX WOOD SPIRE, UP TO 10 FEET (LF of Height)**
- SRY WOOD SPIRE, 10 TO 20 FEET (LF of Height)**
- SRZ WOOD SPIRE, OVER 20 FEET (LF of Height)**

The tall and acutely pointed wood extension above the cupola base of a steeple. This component is most often found on churches.

- SSA STEEPLE CROSS (LF of Height)**

Restrictions: Model 903-x only

A decorative cross mounted at the top of a church tower or steeple.

The rank is influenced by the intricacy of the cross design.

- SSB STEEPLE SPIKE (LF of Height)**

Restrictions: Model 903-x only

A decorative pointed rod mounted at the top of a church tower or steeple.

The rank is influenced by the intricacy of the spike design.

SSC STEEPLE BALL (EA)

Restrictions: Model 903-x only

A decorative ball mounted at the top of a church tower or steeple.

Rank is influenced by the intricacy of the ball design.

SSD CUPOLA CLOCK (EA Face)

Exterior clock mounted in a cupola. The cost includes installation.

Rank is influenced by the delicacy of the clock movement, size of the face, and the complexity of the mounting.

SSG SMALL FIBERGLASS DOME (Diameter of Base in Feet)

Restrictions: Up to 8 feet in diameter

A hemispherical-shaped fiberglass roof.

Cost includes the dome structure only.

The complexity of installation should be considered when selecting a rank.

SSH SMALL METAL DOME (Diameter of Base in Feet)

Restrictions: Up to 8 feet in diameter only

A hemispherical-shaped aluminum or steel roof. Cost includes the dome structure only.

The complexity of installation should be considered when selecting a rank.

SSI SMALL STUCCO DOME (Diameter of Base in Feet)

Restrictions: Up to 8 feet in diameter only

A hemispherical-shaped stucco roof. Cost includes the dome structure only.

The complexity of installation should be considered when selecting a rank.

SSJ SMALL WOOD DOME (Diameter of Base in Feet)

Restrictions: Up to 8 feet in diameter only

A hemispherical-shaped wood roof. Cost includes the dome structure only.

The complexity of installation should be considered when selecting a rank.

SSK LARGE FIBERGLASS DOME (Diameter of Base in Feet)

Restrictions: Above 8 feet in diameter only

A hemispherical-shaped fiberglass roof. Cost includes the dome structure only.

The complexity of installation should be considered when selecting a rank.

SSL LARGE METAL DOME (Diameter of Base in Feet)

Restrictions: Above 8 feet in diameter only

A hemispherical-shaped aluminum or steel roof. Cost includes the dome structure only.

The complexity of installation should be considered when selecting a rank.

SSM LARGE WOOD DOME (Diameter of Base in Feet)

Restrictions: Above 8 feet in diameter only

A hemispherical-shaped wood roof. Cost includes the dome structure only.

The complexity of installation should be considered when selecting a rank.

SSQ TOWER, COMMON BRICK MASONRY (SF Wall Area)

A church tower constructed of common brick. It starts at ground level and extends above the roof line. The tower may be an integral part of the building, attached to the building, or separate from the building.

When the base of a tower is used as a room or office, it should be priced with the rest of the building. In these instances, this component is used for the surface area above the main building roof line only.

Use component STM for interior facing and component STN for tower stairs.

SSR TOWER, FACE BRICK (ADD; SF Wall Area)

This component is used for the added cost of a face brick finish on the church tower made of common brick masonry (component SSQ).

The type of bond used should be considered when selecting a rank.

SST TOWER, CONCRETE (SF Wall Area)

A church tower constructed of concrete. It starts at ground level and extends above the roof line. The tower may be an integral part of the building, attached to the building, or separate from the building.

When the base of a tower is used as a room or office, it should be priced with the rest of the building. In these instances, this component is used for the surface area above the main building roof line only.

Use component STM interior facing and component STN for tower stairs.

SSU TOWER, CONCRETE BLOCK (SF Wall Area)

A church tower constructed of concrete block. It starts at ground level and extends above the roof line. The tower may be an integral part of the building, attached to the building, or separate from the building.

When the base of a tower is used as a room or office, it should be priced with the rest of the building. In these instances, this component is used for the surface area above the main building roof line only.

Use component STM for interior facing and component STN for tower stairs.

SSV TOWER, METAL (SF Wall Area)

A church tower constructed of metal panel siding and a stud frame. It starts at ground level and extends above the roof line. The tower may be an integral part of the building, attached to the building, or separate from the building.

When the base of a tower is used as a room or office, it should be priced with the rest of the building. In these instances, this component is used for the surface area above the main building roof line only.

Use component STM for interior facing and component STN for tower stairs.

SSW TOWER, STONE VENEER (ADD; SF Wall Area)

Use this component for the added cost of stone veneer on church towers made of concrete (component SST) or concrete block (component SSU).

The complexity of the stone pattern should be considered when selecting a rank.

SSX TOWER, STONE MASONRY (SF Wall Area)

A church tower constructed of solid stone masonry. It starts at ground level and extends above the roof line. The tower may be an integral part of the building, attached to the building, or separate from the building.

When the base of a tower is used as a room or office, it should be priced with the rest of the building. In these instances, this component is used for the surface area above the main building roof line only.

Use component STM for interior facing and component STN for tower stairs.

SSY TOWER, WOOD SIDING (SF Wall Area)

A church tower constructed of a wood siding and a stud frame. It starts at ground level and extends above the roof line. The tower may be an integral part of the building, attached to the building, or separate from the building.

When the base of a tower is used as a room or office, it should be priced with the rest of the building. In these instances, this component is used for the surface area above the main building roof line only.

Use component STM for interior facing and component STN for tower stairs.

SSZ TOWER, STUCCO (SF Wall Area)

A church tower constructed of stucco and a stud frame. It starts at ground level and extends above the roof line. The tower may be an integral part of the building, attached to the building, or separate from the building.

When the base of a tower is used as a room or office, it should be priced with the rest of the building. In these instances, this component is used for the surface area above the main building roof line only.

Use component STM for interior facing and component STN for tower stairs.

STE TOWER, ADOBE (SF Wall Area)

A church tower constructed of adobe brick. It starts at ground level and extends above the roof line. The tower may be an integral part of the building, attached to the building, or separate from the building.

When the base of the tower is used as a room or office, it should be priced with the rest of the building. In these instances, this component is used for the surface area above the main building roof line only.

Use component STM for interior facing and component STN for tower stairs.

STF TOWER, STUCCO (ADD; SF Wall Area)

Use this component for the added cost of a stucco finish on a church tower made of concrete (component SST) or concrete block (component SSU).

The number and thickness of the stucco coats and the use of color should be considered when selecting a rank.

STG TOWER, TILE (ADD; SF Wall Area)

Use this component for the added cost of a tile finish on a church tower made of concrete (component SST) or concrete block (component SSU).

STH TOWER, BRICK VENEER (ADD; SF Wall Area)

Use this component for the added cost of a brick veneer finish on a church tower made of concrete (component SST) or concrete block (component SSU).

STJ TOWER, SHINGLE (SF Wall Area)

A church tower constructed of wood shingle and a stud frame. It starts at ground level and extends above the roof line. The tower may be an integral part of the building, attached to the building, or separate from the building.

When the base of a tower is used as a room or office, it should be priced with the rest of the building. In these instances, this component is used for the surface area above the main building roof line only.

Use component STM for interior facing and component STN for tower stairs.

STK TOWER, BRICK VENEER (ADD; SF Wall Area)

A church tower constructed of brick veneer and a stud frame. It starts at ground level and extends above the roof line. The tower may be an integral part of the building, attached to the building, or separate from the building.

When the base of the tower is used as a room or office, it should be priced with the rest of the building. In these instances, this component is used for the surface area above the main building roof line only.

Use component STM for interior facing and component STN for tower stairs.

STL TOWER, STONE VENEER (ADD; SF Wall Area)

A church tower constructed of stone veneer and a stud frame. It starts at ground level and extends above the roof line. The tower may be an integral part of the building, attached to the building, or separate from the building.

When the base of a tower is used as a room or office, it should be priced with the rest of the building. In these instances, this component is used for the surface area above the main building roof line only.

Use component STM for interior facing and component STN for tower stairs.

STM TOWER, INTERIOR FACING (ADD; SF Wall Area)

This component is used for the added cost of painted drywall, plaster, or paneling on the interior wall of a church tower.

STN TOWER STAIRS (ADD; LF of Height)

This component is used for the added cost of stairs in a church tower.

STX STORAGE-UTILITY BUILDING (SF)

Restrictions: 600 square feet of floor area maximum

A storage-utility building is a complete structure used for storage purposes or a workshop. The cost includes foundation, floor, exterior wall, roof structure/cover, and electrical.

Rank is influenced by:

- Material and workmanship
- Amount of electrical service
- Exterior wall construction

STXG STORAGE BUILDING, GALVALUME (SF)

A prefabricated metal storage building having a traditional or modified Quonset design and walls made of galvalume metal. Galvalume metal is made from a mixture of aluminum and zinc and is characterized by large raised seams. The cost includes concrete footings, shell with minimum fenestration, and installation.

Floor, heating, electrical, plumbing, and end walls are not included in the cost and must be added if present. This component may be used with any model.

Use the following table to select a rank:

RANK TABLE									
STXG STORAGE BUILDING, GALVALUME									
LENGTH (feet)	WIDTH (feet)								
	16	20	25	30	33	36	40	45	50
20	4.0	—	—	—	—	—	—	—	—
24	3.8	3.6	—	—	—	—	—	—	—
30	3.6	3.3	2.9	—	—	—	—	—	—
36	3.4	2.9	2.8	2.6	2.4	—	—	—	—
40	3.2	2.8	2.6	2.5	2.3	2.2	—	—	—
44	2.8	2.7	2.5	2.3	2.1	2.1	2.1	—	—
50	2.7	2.6	2.3	2.1	2.0	1.9	1.8	1.5	—
60	2.5	2.5	2.1	1.8	1.8	1.8	1.5	1.5	1.5
80	2.4	2.1	1.8	1.6	1.6	1.6	1.3	1.3	1.2
100	2.1	1.8	1.5	1.5	1.5	1.5	1.0	1.0	1.0

STXM STORAGE SHED, MINIMUM GRADE (SF)

Restrictions: 600 square feet of floor area maximum

A storage–utility building is a complete structure used for storage purposes or a workshop, and is usually constructed of used material. The cost includes foundation, exterior wall, roof structure and cover, and floor.

Rank is influenced by the percentage of all components present in the structure.

TA ELEVATOR (SF)

Costs are given for the elevators typical in buildings that would have elevators (office, hospital, high rise apartments, etc.), and are based on the number of square feet of floor area served. Finish is based on occupancy and cost rank selected.

TCA TENNIS COURT, ASPHALT (EA)

An exterior tennis court (60' x 120') with an asphalt surface. The cost includes leveling, posts, net, and striping.

Use component TCL for lighting and component TCF for a fence around the court.

TCC TENNIS COURT, CONCRETE (EA)

An exterior tennis court (60' x 120') with a concrete surface. The cost includes leveling, posts, net, and striping.

Use component TCL for lighting and component TCF for a fence around the court.

TCF FENCE, TENNIS COURT (EA Court)

Chain link fencing surrounding a tennis court. The cost includes gates.

The height of the fence and the presence of screening material should be considered when selecting a rank.

Use component WCL to calculate the cost of the fence on a square foot method.

TCL LIGHTING, TENNIS COURT (EA Court)

Outdoor lighting fixtures mounted on poles. These lights provide lighting for nighttime play at a tennis court. Wiring is included in the cost.

TF1 FREIGHT ELEVATOR, HYDRAULIC, MANUAL DOORS (Cars, Stops – Rank Table)

Hydraulic elevator suitable for movement of freight from one level to another. The doors are manually operated. Normal operation is from 2 to 7 stops.

Use the following table to select a rank:

SPEED (fpm)	CAPACITY (pounds)							
	2,000	4,000	5,000	6,000	8,000	10,000	15,000	20,000
50	1.0	1.4	1.5	1.6	1.8	2.5	3.1	3.6
100	1.5	1.8	1.9	2.0	2.1	2.8	3.4	3.8
125	1.7	2.0	2.1	2.2	2.3	2.9	3.5	3.9
150	2.0	2.2	2.2	2.3	2.4	3.0	3.6	4.0

TF2 FREIGHT ELEVATOR, HYDRAULIC, POWER DOORS (Cars, Stops – Rank Table)

Hydraulic elevator suitable for movement of freight from one level to another. The doors are power operated. Normal operation is from 2 to 7 stops.

Use the following table to select a rank:

SPEED (fpm)	CAPACITY (pounds)							
	2,000	4,000	5,000	6,000	8,000	10,000	15,000	20,000
50	1.0	1.4	1.5	1.6	1.8	2.5	3.1	3.6
100	1.5	1.8	1.9	2.0	2.1	2.8	3.4	3.8
125	1.7	2.0	2.1	2.2	2.3	2.9	3.5	3.9
150	2.0	2.2	2.2	2.3	2.4	3.0	3.6	4.0

TF3 FREIGHT ELEVATOR, ELECTRIC, MANUAL DOORS (Cars, Stops – Rank Table)

Electric elevator suitable for movement of freight from one level to another. The doors are manually operated. Elevator speed is usually controlled by variable voltage.

Use the following table to select a rank:

SPEED (fpm)	CAPACITY (pounds)							
	2,000	4,000	5,000	6,000	8,000	10,000	15,000	20,000
100	1.0	1.3	1.4	1.5	1.8	2.0	—	—
200	1.5	1.8	1.9	2.1	2.4	3.0	3.8	—
300	1.9	2.3	2.5	2.6	3.0	3.6	—	—
400	2.4	2.7	3.0	3.2	3.6	4.0	—	—

**TF4 FREIGHT ELEVATOR, ELECTRIC, POWER DOORS
(Cars, Stops – Rank Table)**

Electric elevator suitable for movement of freight from one level to another. The doors are power operated. Elevator speed is usually controlled by variable voltage.

Use the following table to select a rank:

SPEED (fpm)	CAPACITY (pounds)							
	2,000	4,000	5,000	6,000	8,000	10,000	15,000	20,000
100	1.0	1.3	1.4	1.5	1.8	2.0	—	—
200	1.5	1.8	1.9	2.1	2.4	3.0	3.8	—
300	1.9	2.3	2.5	2.6	3.0	3.6	—	—
400	2.4	2.7	3.0	3.2	3.6	4.0	—	—

TH PERSONNEL LIFT (Cars, Stops)

Revolving vertical belt with a 1-man platform. The cost includes belt, platforms, controls, and supports.

The length of the belt and the capacity of the lift must be considered when selecting a rank.

TJ DUMBWAITER, ELECTRIC (Cars, Stops)

A small electric elevator with a stainless steel cab. Dumbwaiters are generally used for moving small supplies or food between floors.

TK SIDEWALK ELEVATOR (Cars, Stops)

Electricity-operated platform lift suitable for raising materials from a basement to sidewalk. These elevators generally have large platforms and doors. The cost includes hoist, platform, tracks, sidewalk door, and controls.

- Rank is influenced by:
- Rated capacity
 - Platform size
 - Quality of platform and doors

TL ESCALATOR (EA Stairway)

Enter number of stairways. Costs vary depending on the width of the stairway (the wider the stairway, the higher capacity of people moving provided) and the length of the stairway.

Use the following table to select a rank:

RISE (in feet)	WIDTH	
	32 inches	48 inches
10	1.0	1.8
14	1.5	2.4
18	2.0	3.0
22	2.5	3.5
25	2.9	4.0

TM DUMBWAITER, HAND-OPERATED (Cars, Stops)

A small hand-operated elevator with a stainless steel cab. Dumbwaiters are generally used for moving small supplies or food between floors.

TN ELEVATOR, 2-STORY, SINGLE FAMILY (EA)

Restrictions: Residence and Condominium models only

These are small residential elevators that have a limited capacity (generally 1,200 pounds). The controls may be either cable or hydraulic (hydraulic is the most common). There are shaft openings and stops on 2 floor levels.

TO ELEVATOR, 3-STORY (EA)

Restrictions: Residence and Condominium models only

These are small residential elevators that have a limited capacity (generally 1,200 pounds). The controls may be either cable or hydraulic (hydraulic is the most common). There are shaft openings and stops on 3 floor levels.

TP INCLINATOR (EA; Per 14- to 17-Foot Run)

Designed for transportation to upper floor levels. They typically cover diagonal runs of between 14 and 17 feet, and can be adapted for handicapped application.

TQ WHEELCHAIR LIFT (EA)

A vertical lift used for wheelchairs. This elevator has a 400-pound capacity.

TR BYPASSED FLOORS (For All Cars, Total Number of Floors With No Stops)

This component adjusts for the difference in cost when floors in an express elevator are bypassed. Cost includes the track and supports.

The story height must be considered when selecting a rank.

TRE TRASH ENCLOSURE (EA)

The trash enclosure consists of three block walls with a concrete floor to provide space for trash containers. Wall height is 6 feet.

Use the following components for gates:

WCG Gate, Chain Link
WFG Gate, Wood
WMG Gate, Metal

Rank 1 for 80 square feet.
Rank 3 for 120 square feet.

TS ELEVATOR, MULTISTORY, PASSENGER OPERATED, HYDRAULIC (Cars, Stops – Rank Table)

Hydraulic passenger elevator with push-button controls. Normal operation is from 2 to 7 stops. The cost includes the plunger.

Use the following table to select a rank:

SPEED (fpm)	CAPACITY (pounds)					
	1,500	2,000	2,500	3,000	4,000	5,000
50	1.0	1.4	1.8	2.1	2.5	2.9
75	1.4	1.9	2.2	2.4	2.9	3.2
100	1.8	2.2	2.5	2.8	3.1	3.4
125	2.0	2.4	2.7	3.0	3.3	3.6
150	2.3	2.6	2.9	3.1	3.4	3.7
200	2.5	2.9	3.2	3.4	3.7	3.9

TT ELEVATOR, MULTISTORY, PASSENGER OPERATED, ELECTRIC (Cars, Stops – Rank Table)

Electric-gearred passenger elevator with push-button controls. This elevator has a capacity of 1,200 to 5,000 pounds. The speed can be between 50 and 400 feet per minute.

Use the following table to select a rank:

SPEED (fpm)	CAPACITY (pounds)							
	AC	Rheostatic	Variable Voltage					
	1,200	2,000	1,500	2,000	2,500	3,000	4,000	5,000
50	1.0	1.4	—	—	—	—	—	—
100	1.6	2.0	2.0	2.2	2.5	2.7	3.0	3.2
150	2.0	2.3	2.2	2.6	2.7	2.9	3.2	3.4
200	—	—	2.5	2.7	2.9	3.1	3.3	3.6
300	—	—	2.8	3.0	3.2	3.3	3.7	3.8
400	—	—	3.0	3.2	3.4	3.5	3.8	4.0

TU ELEVATOR, MULTISTORY, FULLY AUTOMATIC (Cars, Stops – Rank Table)

Electric-gearred passenger elevator with push-button controls. This elevator has a capacity of 2,000 to 5,000 pounds. The speed can be between 300 and 1,400 feet per minute.

Use the following table to select a rank:

SPEED (fpm)	CAPACITY (pounds)					
	2,000	2,500	3,000	3,500	4,000	5,000
300	1.0	1.1	1.2	1.3	1.4	1.7
400	1.2	1.3	1.4	1.5	1.7	1.9
500	1.4	1.5	1.6	1.8	1.9	2.1
600	1.6	1.7	1.9	2.0	2.1	2.3
700	1.8	2.0	2.1	2.2	2.3	2.5
800	2.0	2.2	2.3	2.4	2.5	2.7
1000	2.5	2.6	2.7	2.8	2.9	3.2
1200	2.9	3.0	3.1	3.2	3.3	3.6
1400	3.3	3.4	3.5	3.7	3.8	4.0

TV MOVING WALK (LF – Rank Table)

A self-contained moving belt designed to transport people from one point to another at the same or different levels. The width of the walk can be between 36 and 54 inches. The cost includes pulleys, handrails, and balustrade.

Use the following table to select rank:

LENGTH (linear)	WIDTH		
	36 inches	48 inches	54 inches
100	3.4	3.8	4.0
300	2.5	2.9	3.2
500	2.1	2.5	2.8
750	1.7	2.2	2.5
1,000	1.5	2.0	2.3
1,400	1.3	1.7	2.0
1,800	1.0	1.5	1.9

TW RECTANGULAR VAULT DOORS (EA – Rank Table)

Vault doors are generally found in banks or savings and loans. The cost includes a time lock, day gate, sill, and other hardware.

Use the following table to select a rank:

THICK (inches)	RANK	THICK (inches)	RANK
2	1.0	10	3.0
3	1.3	12	3.3
4	1.7	14	3.7
6	2.0	16	4.0
8	2.5	—	—

TWA DRIVE-UP WINDOW (EA)

A bank or savings and loan drive-up or walk-up window. The cost includes a vision window, complete installation, and necessary accessories.

TWB DRIVE-UP PNEUMATIC TUBE SYSTEM (EA Lane)

Pneumatic transfer system consisting of terminals and tube used at a drive-up window.

Canopy and window are not included in the cost.
Rank is influenced by length of run and capacity of the vacuum pump.

TWC DRIVE-IN TELLER'S BOOTH (EA)

Complete drive-in teller's booth with rest room and canopy. These booths are typically 400 to 600 square feet. The cost includes foundation, floor, walls, roof, lighting, plumbing, heating and cooling.
Banking equipment is not included in the cost.

Rank is influenced by the size and shape of the booth.

TWD NIGHT DEPOSIT CHUTES-BOXES (EA)

Night deposit chutes or boxes are generally found in banks or savings and loans. The cost includes complete installation and necessary accessories.

UAD	MONEY BANK VAULT (SF Vault Area)
	Typically constructed of poured concrete or some type of masonry wall system. The walls are generally 8 feet high. Built-in alarm systems, ventilators, and interior finish are included in the cost.
	The cost does not include floor or vault doors.
UAE	BATHROOM HEATER (EA)
	Typically found in the ceiling or wall of the bath area. The cost includes the heater, installation, and the associated electrical.
UAF	DISHWASHER (EA)
	Residential porcelain enameled steel tubs used typically in undercounter installations. They may have controls with energy-saving features, i.e., automatic shutoff for forced-air drying. Cost includes installation and any associated plumbing and electrical.
UAG	RECORD STORAGE BANK VAULT (SF Vault Area)
	Applies to the area of the bank used for record storage. Like money storage vaults, the record area is enclosed with walls 8 feet high. The cost includes alarm systems, a 2-hour drywall interior finish, and ventilators, but not vault door or flooring.
UAH	STAGE AND FIXTURES, LIVE PERFORMANCE (SF Stage Area)
	Raised wooden platform used for the live performances. Cost includes troughs and trap doors.
	Rank is influenced by: —Height of platform —Quality of the stage cover (surface area) —Density of built-in fixtures
UAJ	STAGE AND FIXTURES, MOTION PICTURE ONLY (SF Stage Area)
	A wooden platform raised 3 to 4 feet above floor level and projecting away from the screen.
	Rank is influenced by: —Height of the platform —Presence of built-in fixtures

UAK SPEAKER'S PLATFORM (SF Platform Area)

This is a small raised platform made of a wood frame and wood flooring. Typical depths vary from 10 to 20 feet.

UAM WINDOW AIR CONDITIONER (EA)

Refrigerated cooling unit mounted in the window. Generally, they are smaller capacity units of between 1/2-ton and 2-ton.

UAN WINDOW EVAPORATIVE COOLER (EA)

Cooling system in which the evaporative unit is window-mounted. These window units typically can cool between 1,500 and 6,500 cubic feet per minute. Like the roof-mounted evaporative system, they are found in low-humidity climates.

UAO EXHAUST FAN (EA)

Fans found in the bath or kitchen areas to dispel stale or moist air. These fans have some type of metal or plastic grill.

UAOE VENT, APPLIANCE (EA)

Vents found in kitchen areas to dispel stale or moist air; e.g., an island stove and oven.

UAV COOKING HOOD AND DUCT SYSTEM (LF)

Hood suspended over a cooking area to remove fumes. The cost includes ducts and exhaust fans.

Fire-extinguishing equipment and sprinklers are not included in the cost.

Use component UAX for fire-extinguishing system.

Rank 1 for low gauge sheet metal.
Rank 4 for stainless steel.

UAX HOOD AND DUCT FIRE-EXTINGUISHING SYSTEM (EA Head)

Dry chemical dispensing system to extinguish cooking fires. Cost includes nozzle (head), piping, and storage facility.

Use this component with UAV, cooking hood and duct system.

UBI	BLEACHERS, GRANDSTAND (SF of Projection)
	School or fairground-type grandstand. Open steel frame with metal, fiberglass, or wood benches. Cost includes stairs, ramps, and press boxes commensurate with rank. Structures built by governmental agencies tend to be of higher rank.
UBO	BLEACHERS, STADIUM (SF of Projection)
	Concrete or steel closed-deck bleachers. There is no interior construction such as dressing rooms or rest rooms. Cost includes stairs, ramps, and press boxes commensurate with rank. Structures built by governmental agencies tend to be of higher rank.
UBOM	BLEACHERS, MUNICIPAL STADIUM (SF of Projection)
	College or small municipal stadium-type bleachers. Concrete or steel bleachers with dressing rooms, rest rooms, and lighting. Cost includes stairs, ramps, and press boxes commensurate with rank. Structures built by governmental agencies tend to be of higher rank.
UBQ	WINDOW HEAT PUMP (EA)
	A small heat pump that is designed to be installed in a window. Unlike the large heat pump, it only services one room.
UBV	BLEACHERS, TELESCOPING (SF of Projection)
	A stand of tiered planks providing undivided space for seating. This telescoping gymnasium bleacher has a steel frame and wood benches. The telescoping is manually operated.
UBW	BLEACHERS, POWER OPERATION (ADD; SF of Projection)
	This component is used for the added cost of power-operated telescoping.
	It must be used with component UBV (bleachers).
UBX	BLEACHERS, PERMANENT, WOOD (SF of Projection)
	A stand of tiered planks providing undivided space for seating. This permanent gymnasium bleacher has a wood frame and wood benches.

UBY BLEACHERS, PERMANENT, STEEL AND FIBERGLASS (SF of Projection)

A stand of tiered planks providing undivided space for seating. This permanent gymnasium bleacher is made of steel and fiberglass.

UBZ AUDITORIUM SEATING (EA Seat)

This theater-type seating includes installation.

Rank 1 for seats made of plywood.
Rank 4 for upholstered seats.

UC DRINKING FOUNTAIN (EA)

A nonrefrigerated water dispenser. The cost includes fixture, labor, and miscellaneous materials for rough and finish.

Vitreous china is a higher rank than stainless steel.

UD EXHAUST FAN AND HOOD (EA)

Typically found in the kitchen area over a residential range. Usually made of painted steel. They may have blowers that can be operated at variable speeds and a light. Standard sizes come in varying widths from 30 to 42 inches.

UDC FIBERGLASS UNDERGROUND FUEL/OTHER STORAGE TANK (Gallons)

Capacity Range: 500 - 50,000 gallons

Single-wall fiberglass fuel/other storage tank. The cost includes excavation, fittings, and backfill.

Rank is influenced by:
—Soil conditions
—Multiple installations

UDD STEEL UNDERGROUND FUEL/OTHER STORAGE TANK (Gallons)

Capacity Range: 250 - 50,000 gallons

Single-wall steel fuel/other storage tank. Cost includes excavation, fittings, and backfill. Piping is not included.

Rank is influenced by:
—Soil conditions
—Multiple installations

**UDE VERTICAL BULK STORAGE TANK, ABOVE GROUND
(Gallons)**

Capacity Range: 2,000–70,000 gallons

10- to 12-gauge bolted galvanized vertical fuel/other storage tank. The cost includes fittings, sand and gravel foundation, and roof. Piping is not included.

Rank is influenced by:
—Multiple installations
—Complexity of installation

**UDF HORIZONTAL BULK STORAGE TANK, ABOVE
GROUND (Gallons)**

Capacity Range: 1,000–40,000 gallons

Steel horizontal storage tank. The cost includes fittings, saddles or legs, and foundations. Piping is not included.

Rank is influenced by:
—Multiple installations
—Complexity of installation

UDK FAST-FOOD WINDOW (EA)

A drive-up order window. These sliding, metal-framed windows are commonly found in fast-food restaurants.

Rank 1 includes the window only, while the higher ranks include large glass bubble and a stainless steel counter with a drawer or shelf.

UDP PNEUMATIC TUBE SYSTEM

Pneumatic tube systems are generally found in stores and commercial buildings. The cost includes complete installation and necessary accessories. For a bank-type drive-up pneumatic system, use component TWB.

UDST WELDED STEEL FUEL TANKS (Each @ Barrels)

Capacity Range: 2,000 to 500,000 barrels
Enter number of tanks in miscellaneous field and capacity of each tank in units field.

Aboveground welded steel fuel tanks. Cost includes tanks erected on sand or gravel with steel ring curb, cone roofs with supports as needed, outside ladder, roof and shell manholes, threaded and/or flanged openings as needed for operation, roof vents, and paint. Catwalks, stairways, and platforms are not included. For catwalks and stairways, use component BDB (Balcony, Steel) and NAA (Steel Stairway).

UE GARBAGE DISPOSAL (EA)

Self-contained unit attached to the kitchen sink that is used to handle food wastes. The cost includes associated plumbing and electrical.

UEA SMOKE DETECTOR, BATTERY-OPERATED (EA)

A device that sounds a loud alarm when smoke is present. They are generally installed near the ceiling in hallways, bedrooms, and stairwells.

Cost includes installation.

UEB SKYLIGHT (SF Framed Area)

Restrictions: Residential models only

An opening in a ceiling for a window.

Rank 1 for a single dome.

Rank 4 for a double dome.

Note: In order to comply with the provisions regarding Solar Energy Devices in HB 2429, **UEB** will not generate a cost on improvement listings in the Construction Cost System starting in Tax Year 2008.

UETS TUBULAR SKYLIGHT (UN - EA)

Restrictions: Residential models only

A residential tubular skylight. Cost includes all materials and installation. Use the following ranking chart

Diameter	Rank
10"	1
13" to 14"	2
16' to 18'	3
21"	4

Note: In order to comply with the provisions regarding Solar Energy Devices in HB 2429, **UETS** will not generate a cost on improvement listings in the Construction Cost System starting in Tax Year 2008.

UF MIXER-BLENDER (EA)

A built-in residential food processor with controls for starting, stopping, speed, type of operation, and timing.

UG RADIO-INTERCOM (EA)

A built-in wall unit with a combination radio and intercom. This is the base unit for a two-way intercom system. Use component UH for additional intercom stations.

UH RADIO-INTERCOM, SATELLITE (EA)

This added cost is for each station attached to the basic residential intercom station. Use component UG for the basic intercom station.

UJ RANGE AND OVEN (EA)

A residential gas or electric range and conventional oven combined into one unit. The range typically has a multiburner configuration, with single or double ovens that are a drop-in or slide-in type.

Use Rank 3 or 4 if the unit has a double oven (under-over), griddles, or other accompanying features.

For microwave oven combinations, use component UJA.

UJA RANGE AND MICROWAVE COMBINATION (EA)

A residential gas or electric range and oven combined into one unit. The range typically has a multiburner configuration with double ovens, one being a microwave oven. For conventional ovens only, use component UJ.

UK RANGE TOP (EA)

A residential range top built into the cabinets. This unit is generally used in conjunction with a separate built-in oven (UL or ULA) and may be either gas or electric.

For an induction top, use component UKA.

UKA RANGE TOP, INDUCTION (EA)

A residential induction range top built into the cabinets. This unit is generally used in conjunction with a separate built-in oven (UL or ULA).

UL OVENS (EA)

A conventional residential oven(s) built into the cabinetry with glass or porcelain enameled doors and a small window. It may have the self-cleaning or continuous cleaning feature, and can be either gas or electric.

Use rank 4 for double ovens.

For microwave combinations, use component ULA.

ULA OVEN, MICROWAVE COMBINATION (EA)

A double oven unit that is built into cabinetry with glass or porcelain enameled doors and a small window. One oven is microwave, the other is conventional oven that may have a self-cleaning or continuous cleaning feature.

For conventional ovens only, use component UL.

UM REFRIGERATOR (EA)

Freestanding residential refrigerator, usually has baked enamel cabinet finish, with interior porcelain on steel in the better qualities, and a plastic interior in the lower cost units. Common capacities in residential applications are between 12 and 25 cubic feet.

The refrigerator freezer section may be in a side-by-side combination or a top or bottom freezer. Most have adjustable temperature controls.

UN TV OUTLET (EA)

This is the cost for the wiring run and associated connections needed for a master or closed-circuit convenience TV outlet. The cost includes the master antenna.

The TV is not included in the cost.

UO GAS INCINERATOR (EA)

A small fire chamber used for waste disposal. Cost includes the gas piping and outlet.

UP VACUUM CLEANER SYSTEM (EA, Includes 3 Outlets)

A residential base system with 3 wall-mounted vacuum valves. The system utilizes a suction motor and fan and requires electrical, intake, and exhaust lines. Debris is usually stored in a steel receptacle for disposal.

UPA UTILITY PIPING, PRESSURE PIPE, DUCTILE IRON (LF@ DIAMETER)

UPB UTILITY PIPING, PRESSURE PIPE, CAST IRON (LF@ DIAMETER)

UPC UTILITY PIPING, PRESSURE PIPE, CONCRETE (LF@ DIAMETER)

UPD UTILITY PIPING, PRESSURE PIPE, PLASTIC (LF@ DIAMETER)

UPE UTILITY PIPING, PRESSURE PIPE, STEEL (LF@ DIAMETER)

Size Range 4-48 inch diameter

Piping for underground utility lines. Cost includes fittings, trenching and backfill. For non-circular pipe, use the average diameter of the smallest and largest dimension. Enter the diameter in the units field and the linear feet of pipe in the misc. field.

UPF UTILITY PIPING, PRESSURE PIPING, VALVES (EA)

Size Range 4 -48 inch diameter

Pressure valves for underground utility lines. Enter the diameter in the units field and the number of valves in the misc. field.

UPG UTILITY PIPING, DRAIN AND SEWER, CORRUGATED METAL (LF @ DIAMETER)**UPH UTILITY PIPING, DRAIN AND SEWER, PLASTIC (LF@ DIAMETER)****UPJ UTILITY PIPING, DRAIN AND SEWER, PLAIN CONCRETE (LF@ DIAMETER)****UPK UTILITY PIPING, DRAIN AND SEWER, REINFORCED CONCRETE (LF@ DIAMETER)****UPL UTILITY PIPING, DRAIN AND SEWER, VITRIFIED CLAY (LF@DIAMETER)**

Size Range 4-48 inch diameter

Piping for underground utility lines. Cost includes fittings, trenching, and backfill. For non-circular pipe, use the average diameter of the smallest and largest dimension. Enter the diameter in the units field and the linear feet of pipe in the misc. field.

UR TRASH COMPACTOR (EA Central Unit)

This is a large unit found in multitenant properties (for small units, use component US). Waste is deposited in a central unit where it is compacted with the pressure created by a large motor. For individual residential units, use component US.

US TRASH COMPACTOR (EA Single Unit)

A residential freestanding or undercounter unit used for compacting waste. It utilizes one or two cycles using a motor to develop the pressure used for compaction. This unit is generally found in single family residences (for larger trash compactors, use component UR).

UT VACUUM CLEANER SYSTEM, EXTRA OUTLET (ADD; EA)

Add the cost for each residential wall-mounted valve above the base of the three already included. See component UP (vacuum system).

UV MICROWAVE OVEN (EA)

Built-in residential microwave oven. Controls perform a number of cooking operations, e.g., temperature control, delay cooking, automatic shutoff and, in some instances, digital readouts.

UW BANK EQUIPMENT (SF Total Building or Bank Area)

The cost includes safe deposit cabinets, teller cages, counters, vault doors, and other miscellaneous equipment that is not included under the general building contract. These costs represent averages. Costs for bank equipment can vary greatly and this component should therefore be used with caution.

UWA CAR WASH, DECORATIVE LAMPS (EA)

Restrictions: Model 174-x only

Decorative lamps in an automatic car wash, which can be attached to the canopy (UWC) or to ornamental pylons (UWB).

Rank 1 for incandescent.
Rank 4 for fluorescent.

UWB CAR WASH, ORNAMENTAL PYLONS (EA)

Restrictions: Model 174-x only

Ornamental pylons in an automatic car wash.

Rank 1 for simple wood or steel poles.
Rank 4 for decorative metal or masonry towers.

UWC CAR WASH, CANOPY (SF)

Restrictions: Model 174-x only

Canopy over an automatic car wash. The cost includes concrete slab, supports, floor drains, and lighting.

Rank 1 for a light structure with very little finish.

Rank 4 for a structure with fascia and ornamentation.

UX JAIL EQUIPMENT (SF Total Jail Building Area)

Detention equipment and hardware used in jail facilities like metal bars, doors, locking devices and ancillary items associated with cellblocks.

Rank is influenced by:

1. Amount of security required. Rank 1 is minimum security and rank 4 is maximum security.
2. Sophistication of mechanical operating controls.

UZ REFRIGERATED WATER COOLER (EA)

Drinking fountain with electrically refrigerated water. The cost includes service connections.

Rank is influenced by complexity of installation.

VA ALUMINUM SIDING WALLS (SF Garage Wall Area)

Aluminum siding attached to a wood or steel stud frame. The siding may be found in sheets or in conventional lap siding. Cost does not include interior finish. Higher ranks include a pedestrian door and window.

VAC OPEN PORCH, CONCRETE SLAB WITH STEPS (SF Porch Area)

Size Range: 10–2,000 SF

A complete poured concrete residential porch with a number of concrete steps that lead to a concrete entry landing.

Costs include concrete, fill, prorated amount of railing and foundation, which is formed and poured with the residence.

VAD OPEN PORCH, CONCRETE SLAB WITHOUT STEPS (SF of Porch Area)

Size Range: 10–2,000 SF

A complete residential slab porch poured at grade, with perimeter foundation but no steps, which is formed and poured with the residence.

VAE WOOD DECK WITH STEPS (SF Porch Area)

Size Range: 10–2000 SF

A residential wood porch or landing area with steps leading to it. The porch is supported by a wood frame. Costs include foundation piers, wood supports, deck, steps, and a prorated amount of railing. Rank is influenced by type of wood, overall size of deck, and amount of railing.

VAF WOOD DECK WITHOUT STEPS (SF Porch Area)

Size Range: 10–2,000 SF

A residential wood porch deck set at grade. For a wood deck with steps, use component VAE. Costs include foundation piers, wood supports, and decks.

Rank is influenced by type of wood, overall size of deck, and amount of railing.

VAH CEILING (ADD; SF Ceiling Area)

Cost for a ceiling finish attached to the roof of a porch, balcony, or stairwell. The finish is usually of some type of wood, exterior plaster (stucco), or vented panels.

Rank 1 for a light structure with very little finish.
Rank 4 for a structure with fascia and ornamentation.

VAI WOOD BALCONY WITH WOOD RAILS (SF Balcony Area)

Residential wood balconies with wood framing members and a wood deck. The rail is wood frame and may be open or closed.

VAJ WOOD BALCONY WITH IRON RAILS (SF Balcony Area)

Residential wood balcony with wood framing members and wood deck. The rail is ornamental iron. The balcony is created by extending the floor structure beyond the exterior wall.

VAK CEMENT COMPOSITION BALCONY WITH WOOD RAILS (SF Balcony Area)

Residential wood frame balcony with a deck of a cement material, poured and troweled. The rail is wood frame and may be open or closed.

VAL CEMENT COMPOSITION BALCONY WITH IRON RAILS (SF Balcony Area)

Residential wood frame balcony with a cement deck and an ornamental iron rail.

VAM FINISHED SOFFIT, BALCONY (ADD; SF Balcony Area)

Cost for a finished underside of a residential balcony deck.

VAN WOOD STAIRS, WOOD RAILS (EA Flight)

Residential wood exterior stairs with wood framing members, i.e., stringers, posts, treads, and risers. The rail can be open or closed and it is made with a wood frame. Landings are also wood.

-
- VAO WOOD STAIRS, IRON RAILS (EA Flight)**
- Wood exterior stairs with wood framing members, i.e., stringers, posts, treads, and risers. The rail can be open or closed and is made with ornamental iron. Landings are also wood.
- VAP CEMENT COMPOSITION STAIRS, WOOD RAILS (EA Flight)**
- The structural support of the residential stairs is wood. A cement material is poured and troweled over the wood frame members on the treads, risers, and landings. The railing is wood frame.
- VAQ CEMENT COMPOSITION STAIRS, IRON RAILS (EA Flight)**
- The structural support of the residential stairs is wood. A cement material is poured and troweled over the wood frame members on the treads, risers, and landings. The railing is ornamental iron.
- VAR STEEL STAIRS, ORNAMENTAL IRON RAILS (EA Flight)**
- Residential stairs having a steel frame with the landings and treads usually constructed of either a precast concrete slab plank or poured-in-place concrete. The treads may be made with steel pans. Railings can be some type of ornamental iron or steel.
- VAS FINISHED SOFFIT, STAIRWELL (ADD; EA Flight)**
- Cost for finish applied to the underside of the residential exterior stairway. Typically found in stairways with a closed riser.
- VB ASBESTOS WALLS (SF Garage Wall Area)**
- Exterior wall cover composed of asbestos fiber and Portland cement combined under pressure. It can either be a siding or a shingle, and can be applied over a sheathing or a wood frame with building paper.
- Cost does not include interior finish. Higher ranks include a pedestrian door and window.

VC STUCCO WALLS (SF Garage Wall Area)

This exterior wall component is composed of a Portland cement base and sand. It is applied over either wire and paper or a sheathing backed wire and paper.

Cost does not include interior finish. Higher ranks include a pedestrian door and window.

VD WOOD SIDING WALLS (SF Garage Wall Area)

Wood siding finish applied over a building paper only, or a sheathing and building paper. The lower end of the cost scale for wood sidings typically includes the sheet-type sidings, e.g., plywood or hardboard.

Cost does not include interior finish. Higher ranks include a pedestrian door and window.

VDA FIREPLACE, 1-STORY, SINGLE (EA)

Restrictions: Residential models only

Found in 1-story residences and having one chimney that extends above the roof line. There is a hearth and some wall finish associated with the fireplace included in the base cost.

For each additional story (flue) over the base cost of one story, use component VDM. For each additional opening (hearth) over the base cost of one, use component VDP.

Rank is primarily influenced by type of stack, size of box, and hearth facing. Prefabricated metal, precast concrete, and solid masonry fireplace costs ascend in that order.

For raised hearth, use component VDH. For heatilator, use component VDG. For log lighter, use component VDI.

VDF PREFABRICATED FIREPLACE (EA)

Restrictions: Residential models only

These freestanding or hanging 1-story metal fireplaces or wood-burning stoves come complete with hood, damper, chimney pipe, and base. They are constructed or manufactured off-site and transported to the site and installed.

For each additional story (stack) over the base cost of one story, use component VDN. For log lighter, use component VDI. Rank is influenced by the quality and size of the unit.

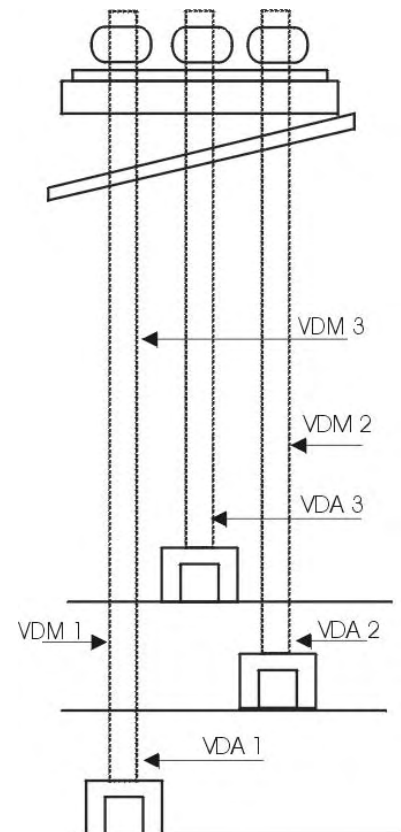

VDG HEATILATOR (ADD; EA)

Restrictions: Residential models only

A metal frame inside the fireplace to conduce heat out into the room. The heatilator is an added cost.

Cost does not include the fireplace or chimney.

VDH RAISED HEARTH (ADD; EA)

Restrictions: Residential models only

This is a raised area in front of the fireplace opening, generally between 12 and 18 inches above floor level. It is usually some type of brick or other masonry material.

Cost does not include the fireplace or chimney.

VDI LOG LIGHTER (ADD; EA)

Restrictions: Residential models only

This addition is for the piping, outlet, and valve used to start or maintain a fire. Natural gas is the most common fuel used.

Cost does not include the fireplace or chimney.

VDM CHIMNEY FLUE, ADDITIONAL STORIES (ADD; EA Story Over 1)

Restrictions: Residential models only

This addition is for each extra story of chimney flue only, over the base of one included with component VDA. Costs do not include any firebox or hearth. For additional openings, use component VDP.

Costs are influenced by the type of flue, with prefabricated metal, precast concrete, and solid masonry materials, ascending in that order.

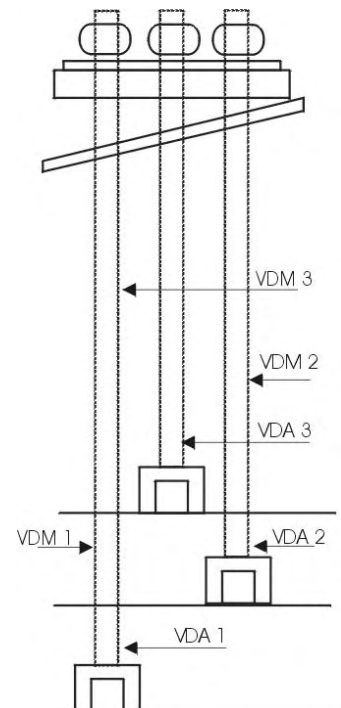

VDN CHIMNEY STACK, ADDITIONAL STORIES (ADD; EA Story Over 1)

Restrictions: Residential models only

This addition is for each extra story of chimney stack only over the base of one included with component VDF.

Rank is influenced by:

- Type and gauge of metal
- Diameter of stack
- Presence of multiple walls and insulation or fill
- Complexity of installation

VDP FIREPLACE OPENING (ADD; EA Opening Over 1)

Restrictions: Residential models only

This addition is for each extra firebox or hearth opening only, using a common chimney. They may be double (back-to-back hearth) or one over the other to form multiple combinations in conjunction with components VDA and VDM. Cost includes the firebox and hearth and wall area finishes, but no chimney.

Rank is influenced by the size of box or hearth and wall facings. For raised hearth, use component VDH.

VDVG FIREPLACE, DIRECT-VENTED GAS (UN-NUMBER OF UNITS)

Restrictions Residential Models only

This built-in gas fireplace is direct vented, which means it has a fixed glass front, which seals off the gas burner and combustion firebox from the home. 100% of the combustion air used by the fireplace comes from outside the home through a coaxial pipe. A smaller pipe inside the larger pipe eliminates all combustible gases, maintaining indoor air quality. The vent can be run horizontally through an outside wall, or vertically through the roof.

The costs include firebox opening (single for low-end, back-to-back for the higher-end), and a small-to-large hearth area with wall facings associated with the fireplace.

VE WOOD SHINGLE WALLS (SF Garage Wall Area)

Wood shingles which may have regular, irregular, or thatched butts. Consideration should be given to the amount of exposure each shingle has to the weather when selecting a rank. The less the amount of exposure, the higher the cost rank. Most bundles of shingles are furnished in random widths and applied over spaced sheathing and a building paper.

The shingles are thin, and small units are laid in overlapping layers.

Cost does not include interior finish.

Higher ranks include a pedestrian door and window.

VF BRICK VENEER WALLS (SF Garage Wall Area)

A brick, either common, face, or used, which has been applied to a wood frame structure to give it the appearance of a brick structure. The veneer is held to the wooden structure by small corrugated strips of metal fastened to the wood sheathing at the studs and embedded in mortar.

Cost does not include interior finish.

Higher ranks include a pedestrian door and window.

VG STONE VENEER WALLS (SF Garage Wall Area)

Stone veneer laid in either regular or irregular patterns attached to a frame wall through the use of metal clips.

Cost does not include interior finish.

Higher ranks include a pedestrian door and window.

VH BRICK WALLS (SF Garage Wall Area)

Masonry wall structure composed of common clay bricks only. Typically two rows thick, with each row grouted together. The structural requirements of the wall determine the thickness of the bed mortar joint, usually between 1/8 inch and 3/4 inch, while the design and structural requirements influence the type of bond used in the wall.

Cost does not include interior finish.

Higher ranks include a pedestrian door and window.

VI FACE BRICK WALLS (SF Garage Wall Area)

A solid masonry wall that has a face brick on the exterior and is typically backed with a concrete block or common brick.

Cost does not include interior finish.

Higher ranks include a pedestrian door and window.

VJ STONE WALLS (SF Garage Wall Area)

This wall may be composed of a stone that is the exterior face on a masonry wall backed with a concrete block, or it may be a solid stone wall laid in a random pattern.

Cost does not include interior finish.

Higher ranks include a pedestrian door and window.

VK CONCRETE BLOCK WALLS (SF Garage Wall Area)

Solid masonry wall built with one or two rows of concrete block and mortar. If used primarily as bearing walls, reinforcement exists. The amount of reinforcing varies due to the structural requirements of the wall. Reinforcing is laid horizontally with various courses and vertically in the hollow core of the concrete block.

Cost does not include interior finish.

Higher ranks include a pedestrian door and window.

VL INTERIOR FINISH ON WALL (ADD; SF Garage Wall Area)

This cost is for the interior finish on the exterior wall of the garage. The common wall should be included in the calculation of the wall area. The finish is commonly drywall. The better qualities may have some type of paneling or plaster used as the wall finish.

NOTE: Use with alternate method only.

VM GARAGE DOOR OPENER (EA)

This is a garage door opener with an electric motor. The motor size varies and it may be either a direct gear drive or screw drive. These openers have transmitters and receivers that are used for the operation.

VN SUPPORTING POSTS AND BEAMS, CARPORT (SF Carport Area)

For a built-in carport, this is the cost for wood posts used to support the floor or roof structure and the column footings that support the posts. The footings most commonly used are concrete.

VP SUPPORTING POSTS AND BEAMS (SF Breezeway Area)

This is the cost for wood posts used to support the roof structure and column footings for a breezeway. The footings most commonly used are concrete.

Cost does not include the roof.

WAA ORNAMENTAL SCREEN BLOCK WALL (SF Wall Area)

Fencing made of ornamental concrete screen block, reinforcing, and footings.

Use the following components for gates:

WCG Gate, Chain Link
WFG Gate, Wood
WMG Gate, Metal

WAB BRICK WALL (SF Wall Area)

Fencing made of brick, reinforcing, and footings.

Rank 1 for 8-inch brick.

Rank 4 for 12-inch brick.

Use the following components for gates:

WCG Gate, Chain Link
WFG Gate, Wood
WMG Gate, Metal

WAC CONCRETE BLOCK WALL (SF Wall Area)

Concrete block fencing. The cost includes reinforcing and footings.

Rank 1 for 4-inch block.

Rank 4 for 8-inch block.

Use the following components for gates:

WCG Gate, Chain Link
WFG Gate, Wood
WMG Gate, Metal

WACS CONCRETE BLOCK WALL, SUBDIVISIONS (SF Wall Area)

Exterior fencing composed of concrete block, including reinforcing and footings, put up in large quantities or subdivision construction with nonunion labor.

Rank 1 for 4-inch block.

Rank 4 for 8-inch block.

Use the following components for gates:

WCG Gate, Chain Link
WFG Gate, Wood
WMG Gate, Metal

WAD CONCRETE BLOCK WALL WITH STUCCO (SF Wall Area)

Fencing made of concrete block with stucco, reinforcing, and footings.

Rank 1 for 4-inch block with stucco on one side.
Rank 4 for 8-inch block with stucco on both sides.

Use the following components for gates:

WCG Gate, Chain Link
WFG Gate, Wood
WMG Gate, Metal

WADS CONCRETE BLOCK WALL WITH STUCCO, SUBDIVISIONS (SF Wall Area)

Exterior fencing composed of concrete block with stucco cover, including reinforcing and footings, put up in large quantities or subdivision construction with nonunion labor.

Rank 1 for 4-inch block with stucco on one side.
Rank 4 for 8-inch block with stucco on both sides.

Use the following components for gates:

WCG Gate, Chain Link
WFG Gate, Wood
WMG Gate, Metal

WAP APPLE TREES (EA Acre)

Restrictions: Model 441-3 only

Apple trees are considered improvements and should be valued in addition to the land when they mature. Apple trees are mature in the fourth year after planting.

See the agricultural manual for a complete discussion.

WAS SLUMP STONE BLOCK WALL (SF Wall Area)

Fencing made of concrete slump block, reinforcing and footings.

Use the following components for gates:

WCG Gate, Chain Link
WFG Gate, Wood
WMG Gate, Metal

WBR BARBECUE, BRICK-BLOCK (EA)

A complete brick or block barbecue.

Rank 1 is for simple design and construction with minimum steelwork.

Rank 2 is for average design and construction with a good grill.

Rank 3 is for good design and construction with a good grill and electric spit.

Rank 4 is for good design and construction with a heavy duty spit, sink, and many extras.

WCB BARBED WIRE (ADD; LF)

Use this component for the added cost of three strands of barbed wire on the top of a fence.

WCD BARBED COIL (ADD; LF)

Use this component for the added cost of barbed coil on the top of a fence.

WCG GATE, CHAIN LINK (SF Gate Area)

Chain link gate that allows passage through a fence. Hardware is included in the cost.

Rank 1 for swing gates 12 feet wide or less.

Rank 2 for rolling gates.

WCH CHRISTMAS TREES (EA Acre)

Restrictions: Model 446-3 only

Christmas trees are considered improvements and should be valued in addition to the land when they mature. Christmas trees are considered to be mature in the third year after planting.

See the agricultural manual for a complete discussion.

WCI CITRUS TREES (EA Acre)

Restrictions: Model 431-3 only

Citrus trees are considered improvements and should be valued in addition to the land when they mature. Citrus trees are mature in the fifth year after planting.

See the agricultural manual for a complete discussion.

WCL CHAIN LINK FENCE (SF Fence Area)

A fence made of metal wire mesh, posts and rails.

Rank is influenced by the gauge of the wire, overall height, and the spacing of the supporting posts and rails.

Barbed wire (component WCB) or barbed coil (component WCD) can be added to the top of this fence.

Use the following components for gates:

WCG Gate, Chain Link

WFG Gate, Wood

WMG Gate, Metal

WCV CHAIN LINK FENCE, VINYL COATED (SF Fence Area)

A fence made of metal wire fabric coated with vinyl and vertical posts.

Rank 1 for 6-foot high fence.

Rank 4 for 16-foot high fence.

Use the following components for gates:

WCG Gate, Chain Link

WFG Gate, Wood

WMG Gate, Metal

WDA DATE TREES (EA Acre)

Restrictions: Model 445-3 only

Date trees are considered improvements and should be valued in addition to the land when mature. The date trees are considered to be mature in the fifth year after planting.

See the Agricultural Manual for a complete discussion.

WEL WATER WELL (LF of Pipe)

Average cost of water wells 100 to 1,000 feet deep. Cost includes drilling, casings, gravel pack, set-up, testing, and miscellaneous costs up to point of actual operation excluding pumps.

Rank 1 for 4 to 6-inch casing.

Rank 2 for 8 to 10-inch casing.

Rank 3 for 12 to 14-inch casing.

Rank 4 for 16 to 18-inch casing.

WFA SOLID WOOD BOARD FENCE (LF)

A fence made of solid wood boards with horizontal rails and vertical posts.

Rank 1 for 5-foot high fence.

Rank 4 for 6-foot high fence.

Use the following components for gates:

WCG Gate, Chain Link

WFG Gate, Wood

WMG Gate, Metal

WFB WOOD BASKET WEAVE FENCE (LF)

A fence made of wood boards joined diagonally to form a checkered pattern similar to that of a woven basket. Posts are included in the cost.

Rank 1 for 5-foot high fence.

Rank 4 for 6-foot high fence.

Use the following components for gates:

WCG Gate, Chain Link

WFG Gate, Wood

WMG Gate, Metal

WFC WOOD, SPLIT RAIL FENCE (LF)

A fence made of wood rails and vertical posts.

Rank 1 for 2 rails.

Rank 4 for 4 rails.

Use the following components for gates:

WCG Gate, Chain Link

WFG Gate, Wood

WMG Gate, Metal

WFG GATE, WOOD (SF Gate Area)

A wooden gate that allows passage through a fence. The cost includes hardware.

WFP WOOD PICKET FENCE (LF)

A fence made of vertical piles supported by horizontal rails. The tops of the piles are often sharpened.

Rank 1 for 12- to 24-inch high fence.

Rank 4 for 50- to 60-inch high fence.

Use the following components for gates:

WCG Gate, Chain Link

WFG Gate, Wood

WMG Gate, Metal

WFR SPLIT REDWOOD FENCE (LF)

A solid fence made of split redwood pilings that are supported by horizontal rails. The pilings form a grape stake pattern.

Rank 1 for 5-foot high fence.

Rank 4 for 6-foot high fence.

Use the following components for gates:

WCG Gate, Chain Link

WFG Gate, Wood

WMG Gate, Metal

WFS WOOD STOCKADE FENCE (LF)

A fence made of round poles or timbers supported by horizontal rails.

Rank 1 for half poles.

Rank 4 for whole poles.

WGR VINEYARDS (EA Acre)

Restrictions: Model 421-3 only

Vineyards are considered improvements and should be valued in addition to the land when mature. Vineyards are mature in the fourth year after planting.

See the agricultural manual for a complete discussion.

WJO JOJOBA PLANTS (EA Acre)

Restrictions: Model 444-3 only

Jojoba plants are considered improvements and should be valued in addition to the land when mature. Jojoba plants are considered to be mature in the eighth year after planting.

See the agricultural manual for a complete discussion.

WLT LEMON TREES (EA Acre)

Restrictions: Model 431–3 only

Lemon trees are considered improvements and should be valued in addition to the land when mature. Lemon trees are considered to be mature in the fifth year after planting.

See the agricultural manual for a complete discussion.

WMF DECORATIVE METAL FENCE (SF Fence Area)

This fence can be made of hand-forged wrought iron, modular steel or aluminum. Footings are included in the cost.

Ranks 1 and 2 for stock fence.
Ranks 3 and 4 for custom fence.

Use the following components for gates:

WCG Gate, Chain Link
WFG Gate, Wood
WMG Gate, Metal

WMG GATE, METAL (SF Gate Area)

Ornamental metal gate that allows passage through a fence. The cost includes hardware.

WMR GUARDRAIL (LF)

A protective rail, such as those found on highways, constructed with 12 1/2 inches of metal rail and 10" x 10" wood posts.

Ranks 1 and 2 for installations over 1 mile.
Ranks 3 and 4 for installations under 1 mile.

WNP PECAN TREES (EA Acre)

Restrictions: Model 443–3 only

Pecan trees are considered improvements and should be valued in addition to the land when they are mature. Pecan trees are mature in the eighth year after planting.

See the agricultural manual for a complete discussion.

WNU NUT TREES (EA Acre)

Restrictions: Model 442-3 only

Nut trees are considered improvements and should be valued in addition to the land when they are mature. Nut trees are mature in the eighth year after planting.

See the agricultural manual for a complete discussion.

WOLV OLIVE TREES (EA Acre)

Restrictions: Model 445-3 only

Olive trees are considered improvements and should be valued in addition to the land when mature. Olive trees are mature in the fifth year after planting.

WOT ORANGE TREES (EA Acre)

Restrictions: Model 431-3 only

Orange trees are considered improvements and should be valued in addition to the land when they are mature. Orange trees are mature in the fifth year after planting.

See the agricultural manual for a complete discussion.

WOTM ORANGE TREES, MINNEOLA (EA Acre)

Restrictions: Model 431-3 only

Minneola orange trees are considered improvements and should be valued in addition to the land when they are mature. Minneola orange trees are mature in the fifth year after planting.

See the agricultural manual for a complete discussion.

WOTN ORANGE TREES, NAVEL (EA Acre)

Restrictions: Model 431-3 only

Navel orange trees are considered improvements and should be valued in addition to the land when they are mature. Navel orange trees are mature in the fifth year after planting.

See the agricultural manual for a complete discussion.

WPEV PRIVACY FENCE, VINYL (LF)

A privacy fence made of solid vinyl boards, rails and posts.

Rank 1 for 5 feet high.

Rank 4 for 6 feet high.

WPFV PICKET FENCE, VINYL (LF)

A solid vinyl fence made up of vertical piles supported by horizontal rails. The tops of the piles are often pointed.

Rank 1 for 12 to 24 inches high.

Rank 4 for 50 to 60 inches high.

WPG PINK GRAPEFRUIT TREES (EA Acre)

Restrictions: Model 431–3 only

Pink grapefruit trees are considered improvements and should be valued in addition to the land when they are mature. Pink grapefruit trees are mature in the fifth year after planting.

See the agricultural manual for a complete discussion.

WPGV GATE, VINYL (SF)

A solid vinyl gate that allows passage through a fence. The cost includes hardware.

WSF STONE FRUIT TREES (EA Acre)

Restrictions: Model 441–3 only

Stone fruit trees are considered improvements and should be valued in addition to the land when they are mature. Stone fruit trees are mature in the fourth year after planting.

See the agricultural manual for a complete discussion.

WTA TANGELO TREES (EA Acre)

Restrictions: Model 431–3 only

Tangelo trees are considered improvements and should be valued in addition to the land when they are mature. Tangelo trees are mature in the fifth year after planting.

See the agricultural manual for a complete discussion.

WTT TANGERINE TREES (EA Acre)

Restrictions: Model 431-3 only

Tangerine trees are considered improvements and should be valued in addition to the land when they are mature. Tangerine trees are mature in the fifth year after planting.

See the agricultural manual for a complete discussion.

WW RAMMED EARTH, COMMERCIAL (SF Wall Area)

Thickness range: 18-36" Required in miscellaneous field.

A solid masonry wall made of a mixture of earth and aggregate that has been compressed and dried. The cost includes exterior stucco finish, bond beam, and windows and doors appropriate to the model and overall building rank.

WWG WHITE GRAPEFRUIT TREES (EA Acre)

Restrictions: Model 431-3 only

White grapefruit trees are considered improvements and should be valued in addition to the land when they are mature. White grapefruit trees are mature in the fifth year after planting.

See the agricultural manual for a complete discussion.

WX RAMMED EARTH, RESIDENTIAL (SF Wall Area)

Thickness range: 18-36" Required in miscellaneous field.

A solid masonry wall made of a mixture of earth and aggregate, which has been compressed and dried. The cost includes exterior stucco finish, bond beam, and windows and doors appropriate to the model and overall building rank.

WXA BASE FEEDLOT (EA Animal Unit)

Restrictions: Model 491–3 only

This component covers the cost for a minimal feedlot. The component includes wood feed troughs, wood neck rails, wood corrals, water piping and water troughs.

Add for such items as concrete feed troughs (WXB), Concrete Aprons (WXC), Asphalt Feed Lanes (WXF), Sun Shades (WXD), Succor Rod Post and Rail Corrals (WXE), and Sprinklers (WXG).

WXB CONCRETE FEED TROUGH (ADD; EA Animal Unit)

Restrictions: Model 491–3 only

This component covers the additional cost of concrete troughs over the wood feed troughs already included in the base feed lot component.

WXC CONCRETE APRON (ADD; EA Animal Unit)

Restrictions: Model 491–3 only

Add for concrete aprons.

WXD SUN SHADES (ADD; EA Animal Unit)

Restrictions: Model 491–3 only

Add for sun shades.

WXE SUCCOR ROD POST AND RAIL CORRALS (ADD; EA Animal Unit)

Restrictions: Model 491–3 only

This component covers the additional cost of succor rod post and rail corrals over the wood corrals already included in the base feedlot component.

WXF ASPHALT FEED LANES (ADD; EA Animal Unit)

Restrictions: Model 491–3 only

Add for asphalt feed lanes.

WXG SPRINKLERS (ADD; EA Animal Unit)

Restrictions: Model 491–3 only

Add for sprinklers.

WXH CONCRETE DIPPING VAT (LF of Tank)

A recessed pit in ground filled with water and chemicals for the purpose of disinfecting cattle. Cost includes excavation, floor, walls and floor drain. Pumps, valves and other piping not included.

WXI CORRAL LOADING CHUTE (EA)

A wood ramp used to load cattle from a holding pen to truck or rail car.

The following influence rank:
—Quality of material

Rank 1 for open sides.
Rank 4 for solid sides.

WY STUCCO ON STANDARD BLOCK (SF Wall Area)

Thickness Range: 6"–36" Required in miscellaneous field.

A solid masonry wall made of standard concrete blocks and mortar with stucco exterior facing. The blocks are rectangular in shape and typically have inner openings (cores). These cores reduce the weight of the block as well as provide a space for reinforcing bars. Cost includes reinforcing (where necessary) and windows and doors appropriate to the given model and overall building rank.

Rank is influenced by:
—Quantity and quality of windows and doors
—Quality of material and workmanship of exterior and interior wall finishes

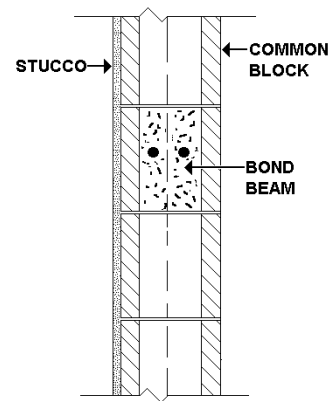

WZ STUCCO ON CAVITY BLOCK (SF Wall Area)

Thickness Range: 6"–36" Required in miscellaneous field.

Two single walls, with exterior stucco facing, constructed of standard concrete block and separated by an air space. Ties hold the walls together and in the higher ranks the cavity is grouted and reinforced. The cost includes reinforcing (where necessary) and windows and doors appropriate to the given model and overall building rank.

Rank is influenced by:
—Interior finish, lower ranks have no finish while higher ranks have drywall or plaster interior finish
—Quantity and quality of windows and doors

XA CONCRETE, PRECAST (SF Wall Area)

Thickness Range: 4"–14" Required in miscellaneous field.

A curtain wall (non-load-bearing) made of precast concrete panels. The panels can be ribbed, T-type, or flat plate, attached to a metal or concrete frame. Generally used in large one-story structures (industrial shell buildings). The cost includes windows and doors appropriate to the given model and overall building rank.

Rank is influenced by:

- Quantity and quality of windows and doors
- Quality of material and workmanship of exterior and interior wall finishes

XB BUTTRESS, BRICK (CF Buttress Area)

A short pierlike structure made of brick that is attached to an exterior wall at a right angle. Its function is to give greater strength and stability to the main wall.

XBA BUTTRESS, CONCRETE (CF Buttress Area)

A short pierlike structure made of concrete that is attached to an exterior wall at a right angle. Its function is to give greater strength and stability to the main wall.

XC BUTTRESS, GRANITE (CF Buttress Area)

A short pierlike structure made of granite that is attached to an exterior wall at a right angle. Its function is to give greater strength and stability to the main wall.

XD BUTTRESS, LIMESTONE (CF Buttress Area)

A short pierlike structure made of limestone that is attached to an exterior wall at a right angle. Its function is to give greater strength and stability to the main wall.

XE BUTTRESS, LOCAL STONE (CF Buttress Area)

A short pierlike structure made of local stone that is attached to an exterior wall at a right angle. Its function is to give greater strength and stability to the main wall.

XF BUTTRESS, MARBLE (CF Buttress Area)

A short pierlike structure made of marble that is attached to an exterior wall at a right angle. Its function is to give greater strength and stability to the main wall.

XG GRANITE (SF Wall Area)

Thickness Range: 6"–36" Required in miscellaneous field.

An exterior wall with a solid granite stone finish. The cost includes windows and doors appropriate to the overall building rank and an interior wall finish.

Stained glass is not included in the cost.

Rank is influenced by:

- Quantity and quality of windows and doors
- Quality of material and workmanship of exterior and interior wall finishes

XH LIMESTONE (SF Wall Area)

Thickness Range: 6"–36" Required in miscellaneous field.

An exterior wall with a solid limestone finish. The cost includes windows and doors appropriate to the overall building rank and an interior wall finish.

Stained glass windows are not included in the cost.

Rank is influenced by:

- Quantity and quality of windows and doors
- Quality of material and workmanship of exterior and interior wall finishes

XI STONE, LOCAL (SF Wall Area)

Thickness Range: 6"–36" Required in miscellaneous field.

An exterior wall with a solid local stone finish. The cost includes windows and doors appropriate to the overall building rank and an interior wall finish.

Stained glass is not included in the cost.

Rank is influenced by:

- Quantity and quality of windows and doors
- Quality of material and workmanship of exterior and interior wall finishes

XJ MARBLE (SF Wall Area)

Thickness Range: 6"–36" Required in miscellaneous field.

An exterior wall with a solid marble stone finish. The cost includes windows and doors appropriate to the overall building rank and an interior finish.

Stained glass is not included.

Rank is influenced by:

- Quantity and quality of windows and doors
- Quality of material and workmanship of exterior and interior wall finishes

XU ADOBE (SF Wall Area)

Thickness Range: 6"–12" Required in miscellaneous field.

The exterior wall made of masonry adobe block. The cost includes mortar, reinforcing (where necessary), and windows and doors appropriate to the given model and overall building rank.

Rank is influenced by:

- Interior finish: lower ranks have no finish, while higher ranks have drywall or plaster interior finish
- Quantity and quality of windows and doors

XUM ADOBE, MUD (SF Wall Area)

A building material made of sun-dried earth and straw.

XV CLAY BLOCK, HOLLOW (SF Wall Area)

Thickness Range: 6"–12" Required in miscellaneous field.

The exterior wall made of hollow clay block. Cost includes mortar, reinforcing (where necessary), and windows and doors appropriate to the given model and overall building rank.

Rank is influenced by:

- Interior finish: lower ranks have no finish, while higher ranks have drywall or plaster interior finish
- Quantity and quality of windows and doors

XW CONCRETE BLOCK, CAVITY (SF Wall Area)

Thickness Range: 8"–12" Required in miscellaneous field.

Two single walls constructed of standard concrete block and separated by an air space. Ties hold the walls together and in the higher ranks, the cavity is grouted and reinforced. The cost includes mortar, reinforcing (where necessary), and windows and doors appropriate to the given model and overall building rank. For face block, add component MEA. For glazed tile face, add component MAB.

Rank is influenced by:

- Interior finish: lower ranks have no finish, while higher ranks have drywall or plaster interior finish
- Quantity and quality of windows and doors

XX CONCRETE BLOCK, SLUMP STONE (SF Wall Area)

Thickness Range: 6"–36" Required in miscellaneous field.

A solid masonry wall made of slump stone concrete block. Typically these walls are 8 to 12 inches thick. The cost includes mortar, reinforcing (where necessary), and windows and doors appropriate to the given model and overall building rank.

Rank is influenced by:

- Quantity and quality of windows and doors
- Quality of material and workmanship of exterior and interior wall finishes

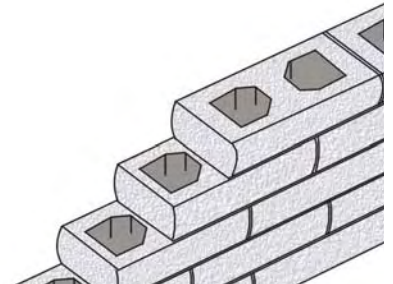

XY CONCRETE BLOCK, CAVITY SLUMP STONE (SF Wall Area)

Thickness Range: 8"–12" Required in miscellaneous field.

Two single walls constructed of concrete slump stone block separated by air space. The walls are held together by ties placed in the mortar bed joints of the structure at various intervals. The air space provides a barrier against the penetration of moisture to the inner side of the wall and in the higher ranks, is grouted and reinforced. The cost includes mortar, reinforcing (where necessary), and windows and doors appropriate to the given model and overall building rank.

Rank is influenced by:

- Quantity and quality of windows and doors
- Quality of material and workmanship of exterior and interior wall finishes

XZ BRICK, CAVITY, BLOCK BACKUP (SF Wall Area)

Thickness Range: 4"–36" Required in miscellaneous field.

An exterior wall made of common brick with a standard concrete block backup with an air space cavity in between. Ties hold the walls together and in the higher ranks, the cavity is grouted and reinforced. The cost includes mortar, reinforcing (where necessary), and windows and doors appropriate to the given model and overall building rank.

For face brick, add component ME.

Rank is influenced by:

- Interior finish: lower ranks have no finish, while higher ranks have drywall or plaster interior finish
- Quantity and quality of windows and doors

YA SERVICE STATION, STEEL FRAME (SF)

Restrictions: Models 171-x and 172-x only
300–4,000 SF only

Complete steel frame automobile service station. The cost includes foundation, floor, framing, exterior walls, fenestration, garage doors, roof, electrical, and plumbing.

Cost does not include canopies, equipment, heating, site improvements, and signs.

Rank is influenced by:

- Wall finish: Rank 1 for painted steel.
Rank 4 for porcelainized enamel.
- Wall height: Rank 1 for 9–10 feet.
Rank 4 for 12–14 feet.
- Built-in features: Number and type of storage cabinets, workbenches, and display racks should be considered when determining rank.
- Plumbing: Rank 1 has 4 residential-type fixtures.
Rank 4 has 7 to 9 good commercial grade fixtures.

YB SERVICE STATION, WOOD FRAME (SF)

Restrictions: Models 171-x and 172-x only
300–4,000 SF only

Complete wood frame automobile service station. The cost includes foundation, floor, framing, exterior walls, fenestration, garage doors, roof, electrical, and plumbing.

Cost does not include canopies, equipment, heating, site improvements, or signs.

Rank is influenced by:

- Wall finish: Rank 1 for concrete block.
Rank 4 for brick with block backup.
- Wall height: Rank 1 for 9–10 feet.
Rank 4 for 12–14 feet.
- Built-in features: Number and type of storage cabinets, workbenches, and display racks should be considered when determining rank.
- Plumbing: Rank 1 has 2 to 3 residential-type fixtures.
Rank 4 has 7 to 9 good commercial-grade fixtures.

YC SERVICE STATION, MASONRY (SF)

Restrictions: Models 171-x and 172-x only
300–4,000 SF only

Complete masonry bearing wall automobile service station. The cost includes foundation, floor, exterior walls, fenestration, garage doors, roof, electrical, and plumbing.

Cost does not include canopies, equipment, heating, site improvements, or signs.

Rank is influenced by:

- Wall finish: Rank 1 for concrete block.
Rank 4 for brick with block backup.
- Wall height: Rank 1 for 9–10 feet.
Rank 4 for 12–14 feet.
- Built-in features: Number and type of storage cabinets, workbenches, and display racks should be considered when determining rank.
- Plumbing: Rank 1 has 4 residential-type fixtures.
Rank 4 has 7 to 9 good commercial-grade fixtures.

YGA GREENHOUSE, STRAIGHT WALL, CURTAIN (SF)

Restrictions: Commercial Greenhouse only
500–500,000 SF

Complete greenhouse with fiberglass panels and roll-up curtain walls composing the walls and fiberglass panel roof on a straight framed wall (wall height is 8 feet). The cost includes foundations, framing, wall and roof panels and wall curtain, lighting, water service, ventilation openings, doors, and fasteners.

Cost does not include floor, stem wall, heating and cooling, or plumbing.

Panel thickness should be considered when determining a rank: the thicker the panel, the higher the rank.

- Rank 1 for wood or pipe frame.
- Rank 2 for average steel frame.
- Rank 3 for good aluminum or galvanized steel frame.
- Rank 4 for high quality aluminum or galvanized steel frame.

YGB GREENHOUSE, STRAIGHT WALL, FIBERGLASS (SF)

Restrictions: Commercial Greenhouse only
500–500,000 SF

Complete greenhouse with fiberglass panels composing the walls and roof on a straight framed wall (wall height is 8 feet). The cost includes foundations, framing, wall and roof panels, lighting and water service, ventilation openings, doors, and fasteners.

Cost does not include floor, stem wall, heating and cooling, or plumbing.

Panel thickness should be considered when determining a rank: the thicker the panel, the higher the rank.

Rank 1 for wood or pipe frame.

Rank 2 for average steel frame.

Rank 3 for good aluminum or galvanized steel frame.

Rank 4 for high quality aluminum or galvanized steel frame.

YGC GREENHOUSE, STRAIGHT WALL, GLASS (SF)

Restrictions: Commercial Greenhouse only
500–500,000 SF

Complete greenhouse with glass panels composing the walls and roof on a straight framed wall (wall height is 8 feet). The cost includes foundations, framing, wall and roof panels, lighting service, water service, ventilation openings, doors, and fasteners.

Cost does not include floor, stem wall, heating and cooling, or plumbing.

Panel thickness should be considered when determining a rank: the thicker the panel, the higher the rank.

Rank 1 for wood or pipe frame.

Rank 2 for average steel frame.

Rank 3 for good aluminum or galvanized steel frame.

Rank 4 for high quality aluminum or galvanized steel frame.

YGD GREENHOUSE, STRAIGHT WALL, PLASTIC, DOUBLE (SF)

Restrictions: Commercial Greenhouse only
500–500,000 SF

Complete greenhouse with double layer inflated plastic film composing the walls and roof on a straight framed wall (wall height is 8 feet). The cost includes foundations, framing, exterior film, lighting service, water service, ventilation openings, doors, and fasteners.

Cost does not include floor, stem wall, heating and cooling, or plumbing.

Film thickness should be considered when determining a rank: the thicker the film, the higher the rank.

Rank 1 for wood or pipe frame.

Rank 2 for average steel frame.

Rank 3 for good aluminum or galvanized steel frame.

Rank 4 for high quality aluminum or galvanized steel frame.

YGE GREENHOUSE, STRAIGHT WALL, PLASTIC, SINGLE (SF)

Restrictions: Commercial Greenhouse only
500–500,000 SF

Complete greenhouse with single layer plastic film composing the walls and roof on a straight framed wall (wall height is 8 feet). The cost includes foundations, framing, exterior film, lighting service, water service, ventilation openings, doors, and fasteners.

Cost does not include floor, stem wall, heating and cooling, or plumbing.

Film thickness should be considered when determining a rank: the thicker the film, the higher the rank.

Rank 1 for wood or pipe frame.

Rank 2 for average steel frame.

Rank 3 for good aluminum or galvanized steel frame.

Rank 4 for high quality aluminum or galvanized steel frame.

YGF GREENHOUSE, STRAIGHT WALL, STRUCTURAL POLYCARBONATE (SF)

Restrictions: Commercial Greenhouse only
500–500,000 SF

Complete greenhouse with structural honeycombed plastic sandwich panels composing the walls and roof on a straight framed wall (wall height is 8 feet). The cost includes foundations, framing, wall and roof panels, lighting service, water service, ventilation openings, doors and fasteners.

Cost does not include floor, stem wall, heating and cooling or plumbing.

Panel thickness should be considered when determining a rank: the thicker the panel, the higher the rank.

Rank 1 for wood or pipe frame.

Rank 2 for average steel frame.

Rank 3 for good aluminum or galvanized steel frame.

Rank 4 for high quality aluminum or galvanized steel frame.

YGJ GREENHOUSE, BOW, FIBERGLASS (SF)

Restrictions: Commercial Greenhouse only
500–500,000 SF

Complete greenhouse with fiberglass panels composing the exterior surface on a full bow framed structure. The cost includes foundations, framing, wall and roof panels, lighting service, water service, ventilation openings, doors, and fasteners.

Cost does not include floor, stem wall, heating and cooling, or plumbing.

Panel thickness should be considered when determining a rank: the thicker the panel, the higher the rank.

Rank 1 for wood or pipe frame.

Rank 2 for average steel frame.

Rank 3 for good aluminum or galvanized steel frame.

Rank 4 for high quality aluminum or galvanized steel frame.

YGK GREENHOUSE, BOW, PLASTIC, DOUBLE (SF)

Restrictions: Commercial Greenhouse only
500–500,000 SF

Complete greenhouse with double layer inflated plastic film composing the exterior cover on a full bow framed structure. The cost includes foundations, framing, exterior film, lighting service, water service, ventilation openings, doors, and fasteners.

Cost does not include floor, stem wall, heating and cooling, or plumbing.

Film thickness should be considered when determining a rank: the thicker the film, the higher the rank.

Rank 1 for wood or pipe frame.

Rank 2 for average steel frame.

Rank 3 for good aluminum or galvanized steel frame.

Rank 4 for high quality aluminum or galvanized steel frame.

YGL GREENHOUSE, BOW, PLASTIC, SINGLE (SF)

Restrictions: Commercial Greenhouse only
500–500,000 SF

Complete greenhouse with single layer plastic film composing the exterior cover on a full bow framed structure. The cost includes foundations, framing, wall and roof panels, lighting service, water service, ventilation openings, doors, and fasteners.

Cost does not include floor, stem wall, heating and cooling, or plumbing.

Film thickness should be considered when determining a rank: the thicker the film, the higher the rank.

Rank 1 for wood or pipe frame.

Rank 2 for average steel frame.

Rank 3 for good aluminum or galvanized steel frame.

Rank 4 for high quality aluminum or galvanized steel frame.

**YGM GREENHOUSE, BOW, STRUCTURAL
POLYCARBONATE (SF)**

Restrictions: Commercial Greenhouse only
500–500,000 SF

Complete greenhouse with structural honeycombed plastic sandwich panels composing the exterior cover on a full bow framed structure. The cost includes foundations, framing, wall and roof panels, lighting service, water service, ventilation openings, doors, and fasteners.

Cost does not include floor, stem wall, heating and cooling or plumbing.

Panel thickness should be considered when determining a rank: the thicker the panel, the higher the rank.

Rank 1 for wood or pipe frame.

Rank 2 for average steel frame.

Rank 3 for good aluminum or galvanized steel frame.

Rank 4 for high quality aluminum or galvanized steel frame.

YGR GREENHOUSE, MODIFIED BOW, FIBERGLASS (SF)

Restrictions: Commercial Greenhouse only
500–500,000 SF

Complete greenhouse with fiberglass panels composing the walls and roof on a modified bow framed wall (wall height is 3 feet). The cost includes foundations, framing, wall and roof panels, lighting service, water service, ventilation openings, doors, and fasteners.

Cost does not include floor, stem wall, heating and cooling, or plumbing.

Panel thickness should be considered when determining a rank: the thicker the panel, the higher the rank.

Rank 1 for wood or pipe frame.

Rank 2 for average steel frame.

Rank 3 for good aluminum or galvanized steel frame.

Rank 4 for high quality aluminum or galvanized steel frame.

YGS GREENHOUSE, MODIFIED BOW, PLASTIC, DOUBLE (SF)

Restrictions: Commercial Greenhouse only
500–500,000 SF

Complete greenhouse with double layer inflated plastic film composing the walls and roof on a modified bow framed wall (wall height is 3 feet). The cost includes foundations, framing, exterior film, lighting service, water service, ventilation openings, doors, and fasteners.

Cost does not include floor, stem wall, heating and cooling, or plumbing.

Film thickness should be considered when determining a rank: the thicker the film, the higher the rank.

Rank 1 for wood or pipe frame.
Rank 2 for average steel frame.
Rank 3 for good aluminum or galvanized steel frame.
Rank 4 for high quality aluminum or galvanized steel frame.

YGT GREENHOUSE, MODIFIED BOW, PLASTIC, SINGLE (SF)

Restrictions: Commercial Greenhouse only
500–500,000 SF

Complete greenhouse with single layer plastic film composing the walls and roof on a modified bow framed wall (wall height is 3 feet). The cost includes foundations, framing, exterior film, lighting service, water service, ventilation openings, doors, and fasteners.

Cost does not include floor, stem wall, heating and cooling, or plumbing.

Film thickness should be considered when determining a rank: the thicker the film, the higher the rank.

Rank 1 for wood or pipe frame.
Rank 2 for average steel frame.
Rank 3 for good aluminum or galvanized steel frame.
Rank 4 for high quality aluminum or galvanized steel frame.

**YGU GREENHOUSE, MODIFIED BOW, STRUCTURAL
POLYCARBONATE (SF)**

Restrictions: Commercial Greenhouse models only
500–500,000 SF

Complete greenhouse with structural honeycombed plastic sandwich panels composing the walls and roof on a modified bow framed wall (wall height is 3 feet). The cost includes foundations, framing, wall and roof panels, lighting service, water service, ventilation openings, doors, and fasteners.

Cost does not include floor, stem wall, heating and cooling, or plumbing.

Panel thickness should be considered when determining a rank: the thicker the panel, the higher the rank.

Rank 1 for wood or pipe frame.

Rank 2 for average steel frame.

Rank 3 for good aluminum or galvanized steel frame.

Rank 4 for high quality aluminum or galvanized steel frame.

YQA PRE-ENGINEERED QUONSET, COMMERCIAL (SF)

Restrictions: Commercial Quonset models only
Class S only
See description and rank table below.

YQB PRE-ENGINEERED QUONSET, INDUSTRIAL (SF)

Restrictions: Industrial Quonset models only
Class S only
See description and rank table below.

YQC PRE-ENGINEERED QUONSET, RURAL (SF)

Restrictions: Farm models only
Class S only
See description and rank table below.

Prefabricated metal building having a semicircular roof of corrugated metal that curves down to the ground forming the exterior walls. The cost includes concrete footings, shell with minimum fenestration and installation.

Floor, heating, electrical, and plumbing are not included in the cost.

Use the following table to select a rank:

LENGTH IN FEET	WIDTH IN FEET			
	30	40	60	70
30	4.0	—	—	—
36	3.6	—	—	—
48	3.1	3.6	—	—
60	2.8	3.3	3.7	—
72	2.4	2.9	3.4	3.5
84	2.3	2.7	3.1	3.3
96	1.9	2.4	2.9	3.0
108	1.7	2.3	2.7	2.9
120	1.5	2.1	2.5	2.7
160	1.0	1.7	2.0	2.1
200	—	1.2	1.6	1.7
240	—	1.0	1.2	1.5

YURT YURT TENT HOME (SF)

Restrictions: Model 018-x only
100 to 800 square feet

A prefabricated wood, steel, and vinyl Yurt tent home. The cost includes all wall and roof framing, fabric cover, insulation, door, windows, delivery, and labor. Floor, electric, plumbing, heating and cooling must be added, if present.

YWA CAR WASH EQUIPMENT ROOM, MASONRY (SF)

Restrictions: Model 175-x only

Masonry equipment room in a self-serve car wash. The cost includes walls, door, lighting, and plumbing.

The thickness of wall should be considered when selecting a rank.

YWB CAR WASH EQUIPMENT ROOM, STEEL (SF)

Restrictions: Model 175-x only

Steel panel equipment room in a self-serve car wash. The cost includes walls, door, lighting, and plumbing.

The gauge of the steel should be considered when selecting a rank.

YWC CAR WASH EQUIPMENT ROOM, WOOD FRAME—STUCCO (SF)

Restrictions: Model 175-x only

Wood frame with siding or stucco equipment room in a self-serve car wash. The cost includes walls, door, lighting, and plumbing.

The spacing of the studs, thickness of sheathing, and the quality of wall finish should be considered when selecting a rank.

YWD CAR WASH, MASONRY (SF)

Restrictions: Model 173-x only

Masonry building shell for a drive-thru car wash. The cost includes concrete slab, floor drains, basic electrical, lighting and water service, and equipment enclosure.

Rest room fixtures, cashier booth, and car wash equipment are not included in the cost.

The thickness of the walls, finish of walls and the complexity of building design should be considered when selecting a rank.

YWE CAR WASH, PORCELAINIZED STEEL (SF)

Restrictions: Model 173-x only

Porcelainized steel panel building shell for a drive-thru car wash. The cost includes concrete slab, floor drains, basic electrical, lighting and water service, and equipment enclosure.

Rest room fixtures, cashier booth, and car wash equipment are not included in the cost.

The gauge of the panel, the panel finish, and the complexity of building design should be considered when selecting a rank.

YWF CAR WASH, STEEL (SF)

Restrictions: Model 173-x only

Steel panel building shell for a drive-thru car wash. The cost includes concrete slab, floor drains, basic electrical, lighting and water service, and equipment enclosure.

Rest room fixtures, cashier booth and car wash equipment are not included in the cost.

The gauge of the panel, the panel finish and the complexity of building design should be considered when selecting rank.

YWG CAR WASH, WOOD FRAME STUCCO (SF)

Restrictions: Model 173-x only

Wood frame with siding or stucco building shell for a drive-thru car wash. The cost includes concrete slab, floor drains, basic electrical, lighting and water service, and equipment enclosure.

Rest room fixtures, cashier booth, and car wash equipment are not included in the cost.

The exterior cover, spacing of the studs and the complexity of building design should be considered when selecting a rank.

YWJ CAR WASH, MASONRY (SF)

Restrictions: Model 174-x only

Masonry building shell for an automatic car wash. The cost includes concrete slab, floor cover, floor drains, basic electrical, lighting and water service, finished office area, locker, rest rooms, and equipment room.

Canopies, car wash equipment, and ornamental pylons are not included in the cost.

Rank is influenced by the thickness and finish of walls and the complexity of the building design.

YWK CAR WASH, AUTOMATIC, PORCELAINIZED STEEL (SF)

Restrictions: Model 174-x only

Porcelainized steel panel building shell for an automatic car wash. The cost includes concrete slab, floor drains, basic electrical, lighting and water service, finished office area, locker, rest rooms, and equipment room. Canopies, ornamental pylons, and car wash equipment are not included in the cost.

The gauge and finish of the panel should be considered when selecting a rank.

YWL CAR WASH, AUTOMATIC, STEEL (SF)

Restrictions: Model 174-x only

Steel panel building shell for an automatic car wash. The cost includes concrete slab, floor drains, basic electrical, lighting and water service, finished office area, locker, rest rooms, and equipment room. Canopies, ornamental pylons, and car wash equipment are not included in the cost.

The gauge and finish of the panel should be considered when selecting a rank.

YWM CAR WASH, AUTOMATIC, WOOD FRAME—STUCCO (SF)

Restrictions: Model 174-x only

Wood frame with siding or stucco building shell for an automatic car wash. The cost includes concrete slab, floor drains, basic electrical, lighting and water service, finished office area, locker and rest rooms, and equipment room.

Canopies, ornamental pylons, and car wash equipment are not included in the cost.

The spacing of the studs, thickness of sheathing, and the quality of wall finish should be considered when selecting a rank.

**ARIZONA DEPARTMENT OF REVENUE
CONSTRUCTION COST MANUAL**

**VOLUME II
APPENDIX A**

GLOSSARY

-A-

ABSORPTION FIELD. A drainage system consisting of a series of pipes laid in trenches filled with sand, gravel, or crushed stone, through which septic tank effluent may seep or leach into the surrounding ground.

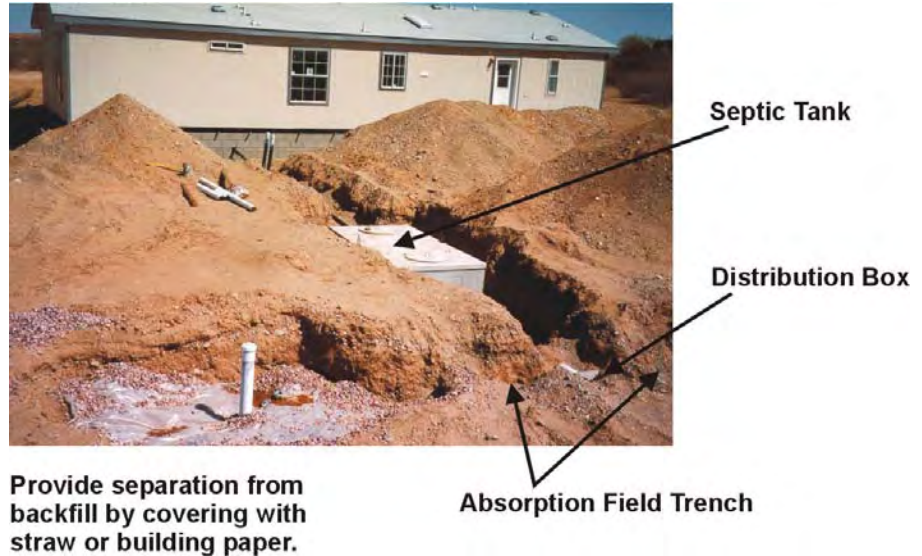

ABUTMENT. A foundation structure designed to withstand thrust, such as the end supports of an arch.

ACCESS FLOOR. See computer floor, elevated floor.

ACOUSTICAL CEILING. In general terms, a ceiling designed to lessen sound reverberation through absorption, blocking or muffling. In construction, the most common materials are acoustical tile and acoustical plaster.

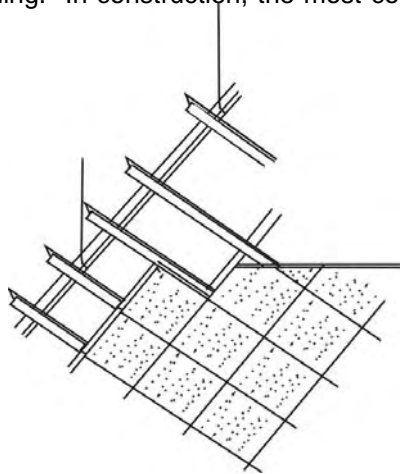

ACOUSTICAL PLASTER. A wall and ceiling plaster having sound-absorbing characteristics.

ACOUSTICAL TILE. A ceiling or wall tile finishing material with an inherent property to absorb sound; usually made of mineral, fiber, or insulated metal materials.

ALTERATION. Construction within a structure or to its exterior closure which does not change the overall dimensions. Alteration includes remodeling.

ANGLE IRON. L-shaped steel structural member classified by the thickness of the stock and the length of the legs.

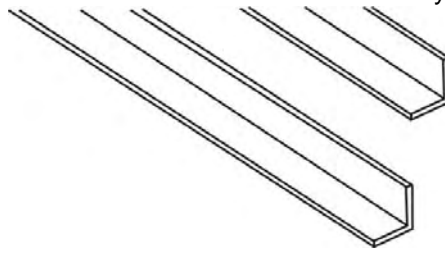

ANIMAL UNIT. The unit of measure for livestock based upon the amount of forage required for one 1,000-pound mature cow, either dry or with calf up to six months of age, or their equivalent.

ANODIZED ALUMINUM. Aluminum that has had a hard, corrosion-resistant, oxide film applied to it by an electrochemical process. A color anodizing process may be used to produce a number of colored finishes.

APPLIANCE ALLOWANCE. This cost includes consideration for the residential appliances commonly found at different quality levels. Typically, ranges and ovens, garbage disposers, dishwashers, and range hoods are included. The better qualities (higher cost ranks) have additional feature considerations for trash compactors, microwaves, built-in mixer units, etc.

APRON. A term usually applied to a surfaced area adjoining roads, driveways, buildings, airstrips, etc.

ARCHITECT. Designation reserved, usually by law, for a person or organization professionally qualified and duly licensed to perform architectural services, including but not limited to analysis of project requirements, creation and development of the project design, preparation of drawings, specifications, bidding requirements, and general administration of the construction contract.

ARCHITECTURAL FEE. The cost of architectural services to an owner, usually a percentage of the total contract. The fee varies according to the services provided and the complexity of the project.

ARCHITECTURE. The art and science of designing and building structures.

AREA. (1) A measurement of a given planar region or of the surface of a solid. (2) The surface of anything, measured in square units. (3) The number of square feet of surface in a structure calculated on the basis of outside measurements.

ARMORED CABLE. Electrical cable consisting of a flexible metal covering enclosing two or more wires, often referred to as BX cable.

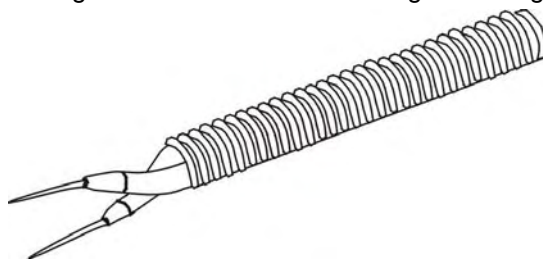

ASBESTOS SHINGLES. Fire-resistant shingles composed principally of asbestos fibers.

ASHLAR. A wall facing of masonry slabs (stone, terra cotta) applied over the bearing exterior walls.

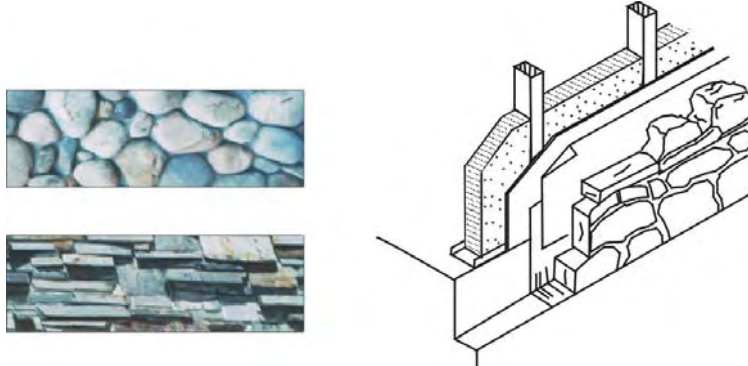

ASPHALT. A dark-brown to black bitumen pitch that melts readily. It appears in nature in asphalt beds and is also produced as a by-product of the petroleum industry.

ASPHALT FLOORING. Consists of limestone dust and coarse aggregate incorporated with either asphaltic bitumen or equal proportions of asphaltic bitumen and asphalt.

ASPHALT PREPARED ROOFING. Asphaltic felt, cold process roofing, prepared roofing, rolled roofing, rolled strip roofing, roofing felt, sanded bituminous felt, saturated felt, self-finished roofing felt. A roof covering that comes in rolls and is manufactured from asphalt impregnated felt with a harder surface or asphalt applied to the surface. All or part of the weather side may be covered with aggregate of various sizes and colors.

ASPHALT TILE. A resilient floor covering laid in mastic, available in several colors. Standard size is 9"x 9"; also comes in several other sizes. Asphalt is normally used only in the darker colors, the lighter colors having a resin base.

ATTACHED GARAGE. A car storage structure with one or two walls in common with the residence.

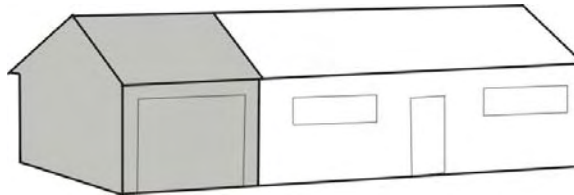

ATTIC. Accessible space between the roof rafters and ceiling joists.

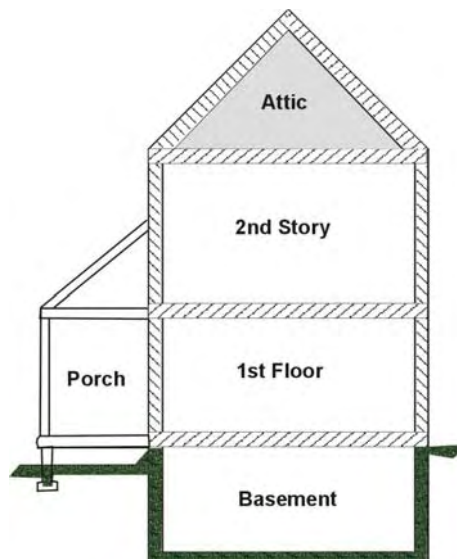

AWNING. A roof-like shelter extending over a doorway, window, or patio which provides protection from the sun or rain.

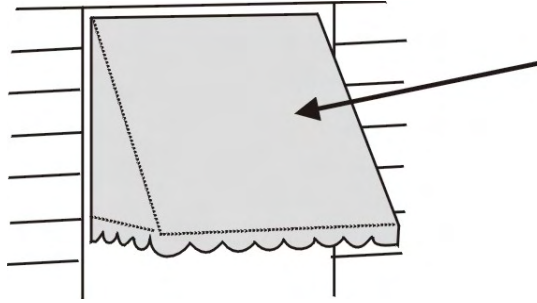

-B-

BACKFILL. The material used for refilling an excavation.

BACKING. Rough inner face of a wall; earth deposited behind a retaining wall; framing members that provide a means to install gypsum board or other bracing.

BACKUP. The inner load-bearing or structural portion of a masonry wall, usually finished with face brick, stone ashlar, stucco, or other decorative or protective veneer.

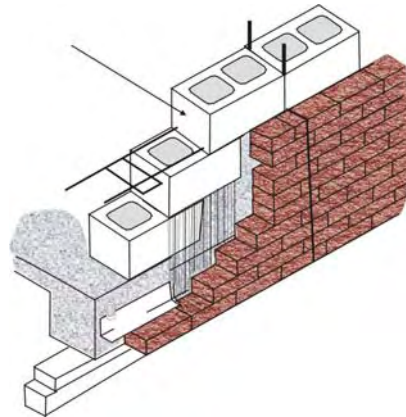

BALCONY. A balustraded or railed elevated platform projecting from the wall of a building, usually cantilevered or supported by columns.

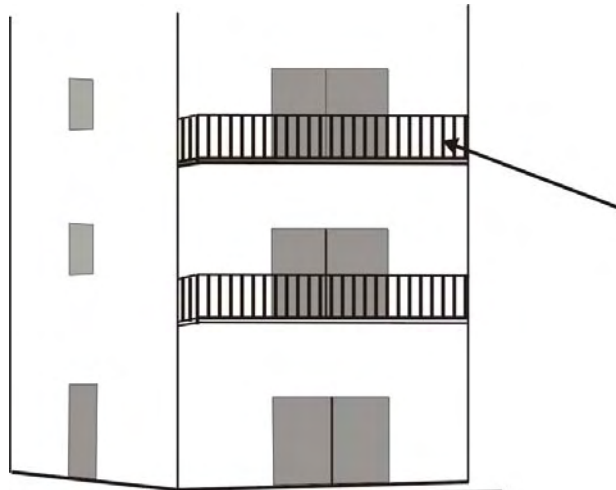

BALLOON FRAME. A framing system in a two story building in which studs and corner posts extend from the foundation sill to the roof top plate. Upper story floor joists are carried on ledgers or girts or nailed directly to the studs.

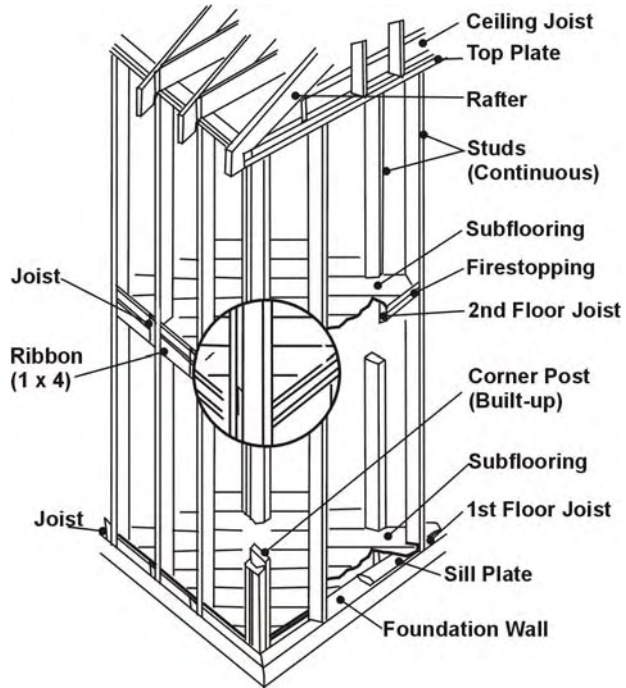

BALUSTRADE. Protective/Decorative railing with supportive balusters or banisters.

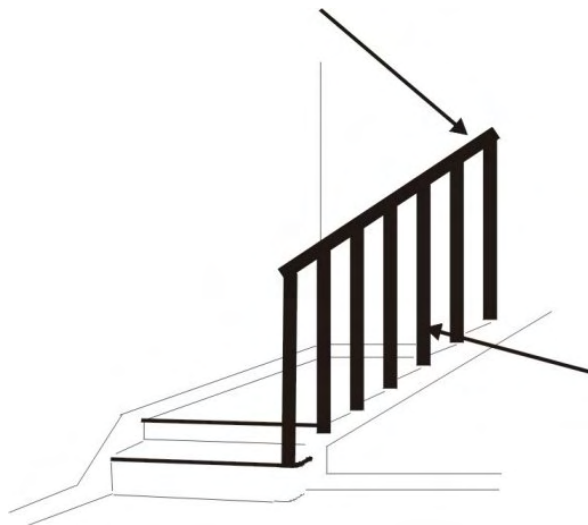

BALUSTER, BANISTER. The closely spaced vertical members in a stairway or balcony, balustrade or railing.

BAR JOIST. A light steel joist of open web construction with a single zigzagged bar welded to upper and lower chords at the points of contact and used as floor and roof supports.

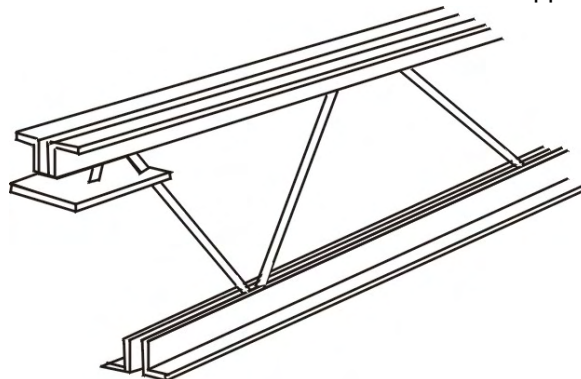

BARREL VAULTED DECK. Thin shell concrete or wood deck having the form of a series of half-cylinders joined at their edges and supported at their ends by the building walls or columns. Structurally, these may be a series of side-by-side "beams".

BASE. (1) The lowest part of anything upon which the whole rests. (2) A subfloor slab or "working mat" either previously placed and hardened or freshly placed, on which floor topping is placed. The base is the underlying stratum on which a concrete slab, such as pavement, is placed. (3) A board or molding used against the bottom of walls to cover their joint with the floor and to protect them from kicks and scuffs. The base is the protection covering the unfinished edge of plaster or gypsum board. (4) The lowest visible part of a building.

BASEBOARD. A horizontal decorative element used to cover the joint between a wall and floor.

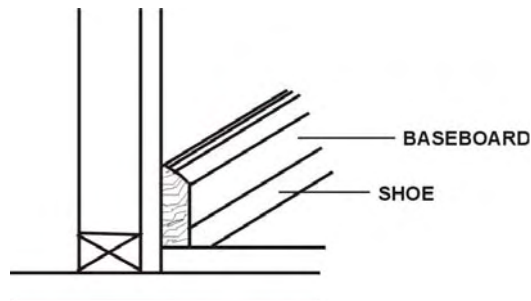

BASEBOARD HEAT. Heating in which the heating element, usually electric or forced hot water, is located along the base of the wall.

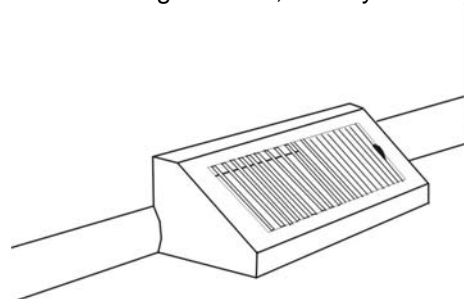

BASEMENT. A full story space below the first floor, partially or entirely below grade.

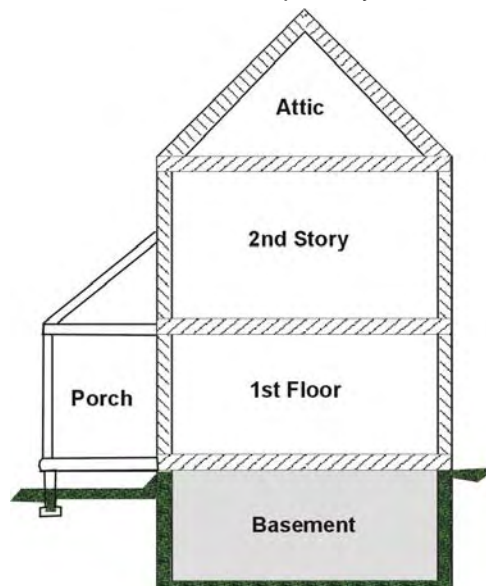

BATT INSULATION. Thermal or sound insulating material, such as fiberglass or expanded shale, which has been expanded into a flexible, blanket-like form and often has a vapor barrier on one side. Batt insulation is manufactured in dimensions that facilitate its installation between studs or joists.

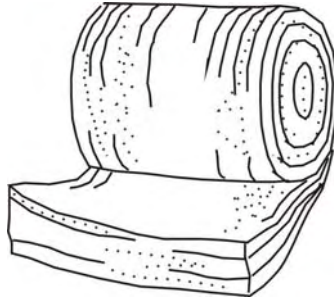

BATTEN. A narrow strip of wood or metal used to cover vertical joints between boards or panels.

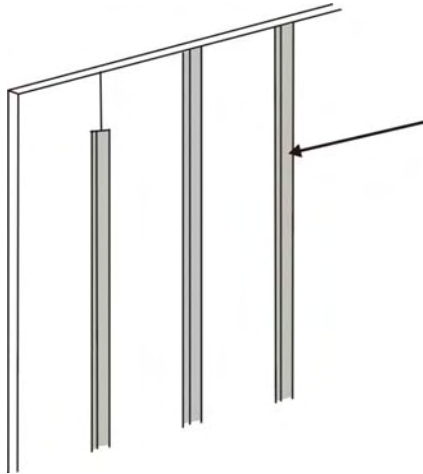

BAY. (1) In construction, the space between two main trusses or beams. (2) The space between two adjacent piers or mullions or between two adjacent lines of columns. (3) A small, well-defined area of concrete laid at one time in the course of placing large areas, such as floors, pavements, or runways. (4) The projecting structure of a bay window.

BAY WINDOW. An alcove of a room projecting from an outside wall and having its own windows and foundation. An aerial window is a similar structure but supported on projecting corbels.



BEAM. A principal load-supporting member of a building; may be of wood, steel, or concrete; transmits the load horizontally to vertical posts, columns, or bearing walls.

BEARING. That section of a structural member such as a beam or truss that rests on the supports. Any wall which provides support to the floor or roof of a building.

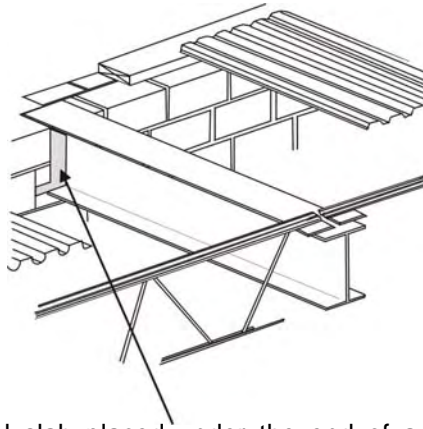

BEARING PLATE. A steel slab placed under the end of a beam, girder, truss, or column, to distribute the load over a wider surface.

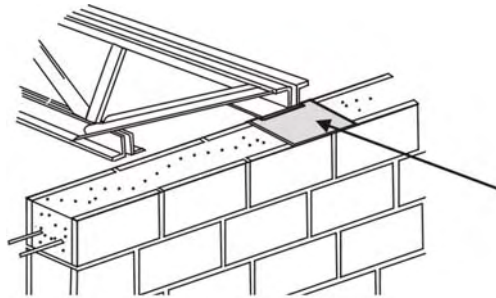

BEARING WALL. A wall which supports any vertical load in a building as well as its own weight.

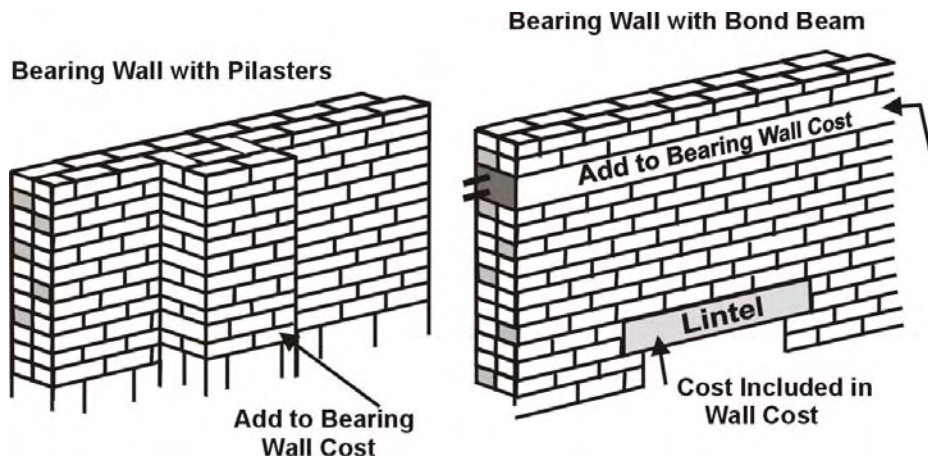

BENT. A rigid framing unit of a building, consisting of two columns and a horizontal truss, beam, or girder line or surface that joins another.

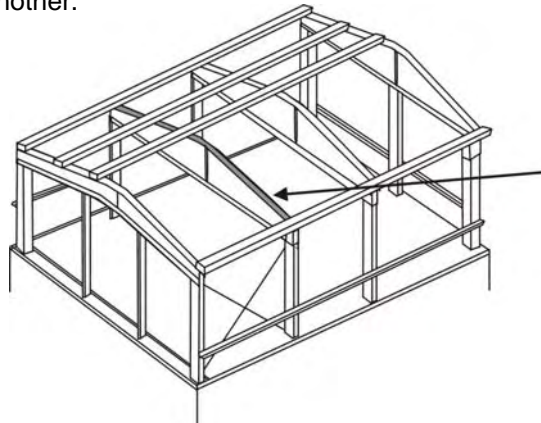

BEVEL. Any angle except a right angle, or inclination of any line or surface that joins another.

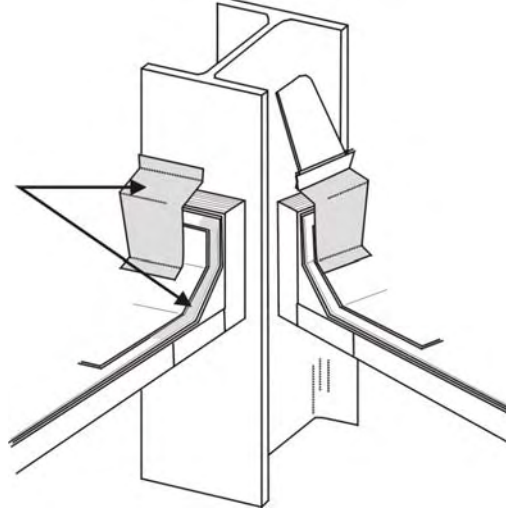

BEVELED WOOD SIDING. Siding boards of varying widths, with lower edges thicker than upper edges which are covered by the lower edge of the board above.

B-GRADE WOOD. The classification of a somewhat inferior grade of solid surface veneer which contains visible repair plugs and tight knots.

BIB VALVE. Any standard bibcock or faucet equipped with a handle that is turned to control the flow and screwed down to shut off the flow by closing a washer disk onto a seating within a valve.

BIBCOCK, BIB, BIBB, BIB TAP. (1) Any faucet or stopcock having its nozzle directed downward. (2) Any tap supplied by a horizontal pipe.

BIDET. A bathroom fixture used for hygienic washing of genitals and posterior parts.

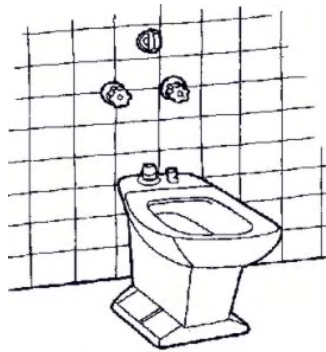

BI-LEVEL. A two-story building in which the first floor extends below grade, with the foundation wall serving as a portion of the exterior wall.

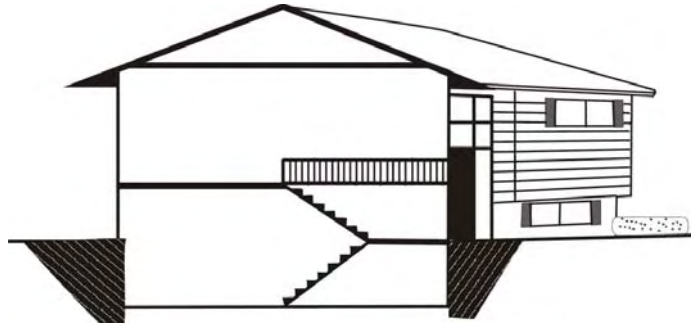

BLOCK. (1) A usually hollow concrete masonry unit or other building unit, such as glass. (2) A solid, often squared, piece of wood or other material. (3) A piece of wood nailed between joists to stiffen a floor. (4) Any small piece of wood secured to the interior angle joint to strengthen and stiffen it.

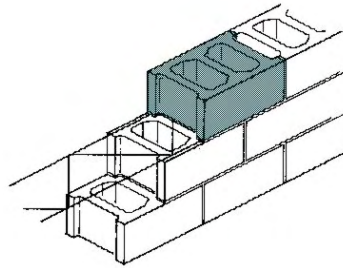

BLOCKWORK. Masonry of concrete block and mortar.

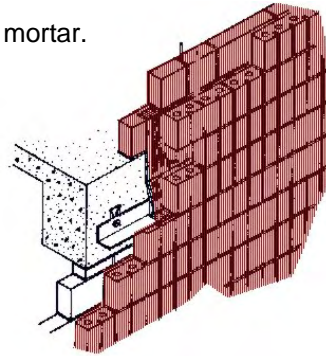

BOARD FOOT. A unit of measure represented by a board one foot long, one foot wide, and one inch thick.

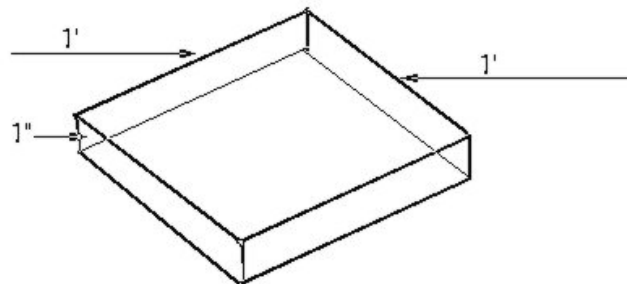

BOILER. Metal vessel for heating water or generating steam.

BOND. The arrangement of individual masonry units in a certain overlapping pattern to give the finished structural unit additional strength and to allow the individual elements to act together as a cohesive, integrated unit.

BOND BEAM. A horizontally reinforced concrete or concrete masonry beam built to strengthen and tie a masonry wall together. A bond beam is frequently placed at the top of a wall with continuous reinforcing around the entire perimeter.

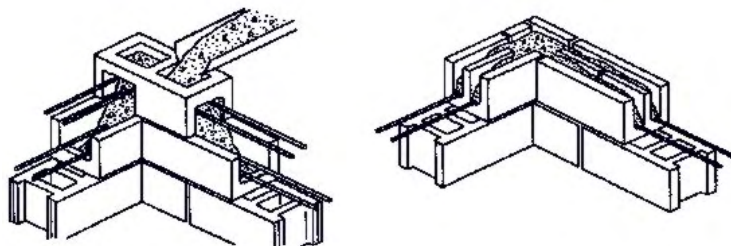

BRACE. Inclined structural member to reinforce frame, truss, or other structural members.

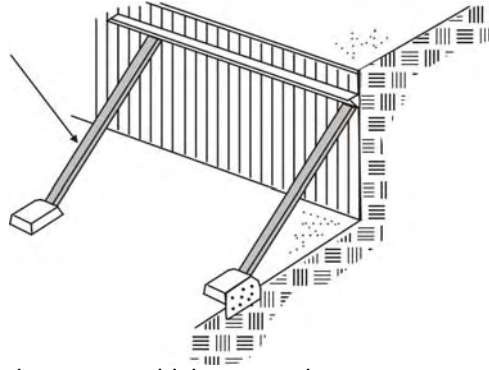

BREEZEWAY. A covered passage which passes between two structures.

BRICK, BLOCK BACKUP. A non-load-bearing single tier of brick applied to a wall of other materials.

BRICK CAVITY WALL. A wall in which a space is left between inner and outer tiers or wythes of brick. The space may be filled with insulation, grout, and/or reinforcing.

BRICK VENEER. A non-load-bearing single tier of brick applied to a wall of other materials.

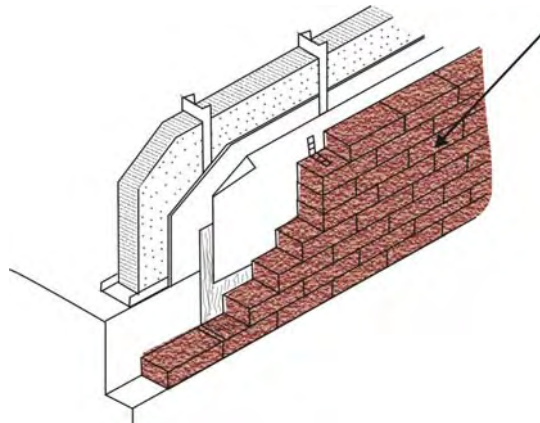

BRIDGING. A method of bracing floor joists by fixing lateral members between the joists.

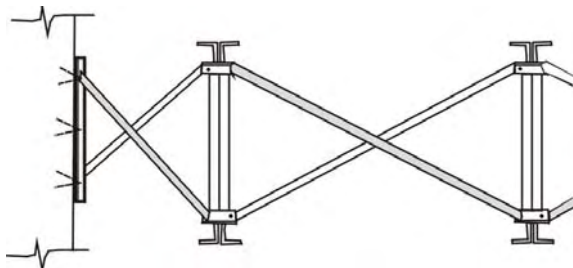

BRITISH THERMAL UNIT (BTU). A unit for measuring heat. A single unit represents the heat necessary to raise the temperature of one pound of water one degree Fahrenheit.

BROILER HOUSE. A structure used to house chickens to be sold as meat.

BUILDING ENVELOPE. The walls, roof, and floors which enclose a heated or cooled space.

BUILDING PAPER. Asphalt saturated felt paper sheathing for walls and roofs; used to stop drafts and insulate against dampness.

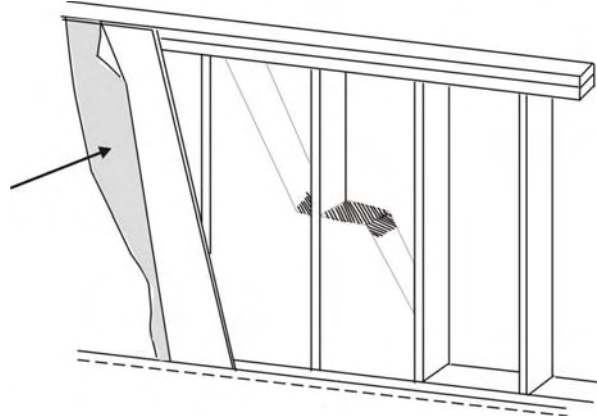

BUILDING SERVICE SYSTEMS. Those units or systems which provide plumbing, sewerage, heating, ventilating, air conditioning, lighting, power, vertical transport, fire protection, and special services, such as public address or oxygen, to a building.

BUILT-INS. Items like cabinets, counters, desks, benches, shelving, and equipment that are permanently attached to the building structure and could not be removed without leaving evidence of removal.

BUILT-UP ROOFING. Two or more layers of tarred felt, joined with bonding or sealing compound, and frequently mopped with hot asphalt between applications of felt.

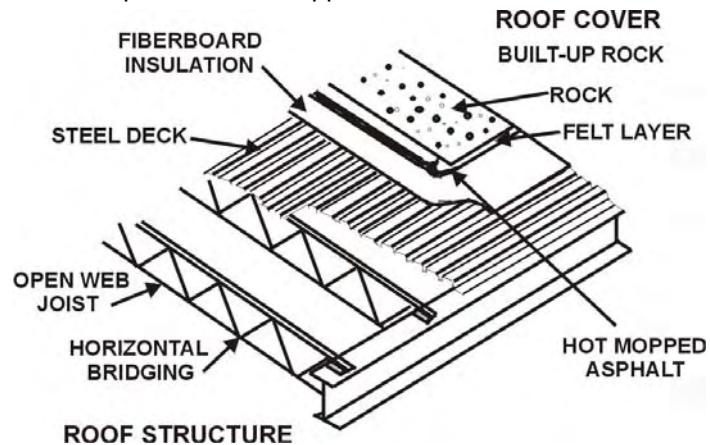

BULB TEE. A slender "T" shaped steel member used in poured gypsum roof decks to span between purlins to support gypsum planks over which the gypsum deck is poured. The "bulb" at the top of the stem is to give better bond to the gypsum.

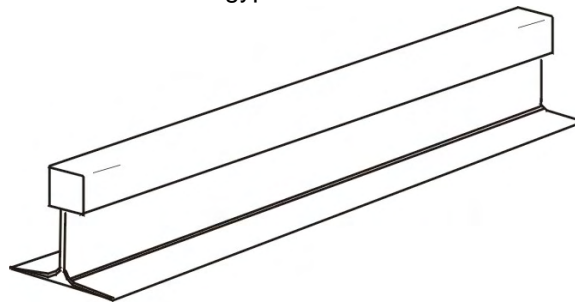

BULKHEAD. A retaining wall, or the wall beneath a display window.

BUTTRESS. An external structure, usually brick or stone, built against a wall to support or reinforce it.

BX. Wiring encased in a flexible metal tube.

-C-

CAISSON. A drilled, cylindrical foundation shaft used to transfer a load through soft strata or bedrock. The shaft is filled with concrete.

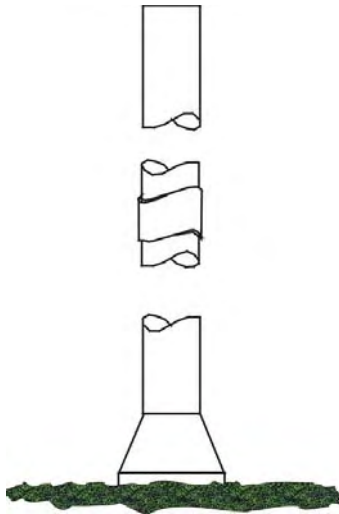

CAISSON FOUNDATION. A foundation system in which holes are drilled in the earth to bearing strata and then filled with concrete.

CANOPY. A roof, not covering a building, which extends over an exterior area such as a loading dock, building entrance, or window to protect against sun or rain.

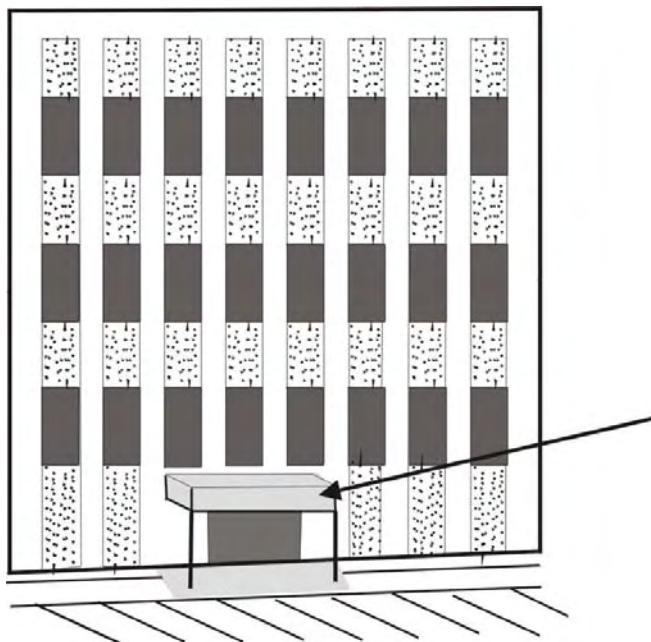

CANT STRIP. A wedge or triangular shaped piece, generally installed on flat roofs around the perimeter or at the junction of that roof and an adjoining wall to minimize potential leaks due to the roof cracking or breaking at the perimeter.

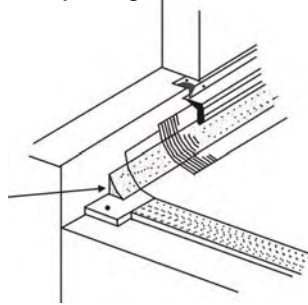

CANTILEVER. A structural member projecting horizontally well beyond its vertical support.

CARCASS, CARCASE. (1) A body or shell without adornment or life. (2) The structural framework of a building without walls, trim, carpentry, masonry, etc.

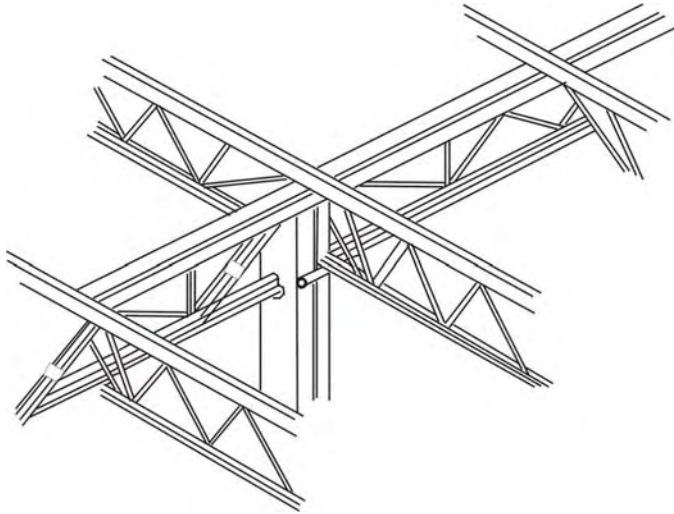

CARPORT. An open automobile shelter. May be only a roof and supports or may be enclosed on three sides with one completely open side.

CASEMENT WINDOW. A type of window having a sash with hinges on the side.

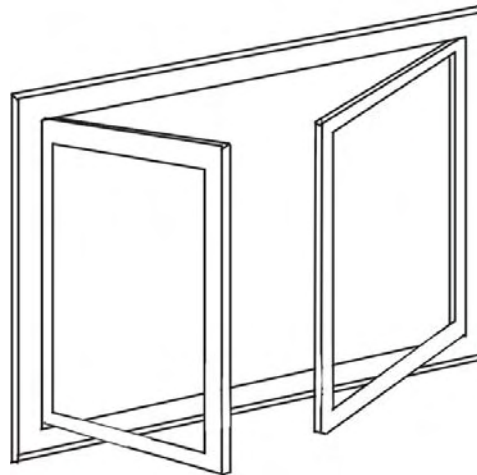

CASING. A pipe inserted in wells to prevent the sides from collapsing. It may also function to exclude undesirable elements, or prevent the escape of the contents. A piece of trim material around the sides and top of doors, windows, and other openings in a wall.

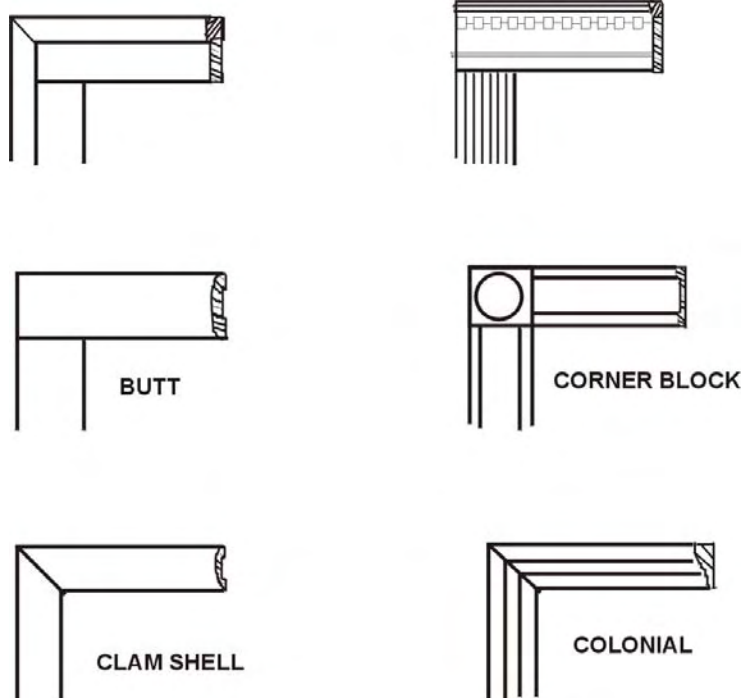

CAVITY WALL. An exterior masonry wall in which the inner and outer wythes are separated by an air space, but tied together with wires or metal stays.

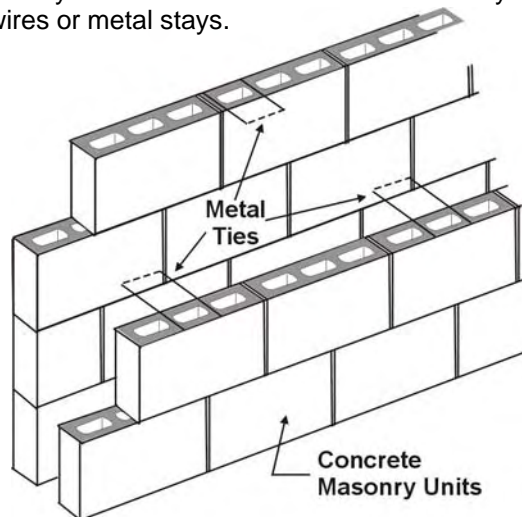

CEILING. The overhead inside lining or finish of a room or area. On the exterior, any overhanging surface viewed from below.

CEILING, CATHEDRAL. A pitched ceiling that parallels the roof in which ceiling material is fastened directly to rafters, eliminating the need for ceiling joists.

CEILING, SUSPENDED. A ceiling which is hung from the floor or roof structure above .

CEILING, VAULTED. A pitched ceiling that may have a different pitch than the roof, facilitating the need for joists.

CELLULAR DECK. A structural floor system, consisting of two layers of sheet metal shaped to form cells and welded together. Cells serve as raceways for electrical conduit or other utilities.

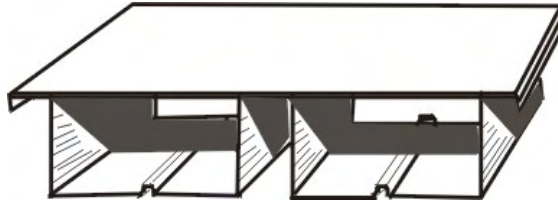

CHIMNEY. A masonry structure containing a vertical flue.

CHIPBOARD. A flat panel manufactured to various thicknesses by bonding flakes of wood with a binder.

CLAPBOARD. Siding board of varying widths, with the lower edge thicker than the upper edge that is covered by the lower edge of the board above.

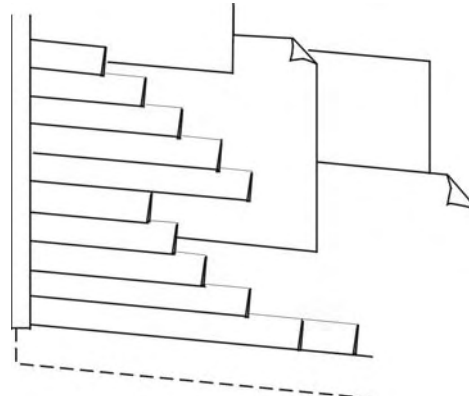

CLAY TILE. A fired earthenware tile used on roofs. Also called quarry tile when used for flooring.

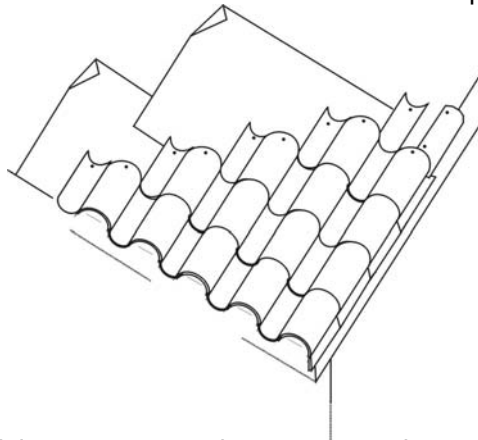

CLEAN ROOM. A special purpose room that meets requirements for the absence of lint, dust, or other particulate matter. In a clean room, the filter systems are high efficiency and the air exchange is one-directional laminar flow.

CLEAR SPAN. A term used to designate a building or an area within a building, free of columns.

CLERESTORY WINDOW. A window or series of windows in a wall above the primary roofline designed to provide additional lighting and ventilation for the central part of a building.

COLD AIR RETURN. In a heating system, the return air duct that transports cool air back to the system to be reheated.

COLLAR BEAM/TIE. The horizontal board that joins the approximate midpoints of two opposite rafters in order to increase rigidity and prevent wood roof framing from shifting.

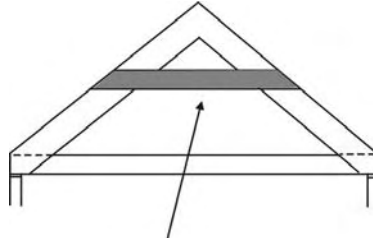

COLUMN. A vertical structural member supporting horizontal members; e.g., beams and girders designed to transmit the load to the bearing material at the base of the column.

COLUMN FOOTING. The foundation under a column that spreads the loads out to an area large enough so that the bearing capacity of the soil is not exceeded and differential settling does not occur.

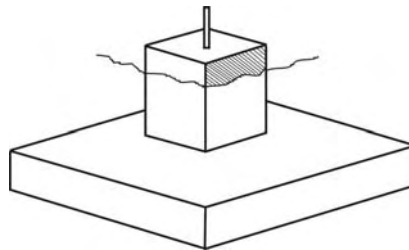

COMMON BRICK. Local inexpensive clay brick, no uniform face or precision mold.

COMMON WALL. The wall between two distinct sections of a building.

COMPONENT. The term used to designate a combination of construction elements, such as the complete exterior walls, framing, floor, roof construction, interior finish, and building service systems.

COMPOSITION SHINGLE. A roofing shingle made of either felt saturated with asphalt and surfaced with mineral granules or inorganic fiberglass saturated with asphalt and surfaced with ceramic granules.

COMPUTER FLOOR. A raised floor designed to accommodate the substantial wiring required by computers and electronic equipment. See also elevated floor.

CONCRETE. A hard, stone-like material made by mixing sand and aggregate such as crushed stone or gravel, cement, and water, and allowing the mixture to harden.

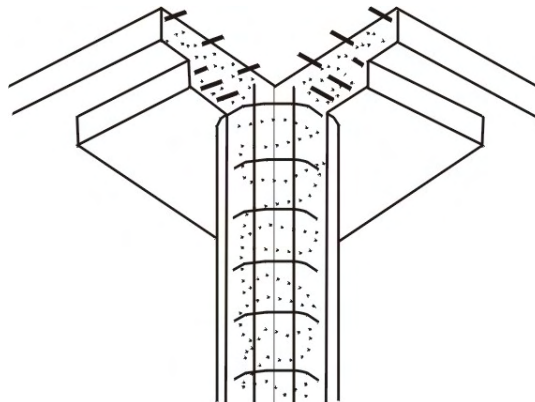

CONCRETE BLOCK. Concrete formed into the shape of a block and allowed to set until it hardens. Used as a masonry unit.

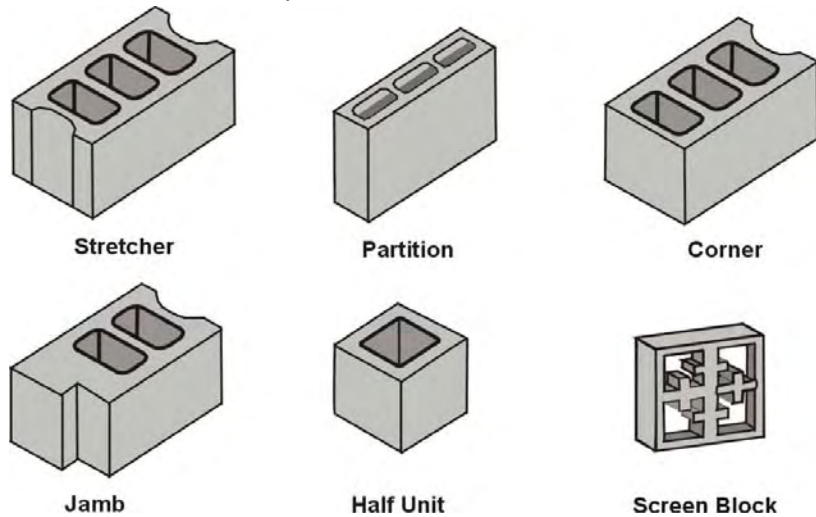

CONDUIT. Channel or tube to convey water or other fluid, such as pipe, canal, aqueduct, flume; protective pipe or tube for electric wires or cables .

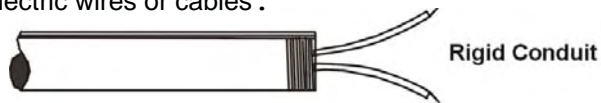

CONSTRUCTION COST INDICATOR (CCI). Building construction divided into five basic groups (A, B, C, D, and S) by type of framing, exterior walls, floors, roof structure, and fireproofing.

CONTINUOUS FOOTING. A concrete footing supporting a wall or two or more columns. The footing may vary in depth and width.

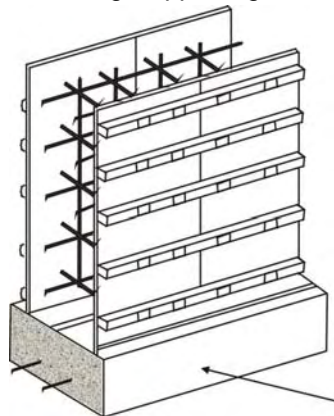

CONTINUOUS WINDOWS. Windows designed as sawtooth or monitor roofs of industrial buildings that are generally top-hinged and open mechanically.

COOLING TOWER. An outdoor structure, frequently placed on roofs, over which warm water is circulated to cool it by evaporation and exposure to the air.

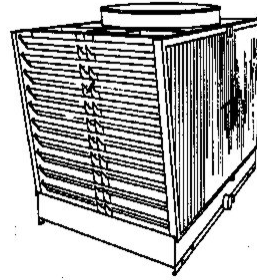

COPING. The top covering or capping of a wall.

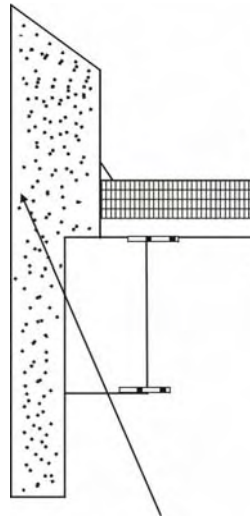

CORBEL. Supporting bracket of stone, brick, or wood projecting from side of wall.

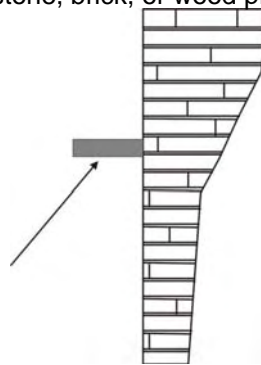

CORNICE. (1) An ornamental molding of wood or plaster that circles a room just below the ceiling. (2) An ornamental topping that crowns the structure it is on. (3) Exterior ornamental trim at the meeting of the roof and wall.

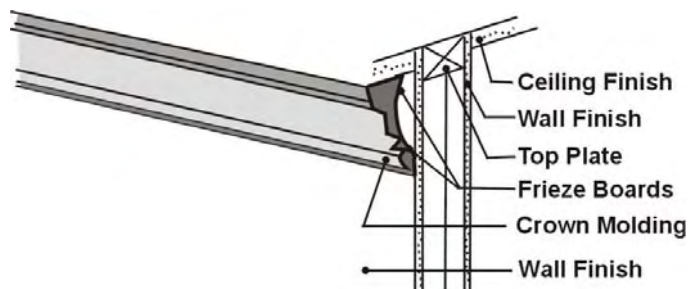

COURSE. A continuous horizontal layer of structural units such as brick, stone, slate, or shingle.

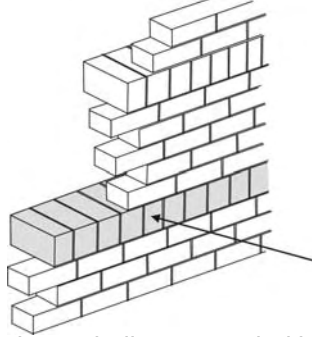

COURT. An uncovered area partly or wholly surrounded by a building or walls.

CRANE. A device for lifting and moving heavy weights. There are two types of traveling cranes: (1) the overhead crane, a bridge-like structure which moves on parallel tracks above and operated inside work areas; and, (2) the gantry crane, which supports the bridge on its own legs that move on fixed tracks and usually operates outdoors at ground level. The one-leg gantry combines features of both. The jib crane has an arm guyed at a fixed angle to the head of a rotating mast. The boom of a derrick is also considered a crane.

CRAWL SPACE. An unfinished, accessible space below the first floor, generally less than full-story height.

CURRENT REPLACEMENT COST. The total cost estimate based on the current cost to construct a building of like utility using modern design, materials, and workmanship. The estimate is then adjusted for time and location.

CUPOLA. A small square or rectangular structure located along the roof ridge used for ventilation and/or ornamentation.

CURB. Stone or concrete edging of sidewalk or paved street; raised edge of floor or wall opening.

CURTAIN WALL. An exterior wall which encloses but does not support the structural frame of a building.

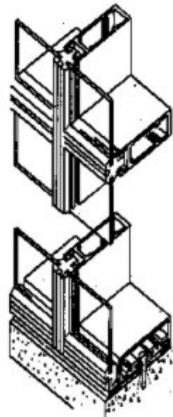

-D-

DAMAGED PROPERTY. An improvement that was damaged for the current assessment year. Indicated by a "2" code; accompanies an entry in the percent complete field on the data collection form.

DESTROYED PROPERTY. An improvement that was destroyed for the current assessment year. Indicated by a "3" code; accompanies an entry in the percent complete field on the data collection form.

DEAD LOAD. The weight of the structure itself plus any permanent fixed loads.

DECK. (1) An uncovered wood platform usually attached to the structure to provide additional outdoor living area. (2) The flooring of a building.

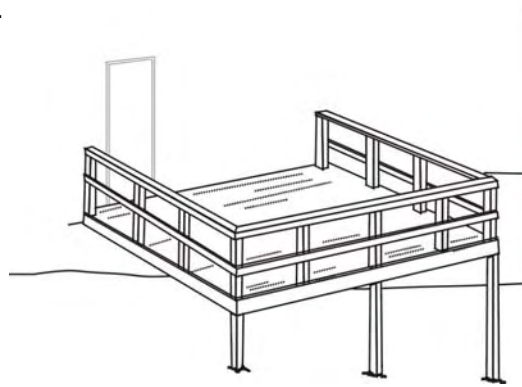

(3) The structural systems to which a roof covering is applied.

DECKING. Light-gauge corrugated metal sheets used in constructing roofs or floors; heavy planking used in roofs or floors.

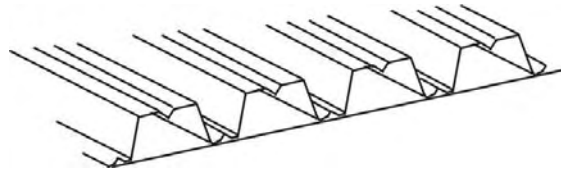

DEGRADATION. Deterioration of a painted surface by heat, light, moisture, or other elements.

DEMAND. The electric load integrated over a specific interval of time and usually expressed in watts or kilowatts.

DEMOLITION. The intentional destruction of all or part of a structure.

DEPRECIATION. Depreciation is loss in value due to any cause. It is the difference between reproduction or replacement cost new of an improvement and its market value as of the date of valuation. Depreciation is divided into three general categories: physical depreciation, and functional or economic obsolescence.

DESIGNER PLANS. House plans furnished by professional designers.

DIRECT EXPANSION MILK COOLER. Refrigerated milk cooler storage tanks.

DIRECT FIRED AIR HEATER. An air heating system in which the heat of combustion is applied directly to the intake air with no heat exchanger. For example, a space heater.

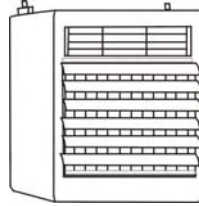

DOCK BUMPER. A recoiling or resilient device attached to a dock and used to absorb the impact of a truck.

DOCK LEVELER. Typically, an adjustable mechanized platform built into the edge of a loading dock. The platform can be raised, lowered, or tilted to accommodate the handling of goods or material to or from trucks.

DOME. A roof shaped like a hemisphere or inverted bowl, so constructed as to exert equal, oblique thrust stresses in all directions.

DORMER. A window set upright in a sloping or pitched roof; also, the roofed structure in which this window is set.



DOUBLE GLAZING. Fenestration with two panes of glass with an air space between for increased thermal and sound insulation.

DOUBLE-HUNG WINDOW. A type of window containing two movable sash stations which slide open vertically.

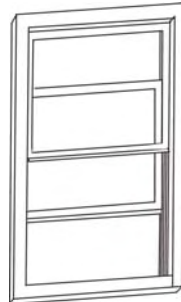

DOUBLE WALL. An exterior frame wall with siding, sheathing, and interior lining.

DOWNSPOUT. Pipe to conduct rainwater from roof gutters to ground or storm sewer system.

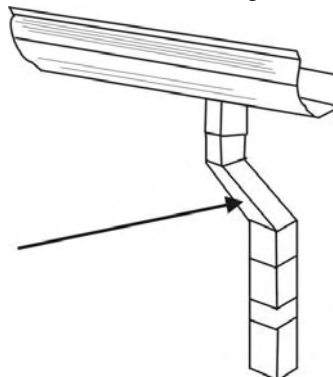

DRAIN TILE. Burnt clay tile pipe, rendered impervious to water by glazing and laid with loose, unsealed joints.

DRESSED AND MATCHED. Boards that are finished, or dressed, on one or two sides and tongue-and-grooved on the edges.

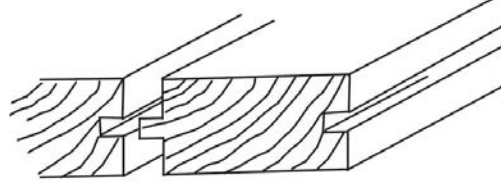

DRILLED CAISSON. A hole drilled into the ground, then filled with concrete. Depending on soil conditions, a pipe lining may be included.

DROP PANEL. In reinforced concrete slab construction, a thickened portion of the ceiling around a column head.

DRYWALL CONSTRUCTION. Any type of interior wall construction not using plaster as a finish material; e.g., wood paneling, plywood, plasterboard, or other type of wallboard.

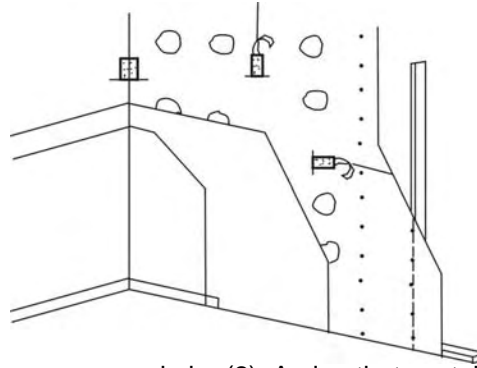

DUCT. (1) A pipe to convey warm or cool air. (2) A pipe that contains electrical wires or cables.

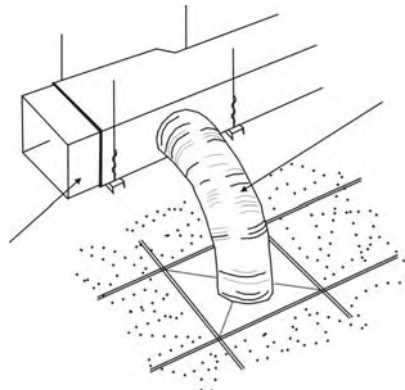

DUMBWAITER. A small utility elevator, used to convey articles, and not people, between floors.

DUPLEX. House containing two separate dwelling units.



DWELLING. Building designed for or used as living quarters by one or more families.

-E-

EAVES. The lower or outer edge of a roof which overhangs the sidewall of a building.



ECONOMIC LIFE. The estimated period during which a property is expected to be useful and profitable; usually shorter than physical life.

ECONOMIC OBSOLESCENCE. A loss in value caused by unfavorable economic influence occurring outside a property; e.g., development of a rubbish disposal area near a residence.

EFFECTIVE AGE. The age of a building indicated by its condition and architectural design; may be less than the actual age if the building is modernized, more if it is not in repair.

EIFS. Exterior insulation and finish system; see synthetic plaster on rigid insulation.

ELASTOMERIC ROOFING. Single sheet (ply) of rubber-like, layered membrane consisting of several combinations of plastics and synthetic rubber stretched into place as a roof cover. It may be loosely laid, ballasted, mechanically fastened, or fully adhered. Also used to describe a single component liquid or spray applied to the roof surface to yield elastomeric films for high-strength waterproof membranes.

ELECTRIC BASEBOARD HEATER. A heating system with electric heating elements installed in longitudinal panels, usually along baseboards of the exterior walls.

ELEVATED FLOOR. Any floor system not supported by the subgrade.

ELEVATED SLAB. Any floor or roof slab supported by structural members.

ELEVATION. A view or drawing of the interior or exterior of a structure as if projected onto a vertical plane.

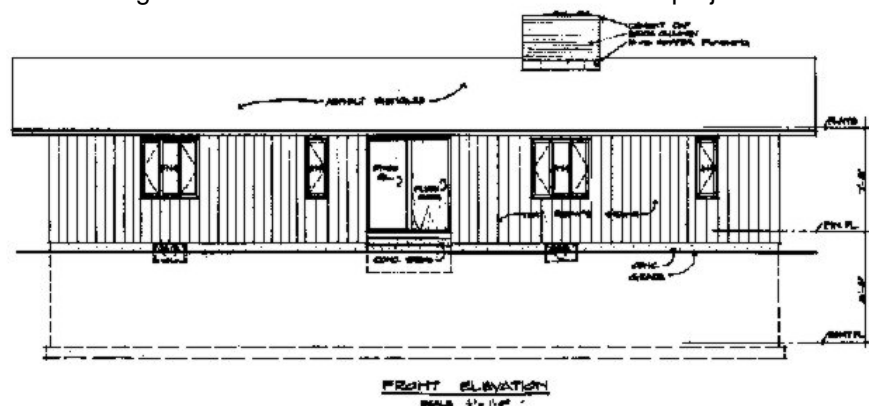

ELEVATOR. A “car” or platform that moves within a shaft or guides and is used for the vertical hoisting and/or lowering of people or material between two or more floors of a structure. An elevator is usually electrically powered, although some short-distance elevators (serving fewer than six or seven floors) are powered hydraulically.

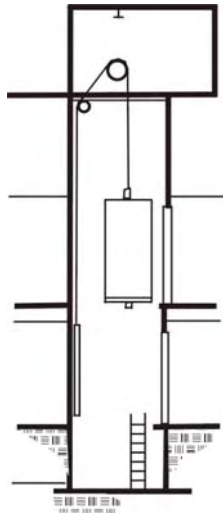

ESCALATOR. Power-moved stairway.

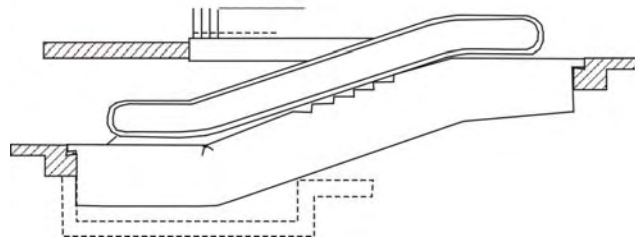

EVAPORATIVE COOLING. Cooling achieved by the evaporation of water in air, thus increasing humidity and decreasing dry-bulb temperature.

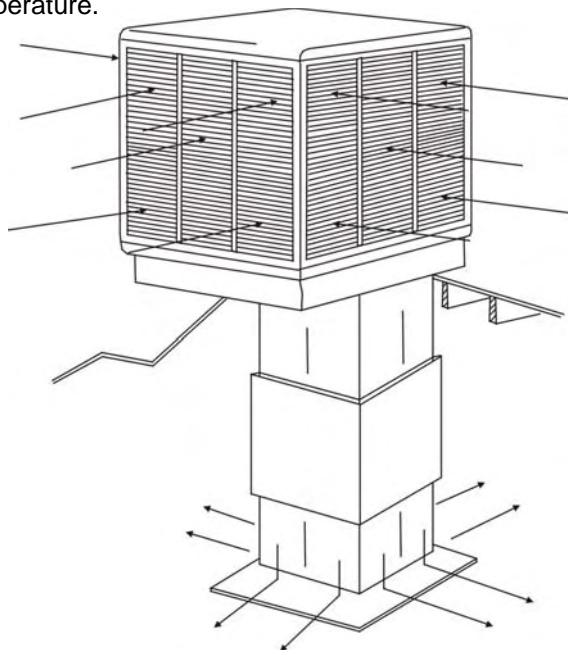

EXCAVATION. A hole or hollow dug in the earth.

EXTENSION. A one-story structure on a building; built during original construction with no wall partitions to separate it from the other building.

-F-

FAÇADE. The front of a building, especially one that is imposing or decorative.

FACE BRICK, FACING BRICK. Generally, a hard burned brick of smooth or rough texture face, of selected color and size, used to finish the exterior walls of a building.

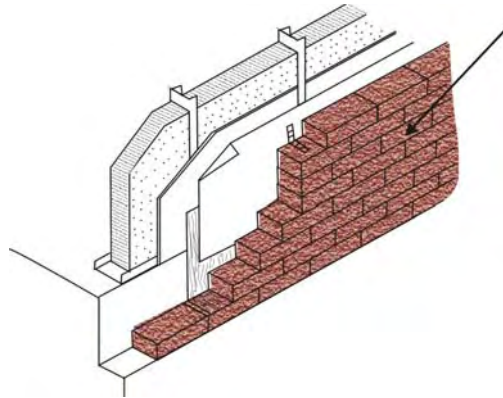

FAIR MARKET VALUE. By statutory definition, the same meaning as market value: “. . . the most probable price expressed in terms of money that a property would bring if exposed for sale in the open market in an arm’s-length transaction between a willing seller and a willing buyer, both of whom are knowledgeable concerning all the uses to which it is adapted and for which it is capable of being used.” (IAAO [Property Assessment Valuation](#) textbook)

FARROWING PEN. An enclosure where sows can give birth and nurse young.



FASCIA. (1) Any relatively broad, flat, vertical surface like that on the outside of a cornice. (2) A finishing board used to conceal rafter boards and applied horizontally around the perimeter of the rafters.



FENESTRATION. The design and disposition or arrangement of windows or other openings in a building wall.

FIBERBOARD. A prefabricated building board of wood or other plant fibers compressed and bonded into a sheet.

FIBERGLASS. Fine-spun filaments of glass made into yarn, used in woolly masses as insulation. May be added to gypsum or concrete products to increase tensile strength.

FILL. (1) Soil or other material used to raise the grade of a site. (2) A subfloor leveling material.

FILLER DISTRIBUTOR. Automatic silo loading, leveling, and compacting mechanism which packs layers of silage uniformly from silo center to wall.

FINISH FLOOR. The flooring material that is installed over concrete slab or wood subfloor. May be sheet vinyl, terrazzo, tile, carpeting, or other floor covering material.

FIRE DOOR. Door consisting of a core and external surfaces especially constructed to prevent the spread of fire. A fire door will frequently include a self-closing system in the event of a fire.

FIRE RESISTIVE CONSTRUCTION. A building where the bearing walls or bearing portion of walls, structural floors, roof and their supports are of materials with a fire resistance rating of not less than two hours.

FIRE WALL. A wall with qualities of fire-resistance and structural stability which subdivides a building into areas to control the spread of fire.

FIREPROOFING. The use of incombustible materials to protect structural components of a building so it can withstand a complete burnout of contents without losing structural integrity.



FLAG STONE. Flat stone, one to four inches thick, for rustic walks, steps, floors.



FLASHING. A thin, impervious sheet of material placed in construction to prevent water penetration or direct the flow of water. Flashing is used especially at roof hips and valleys, roof penetrations, joints between a roof and a vertical wall, and in masonry walls to direct the flow of water and moisture.

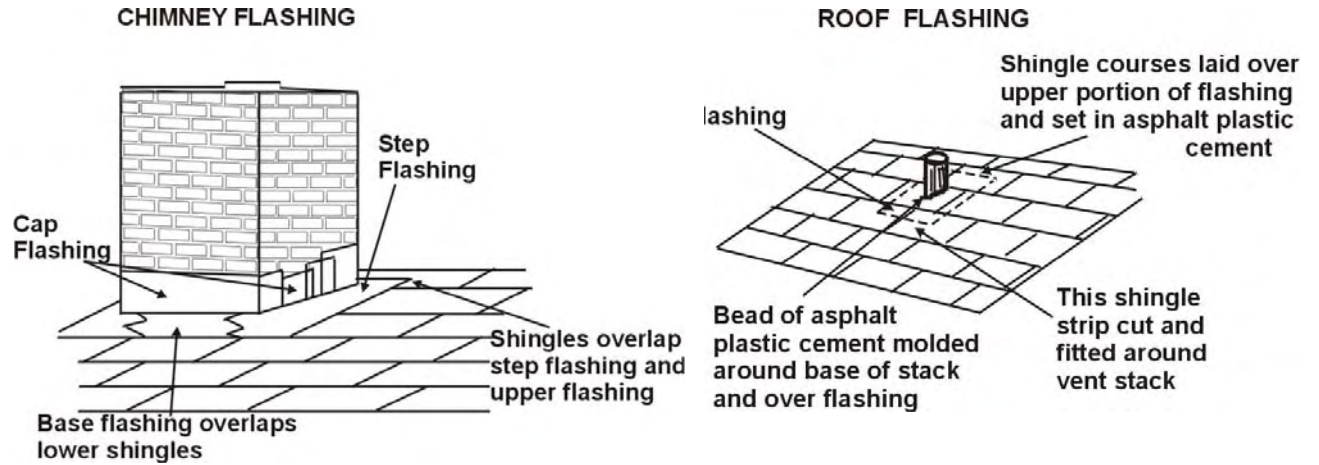

FLAT PLATE DECK. (1) An elevated concrete slab, usually supported by columns, which is similar to a two-day (beamed) slab but does not have beams between the columns, (2) Slabs reinforced to span like a flat plate between supporting columns.

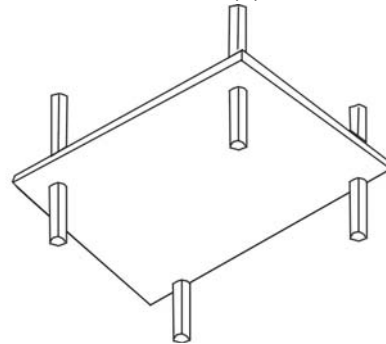

FLAT ROOF. Roof with pitch or slope with less than 1'0" of rise for each 12'0" of run.

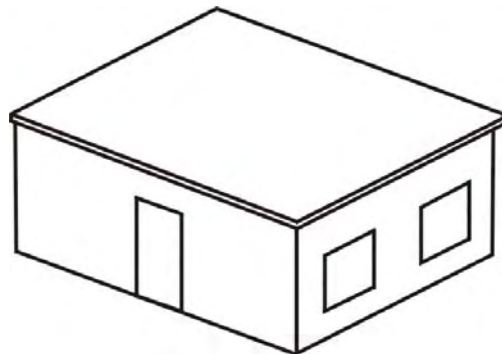

FLOAT FINISH. Finishing the surface of newly poured concrete by a continuous spreading of the material with a flat board.



FLOATING OR MAT FOUNDATION. A heavily reinforced concrete slab, usually four to eight feet thick, covering the entire foundation area of a structure.

FLOOR AREA. Total horizontal surface of a specific floor (or the total area of all floors in a multi-story building), computed from the outside building dimensions of each floor. Balcony and mezzanine floor areas are computed separately and added to the total floor area.

FLOOR FINISH. Top, or wearing, floor surface made of hardwood, linoleum, terrazzo, tile, or other finish materials.

FLOOR STRUCTURE. Maintains the structural strength needed to support both the live and dead load requirements.

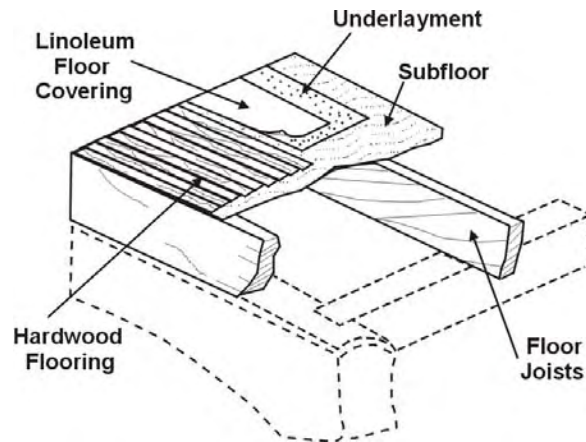

FLUE. The duct or space within a chimney through which combustible gases and smoke are allowed to escape.

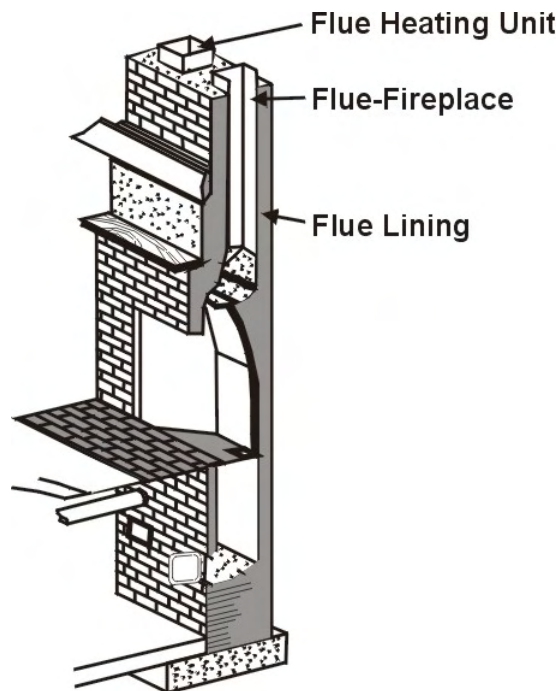

FLUORESCENT LAMP. A low-pressure mercury electric-discharge lamp in which a phosphor coating on the inside of the tube transforms some of the ultraviolet energy generated by the discharge into visible light.

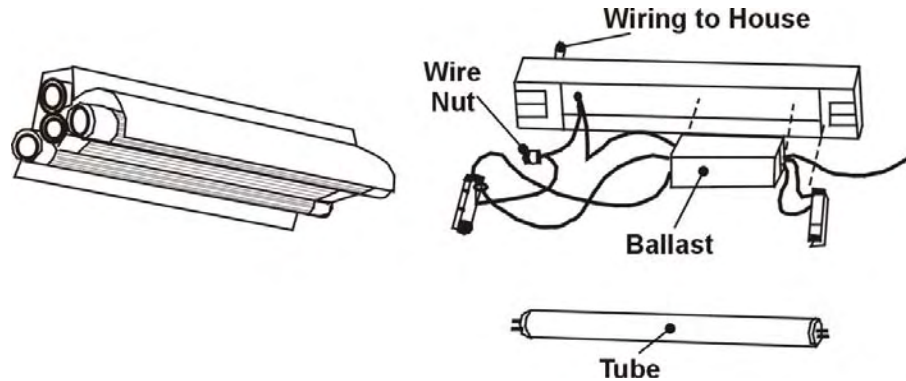

FOLDED PLATE DECK. A pleated type of roof structure, usually of concrete, consisting of inclined intersecting planes and used to span large areas.

FOOTING. The projecting course at the base of a foundation wall which ties the foundation into the ground to prevent lateral shifting and setting. Distributes the superstructure load over a greater area.

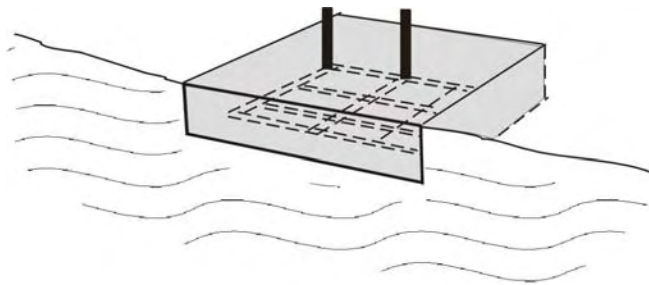

FORCED AIR HEATING. A warm air heating system in which circulation of air is effected by a motor-driven fan. Such a system includes air-cleaning devices and the ductwork. Costs include simple single-zoned and multi-zoned ducted systems.

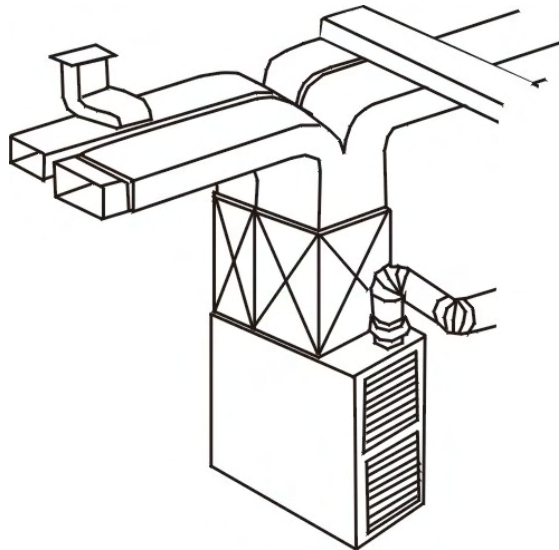

FORMICA. Trademark of hard plastic sheeting used for table, wall coverings.

FORMS. Temporary panels that contain the shape of poured concrete foundation until hard; usually of wood, plywood, or metal.

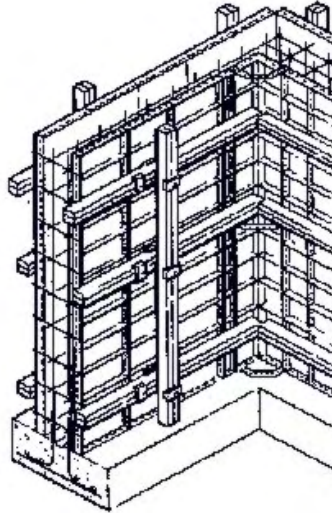

FOUNDATION. (1) The supporting part of a wall or building. (2) The substructure below the ground or basement floor on which the superstructure rests.

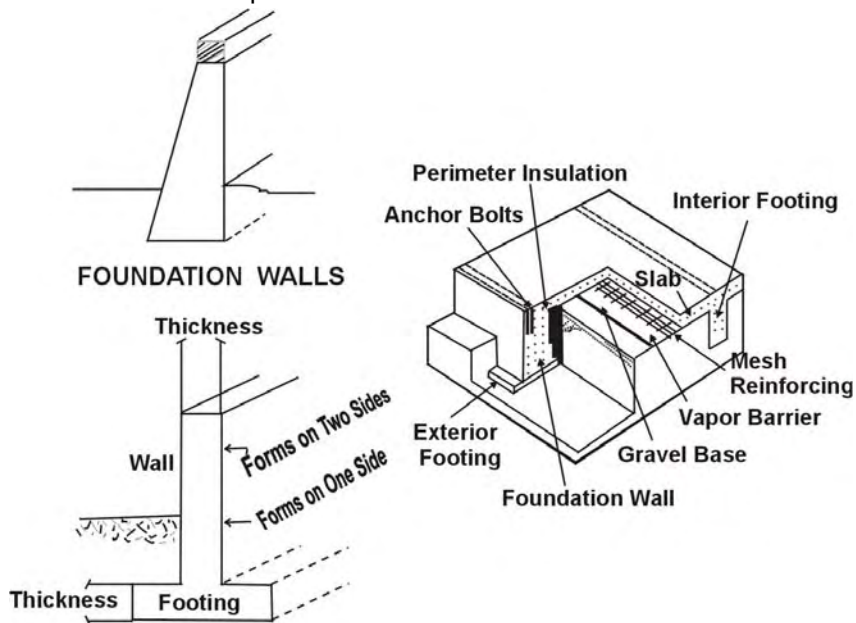

FOYER. The lobby of a theater or hotel; the entrance hall of a house.

FRAME CONSTRUCTION. A building where the exterior walls, bearing walls and partitions, and the structural floors and roof and their supports are wholly or partly of wood or other combustible material. This includes buildings in which the combustible materials are combined with other materials to form composite components such as wood stud walls with brick or stone veneer, stucco, or metal siding.

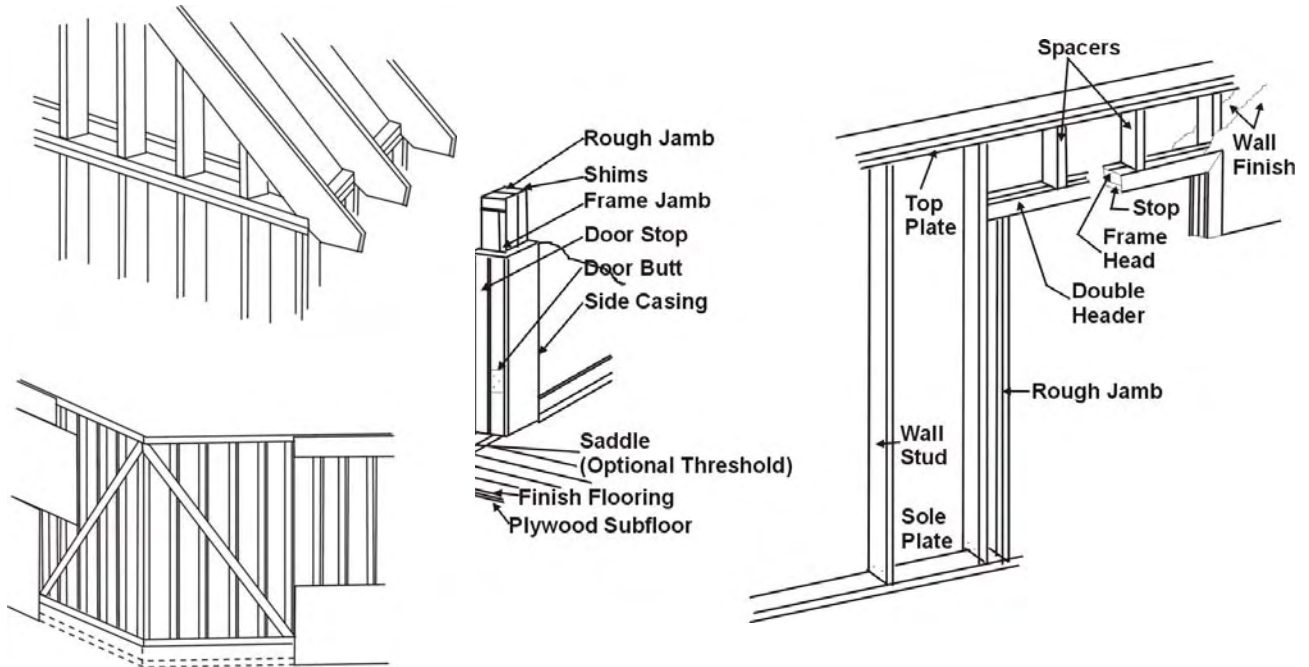

FREE-STALL. Individual stall where cow may enter, lie down, or leave at its will.

FULL CASH VALUE. Full cash value for property tax purposes means the value determined as prescribed by statute. If no statutory method is prescribed, full cash value is synonymous with market value which means the estimate of value that is derived annually by using standard appraisal methods and techniques.

FUNCTIONAL OBSOLESCENCE. A loss in value occurring within a structure caused by changes in design, overcapacity, or inadequacy; e.g., high ceilings, old-style fixtures or cabinets, poor floor plan.

FURRING. The strips of wood or metal applied to a wall or other surface to make it level, to form an air space, or to provide fastening surface for a finish covering.

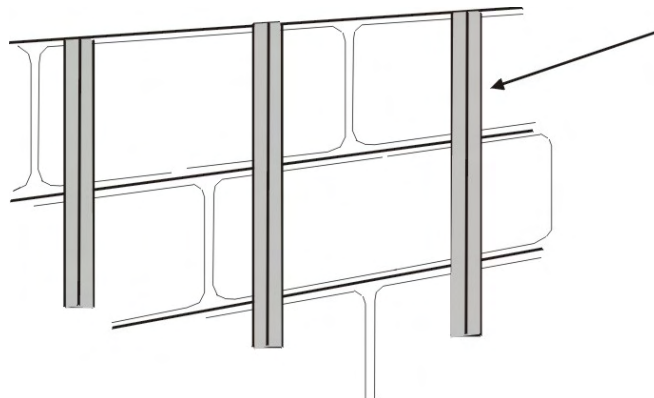

-G-

GABLE. The wall at the end of a building above the eaves and between the slopes of a rigid roof.

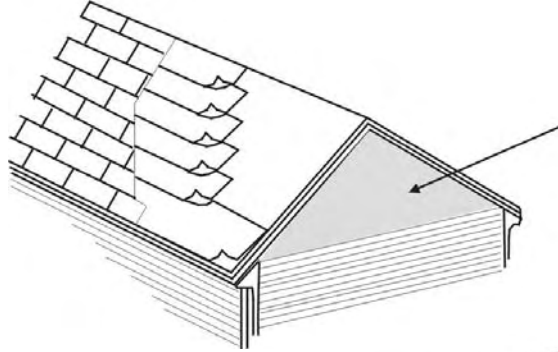

GABLE ROOF. A roof forming an inverted V.

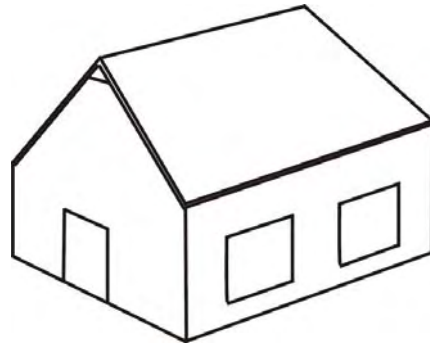

GAMBREL ROOF. A ridged roof, with sides having two pitches or slopes.

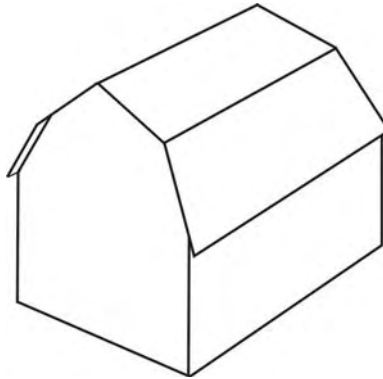

GARAGE. Structure to house automobiles.



Attached

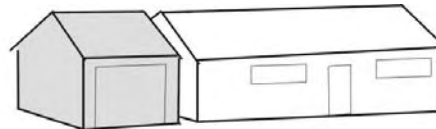

Detached



Built-in

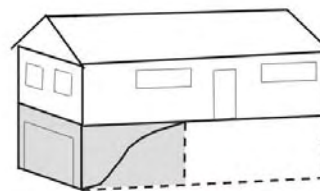

Basement

GIRDER. A horizontal structural member that supports loads from smaller beams and joists and transmits them to columns or foundations.

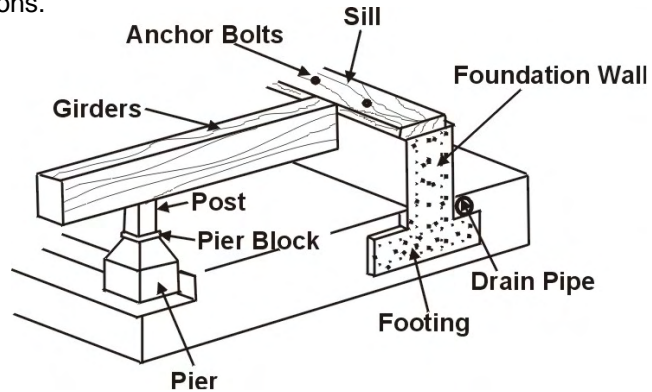

GIRT. A secondary horizontal framing member extending between columns or studs to stiffen the framing system; also to provide support for the siding or sheathing.

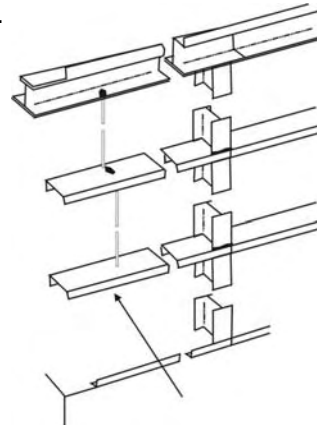

GLAZING. Fixing glass in an opening; the glass surface of an opening which has been glazed.

GLULAM. A trade name often used to describe all glued, laminated wood structural members.

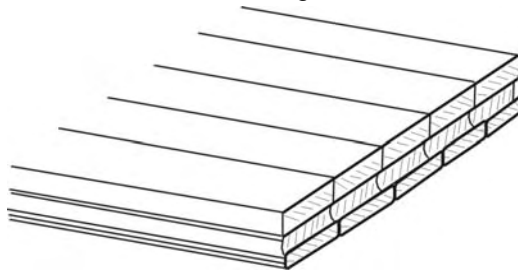

GRADE. The plane of the natural or finished surface of the ground.

GRADE BEAM. A horizontal load-bearing foundation member. End supported like a standard beam, not ground supported like the foundation wall.

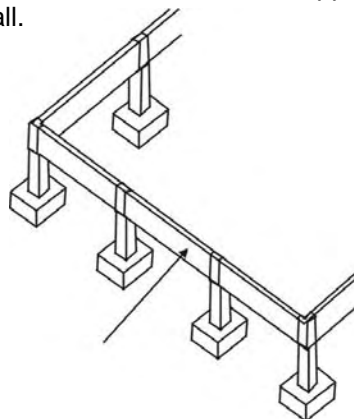

GRAVEL STOP. Ridge on perimeter of roof to retain gravel on a built-up roof system.

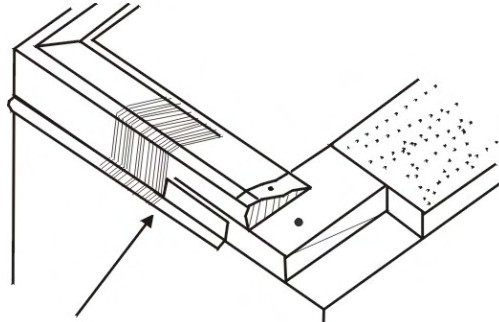

GRAVITY HEATING. A warm air system usually located in a basement, which operates on the principle of warm air rising through ducts to the upper levels. Since it does not contain a fan, as does the conventional forced-air furnace, a large burner surface as well as larger ducts is used.

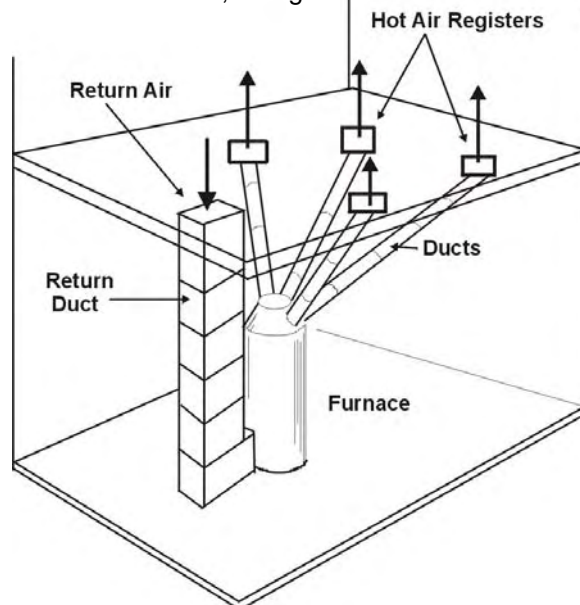

GROSS AREA. The total enclosed floor area of a building measured from the outside surface of the exterior walls.

GROUND AREA. The area computed from the exterior dimensions of the ground area.

GROUND FLOOR. The floor of a building which is approximately level with the ground.

GROUND FLOOR AREA. Area computed using the exterior dimensions of the ground floor, or that floor which is approximately level with the ground.

GROUT. Thin mortar mixture to fill joints or cavities of mason work.

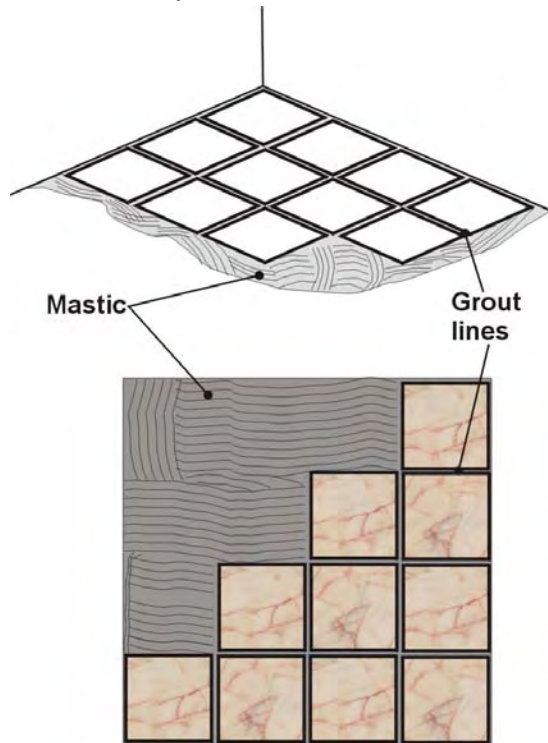

GUARDRAIL. A horizontal rail of metal, wood, or cable fastened to intermittent uprights of metal, wood, or concrete around the edges of platforms.

GUNITE. Pneumatically placed concrete, sometimes refers to pneumatically placed plaster. Also called shotcrete.

GUSSET. A flat surface of plywood or metal used to reinforce a joint of a truss.

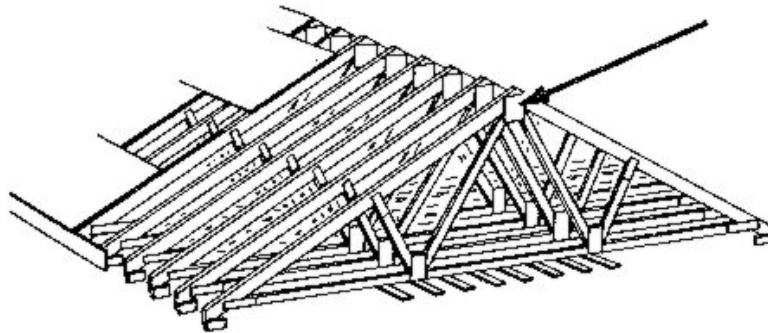

GUTTER. A horizontal rain trough at the edge of a roof.

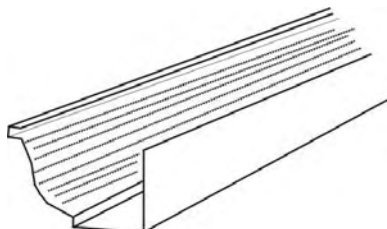

GUY. A cable or rope anchored in the ground at one end and supporting or stabilizing an object at the other end.

GYP SUM WALLBOARD. A prefabricated sheet used in drywall construction as a substitute for plaster. May be made of gypsum covered with paper that can be painted, textured, or wallpapered.

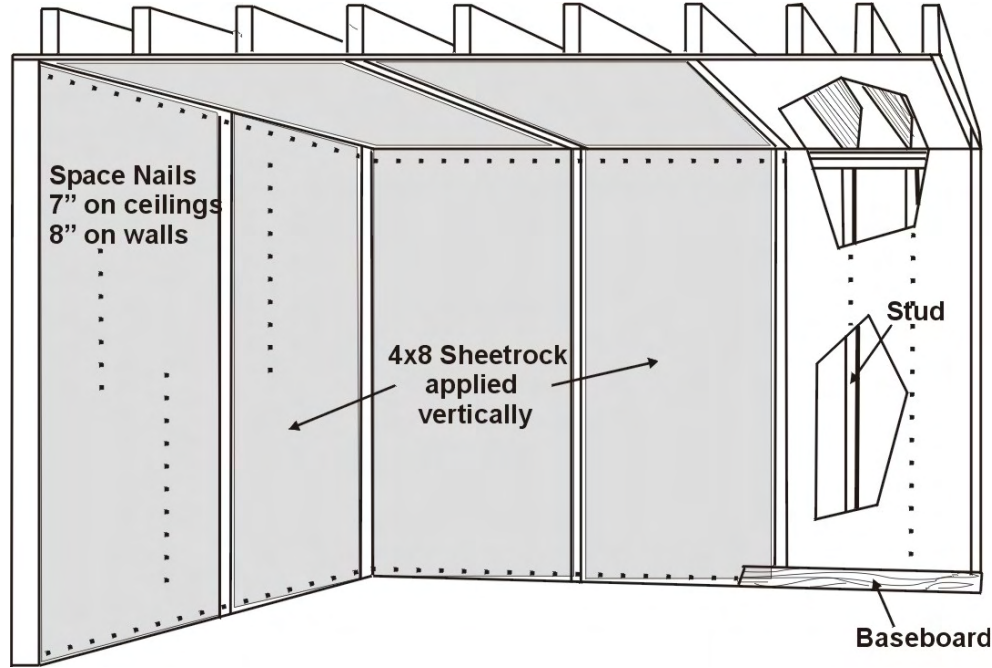

-H-

HALL. (1) A room at the entrance of a building or a passage providing access to various parts of a building. (2) A large room used for public gatherings.

HARDBOARD. Boards formed by combining shredded wood chips and glue with pressure.

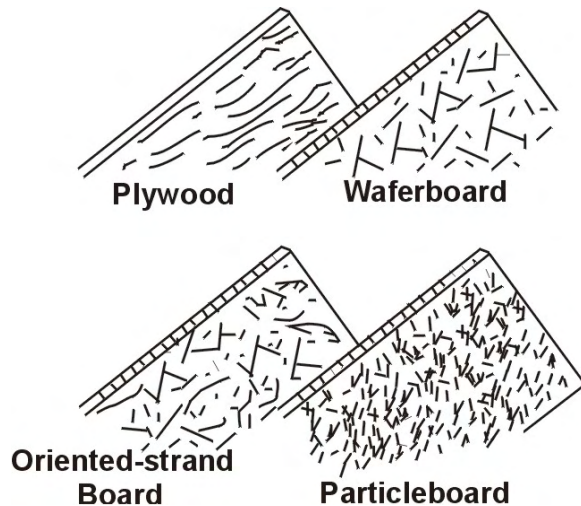

HARDWOOD. Wood from broad-leaved deciduous trees. Examples are oak and maple.

HEADER. (1) A rectangular masonry unit laid across the thickness of a wall so as to expose its end. (2) A lintel. (3) A member extending horizontally between two joints to support tailpieces. (4) Structural members used to span an opening above doors, windows, etc.



HEARTH. The floor of a fireplace.

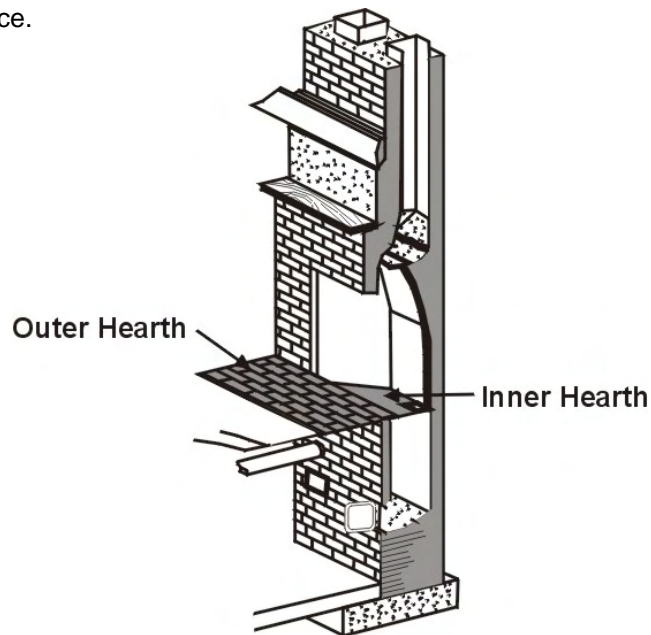

HEAT ABSORBING GLASS. Slightly blue-green tinted plate glass or float glass designed with the capacity to absorb 40% of the infrared solar rays and about 25% of the visible rays that pass through it. Cracking from uneven heating can occur if the glass is not exposed uniformly to sunlight.

HEATER. A general term including ceiling-hung heating units, stoves, appliances, and other heat-producing units.

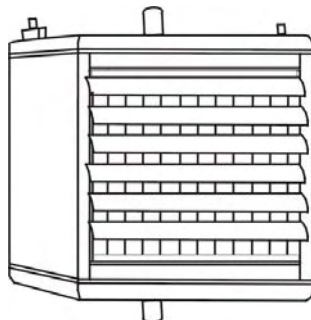

HEATING AND COOLING. A combined heating and cooling system which is broken into three general categories of descending cost ranges as described below.

HEAT EXCHANGER. Cylinder with coils in it; used to transfer heat from one gas or liquid to another.

HEAT PUMP. An all-season system that provides either heating or cooling as required.

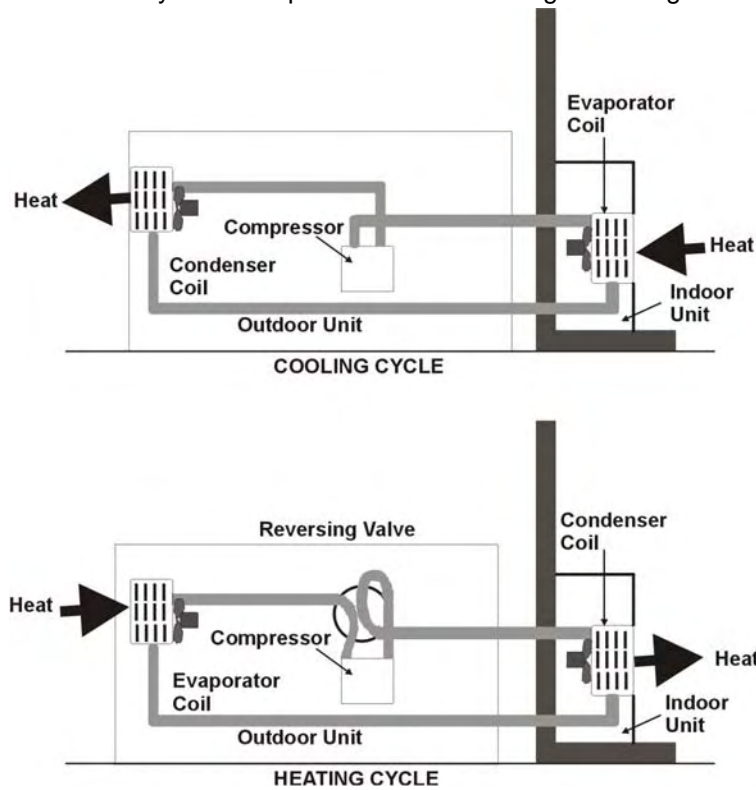

HERRINGBONE STALLS. Stalls set at an angle to the milking parlor walkway and operator working pit.

HIGH INTENSITY DISCHARGE LAMP. A mercury, high pressure sodium, or other electric discharge lamp requiring a ballast for starting and for controlling the arc, and in which light is produced by passing an electric current through a contained gas or vapor.

HIGH RISE. (1) A building having many stories, usually serviced by elevators. (2) A building with upper floors higher than fire department aerial ladders, usually 10 or more stories.



HIP RAFTER. Beam under hip of roof to receive jack rafters or purlins.

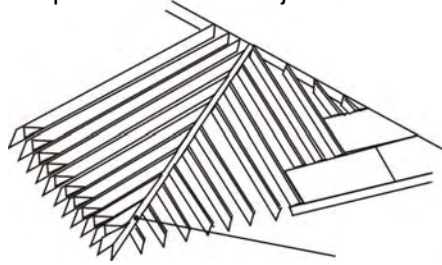

HIP ROOF. A pitched roof having sloping ends rather than gable ends.

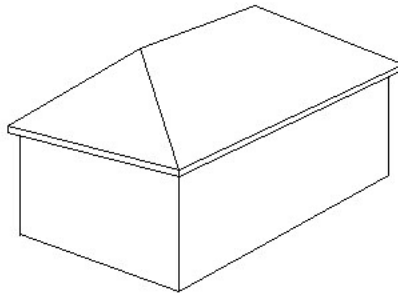

HOLLOW-CORE DOOR. A door with plywood or hardwood faces over a frame, with a hollow or honeycombed interior.

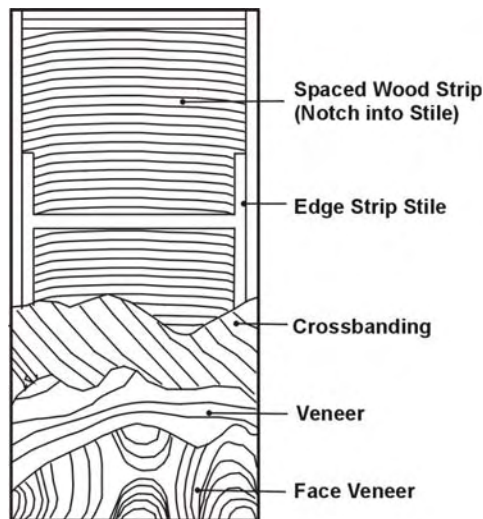

HOT AIR SYSTEM. Heating system in which air is heated by passing it over a combustion chamber. The air moves to living space through a single register or a series of ducts, circulated by natural convection (gravity system) or by a fan or blower in the ductwork (forced system).

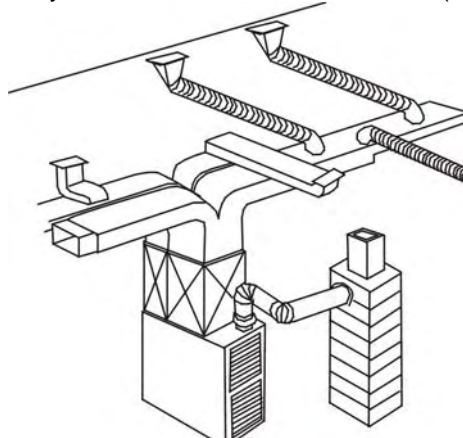

HOT WATER HEATING. The circulation of hot water from a boiler through a system of pipes and radiators or convectors, by either gravity or a circulating pump, allowing the heat to radiate into the room.

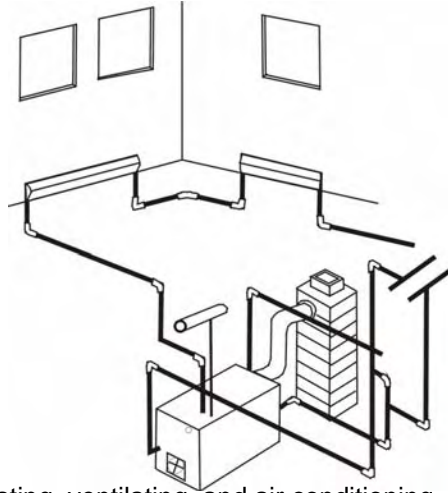

HVAC. An abbreviation for heating, ventilating, and air conditioning .

HYDRONIC HEATING. Hot water heating system.



I-BEAM. A structural member of rolled steel whose cross section resembles the capital letter "I".

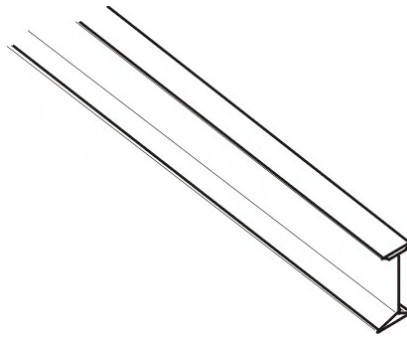

INCANDESCENT LAMP. A lamp in which electricity heats a tungsten filament to incandescence.

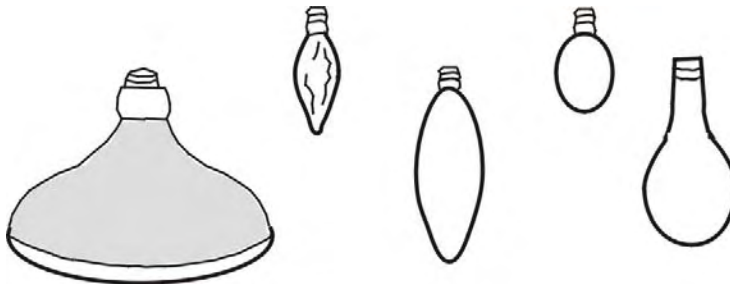

INSULATING BOARD OF FIBERBOARD. A building board made of compressed plant fibers such as wood, cane, or cornstalks; usually formed by a felting process, dried and pressed to specified thickness.

INSULATION. Any material used to reduce the transfer of heat, cold, or sound.

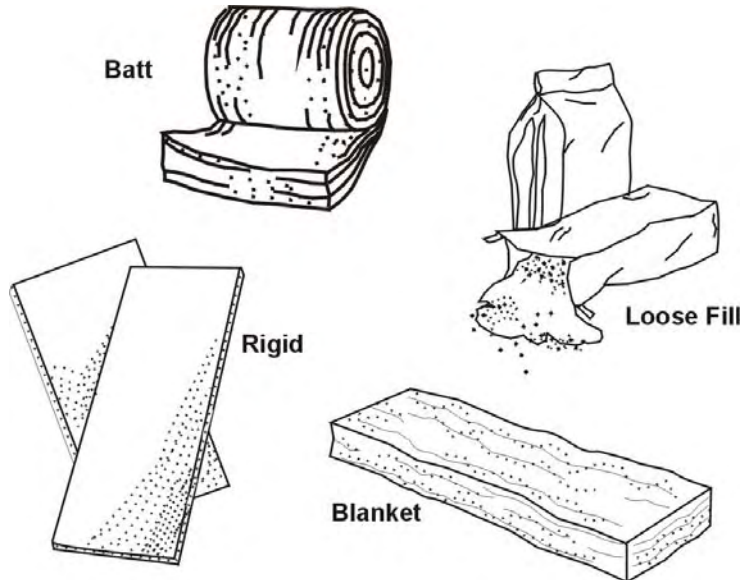

INTERSTITIAL SPACE. The walk-on platform or subfloor space between the finished structural ceiling and the floor above for access to the overhead mechanical and electrical services for a building.

-J-

JACK RAFTER. Short beam in hip roof work.

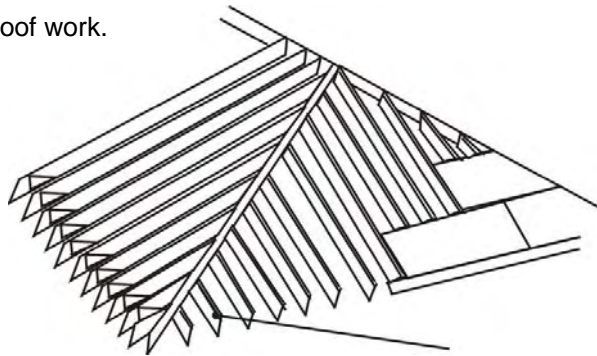

JALOUSIE. Adjustable glass louvers in doors or windows to regulate light and air or exclude rain.

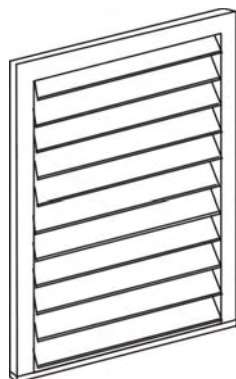

JAMB. The side framing or finish of a doorway or window.

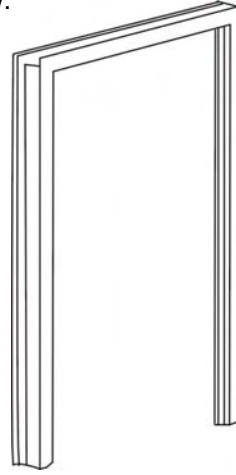

JOIST. Any of the parallel beams that support the subfloor or the ceiling.

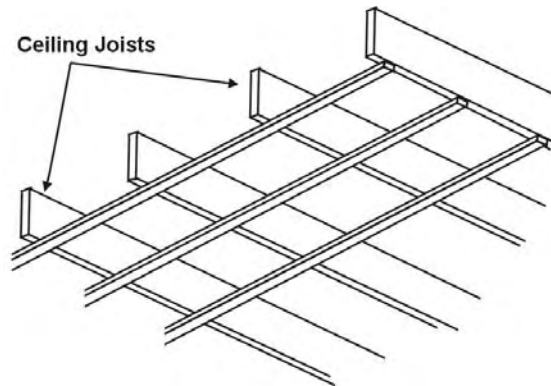

JOIST HANGER. A metal stirrup fastened to a supporting structural member that supports the end of a joist .

JOISTED MASONRY CONSTRUCTION. A building where the exterior walls are constructed of masonry materials such as brick, concrete, gypsum block, hollow or solid concrete block, stone, tile, or similar materials. The structural floors and roof are wholly or partly of wood or other combustible material.

-K-

KILOWATT. A measurement or unit of power equal to 1,000 watts or approximately 1.34 horsepower.

KILOWATT-HOUR. A unit of electrical energy consumption equal to 1,000 watts operating for one hour.

-L-

LABELED DOOR. A door that has been approved and carries a label by Underwriters Laboratories to indicate its fire resistive time classification.

LALLY COLUMN. A trade name for a pipe column from 3 to 6 inches in diameter sometimes filled with concrete.

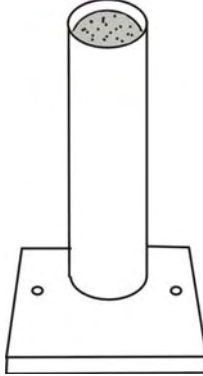

LAMELLA ROOF STRUCTURE. An arched roof-framing structure identified by the diamond-shaped arrangements of the pieces of plank or steel from which it is formed.

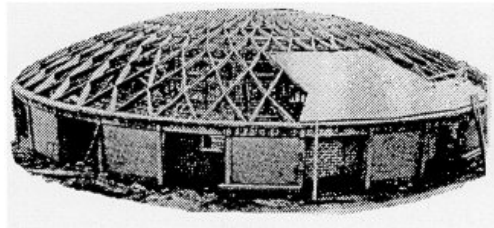

LAMINATED BEAM. A straight or arched beam formed by built-up layers of wood. The method of lamination may be by gluing under pressure, by mechanical nailing or bolting, or a combination.

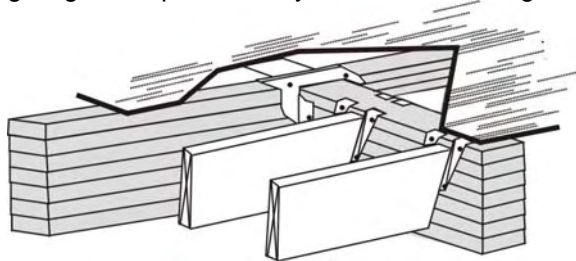

LAMINATED PLASTIC. Paper or textile sheets soaked in synthetic resin, then sandwiched between thin layers; makes a stiff, glossy covering (Formica, common trade name).

LANDING. A platform between flights of stairs or the floor at the head or foot of a stairway.



LATH. Strips of wood or expanded metal used as base for plaster walls.

LEACH LINE. A perforated pipeline used to distribute sewage or other effluent through the soil.

LEAN-TO. A small structure with a single-pitch roof built against an outside wall of a building.

LIFT SLAB. A construction system in which the floor and roof slabs are cast at ground level and then jacked into position and fastened to columns .

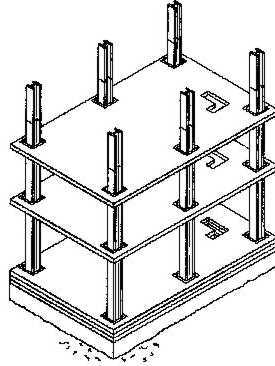

LIGHT WELL. A vertical unroofed shaft within a building designed to bring light and air to inside rooms.

LINEAR FOOT. A straight-line measurement of one foot as distinguished from a cubic foot volume or square foot area.

LINOLEUM. Floor covering made of solidified linseed oil, canvas, gum, and cork dust or wood flour.

LINTEL. A piece of wood, stone, or steel placed horizontally across the top of door and window openings to support the walls above the opening.

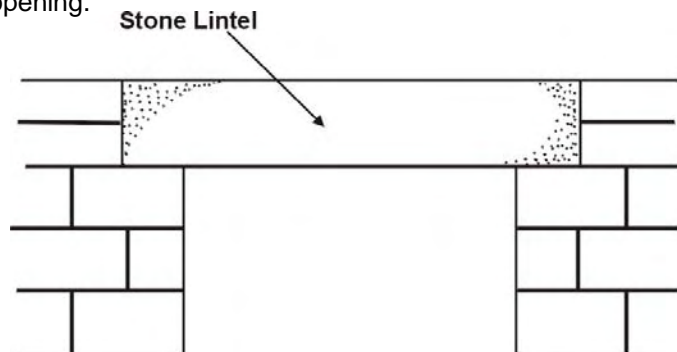

LIVE LOAD. Any moving or variable load applied to a structure, expressed in pounds per square foot of floor and roof areas for various types of building occupancy; e.g., weight of people, merchandise, or stock on a floor; snow load or wind pressure on a roof.

LOAD-BEARING WALL. Weight of wall and a portion of the floor and roof load are supported by the wall; the remainder is supported by the interior framing.

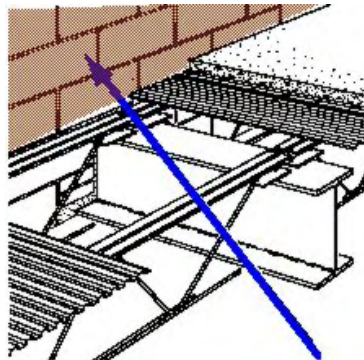

LOADING PLATFORM, LOADING DOCK. A platform adjoining the shipping and receiving door of a building, usually built to the same height as the floor of the trucks or railway cars on which shipments are delivered to and from the dock.

LOADING WELL. A fixed or adjustable inclined surface that adjoins a loading platform and is installed to ease the conveyance of goods between the platform and the trucks or railway cars that transport goods .

LOFT. (1) An attic-like space below the roof of a house or barn. (2) Any of the upper stories of a warehouse or factory.

LONG SPAN. The distance between supports in a structure, typically over 40', usually spanned by a truss or heavy timber.



LOUVER. A framed opening in a wall, fitted with fixed or movable slanted slats, useful in ventilating systems at air intake and exhaust locations.

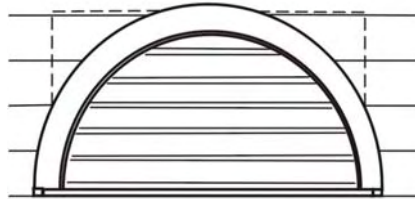

LUMINOUS CEILING. An area lighting system, mounted on a ceiling, that has a surface of light-transmitting materials with light sources installed above it.

-M-

MALL. A shaded walk or an area for pedestrians in a retail section or shopping center.

MANSARD ROOF. A roof with two slopes or pitches on each of the four sides, the lower slopes steeper than the upper. Convenient for adding another story to a building.

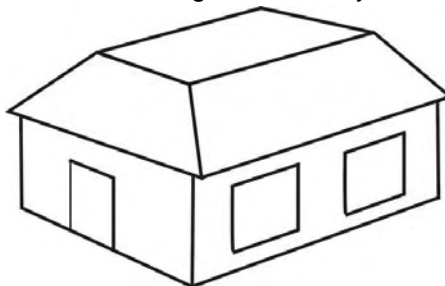

MARKET VALUE. “. . . the most probable price expressed in terms of money that a property would bring if exposed for sale in the open market in an arm’s-length transaction between a willing seller and a willing buyer, both of whom are knowledgeable concerning all the uses to which it is adapted and for which it is capable of being used.” (IAAO Property Assessment Valuation textbook).

MARQUEE. A roof-like structure over the entrance to a building and projecting from it. Usually cantilevered from the building .

MASONRY. Anything constructed of stone, brick, concrete, tile, or concrete block, using mortar as a bond.

MASONRY AND GLASS PANEL. An exterior curtain wall system consisting of thin set or modular brick or tile panels, or veneer on steel studs and glass panels hung on a frame.

MASONRY NON-COMBUSTIBLE CONSTRUCTION. A building where the bearing walls or bearing portions of walls, and the structural floors and roof and their supports are of unprotected non-combustible materials.

MASTIC. A heavy-bodied adhesive used to cement two surfaces, or an elastic caulking compound.

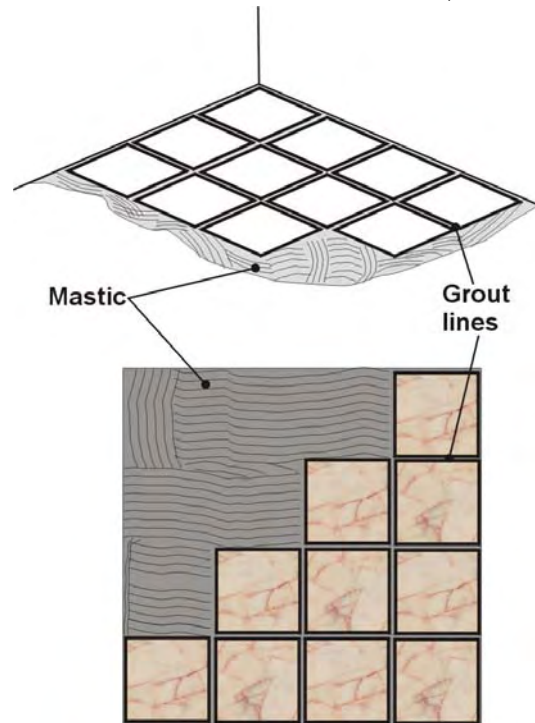

MAT FOOTING. A heavy concrete slab designed to spread the vertical forces from walls or columns over a wide area, after removing earth equal to the weight of superstructure. Often used to designate large spread footings.

MECHANICAL FEEDER. Auger, endless-chain, or slat system used to fill cattle feeding troughs.

MEMBRANE. A thin sheet or film of waterproof material used to prevent the movement of water through a floor, wall, or roof .

MERCURY VAPOR LAMP. An electrical discharge lamp that produces a blue white light by creating an arc in mercury vapor enclosed in a globe or tube. These lamps are classified as "low" pressure or "high" pressure.

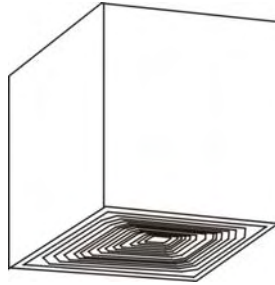

MESH. Heavy steel wire welded together in a grid and used as reinforcement for concrete work.

METAL LATH. A sheet of metal slit at intervals. When expanded, the grille-like panel forms a base for plaster, and or stucco.

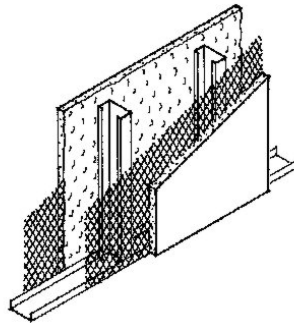

METAL PAN. A form used for placing concrete in floors and roofs.

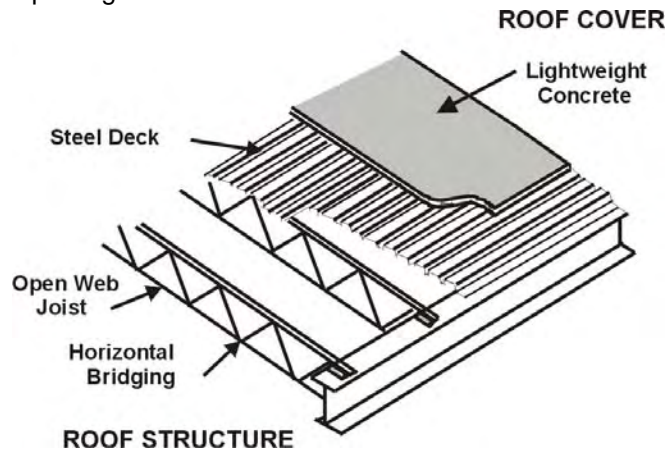

METAL PAN JOIST. A floor or roof system using metal pans to form a system of closely spaced beams and connecting slabs.

METAL-CLAD DOOR. Wood or fiber-core door with metal sheathing.

MEZZANINE. An intermediary floor having less area than the regular floors.

MHMA. Mobile Home Manufacturing Association.

MILL CONSTRUCTION. A type of fire-resistant or slow-burning construction; masonry walls, heavy timber framing, and planked or laminated wood floors much thicker than ordinary joist construction.

MILLWORK. Building units manufactured of finished wood in special millwork plants or planing mills; e.g., doors, window and doorframes, mantels, panel-work, stairways, and woodwork.

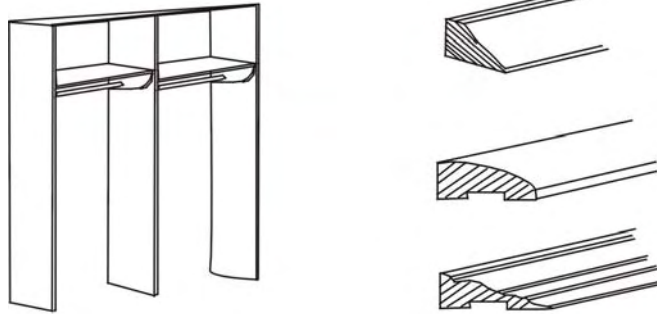

MISSION TILE. A clay roofing tile shaped like a longitudinal segment of a cylinder. The tile is used on sloped roofs with the concave side alternately up and down.

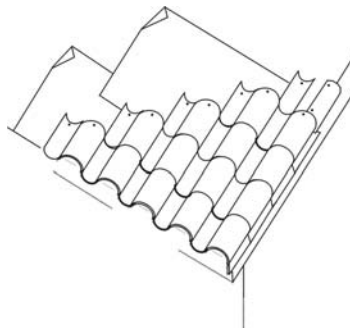

MODEL METHOD. A method of estimating the cost of a building on the basis of area, perimeter, and general construction. Uses simple arithmetic and component costs assembled to represent a specific occupancy.

MODIFIED FIRE RESTRICTIVE CONSTRUCTION. A building where the bearing walls or bearing portion of walls, and the structural floors and roof and their supports are of non-combustible construction with a fire resistance rating of not less than one hour.

MOLDING. Finishing wood to cover construction joints.

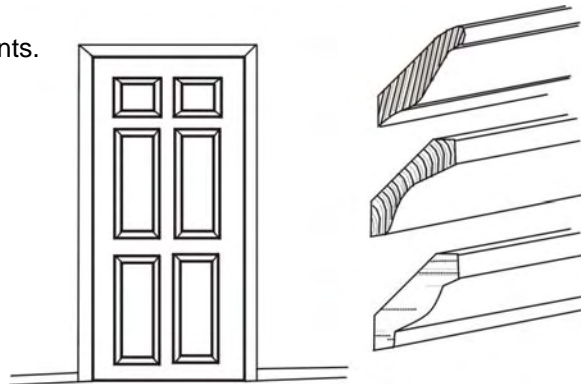

MONITOR ROOF. Raised structure on a roof having windows or louvers for ventilating or lighting the building, as a factory or warehouse.

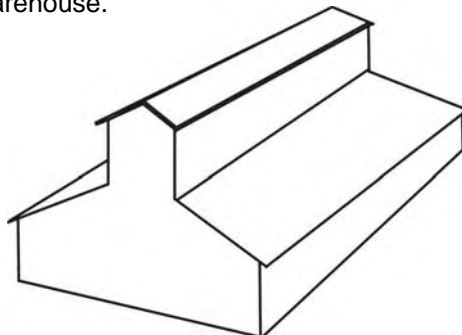

MONOLITHIC CONCRETE. Concrete that has been continually poured to form the floor, foundation, and stem wall in a single operation.

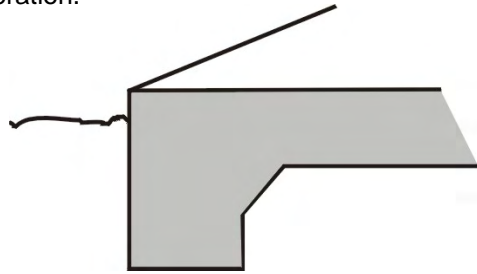

MORTAR. The bonding agent in masonry work made of lime, sand, and cement mixed with water.

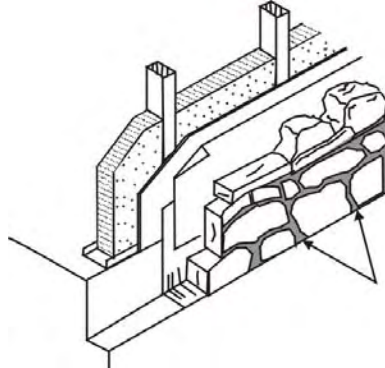

MORTISE. A notch or hole in a piece of material designed to receive a projecting part called a tenon in another piece of material in order to join the two.

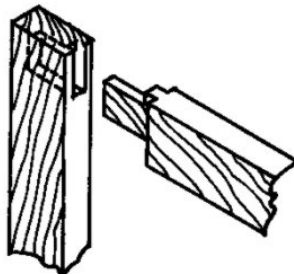

MOSAIC. A decoration made from small pieces of tile, stone, glass, or other material laid in mastic or mortar.

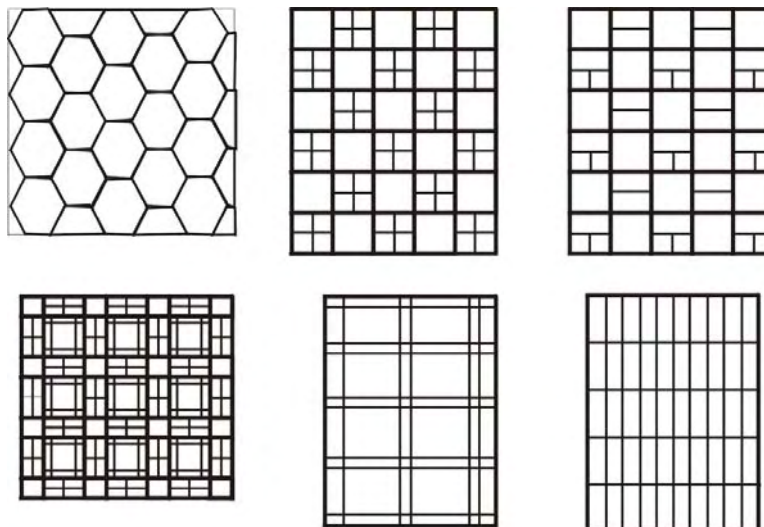

MUD SILL. Timber or plank laid directly on the ground to form the building foundation.

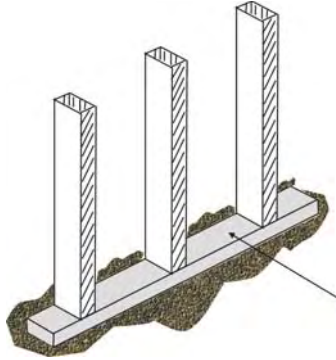

MULLION. Vertical dividing member between a series of adjoining doors, windows, or wall panels.

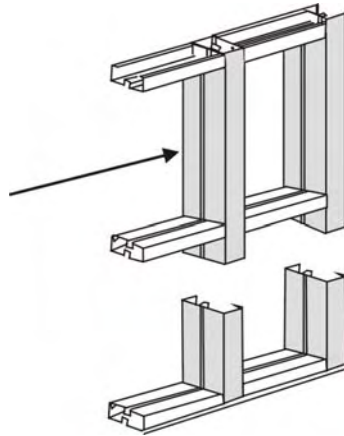

-N-

NEWEL. The post at the bottom of a stair or at the end of a flight of stairs, or the center pole of a spiral staircase.

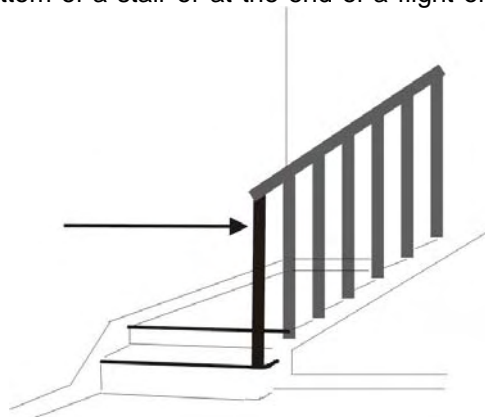

NON-BEARING WALL. A wall which supports only its own weight.

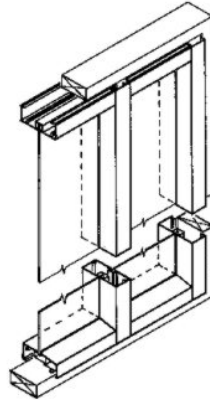

NON-COMBUSTIBLE CONSTRUCTION. A building that employs a system of prefabricated steel framing members. The roof is usually constructed of metal panels, the exterior walls of metal siding, sandwich panels, or masonry materials. Non-combustible construction is sometimes referred to as "pre-engineered."

NORMAL DEPRECIATION. The depreciation which could be expected to accrue to a building due to its age, maintenance, and design.

NORMAL LIFE. Reasonable life expectancy of a new building based on average experiences, normal wear, obsolescence, estimates derived from mortality data, and study of properties operating under average conditions.

-O-

OBsolescence. A form of depreciation divided into two categories: functional obsolescence and economic obsolescence. Functional obsolescence is loss of value due to lack of utility or desirability of part or all of the improvement. Economic obsolescence is loss of value due to causes outside the property and independent of it.

OCCUPANCY. (1) The designed use of a building. (2) The ratio of present space being used or rented to the designated full use, expressed as a percentage.

ON CENTER. The distance from the center of one structural member to the center of another. Term used for spacing studs, joists, and rafters.

ON GRADE. A concrete floor slab placed on A.B.C. or gravel in direct contact with the earth.

OPEN SYSTEM FOR CORRUGATED METAL. A roof system consisting of secondary members acting as a purlin support system. Light purlin supports rest perpendicular to and directly on the pre-engineered steel or wood pole frame to support the metal roof cover.

OPEN WEB. A form of construction on a truss or girder in which multiple members, arranged in zigzag or crisscross patterns are used in place of solid plates to connect chords or flanges.

OPEN WEB STEEL JOIST. A steel truss with an open web constructed of hot-rolled structural shapes or shapes of cold-formed light gauge steel.

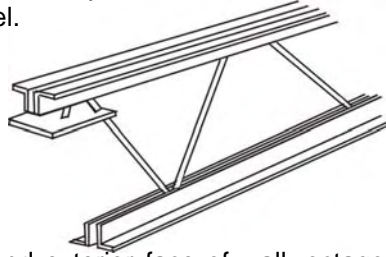

ORIEL. Window type; ordinarily projects beyond exterior face of wall; octagonal or hexagonal in plan, commonly corbelled or cantilevered out.

OVERHANG. An upper level projection of a building; extends beyond the lower structure.

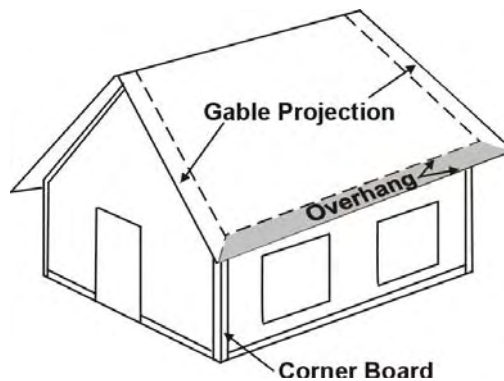

OVERHEAD DOOR. A door, constructed of a single leaf or of multiple leaves, that is swung up or rolled open from the ground level and assumes a horizontal position above the entrance way it serves when closed. Commonly used as a garage door.

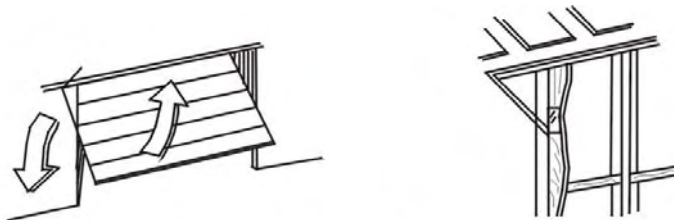

1-piece Swing-up Door

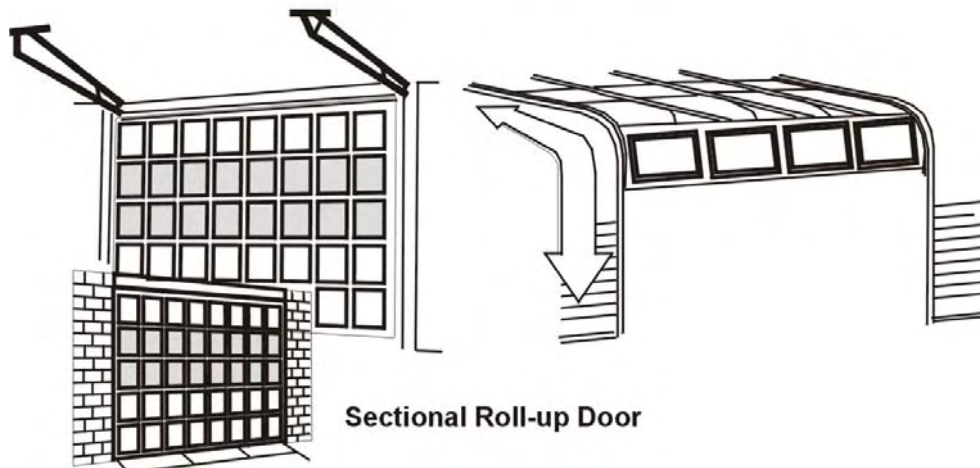

Sectional Roll-up Door

-P-

PACKAGE UNIT. Basically the same as central air (warm and cool air) except for the capacity and amount of ductwork involved. Typically, a package system contains one short duct and thermostat per unit, and it is not uncommon to find a number of individual units servicing one building. A split system is a type of package that as gas-fired, forced-air heating with either gas or electric refrigerated cooling. These are complete, individual, roof-mounted units or ground units each having its own individual compressor and furnace.

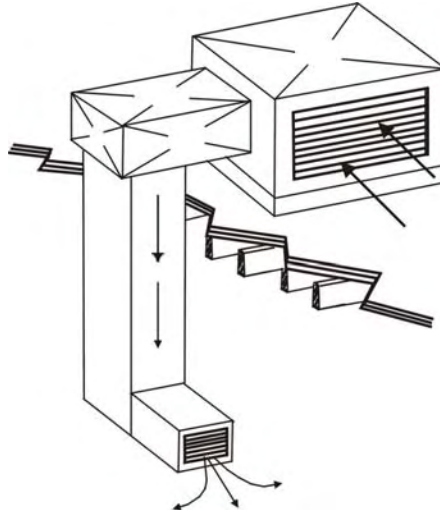

PAN. A prefabricated form unit used in concrete joist floor construction.

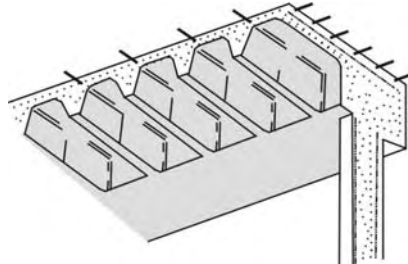

PANEL. A section of a surface, such as a wall or ceiling, which is either raised or recessed and usually enclosed in a frame-like border.

PANEL, PREFABRICATED. An assemblage of construction components into relatively thin units. Allows placement as a unit, i.e., wall panels, floor panels, or roof panels etc.

PANEL WALL. A prefabricated section of wall erected in one piece.

PARAMETER. Any characteristic of a statistical universe which is measurable. In construction, square foot, cubic yard, and board feet are all parameters .

PARAPET. (1) A low wall along the edge of the roof, balcony, ridge, or terrace. (2) That portion of the wall that extends above a flat roof.

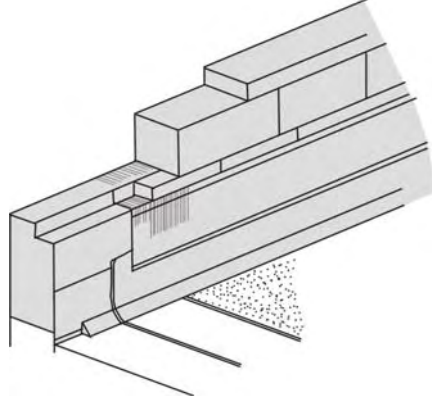

PARGING. A coating of cement on a masonry wall, frequently used to waterproof the outside surface of a basement wall.

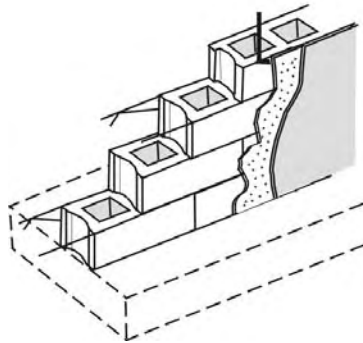

PARQUET FLOORING. A floor covering composed of small pieces of wood, usually forming a geometric design.

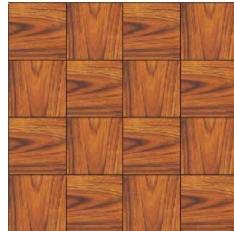

PARTIAL COMPLETE. An improvement that is not 100% complete for the current assessment year. Indicated by a "1" code; accompanies any entry in the percent complete field of the data collection form.

PARTICLE BOARD. A generic term used to describe panel products made from discrete particles of wood or other lignocellulosic material rather than from fibers. The wood particles are mixed with resins and formed into a solid board under heat and pressure.

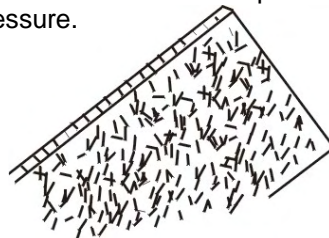

Particleboard

PARTITION. A dividing wall between rooms or areas.

PARTY WALL. A wall built along the dividing line between adjoining buildings for their common use.

PATIO. An outdoor area, usually paved and sometimes shaded, adjoining a building.

PAVER. A block or tile used as a wearing surface.

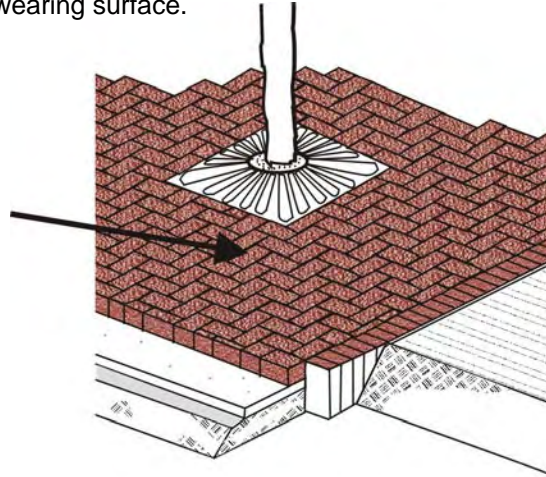

PENTHOUSE. A structure or enclosure on a roof normally used for housing the stairway to roof, elevator machinery, a utility room, cover for a water tank, or residence.

PERIMETER. The total length of the periphery of a given area; e.g., equals the distance around the outside of a building.

PIER. A platform structure supported by pilings, extending from land into water. Also a short column which supports a superstructure.

PILASTER. An upright pier or column attached to, or projecting from, a wall. Typically used as vertical support for roof structure.

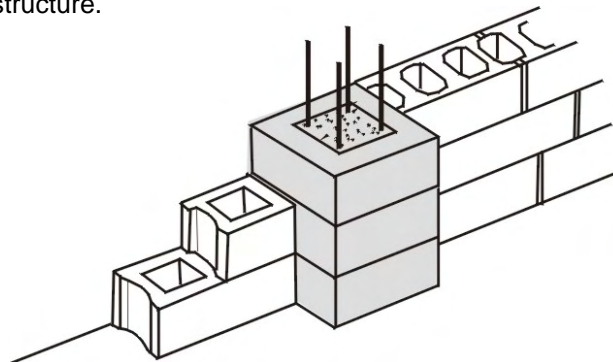

PILE. A timber, steel, or concrete shaft which is driven into the ground to serve as support for a foundation.

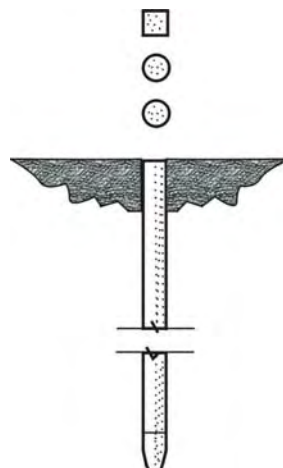

PITCH. The slope or incline of a roof, expressed in inches of rise per foot of length, or by the ratio of the rise to the span.

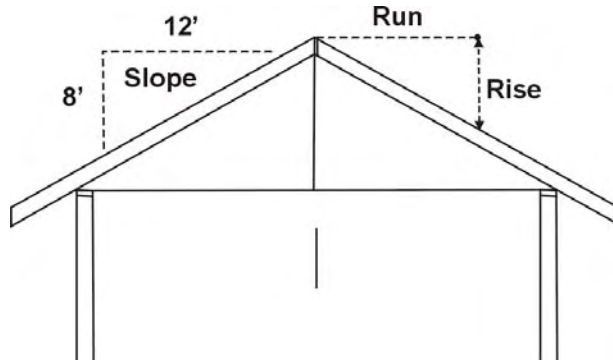

PLASTER. A mixture of lime, sand, and water. Used as a finished surface for walls and ceilings.

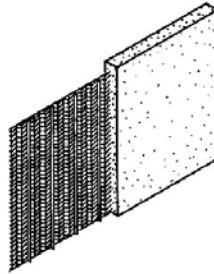
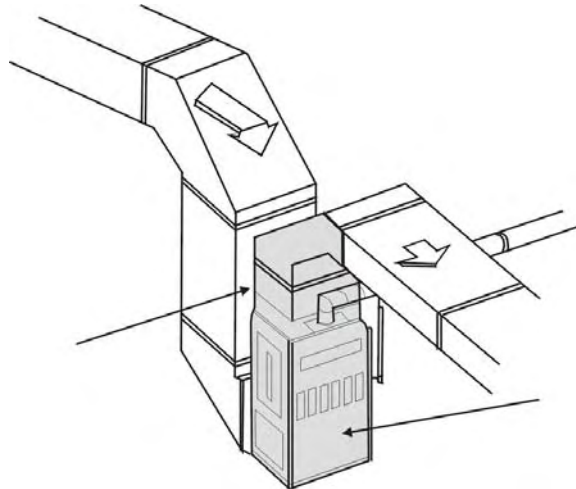

PLATE. The top horizontal structural member of a frame wall.

PLENUM. A closed chamber used to distribute or collect warmed or cooled air in a forced-air heating/cooling system.



PLYWOOD. A fabricated wood product constructed of three or more layers of veneer joined with glue, usually laid with grain of adjoining plies at right angles.

PNEUMATIC CONTROL SYSTEM. A system in which control is effected by pressurized air.

POLE FRAME. Building structural skeleton consisting of cylindrical timbers generally with the bark removed, and treated with preservative.

PORCH. A roofed structure providing shelter at the entrance of a building.

PORTICO. A covered walk consisting of a roof supported on columns; a colonnaded (continuous row of columns) porch.

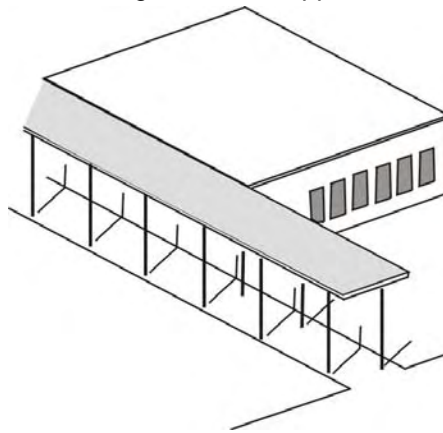

PORTLAND CEMENT. A properly proportioned mixture of calcareous (containing calcium carbonate) and clayey materials which are heated and pulverized, and when mixed with water hardens into a solid mass. Named because it resembles stone from quarries near Portland, England.

POST. A vertical structural member carrying stresses in compression, used where strength in bending is not a requisite.

POWER FEED WIRING. The main electric power line entering a building from a utility or private source; supplies electric power to machinery and equipment through main bus ducts or heavy wiring in conduit. Does not include branch feed lines or controls from main line to machinery.

PRECAST CONCRETE. Concrete structural components that are cast separately, either at a separate location or on a building site, not formed and poured in place in the structure.

PRE-ENGINEERED BUILDING. A building constructed of pre-designed, pre-manufactured, and pre-assembled units such as wall, framing, floor, and roof panels. Pre-engineered units are simply erected at the construction site.

PRESTRESSED CONCRETE. A structural member with reinforcing strands placed under tension either before or after the concrete sets.

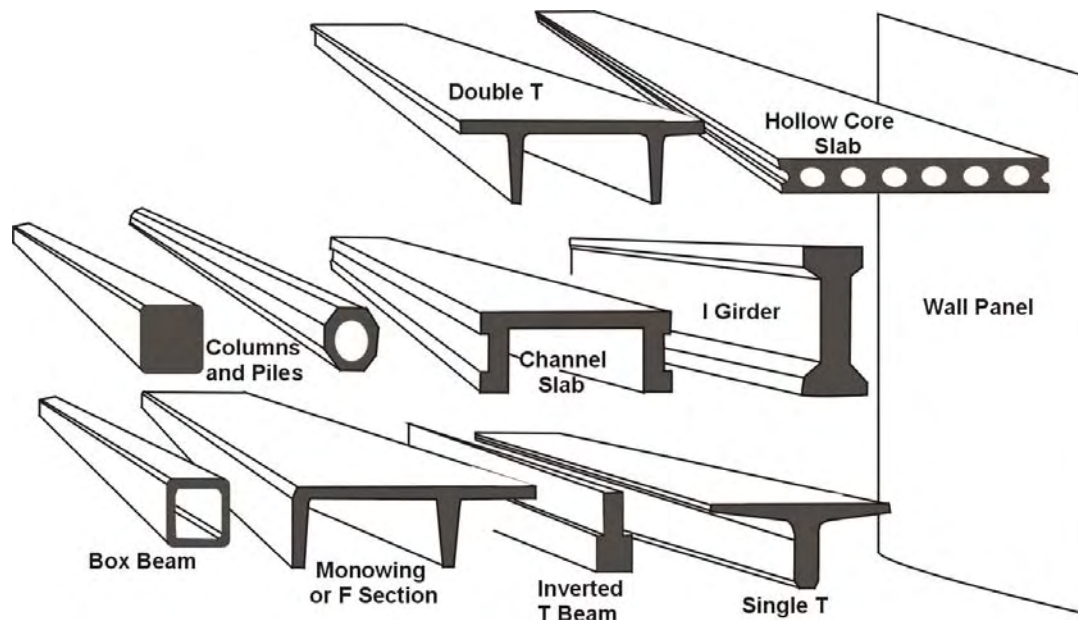

PURLIN. A structural member laid horizontally to support the roof deck and the common rafters.

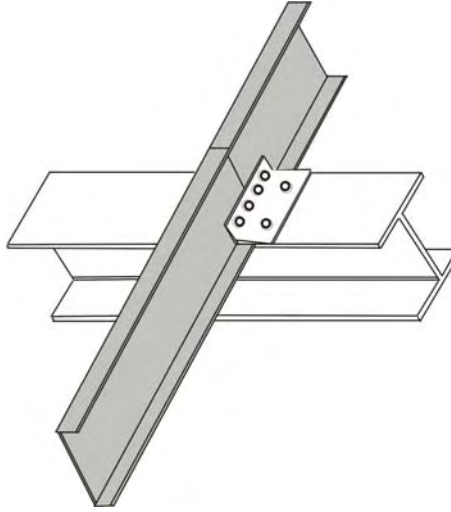

-Q-

QUONSET HUT. A prefabricated building with a semicircular cross section usually built with corrugated steel.

-R-

R VALUE. The standard measurement of resistance to heat loss related to a given thickness of insulation required by climatic demands.

RADIANT HEATING SYSTEM. A heating system which transfers heat in the form of waves or particles to be naturally circulated throughout the space.

RAFTER. Structural members (joists or beams) which shape and form the support for the roof deck (or sheathing) and the roof covering.

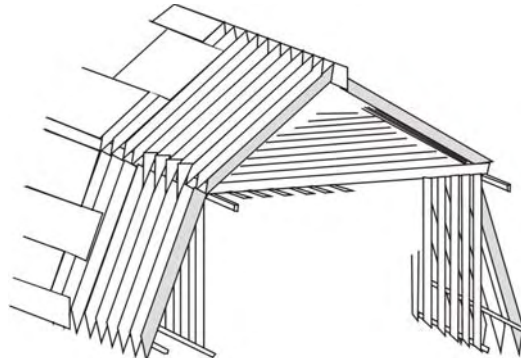

RAILING. A solid wood band around one or more edges of a plywood panel; a balustrade.

RAMMED EARTH. A mixture of aggregate and water which has been compressed and dried.

RATIO. Ground area of building or average total floor area divided by wall perimeter; e.g., building 50'0" x 200'0" = 10,000 square feet of ground area divided by 500 linear feet of perimeter = 20 ratio. Thus, the building has 20 square feet of ground area for each linear foot of perimeter.

REBAR. Rods used to reinforce concrete construction, bond beams, and foundations/footings.

RECEPTACLE. A contact device installed in an electric outlet box for the connection of portable equipment or appliances to an electric circuit.



REFRIGERATION SYSTEM. A system in which a refrigerant is compressed, condensed, and expanded as a means of removing heat from a cold reservoir. The heat is rejected elsewhere at a higher temperature.

REINFORCEMENT. A system of steel rods or mesh for absorbing tensile and shearing stresses in concrete work, complementing the inherent compressive qualities of concrete.

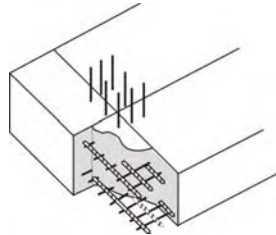

REMAINING LIFE - REMAINING ECONOMIC LIFE. Projected estimate of a date that a property can no longer perform economically. Also remaining serviceable life or remaining useful economic life.

REPLACEMENT COST. Cost estimate based on the cost to construct a building of like utility using modern design, materials, and workmanship.

REPRODUCTION COST. Cost estimate based on the cost to construct an improvement that duplicates the subject structure in every detail.

RESILIENT FLOOR COVERING. Floor covering products characterized by having dense, nonabsorbent surfaces, available in sheet or tile form. Among the various types are vinyl composition (asbestos) tile, asphalt tile, vinyl tile, and linoleum.

RETAINING WALL. A wall built to keep a bank of earth from sliding or water from flooding.

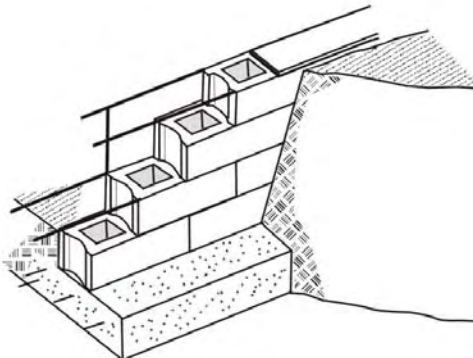

RIGID INSULATION. Insulation made of foamed plastic or glass, cork, or pulp (wood, cane, etc.) and assembled into lightweight boards.

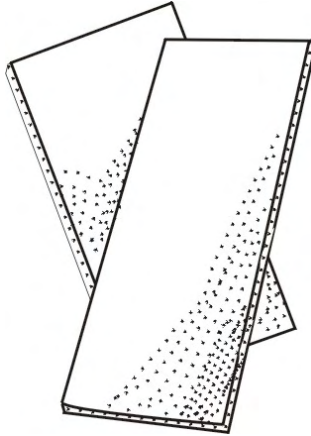

RISE. Distance rafter extends in vertical direction. Also measurement of height of individual step.

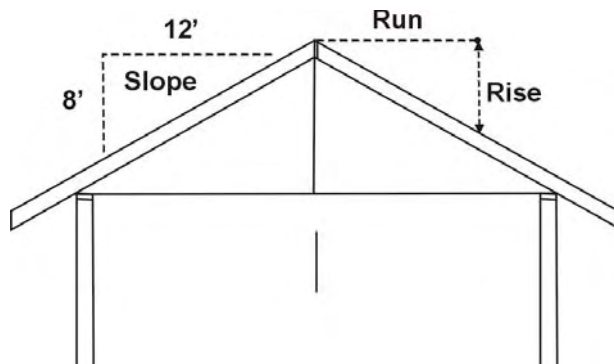

RISER. The vertical member between two stair treads.

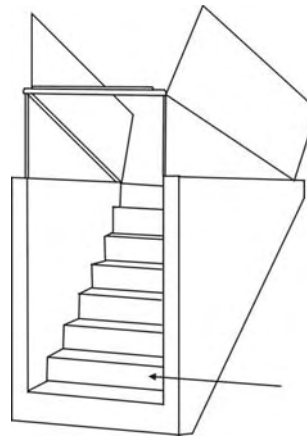

ROLL ROOFING. Material of fiber saturated with asphalt; supplied in rolls .

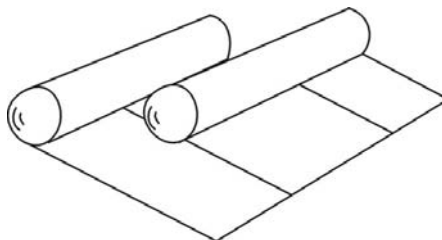

ROLL-UP DOOR. A device consisting of horizontal interlocking metal slats that ride along wall guides. When the door is opened, the slats coil around a barrel assembly located above the door.

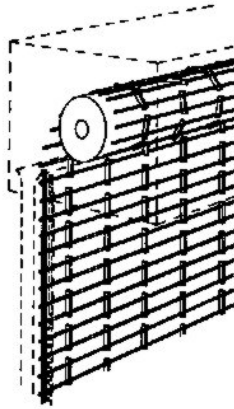

ROMEX. Nonmetallic sheathed wiring commonly used in residential construction.

RONDEL. Round.

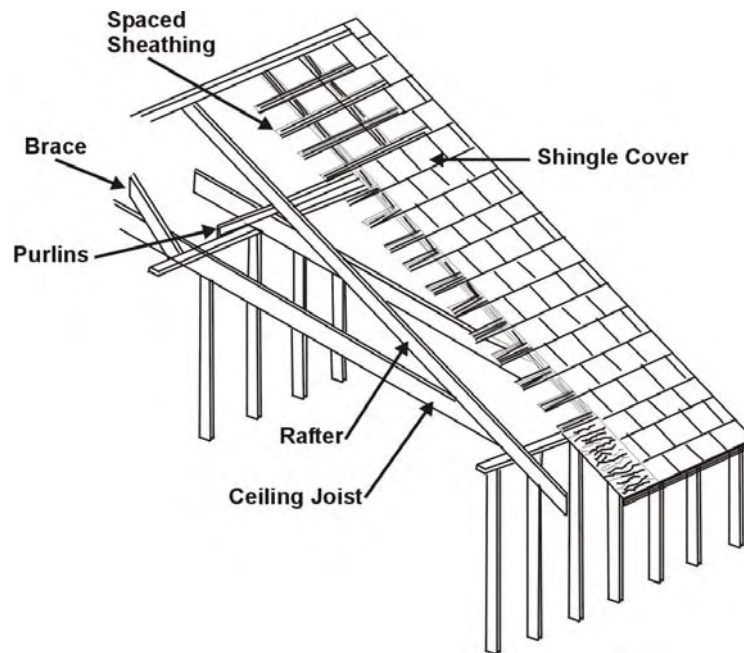

ROOF STRUCTURE. The supporting structure for the outer covering of the top of a building.

ROTUNDA. A circular building or room covered by a dome.

RUN. The horizontal distance spanned by a rafter or electrical passageway.

-S-

SALTBOX. A wood-framed house, common in colonial New England, with a short pitched roof in front and a roof which sweeps close to the ground in back.



SALVAGE VALUE. The total of any remaining value of the physical components of an improvement after it has reached the end of its economic life. A net sum over and above the cost or removal and sale, which may be zero or even a negative.

SANDWICH PANEL. A core of insulation covered on both sides with such materials as concrete, metal, or asbestos.

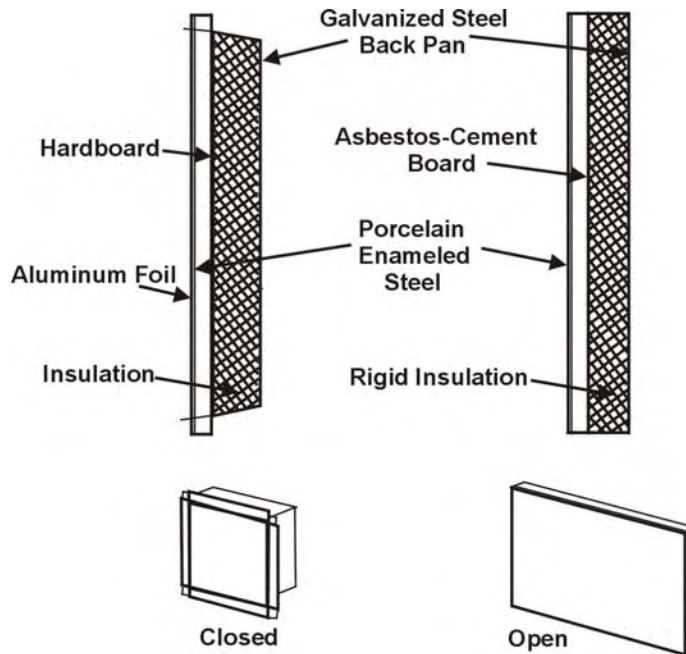

SASH. The framework which holds the glass in a window or door.

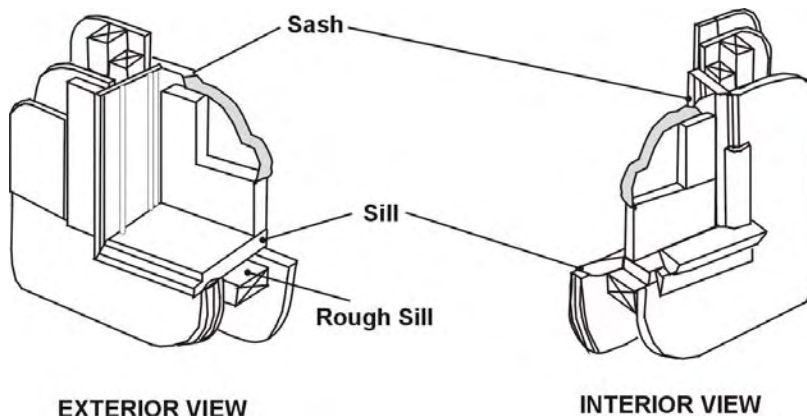

SAWTOOTH ROOF. A roof composed of a series of single-pitch roofs whose shorter or vertical side has windows for light and air.

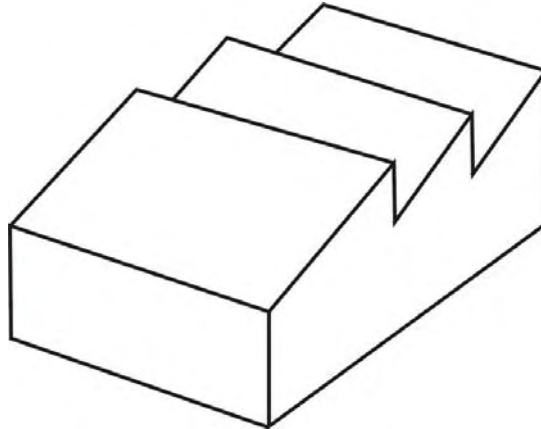

SCR BRICK. Brick whose nominal dimensions are 2 2/3" x 6" x 12" as designated or classified by the Structural Clay Research (trademark of Structural Clay Products Institute). It will render 3 courses in 8" and will render a wall whose nominal thickness is 8".

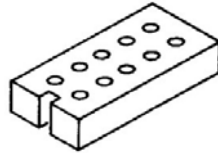

SCUPPER. An opening through a parapet wall, slightly above the roof level and possibly adjacent to a downspout which provides drainage for a flat roof.

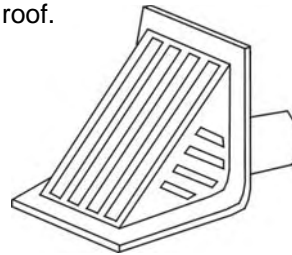

SECTION. A drawing of a building as it would appear if cut straight through on a vertical plane.

SEGREGATED COST METHOD. A cost method that separates the construction of a building into elements or related groups such as floors, walls, roofs, electrical, and plumbing and then prices these as components or units. The sum of these and any other pertinent components then equals the RCN of the building.

SEPTIC TANK. A covered tank in which waste matter is decomposed by natural bacterial action.

SEWAGE EJECTOR. A lift pump which raises sewage to sewer mains.

SEWAGE TREATMENT PLANT. Structures and appurtenances that receive raw sewage and bring about a reduction in organic and bacterial content of the waste so as to render it less dangerous and less odorous.

SHAKE. A shingle formed by splitting a short log into a number of tapered radial sections.

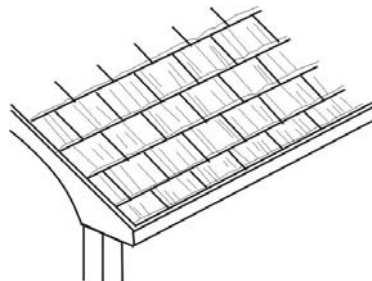

SHEATHING. The first covering of boards, plywood, or wallboard placed over exterior wall studding or roof rafters.

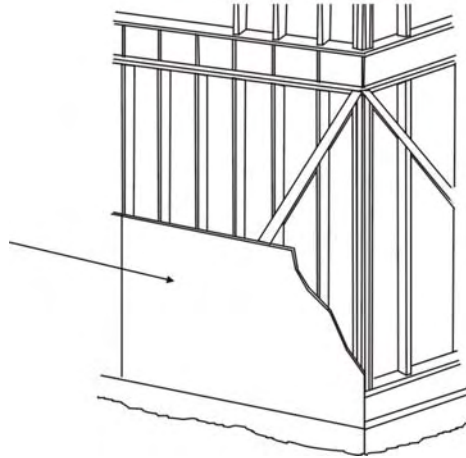

SHED ROOF. A roof having a single sloping plane.

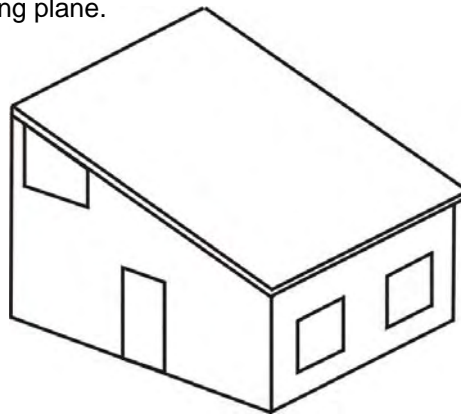

SHEET PILING. Planking or steel shafts driven close together vertically to form a temporary wall around an excavation.

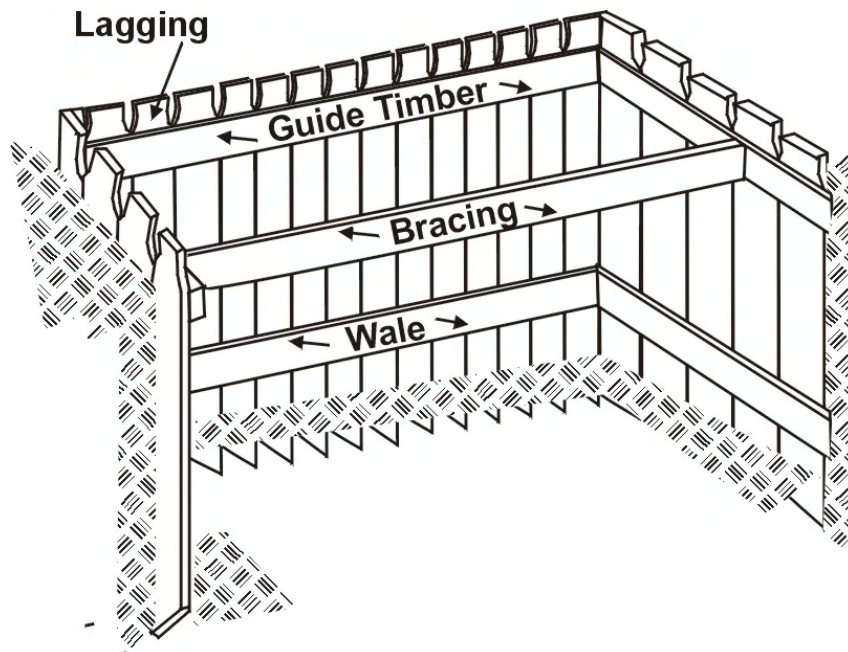

SHINGLE. A thin wedge-shaped slat or board laid with others in a series of overlapping rows as a covering for roofs or walls.

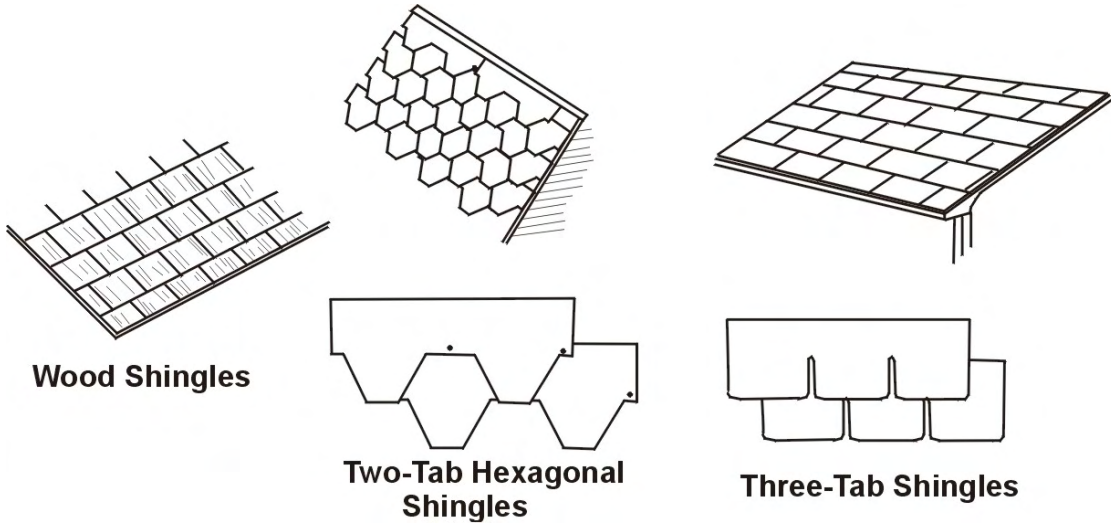

SHORING. Structural bracing used as temporary support for a building construction.

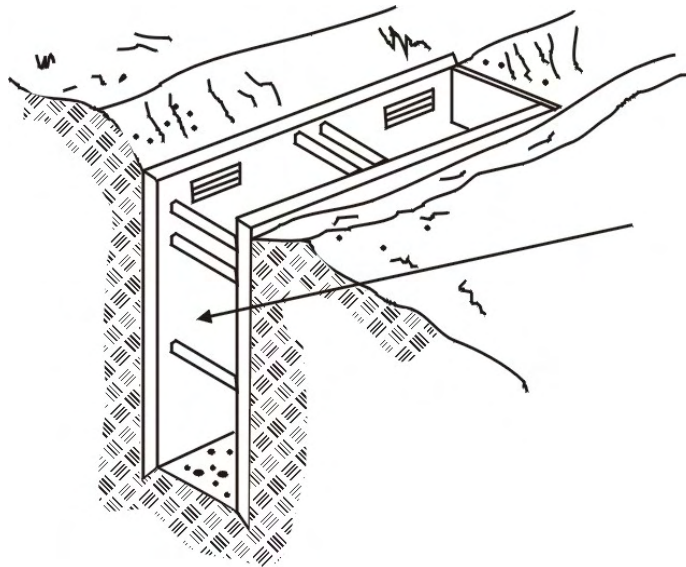

SHORTSPAN JOIST. An open web joist, typically 12" to 24" in a depth designed to span a distance from 16' to 40'.

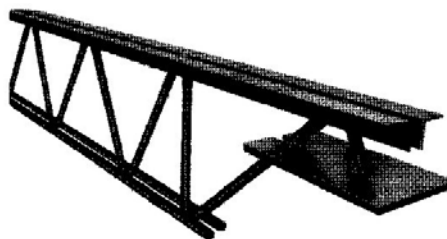

SIAMESE CONNECTION. A Y branch connection on the outside of a building with two inlet connections, used by the fire department to supply water to a sprinkler and/or standpipe system.

SIDING. A finish covering for exterior walls of a building.

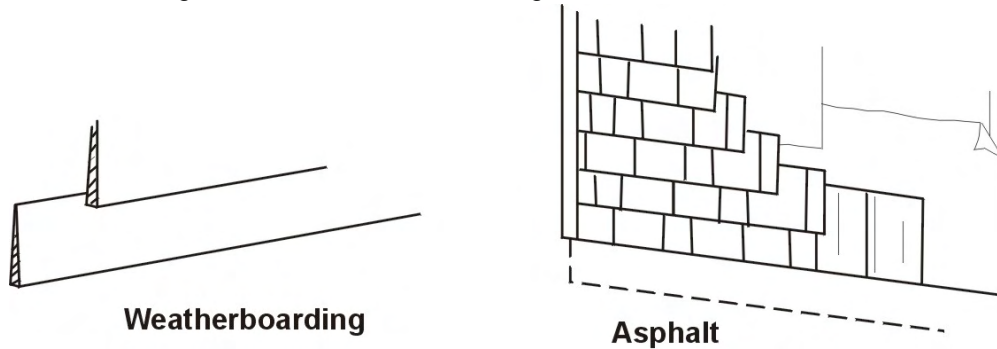

SILL. A horizontal piece forming the bottom frame of a door or window. A heavy horizontal timber or line of masonry supporting a superstructure.

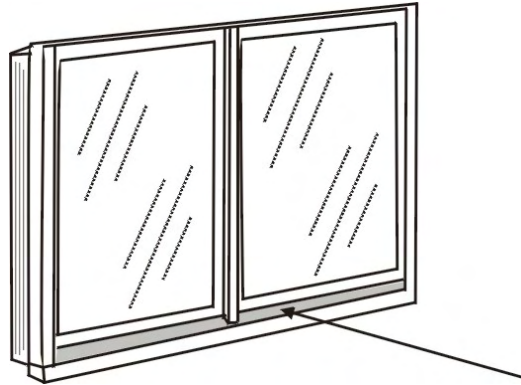

SILO. A tower-like structure, usually cylindrical, used to store items such as grain, coal, or minerals.

SINGLE WALL CONSTRUCTION. Each of the non-load-bearing wall types listed under the single-wall construction category refers to a wall enclosure that is typically applied over an open skeleton prefabricated metal or wood pole-framed building. That frame characteristically has the same configuration for each cover. The costs include the costs of the horizontal wall supporting girts and cover but not the framing.

SKIN WALL. External wall covering of aluminum, porcelain enamel, steel, or other material.

SKIRTING. Trim which hides the undercarriage of a mobile home. It continues the wall line of the mobile home to the ground.

SKYLIGHT. A glassed opening in a roof.

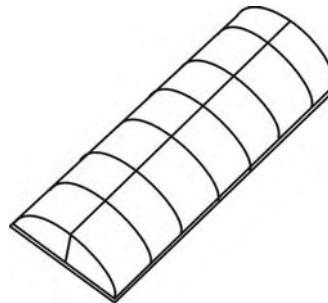

SLAB. A piece that is broad, flat, fairly thick, and made of wood, stone, concrete, or other solid material.

SLAB ON GROUND. A building floor (usually concrete) that rests on, or touches, the ground.

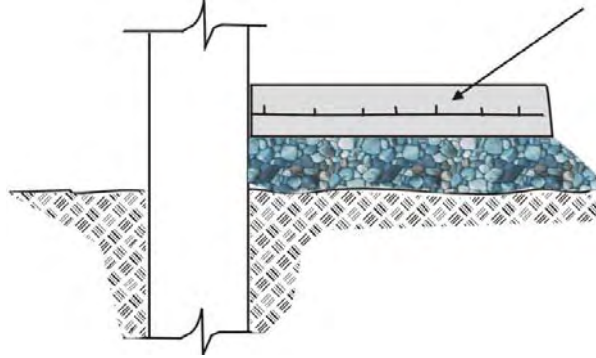

SLATE. A fine-grained metamorphic rock possessing a well-developed fissility (slaty cleavage) usually not parallel to the bedding planes of the rock.

SLIDING WINDOW. A type of window containing two movable sashes set in separate grooves permitting the sashes to slide horizontally past each other.

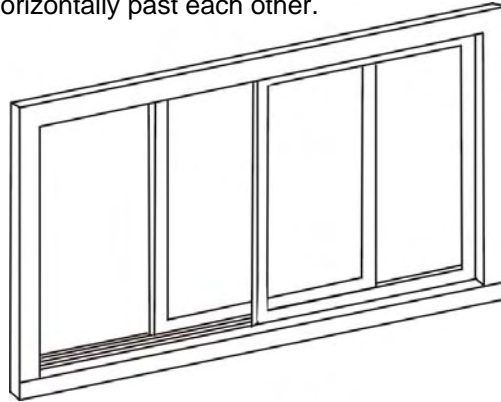

SLIP FORM CONSTRUCTION. In concrete construction, forms that move continuously are jacked upward or forward supported by the concrete which was poured previous, shaping the new pour as it moves.

SLOPE. The ratio of the rise to the run of the roof angle. In the illustration below, the rise divided by the run would be 8:12 resulting in a slope factor of 6. See Volume 1, Section 3 for more information.

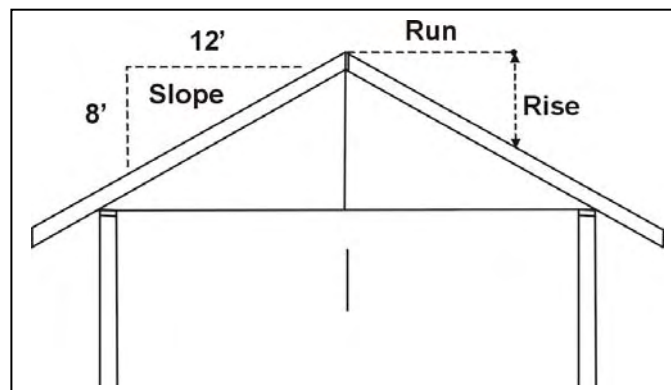

SLUMP BLOCK. Concrete blocks having a rough surface resembling adobe brick.

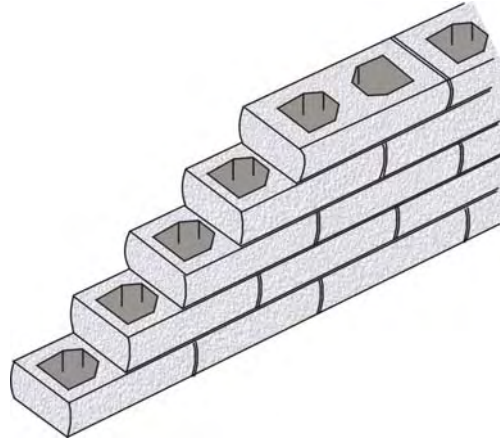

SOFFIT. The undersurface of a building member such as an arch, cornice, overhang, or stairway.



SOFTWOOD. Wood from conifers, such as redwood, cedar, pine, fir, etc.

SOLAR HEATING SYSTEM. An assembly of components, including collectors, heat exchangers, piping, storage system, controls, and supplemental heat source, used to provide heat and/or hot water to a building, with the sun as the main source of energy.

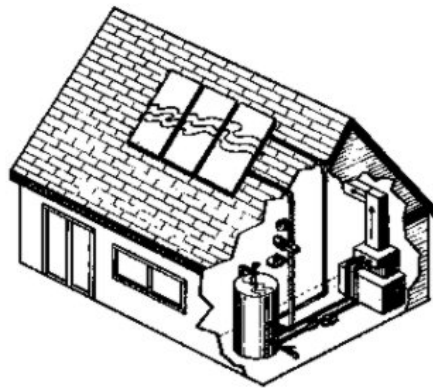

SOLID-CORE DOOR. A door having a core of solid wood or mineral composition, as opposed to a hollow-core door.

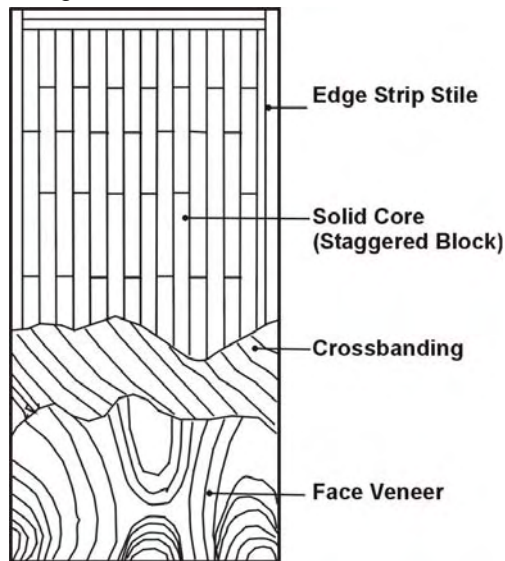

SPACE FRAME. A three-dimensional truss-like framework used to span a rectangular area whereby the individual members are so interconnected that a truss effect is achieved to carry imposed loads to all four support sides.

SPACE HEATER. A small heating unit usually equipped with a fan, intended to supply heat to a room or portion of a room. The source of heat energy may be gas, electric, or liquid fuel.

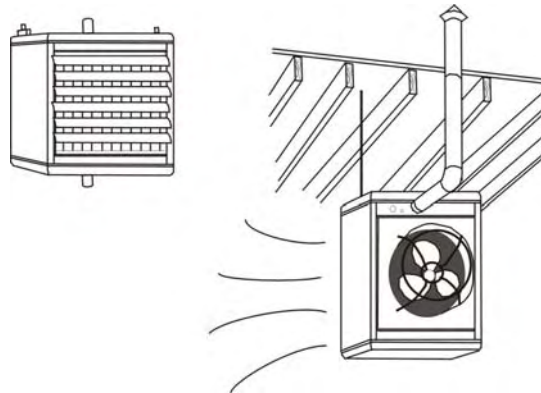

SPAN. The horizontal clear distance between supports, as between those of a bridge, or between columns of a structure.

SPANDREL. Portion of exterior wall between two piers or between window on one floor and window on floor above.

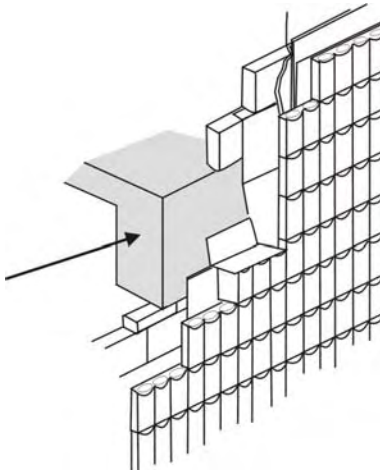

SPANDREL GLASS. Opaque glass used in curtain wall construction to conceal structural elements.

SPECIFICATIONS. A detailed description of requirements, materials, etc., of a building.

SPIRAL STAIRS. A flight of stairs whose treads wind around a central newel in a spiral or helix shape.

SPIRE. Pyramidal apex of tower; a top part tapering upward. Any long, slender, pointed construction on top of a building.

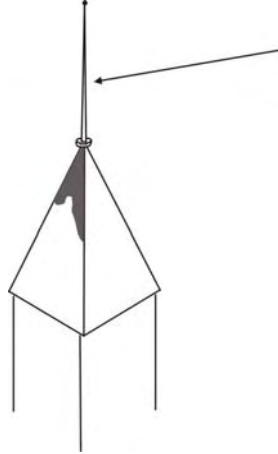

SPLASHBOARD. A board placed on a wall at a sink to protect the wall.

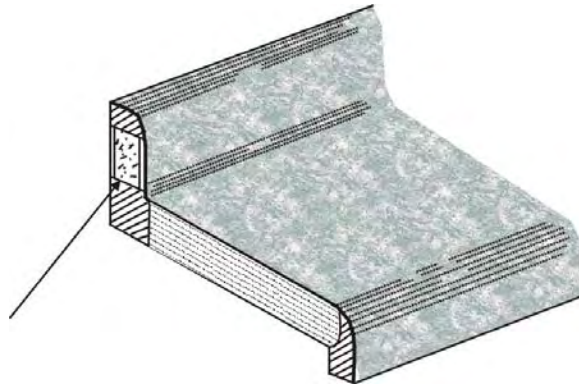

SPLIT-FACE BLOCK, SPLIT BLOCK. Concrete masonry unit with one or more faces produced by purposeful fracturing of the unit, to provide architectural effects in masonry wall construction.

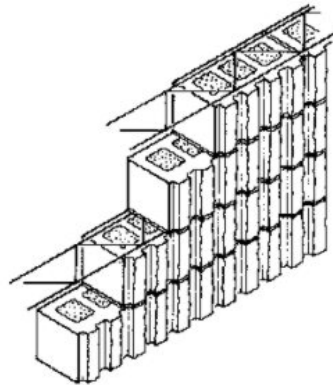

SPREAD FOOTING. A generally rectangular prism of concrete larger in lateral dimensions than the column or wall it supports, to distribute the load of a column or wall to the subgrade.

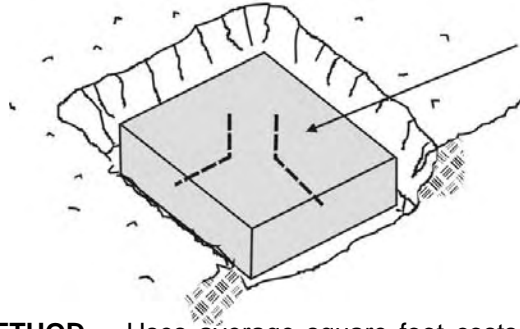

SQUARE FOOT COST METHOD. Uses average square foot costs for typical buildings to value improvements.

STACK. Vertical waste or vent pipe.

STAINED GLASS. Glass given a desired color by use of an additive to the molten material, or by firing a stain into the surface of the formed glass. Stained glass is used for decorative windows or mosaics.

STANCHION. A vertical post or prop supporting a roof, window, etc.; an upright bar or post, as in a window, screen, or railing.

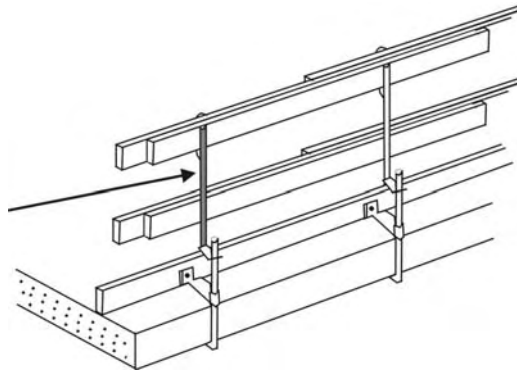

STANDPIPE. An interior or exterior pipe to conduct water to upper floors for fighting fires. May be dry, with connection for pumper at street level, or wet, with water always at the upper floors. Also, a tall cylindrical water storage tank.

STAY-IN-PLACE FORMING. A wall constructed of poured-in-place concrete, where the forming material remains in place. The reinforcing is usually a bar set in a grid pattern within the form for the concrete wall. Forms used for the wall are usually some type of a rigid insulation board or metal panel and finish system. Thickness of these walls varies depending on the structural requirements of the building.

STEAM HEAT. A heating system in which steam is generated using a boiler and piped to radiators throughout the building by its own pressure. Steam without a boiler is a radiator system receiving steam from an external source such as a central steam plant or adjoining building.

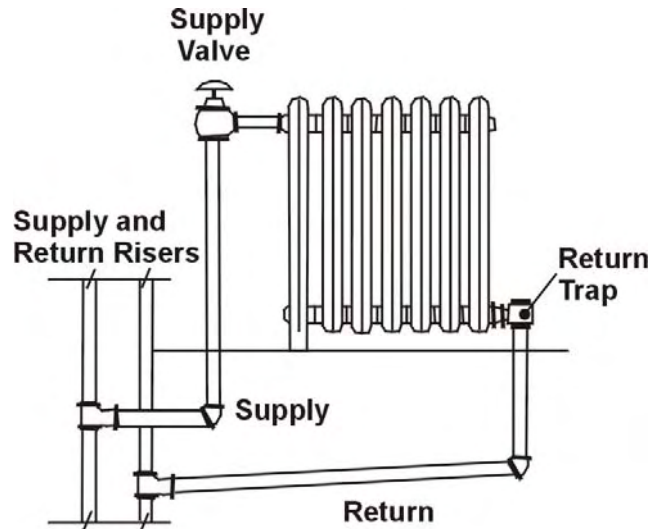

STEEPLE. A tall tower forming the superstructure of a building, as a church or temple and usually surmounted by a spire; a spire.

STOCK-TYPE PLANS. Plans that can be purchased commercially.

STOREFRONT. Glass front wall area typically found on department and retail stores. Storefront includes glass, opaque panels, wood or metal frame, lighting, and entrance doors.

STORY. A horizontal division of a building between one floor and the next floor area.

STRUCTURAL. A term applied to those members of a structure that carry an imposed load in addition to their own weight.

STRUCTURAL FLOORS. Floors above the ground resting on walls or columns.

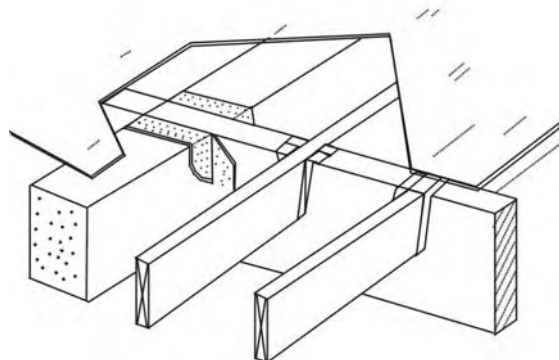

STRUT. A brace or other member which resists stresses in the direction of its own length.

STUCCO. A cement plaster used as an exterior wall surface; usually applied over a metal or wood lath base.

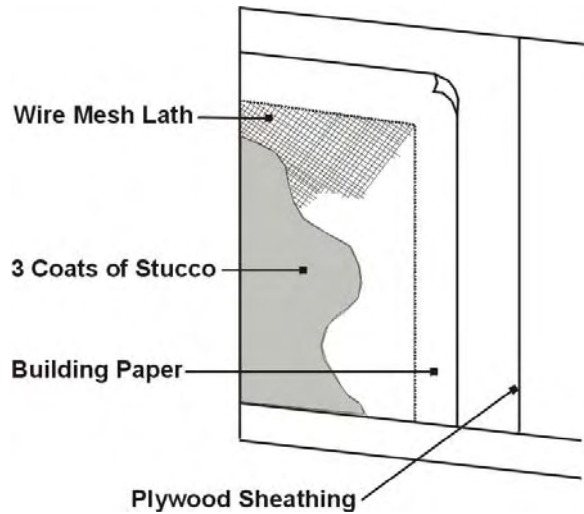

STUD. A vertical wood or metal framing member to which horizontal boards or laths are nailed; e.g., the supporting elements in walls and partitions.

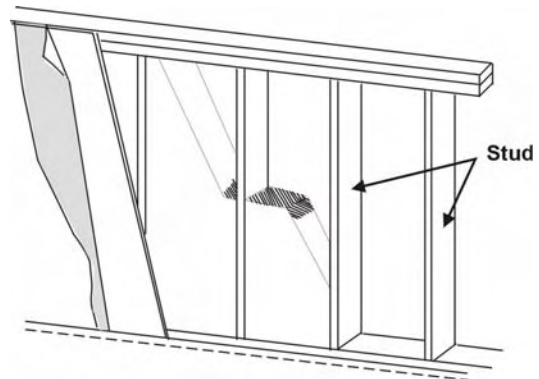

SUBFLOOR. A floor laid on top of the floor joists to which the finished floor is fastened.

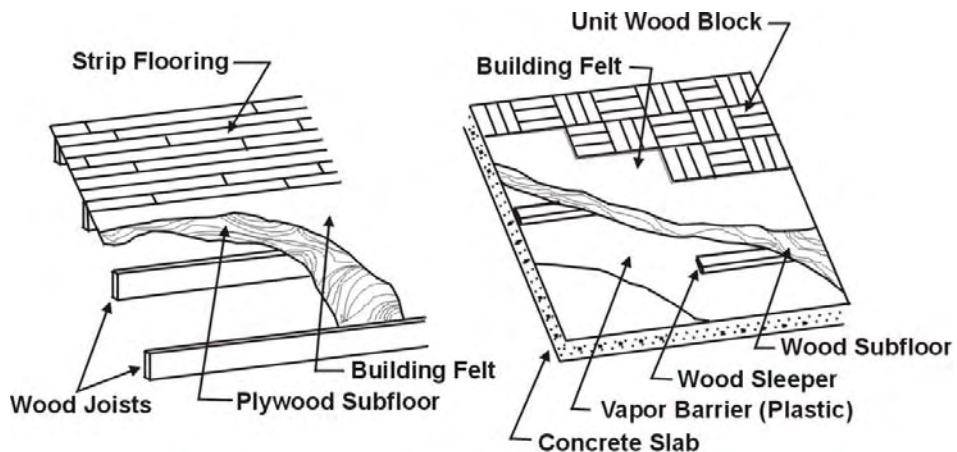

WOOD SUBFLOOR

CONCRETE SUBFLOOR

SUBSTRUCTURE. That part of the building below the top of the foundation or basement.

SUPERSTRUCTURE. That part of a building above the foundation or ground level.

SUSPENDED CEILING. This is the grid (track, T-bar, etc.) suspension system that supports an acoustical panel or tile ceiling.

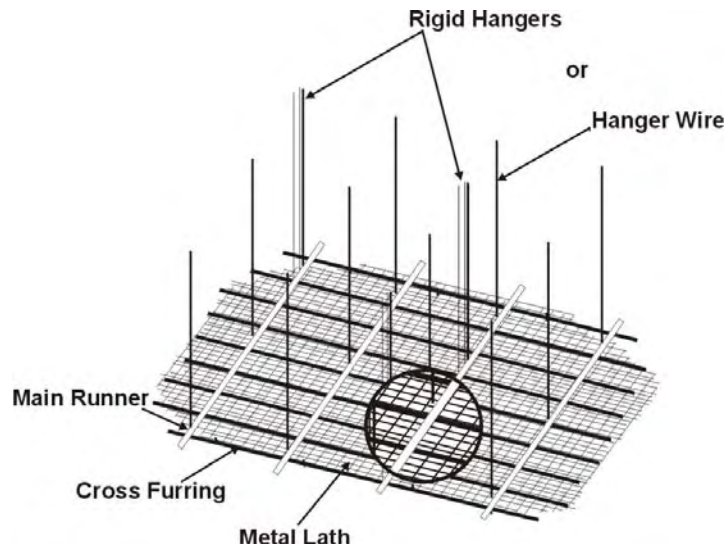

SYNTHETIC PLASTER ON RIGID INSULATION. An exterior wall insulation and finish system (EIFS) consisting of rigid insulation board, reinforcing mesh and a synthetic plaster or stucco coating. Some common trade names are: Dryvit, Insul-Crete, R-Wall, Powerwall, and Sure-Wall.

-T-

TAR-AND-GRAVEL ROOFING. Built-up roofing made up of gravel or sand poured over a heavy coating of coal-tar pitch applied to an underlayer of felt.

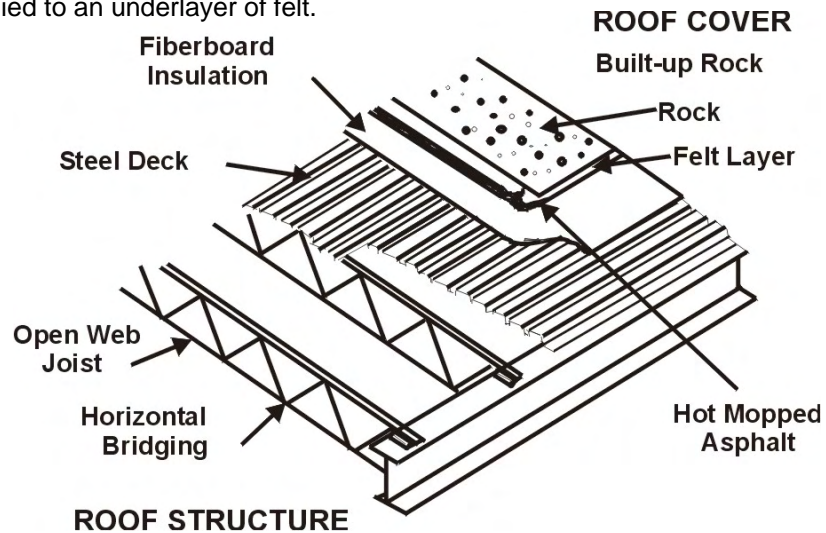

TERNE. Steel sheet coated with lead/tin alloy, used primarily for roofing.

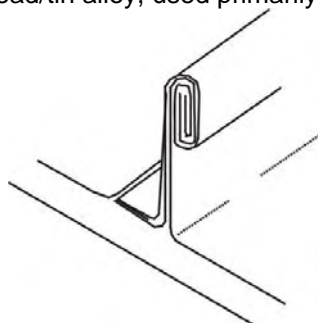

TERRA COTTA. A hard, brown-red, usually unglazed clay product used as an ornamental facing.

TERRAZZO. A durable floor finish made of small chips of colored stone or marble embedded in cement and polished in place to a high glaze.

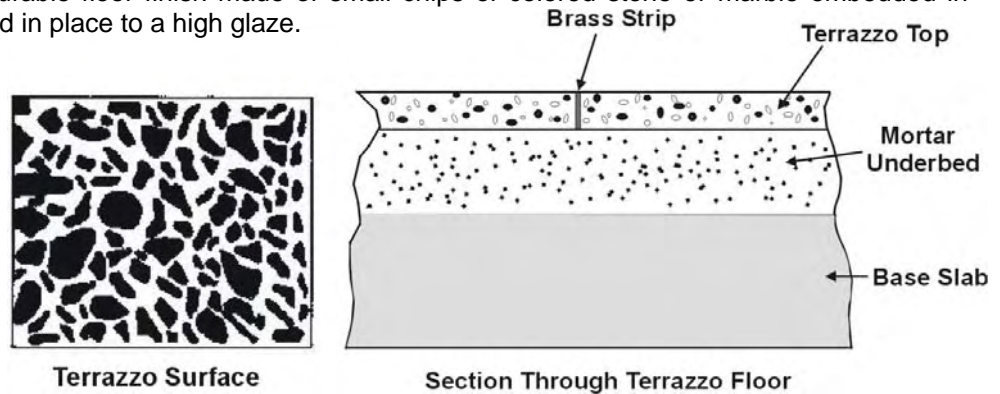

THERMOPANE. Trade name of a double glazed panel for doors or windows used for thermal insulation.

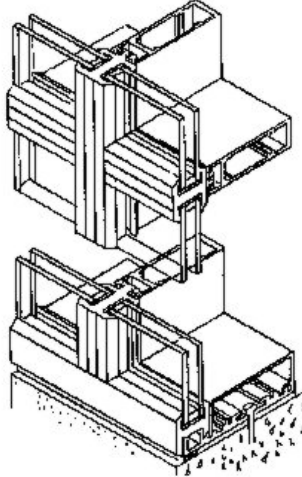

THICKENED-EDGE SLAB. A type of concrete floor slab foundation where the slab is thickened around the edge in lieu of a foundation.

THRU-WALL HEAT PUMP. A small, self-contained heat pump that is designed to be installed in a window opening or wall. Typically there is no ductwork with this unit. Unlike the larger heat pump, it only services one room.

TIE. Wood, rod, chain, which holds two or more structural members together.

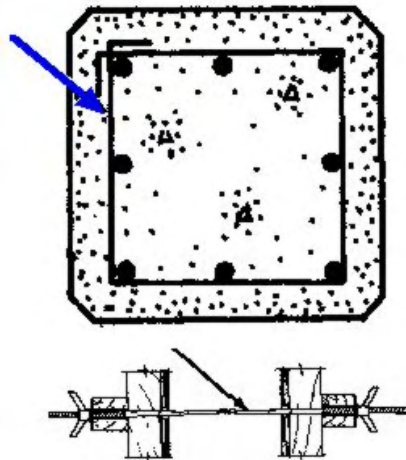

TIE-STALL. Separate stall containing chain or bar onto which a cow's neckstrap is fastened.

TILE. A thin piece of fired clay, stone, or concrete used for roof, floor, or wall finish. A thick piece of resilient material such as cork, asphalt, rubber, or plastic used for floor or wall covering.

TILT-UP CONCRETE PANELS. Concrete wall sections that are cast horizontally and tilted or lifted into building position.

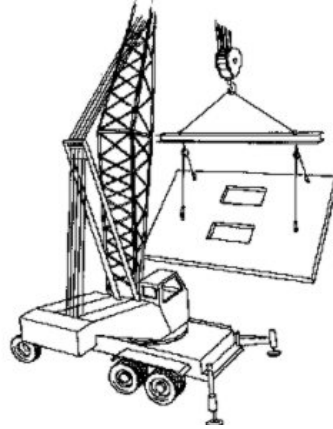

TIP-OUT ROOM. Mobile home extensions; normally smaller than roll-out room; usually has pitched roof.

TONGUE AND GROOVE JOINT. Abbreviated T & G. Any joint made by one member with a projecting tongue fitting into another member with a matching groove.

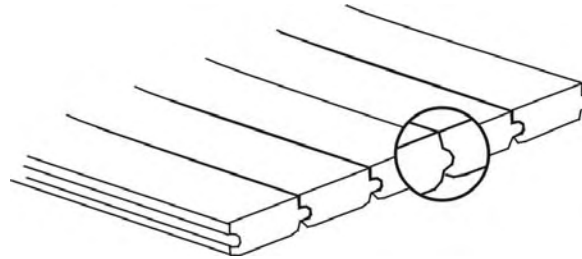

TRACT-BUILT. Many homes built from the same basic plan or plans.

TRANSITE. A trade name commonly used as a general name for a very dense material made from Portland cement and asbestos fibers and used for roofing and siding. It is also used for pipe and electrical conduit.

TREAD. The horizontal part of a step in a staircase.

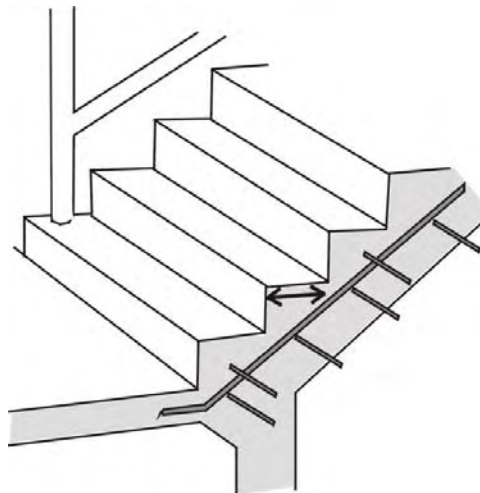

TRIM. Finish materials such as moldings applied around openings, windows, doors, or floors and ceilings (baseboard, cornice, picture molding).

TROWEL FINISH. The surface of concrete finished by smoothing with a trowel (see float finish).

TRUSS. Any of various structural frames based on the geometric rigidity of the triangle and composed of straight members subject only to longitudinal compression and tension; rigid under anticipated loads; spans large area without interior support.

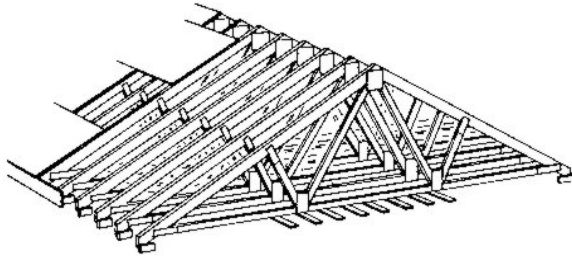

Bowstring



Flat Howe



Belgian Triangular

TRUSSED RAFTER. A truss where the members are serving as rafters and also ceiling joists.

-U-

UNDERLAYMENT. A material that isolates a floor or roof-covering from the deck or subfloor.

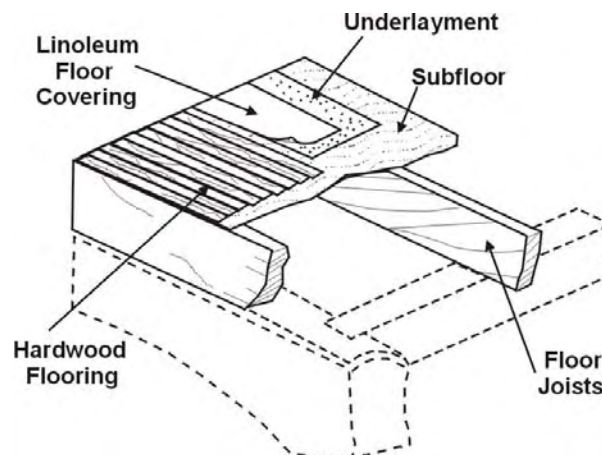

UNDERPINNING. To provide new substructure support beneath a column or a wall, without removing the superstructure, in order to increase the load capacity or return it to its former design limits.

UNIT HEAT - UNIT HEATER. Heat produced by factory-built, gas- or electric-fired assemblies that contain a fan to direct heat to a specific area.

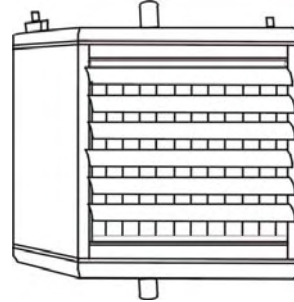

-V-

VALLEY. The place where two planes of a roof meet at a downward, or V angle.

VALUE IN EXCHANGE. The amount of money a property will command in the marketplace.

VALUE IN USE. The amount of money an owner is willing to spend to build or modify real property.

VALLEY RAFTER. Beam immediately under the valley to which jack rafters or purlins connect.

VAPOR BARRIER. Airtight plastic skin used to prevent condensation in walls and floors.

VAULT. A room used for storage of valuable records and/or computer tapes, that is of fire resistive construction, has safe electric components, and has a controlled atmosphere.

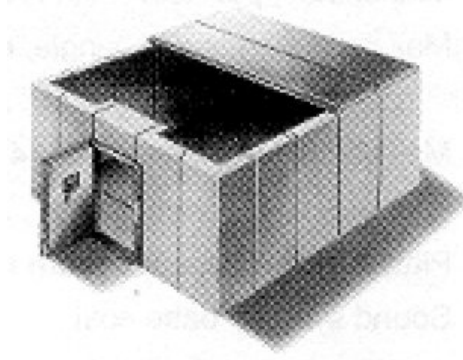

VENEER. A thin surface layer, usually decorative, covering a base of common material.

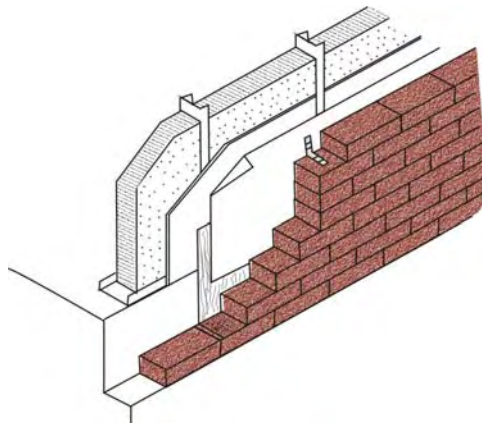

VENEERED WALL. Wall with masonry face attached to, but not bonded to, the body of the wall.

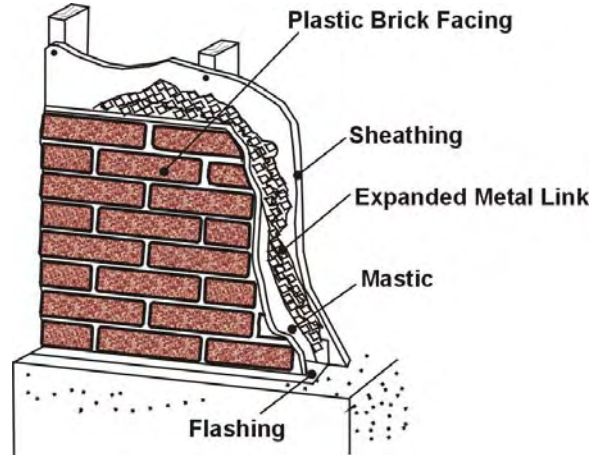

VENT. A small opening serving as an outlet for air.

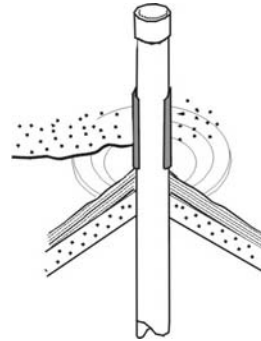

VENTILATION. A natural or mechanical process by which air is introduced to or removed from a space, with or without heating, cooling, or purification treatment.

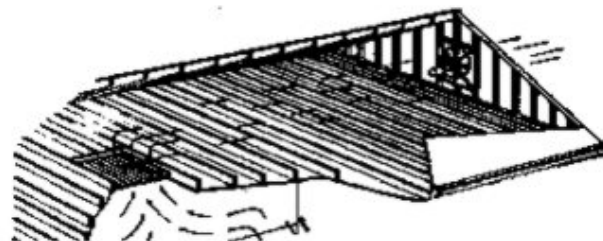
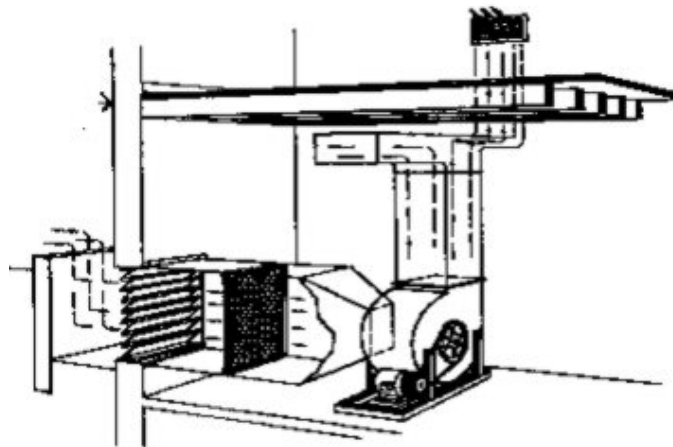

VENTILATION, FAN ONLY

VENTILATOR. Opening or device used to bring in fresh air, and drive out foul air.

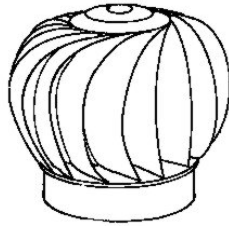

VESTIBULE. A small entrance hall to a building or to a room.

VINYL OR VINYL COMPOSITION TILE. Resilient floor covering made from petroleum derivatives.

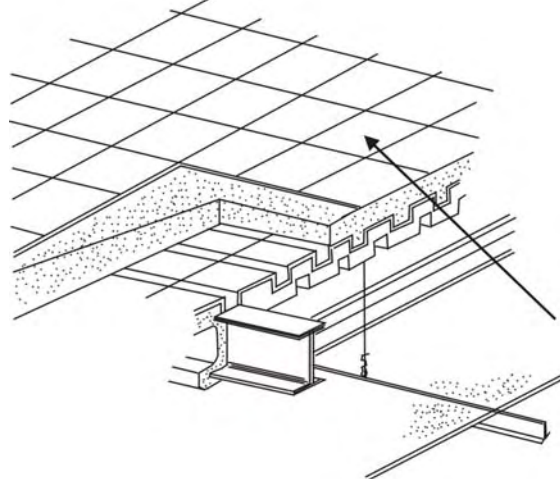

VITRIFIED TILE. A pipe made of clay, baked hard, and then glazed so it is impervious to moisture; used particularly for underground drainage.

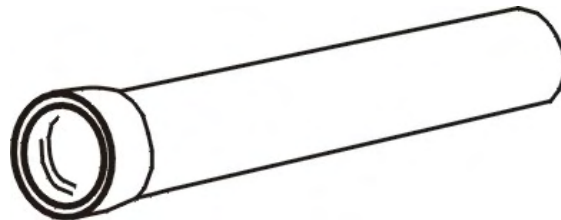

VITROLITE. An opaque structural sheet of glass generally found as a storefront feature.

-W-

WAFFLE FOOTING. A flat reinforced concrete slab foundation with a grid of projections on its lower surface to give additional rigidity. Used when the bearing capacity of the soil is poor or not enough to support a plain flat slab foundation.

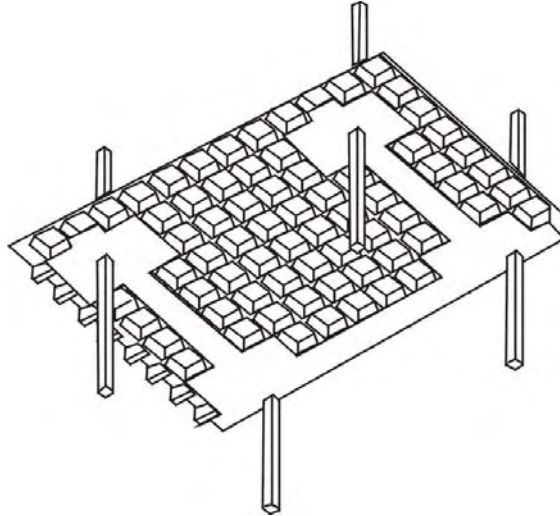

WAINSCOT. Lower part of interior wall when surface finish differs from upper part of wall.

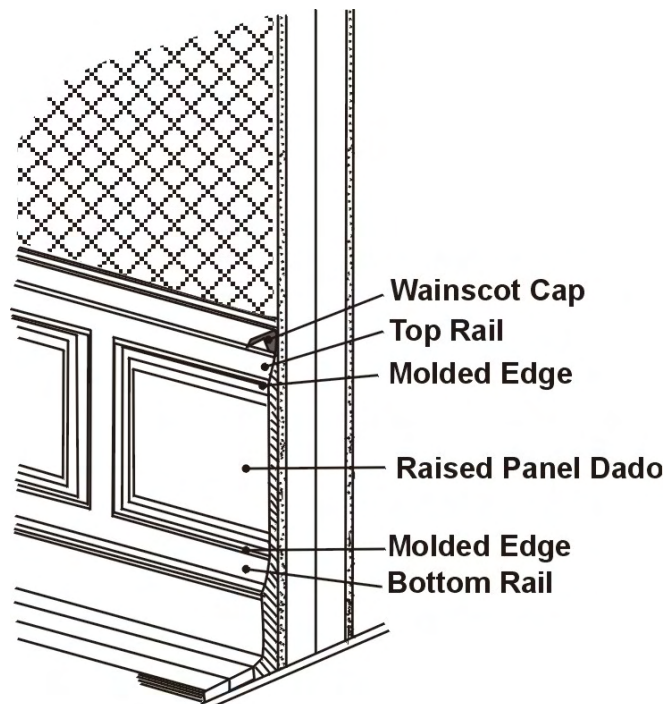

WALK-THROUGH STALL. A stall where the cow enters, holds for milking, and then passes through when finished.

WALL BEARING CONSTRUCTION. A structural system in which the weight of the floor and roof systems is carried directly by the masonry/framed walls.

WALL HEATER. A self-contained heating unit installed in a wall space.

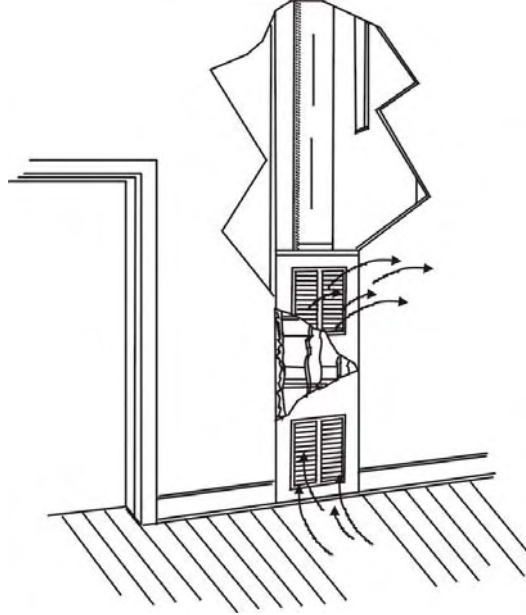

WALLBOARD. A manufactured fibrous compressed material cut into sheets, used for sheathing.

WARM AIR SYSTEM. A heating system in which furnace-heated air moves to living space through a single register or a series of ducts, circulated by natural convection (gravity system), or by a fan or blower in the ductwork (forced system).

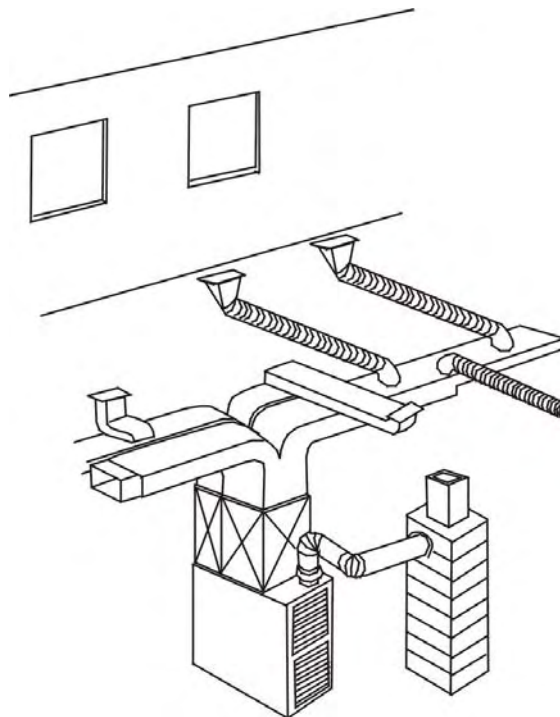

WATER CLOSET. A plumbing fixture used to receive human wastes and flush through a waste pipe. Also called a "flushable toilet."



WATERPROOFING. A procedure to make a material impervious to water or dampness.

WEATHERSTRIP. A thin strip of metal, felt, wood, etc., used to cover the joint between a door or window sash and the jamb, casing, or sill to keep out air, dust, rain, etc.

WEB JOIST. Structural steel framing member made with a web-like pattern.

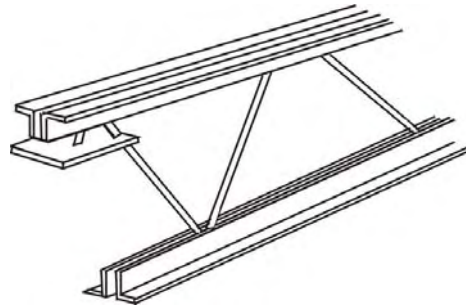

WIND LOAD. The amount of pressure exerted by wind on the exposed surface of a wall or roof, usually expressed in pounds per square foot of surface area.

WINDOW. A glassed opening in a wall or roof for admitting light; usually movable to admit air.

WING. A building section or addition which projects from the main structure.

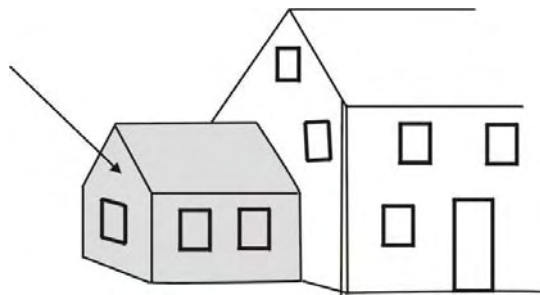

WIRE LATH. A welded-wire mesh used as a base for plaster.

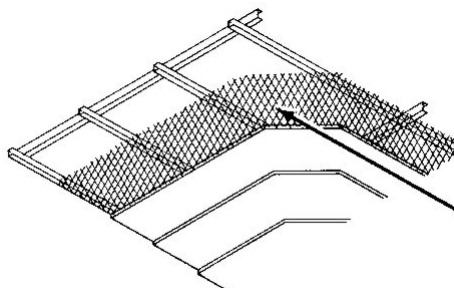

WROUGHT IRON. Soft, pure form of iron easily molded into bars and worked into ornamental shapes; widely used for decorative railings, gates, and panels.

**ARIZONA DEPARTMENT OF REVENUE
CONSTRUCTION COST MANUAL**

**VOLUME II
APPENDIX B
MISCELLANEOUS**

ABBREVIATIONS

Acoustic	Acou.	Horsepower	H.P.	Sliding Door	Sld.Dr.
Addition	Add.	Hundred	C.	Sprinkler	Spr.
Air Conditioning	A.C.	Improvement	Imp.	Square Foot	S.F.
Aluminum	Al.	Inches	In. or "	100 Sq. Feet	Sq.
Asbestos	Asb.	Knotty Pine	K.P.	Square Yards	Sq.Yds
Asphalt	Asp.	Laundry	Ldry	Steel	Stl.
Average	Av.	Lavatory	Lav.	Stucco	Stc.
Basement	Bsmt.	Lineal Foot	Lin.Ft.	Terrace	T.
Barbeque	Bbq.	Linoleum	Lino	Terrazzo	Trzo.
Beam	Bm.	Lump Sum	L.S.	Thermostat	Thermo
Block	Blk.	Masonite	Mas.	Thousand	M.
Board and Batten	B & B	Medium	Med.	Tile	Ti.
Board Measure	B.M.	Metal	Met.	Tongued & Grooved	T.&G.
British Thermal Unit	B.T.U.	On Center	O.C.	Unfinished	Unf.
Carpet	Cpt.	Outside Dimension	O.D.	Urinal	Ur.
Carport	Cp.	Overhead Door	O.H.Dr.	Veneer	Ven.
Celotex	Celo.	Paint	Pt.	Vent thru Roof	V.T.R.
Ceramic Tile	C.T.	Paper	Pa.	Vinyl Composition Tile	V.C.T.
Composition	Comp.	Parquet	Parq.	Wainscot	Wsct.
Concrete	Conc.	Partially Complete	P.C.	Wallboard	W.Bd.
Construction	Constr.	Philippine Mahogany	P.Mha.	Wall Height	W.H.
Corrugated	Corr.	Plaster Board	Pl. Bd.	Wallpaper	W.Pa.
Corrugated Aluminum	Cor.Al.	Plaster & Paint	Pl.&Pt.	Walnut	Wal.
Corrugated Iron	Cor.I.	Plaster & Paper	Pl.&Pa.	Water Closet	W.C.
Cubic Feet	C.F.	Plastic	Plas.	Weatherstrip	Ws.
Cu.Ft. Per Minute	C.F.M.	Plate	Plt.	Wood	Wd.
Cubic Inch	C.I.	Plumbing	Plbg.	1 Story	(1)
Cubic Yards	Cu.Yds	Plywood	Pw.	1" & Basement	(1B)
Diagonal	Diag.	Ponderosa Pine	P.P.	1°"	(1°)
Diameter	Dia.	Porcelain	Porc.	1°" W/Basement	(1°B)
Douglas Fir	D.F.	Porches	P.	2"	(2)
Electric	Elec.	Radiator	Rad.	2" W/Basement	(2B)
Enameled	En.	Redwood	Rdw.	Numeral in circle for more	
Each	Ea.	Reinforced Concrete	Re.Conc.	stories as (3),(6),10)	
Fireplace	Fp.	Residence	Res.		
First Story	1st Sty.	Rock	Rk.	Patio	P
Flagstone	Flag.	Roof Tile	R.T.	Covered Porch, or	
Floor	Fl.	Rubble	Rbl.	Screened-in Porch	O
Formica	Mica.	Rustic, Channel	Chr.Rus.	Glassed-in Porch	G.P.
Frame	Fr.	Rustic, Cove	Cv.Rus.	Enclosed Porch,	
Gable	Gab.	Rustic, V.	V. Rus.	unfinished	CU
Garage	Gar.	Sand Plaster	S.Pl.	Enclosed Porch,	
Glass	Gl.	Sanitas	San.	finished	C.F.
Gravel	Gr.	Second Story	2nd Sty.	Porch Floors	
Gypsum Board	Gyp.Bd.	Shake	Shk.	Concrete Floor	C
Hard Plaster	H.Pl.	Sheathing	Shtg.	Wood Floor	W
Hardwood	H.Wd.	Sheet Vinyl	S.V.	Brick Floor	B
Heavy	Hvy.	Shingle	Shg.	Flagstone Floor	F

AREAS AND MEASURES

To find the circumference of a circle, multiply the diameter by 3.1416. For a partial circumference, divide the circumference by the percentage of the circle present.

To find the diameter, multiply circumference by 0.3183 or divide circumference by 3.1416.

To find the radius, multiply circumference by 0.15915.

To find the side of an inscribed square, multiply the diameter by 0.7071 or multiply the circumference by 0.2251.

To find the side of an equal square, multiply the diameter of its circumscribing circle.

Square. A side multiplied by 4.443 equals the circumference of its circumscribing circle.
 A side multiplied by 1.126 equals the diameter of an equal circle.
 A side multiplied by 3.547 equals circumference of an equal circle.

To find the area of a circle, multiply the circumference by one-quarter of the diameter or multiply the square of the diameter by 0.7854 or multiply the square of the circumference by 0.07958 (or multiply the square of one-half of the diameter by 3.1416). For a partial area, divide the total area by the percentage of circle present.

To find the surface of a sphere or globe, multiply the diameter by the circumference or multiply the square of the diameter by 3.1416 or multiply four times the square of the radius by 3.1416.

To find tank capacities, diameter (in inches) squared x .0034 = gallons per inch of height: Base 42 gallon per barrel.

To find area of a triangle: multiply base by 1/2 perpendicular height.

To find area of an ellipse: product of both diameters x .7854.

To find area of a parallelogram: base x altitude.

Area of rectangle equals length multiplied by width.

Surface of frustum of cone or pyramid: Multiply area of two ends and get square root - add the two areas and times 1/3 altitude.

To find cubic yards of concrete first find volume. Length x width x depth. Example: Find cubic yards of concrete needed for a patio 9 ft. x 18 ft. and 4 inches thick. $9 \times 18 \times .333 = 53.95$ C.F. Since there are 27 cubic feet in 1 cubic yard, divide 53.95 by 27. Answer: 2.0 cubic yards.

WEIGHTS AND MEASURES

1 cu. in. of cast iron weighs		0.26 lbs.
1 cu. in. wrought iron weighs		0.28 lbs.
1 cu. in. water weighs036 lbs.
1 cu. ft. of water weighs		62.208 lbs.
1 United States gallon weighs		8.33 lbs.
1 Imperial gallon weighs		10.00 lbs.
1 United States gallon equals		231.01 cu. in.
1 Imperial gallon equals		277.274 cu. in.
1 cu. ft. of water equals		7.48 U.S. gal.
1 gallon (water)	weighs	8.34 pounds
1 gallon	equals	.1337 cubic feet
1 gallon	equals	.1074 bushels
1 cubic foot	equals	.8032 bushels
1 barrel (oil)	equals	42 gallons
1 barrel (water)	equals	31.5 gallons

AREAS

The square foot area of a surface equals the square of one side multiplied by the factors shown below.

<u>Regular Shaped</u>	<u>Number of Sides</u>	<u>Factor</u>
Equilateral Triangle	3	.433
Pentagon	5	1.721
Hexagon	6	2.598
Heptagon	7	3.634
Octagon	8	4.828
Nonagon	9	6.182
Decagon	10	7.694
Undecagon	11	9.366
Dodecagon	12	1.196

WEIGHTS AND MEASURES**Linear Measure**

12 Inches = 1 Foot
 3 Feet = 1 Yard
 16 Feet = 1 Rod
 40 Rods = 1 Furlong
 8 Furlongs = 1 Mile

Square Measure

144 Square Inches = 1 Square Foot
 9 Square Feet = 1 Square Yard
 100 Square Feet = 1 Square
 30 Square Yards = 1 Square Rod
 160 Square Rods = 1 Square Acre
 640 Acres = 1 Square Mile
 43,560 Square Feet = 1 Acre

Cubic Measure

1,728 cubic in. = 1 cu. ft.
 27 cubic ft. = 1 cu. yd.
 128 cubic ft. = 1 cord

Gunther's Chain

1 Link = 7.92 Inches = .01 Chain = .000125 Mile
 1 Chain = 100 Links = 66 Feet = 4 Rods = .0125 Mile
 1 Mile = 80 Chains = 8000 Links

METRIC SYSTEM**Length**

Unit	Abbreviation	Number of Meters	Approximate U.S. Equivalent
myriameter	mym	10,000	6.2 miles
kilometer	km	1,000	0.62 miles
hectometer	hm	100	328.08 feet
dekameter	dam	10	32.81 feet
meter	m	1	39.37 inches
decimeter	dm	0.1	3.94 inches
centimeter	cm	0.01	.39 inches
millimeter	mm	0.001	0.04 inches

U.S. SYSTEM**Area**

Unit	Abbreviation	Equivalents in Other Units of Same System	Metric Equivalent
square mile	sq. mi.	640 acres	2,590 square kilometers
acre		43,560 square feet	4,047 square meters
square foot	sq.ft.	144 square inches	0.093 square meters

WEIGHTS AND MEASURES

Steel Weights

Channels Standard

<u>Width</u>	<u>Depth</u>	Lbs. per <u>Lin. Ft.</u>
1"	3"	4.0
1-5/8"	4"	5.4
1-3/4"	5"	6.7
2"	6"	8.2
2-1/8"	7"	9.8
2_ "	8"	11.5
2-1/2"	9"	13.4
2-5/8"	10"	15.3
3"	12"	20.7
3-3/8"	15"	33.9
4"	18"	45.8

H Columns

<u>Depth</u>	<u>Width</u>	Lbs. per <u>Lin. Ft.</u>
4"	4"	14.0
5-1/8"	x 5"	18.5
6	x 6"	24.0
8-1/8"	x 8"	35.0
10	x 10"	49.0
12-1/2"	x 12"	65.0
14-1/2"	x 14"	87.0

I Beams

<u>Depth</u>	<u>Width</u>	Lbs. Per <u>Lin. Ft.</u>
3	2-1/2	7.5
4	2-3/4	9.5
5	3-1/4	14.75
6	3-5/8	17.25
7	3-3/4	17.5
8	4-1/8	23.0
10	5	35.0
12	5-1/2	50.0
15	6-1/8	65.0
18	6-1/4	70.0
20	7-1/8	90.0
24	8	115.0

Structural Angles

Size in <u>Inches</u>	Lbs. per <u>Lin. Ft.</u>
3x2x3/16	3.07
3x2x1/4	4.1
3x2x1/2x1/4	4.5
3x2-1/2x5/16	5.6
3x3x3/16	3.71
3x3x1/4	4.9
3x3X1/2	9.4
3-1/2x2-1/2x1/4	4.9
3-1/2x2-1/2x3/8	7.2
3-1/2x3-1/2x1/4	5.8
4x3x1/4	5.8
4x4x1/4	6.6
5x3x1/4	6.6
5x5x3/8	12.3
6x4x5/16	10.3
6x4x3/8	12.3
6x6x3/8	14.9

Wide Flange Beams

Size in <u>Inches</u>	Lbs. per <u>Lin. Ft.</u>
6x4	12
8x4	15
8x5-1/4	17
8x6-1/2	24
8x8	35
10x4	17
10x5-3/4	25
10x8	39
12x4	19
12x6-1/2	31
12x8	45
14x8	43
16x7	50
21x8-1/4	68
24x9	76

Plate Steel

12" x 12" x 1" -40.8 lbs.

WEIGHTS AND MEASURES**Metals**

Weights per Square Foot

Thickness	Wrought	Cast	Steel	Copper	Brass	Lead	Zinc
	Iron	Iron					
	lbs	lbs	lbs	lbs	lbs	lbs	lbs
1/16	2.15	2.34	2.55	2.89	2.67	3.69	2.34
1/8"	5.03	4.69	5.10	5.78	5.35	7.38	4.68
3/16"	7.58	7.03	7.66	8.67	8.02	11.07	7.02
1/4"	10.07	9.38	10.21	11.56	10.7	14.76	9.36
5/16"	12.58	11.73	12.71	14.45	13.37	18.45	11.7
3/8"	15.10	14.07	15.31	17.34	16.05	22.14	14.04
7/16"	17.62	16.42	17.87	20.23	18.72	25.83	15.34
1/2"	20.14	18.77	20.42	23.12	21.4	29.53	18.72
9/16"	22.65	21.11	22.97	26.01	23.07	33.22	21.08
5/8"	25.17	23.46	25.52	28.90	26.75	36.91	23.44
11/16"	27.69	25.81	28.08	31.97	29.42	40.60	25.80
3/4"	30.21	28.15	30.63	34.68	32.1	44.29	28.13
13/16"	32.72	30.50	33.18	37.57	35.19	47.98	30.49
7/8"	35.24	32.85	35.73	40.69	38.28	51.67	32.81
15/16"	37.76	35.19	38.28	43.35	41.37	55.37	35.17
1"	40.28	37.54	40.83	46.25	43.75	59.06	37.50

To convert bushels to tons, multiply number of bushels by 60 and divide the produce by 2,000 (avg. maximum weight of commodities 60 pounds per bushel).

To convert gallons to bushels, divide gallons by 9.35. Answer in bushels.

To convert cubic feet measure into bushels, multiply by 0.8035.

To find capacity of cylindrical tanks standing on end: To find the capacity in cubic feet of round tank or cistern, multiply the square of the average diameter by the depth, and multiply the product by .785.

WEIGHTS AND MEASURES

A gallon of water (U.S. Standard) weighs 8-1/3 pounds and contains 231 cubic inches.

A cubic foot of water contains 7° gallons, 1,728 cubic inches, and weighs 62° pounds.

Doubling the diameter of a pipe increases its capacity four times.

To find the capacity of tanks any size in U. S. gallons, given the dimension of a cylinder in inches: square the diameter, multiply by the length (all in inches) and by .0034. (Note: See table on tank capacities.)

Rectangular tanks: multiply the length by the width by the depth (all in inches) and divide the result by 231. The answer is the capacity in gallons.

31° gallons equals 1 barrel (water).

B.T.U. (British Thermal Unit) is the amount of heat required to raise one pound of water one degree Fahrenheit.

A ton of refrigeration is measured by the displacement of the amount of heat required to melt a ton of ice in 24 hours. One motor horsepower of an electrically powered unit is normally required to produce one ton of refrigeration. 12,000B. equals one ton.

Kilowatts multiplied by 1.3405 equal horsepower.

Kilowatts equal .746 multiplied by the horsepower.

Brick - Common bricks of the national size weigh from 4° to 5 lbs; pressed and paving, from 6 to 7, depending upon clay, burning, and size.

Lime - On the basis of 53 lbs. to the cu. ft., lime weighs about 66 lbs. to the bushel, but in bulk it is often sold on the basis of 80 lbs. to 200 lbs. to the bbl of 2 1/4 bushels.

TABLES
**For Area and Content Capacity Computations
Capacity of Circular Tanks; Per Foot of Height in Gallons & Bushels**

Diameter In Feet	Circumference	Square Ft. Area	Gallons	Bushels	Barrels (Oil) (42 gal. ea.)
3	9.42	7.07	53	6	1.26
4	12.57	12.57	94	10	2.24
5	15.71	19.64	147	16	3.5
6	18.85	28.27	212	23	5.02
7	21.99	38.48	288	31	6.86
8	25.13	50.27	376	40	8.95
9	28.27	63.62	476	51	11.33
10	31.42	78.54	587	63	13.98
11	34.56	95.03	711	76	16.93
12	37.70	113.10	846	91	20.2
13	40.84	132.73	993	106	23.64
14	43.98	153.94	1,151	123	27.40
15	47.12	176.72	1,322	141	31.48
16	50.27	201.06	1,504	161	35.81
17	53.41	226.98	1,698	182	40.43
18	56.55	254.47	1,903	204	45.31
19	59.69	283.53	2,121	227	50.50
20	62.83	314.16	2,350	251	55.95
21	65.97	346.36	2,591	277	61.69
22	69.12	380.13	2,843	304	67.69
23	72.26	415.48	3,108	332	74.00
24	75.40	452.39	3,384	362	80.57
25	78.54	490.88	3,672	393	87.43
26	81.68	530.93	3,971	425	94.55
27	84.82	572.56	4,283	458	101.98
28	87.96	615.75	4,606	493	109.67
29	91.11	660.52	4,941	528	117.64
30	94.25	706.86	5,287	565	125.88
31	97.39	754.77	5,646	604	134.43
32	100.53	804.25	6,016	643	143.24
33	103.67	855.30	6,398	684	152.33
34	106.81	907.92	6,791	726	161.69
35	109.96	962.12	7,197	770	171.36

TABLES

For Area and Content Capacity Computations
Capacity of Circular Tanks; Per Foot of Height in Gallons & Bushels

Diameter In Feet	Circumference	Square Ft. Area	Gallons	Bushels	Barrels (Oil) (42 gal. ea.)
36	113.10	1,017.88	7,614	814	181.29
37	116.24	1,075.21	8,043	860	191.50
38	119.38	1,134.12	8,483	907	201.98
39	122.52	1,194.59	8,936	956	212.76
40	125.66	1,256.64	9,400	1,005	223.81
41	128.81	1,320.26	9,876	1,056	235.14
42	131.95	1,385.45	10,363	1,108	246.74
43	135.09	1,452.20	10,863	1,162	258.64
44	138.23	1,520.53	11,374	1,216	270.81
45	141.37	1,590.44	11,896	1,272	283.24
46	144.51	1,661.91	12,431	1,330	295.98
47	147.66	1,734.95	12,977	1,388	308.98
48	150.80	1,809.56	13,536	1,448	322.29
49	153.94	1,885.75	14,105	1,509	335.83
50	157.08	1,963.50	14,687	1,571	349.69
51	160.22	2,042.83	15,280	1,634	363.81
52	163.36	2,123.72	15,885	1,699	378.21
53	166.50	2,206.19	16,502	1,765	392.90
54	169.65	2,290.23	17,131	1,832	407.88
55	172.79	2,375.84	17,771	1,901	423.12
56	175.93	2,463.01	18,423	1,970	438.64
57	179.07	2,551.76	19,087	2,041	454.45
58	182.21	2,642.09	19,763	2,114	470.55
59	185.35	2,733.98	20,450	2,187	486.90
60	188.50	2,827.44	21,149	2,262	503.55
61	191.64	2,922.47	21,860	2,338	520.48
62	194.78	3,019.08	22,583	2,415	537.69
63	197.92	3,117.25	23,317	2,494	555.17
64	201.06	3,217.00	24,063	2,574	572.93
65	204.20	3,318.32	24,821	2,655	590.98
66	207.35	3,421.20	25,591	2,737	609.31
67	210.49	3,525.66	26,372	2,821	627.90
68	213.63	3,631.69	27,165	2,905	646.79
69	216.77	3,739.29	27,970	2,991	665.95
70	219.91	3,848.46	28,787	3,079	685.40
71	223.05	3,959.20	29,615	3,167	705.12

TABLES

For Use in Area and Content Capacity Computations
Capacity of Circular Tanks; Per Foot of Height in Gallons & Bushels

Diameter In Feet	Circumference	Square Ft. Area	Gallons	Bushels	Barrels (Oil) (42 gal. ea.)
72	226.20	4,071.51	30,455	3,257	725.12
73	229.34	4,185.40	31,307	3,348	745.40
74	232.48	4,300.85	32,170	3,441	765.95
75	235.62	4,417.88	33,046	3,534	786.81
76	238.76	4,536.47	33,933	3,629	807.93
77	241.90	4,656.64	34,832	3,725	829.33
78	245.04	4,778.37	35,742	3,823	851.00
79	248.19	4,901.68	36,665	3,921	872.98
80	251.33	5,026.56	37,599	4,021	895.21
81	254.47	5,153.01	38,545	4,122	917.74
82	257.61	5,281.03	39,502	4,225	940.52
83	260.75	5,410.62	40,471	4,328	963.60
84	263.89	5,541.78	41,453	4,433	986.98
85	267.04	5,674.52	42,445	4,540	1,010.60
86	270.18	5,808.82	43,450	4,647	1,034.52
87	273.32	5,944.69	44,466	4,756	1,058.71
88	276.46	6,082.14	45,494	4,866	1,083.19
89	279.60	6,221.15	46,534	4,977	1,107.95
90	282.74	6,361.74	47,586	5,089	1,133.00
91	285.89	6,503.90	48,649	5,203	1,158.31
92	289.03	6,647.63	49,724	5,318	1,183.90
93	292.17	6,792.92	50,811	5,434	1,209.79
94	295.31	6,939.79	51,910	5,552	1,235.95
95	298.45	7,088.24	53,020	5,671	1,262.38
96	301.59	7,238.25	54,142	5,791	1,289.10
97	304.74	7,389.83	55,276	5,912	1,316.10
98	307.88	7,542.98	56,422	6,034	1,343.38
99	311.02	7,697.71	57,579	6,158	1,370.93
100	314.16	7,854.00	58,748	6,283	1,398.76

To find the capacity in gallons = Dia. squared x 5.8748 x height (diameter & height in feet).