



TASK ASSIGNMENT MPD 32-10  
FINAL REPORT  
**Doney Park**

MULTIMODAL TRANSPORTATION STUDY



**NOVEMBER 2011 | PREPARED FOR:**  
Coconino County Community Development  
Coconino County Public Works Department  
Arizona Department of Transportation



← Flagstaff  
Page →  
← →  
**PREPARED BY:**  
  
Kimley-Horn  
and Associates, Inc.



**ADOT**

# Doney Park Multimodal Transportation Study

ADOT MPD Task Assignment 32-10

---

## Final Report

*Prepared by:*



Kimley-Horn  
and Associates, Inc.

*Prepared for:*

ARIZONA DEPARTMENT OF TRANSPORTATION  
COCONINO COUNTY COMMUNITY DEVELOPMENT  
COCONINO COUNTY PUBLIC WORKS DEPARTMENT

November 2011  
091374038

---



**TABLE OF CONTENTS**

**INTRODUCTION .....1**

1.1 Study Purpose..... 1

1.2 Study Objectives..... 1

1.3 Study Area..... 2

1.4 Doney Park Residents Value a Rural Lifestyle..... 2

1.5 Doney Park Timberline Fernwood Area Plan..... 2

1.6 Schultz Fire/Flood Relationship to Multimodal Planning..... 3

**2 CURRENT AND FUTURE CONDITIONS .....5**

2.1 Land Use..... 5

2.2 Activity Centers..... 5

2.3 Streets and Roadways..... 6

    2.3.1 Traffic Data..... 6

    2.3.2 Crashes..... 7

    2.3.3 Roadway Winter Maintenance Practices..... 10

2.4 Pedestrian and Bicycle Facilities..... 11

    2.4.1 Existing Pedestrian Paths and Sidewalks..... 11

    2.4.2 Existing Trails..... 12

    2.4.3 Proposed Trails and Off-Street Facilities..... 13

**3 STAKEHOLDER AND PUBLIC INPUT .....17**

3.1 Stakeholder Interviews..... 17

3.2 Public Open Houses..... 17

3.3 Stakeholder and Public Input Findings..... 17

**4 PROPOSED PROJECTS .....18**

4.1 Roadway Connectivity..... 18

4.2 Shared-Use Paths..... 18

    4.2.1 Cautions for Shared-Use Paths Adjacent to Roadways..... 20

    4.2.2 Shared Use Path Courtesy..... 20

    4.2.3 Paved Surface Shared-Use Path..... 21

    4.2.4 Soft Surface Path for Equestrians and Pedestrians..... 24

4.3 Sidewalks..... 26

4.4 Paved Shoulders..... 26



4.5	Bicycle Lanes and Bicycle Route Signage.....	27
4.6	Shoulder Maintenance and Sweeping.....	28
4.7	Detailed Project Descriptions.....	28
4.8	Project Phasing.....	29
4.8.1	<i>Phase I Projects</i> .....	29
4.8.2	<i>Phase II Projects</i> .....	29
4.8.3	<i>Phase III Projects</i> .....	29
4.9	Transit Service .....	36
<b>5</b>	<b>IMPLEMENTATION REVENUE SOURCES .....</b>	<b>38</b>
5.1	Transportation Enhancement (TE) Grant Funding.....	38
5.2	Safe Routes to School Program .....	38
5.3	Use of Federal Funds for Equestrian Trails .....	39
5.4	Coconino Parks and Open Space Program .....	39
5.5	Federal Recreational Trails Program .....	39
5.6	National Park Service Rivers, Trails, and Conservation Assistance Program .....	40
<b>6</b>	<b>MAINTENANCE .....</b>	<b>41</b>
6.1	Maintenance Activities.....	41
6.2	Maintenance Costs .....	42
	<b>APPENDIX A – PROJECT INFORMATION SHEETS .....</b>	<b>43</b>



**INDEX OF FIGURES**

Figure 1 – Study Area ..... 4  
 Figure 2 – Road System Map ..... 8  
 Figure 3 – Existing and Proposed Trails ..... 16  
 Figure 4 – Proposed Projects ..... 19  
 Figure 5 – Shared-Use Path: Paved Path with Equestrian Path ..... 22  
 Figure 6 – Shared-Use path: Paved Path with Equestrian Path and Bicycle Lane ..... 23  
 Figure 7 – Paved Shared-Use Path Typical Sections ..... 24  
 Figure 8 – Soft Surface Equestrian and Pedestrian Path ..... 25  
 Figure 9 – Transit Alternatives ..... 37

**INDEX OF TABLES**

Table 1 – Maximum Daily Volume Thresholds for LOS C, D, and E ..... 9  
 Table 2 – Existing and Future Daily Traffic Volumes on US 89 ..... 9  
 Table 3 – Existing and Future Daily Traffic Volumes on Study Area Roadways ..... 9  
 Table 4 – Pedestrian Facilities ..... 11  
 Table 5 – Study Area Trails ..... 14  
 Table 6 – Paved Shared-Use Path Features ..... 24  
 Table 7 – Soft Surface Equestrian and Pedestrian Path Features ..... 26  
 Table 8 – Phase 1 Recommended Projects ..... 30  
 Table 9 – Phase 2 Recommended Projects ..... 32  
 Table 10 – Phase 3 Recommended Projects ..... 34  
 Table 11 – Summary of Costs by Phase ..... 35

**INDEX OF PROJECT INFORMATION SHEETS**

Project Information Sheet 1 – Burris Lane 1 ..... 44  
 Project Information Sheet 2 – Burris-2 ..... 45  
 Project Information Sheet 3 – Burris-3 ..... 46  
 Project Information Sheet 4 – Campbell-1 ..... 47  
 Project Information Sheet 5 – Campbell - 2 ..... 48  
 Project Information Sheet 6 – Cosnino-1 ..... 49  
 Project Information Sheet 7 – Cosnino-2 ..... 50  
 Project Information Sheet 8 – Cosnino-3 ..... 51  
 Project Information Sheet 9 – Koch Field-1 ..... 52  
 Project Information Sheet 10 – Koch Field-2 ..... 53  
 Project Information Sheet 11 – Leupp-1 ..... 54  
 Project Information Sheet 12 – Neptune-1 ..... 55  
 Project Information Sheet 13 – Neptune-2 ..... 56  
 Project Information Sheet 14 – Neptune-3 ..... 57



Project Information Sheet 15 – Picture Canyon Trail.....	58
Project Information Sheet 16 – Rio Rancho-1 .....	59
Project Information Sheet 17 – Silver Saddle-1 .....	60
Project Information Sheet 18 – Silver Saddle-2 .....	61
Project Information Sheet 19 – Skeet-1 .....	62
Project Information Sheet 20 – Slayton Ranch-1 .....	63
Project Information Sheet 21 – Slayton Ranch-2 .....	64
Project Information Sheet 22 – Slayton Ranch-3 .....	65
Project Information Sheet 23 – Stardust-1 .....	66
Project Information Sheet 24 – Stardust-2.....	67
Project Information Sheet 25 – Townsend-Winona-1 .....	68
Project Information Sheet 26 – Townsend-Winona-2 .....	69
Project Information Sheet 27 – Townsend-Winona-3 .....	70
Project Information Sheet 28 – Townsend-Winona-4 .....	71
Project Information Sheet 29 – Townsend-Winona-5 .....	72
Project Information Sheet 30 – US 89-1 .....	73
Project Information Sheet 31 – US 89-2.....	74
Project Information Sheet 32 – US 89-3.....	75
Project Information Sheet 33 – US89-4.....	76
Project Information Sheet 34 – US 89-5.....	77
Project Information Sheet 35 – US 89-6.....	78
Project Information Sheet 36 – Yancey-1.....	79
Project Information Sheet 37 – Transit-1.....	80
Project Information Sheet 38 – Transit-2.....	80
Project Information Sheet 39 – Transit-3.....	81



## INTRODUCTION

The Arizona Department of Transportation (ADOT), through the Planning Assistance for Rural Areas (PARA) program, awarded funding to Coconino County for the Doney Park Multimodal Transportation Study. The Study will identify needs and deficiencies for multimodal travel within Doney Park and will recommend a program of projects to address multimodal transportation needs. The Study will serve as a guide for community development, project funding applications, and project implementation.

It is important to emphasize that the projects recommended in this study may be constructed incrementally over a considerable period of time as opportunities arise and funding becomes available. Projects may be initiated at any time after completion of the study, and full implementation of all the projects may not occur for 10 to 20 years or longer. There is no guarantee that all projects will be completed and some may be eliminated from consideration due to lack of funding or other unforeseen circumstances.

### 1.1 Study Purpose

The Study will identify a program of projects that upon implementation will improve multimodal travel in Doney Park. This will be accomplished through completion of the following:

- Document current and future conditions relating to multimodal transportation (pedestrian, bicycle, equestrian, and transit) throughout Doney Park. Identify key activity centers.
- Identify and summarize multimodal needs and deficiencies; review and confirm needs and deficiencies as identified in the *Doney Park Timberline Fernwood Area Plan* (2001).
- Recommend a program of projects that upon implementation will improve multimodal travel in Doney Park. The program of improvements will provide Coconino County with a planning document that can be used to help secure funding for implementation of the multimodal improvements.

### 1.2 Study Objectives

Objectives of the Doney Park Multimodal Transportation Study are:

1. Identify and document multimodal safety needs for bicyclists, pedestrians, equestrians, and transit users.
2. Evaluate existing and needed on-street multimodal accommodations.
3. Identify off-street pathway opportunities.
4. Identify activity centers and connectivity to the activity centers.
5. Improve connectivity to transit facilities.
6. Identify other roadway and safety improvements required to improve overall multimodal travel in Doney Park.
7. Review winter roadway maintenance practices.
8. Develop a guidance document for implementation.



### **1.3 Study Area**

Doney Park, located northeast of Flagstaff, Arizona, is an unincorporated community of approximately 8,000 residents. The study area for the Doney Park Multimodal Transportation Study (**Figure 1**) is the same as that of the *Doney Park Timberline Fernwood Area Plan* (2001) and encompasses an area of approximately 62 square miles. The area extends from Camp Townsend just north of the Flagstaff city limits at the southwest corner to Lenox Park at the northwest corner. The area extends east to Winona.

Major roadways in the study area include:

- US 89, Flagstaff city limits (MP 420.38) to north of Lenox Road, at approximately MP 429.3
- Townsend-Winona Road, from US 89 to I-40
- Leupp Road, from Townsend-Winona Road to approximately three miles north of Townsend-Winona Road
- I-40, from Flagstaff city limits to east of Townsend-Winona Road (MP 205.5 to 211.5)

The study area for the Doney Park Multimodal Transportation Study is depicted in **Figure 1**.

### **1.4 Doney Park Residents Value a Rural Lifestyle**

Many who live in the Doney Park area value a rural lifestyle and environment. They enjoy convenient access to open space, and recreational opportunities. During plan development, many expressed concern that pathways and bicycle lanes would detract from a rural environment. Many others expressed strong support for the improvements. As concisely and clearly explained by a study stakeholder,

“Proper planning for multimodal transportation is not counter to rural values. The ability to travel on foot, bicycle or horse is part of a long standing rural tradition in our country. Providing pathways to allow the safe and desirable use of foot, bicycle or horse is just good responsible community planning.”

### **1.5 Doney Park Timberline Fernwood Area Plan**

Recommendations of the Doney Park Multimodal Transportation Study build upon concepts originally proposed in the *Doney Park Timberline Fernwood Area Plan*. A goal of the *Doney Park Timberline Fernwood Area Plan* (Plan) is to provide a non-motorized trail system to provide access between neighborhoods and schools, public lands, and other trail systems. The plan also has 12 policies with respect to trails and alternative transportation.

The Plan has the following policy to establish the following non-motorized trails:

- Trails along existing and proposed collector streets;
- A trail along the Rio de Flag and links to the city FUTS trails as depicted in the Open Spaces & Greenways Plan;
- Non-motorized Pedestrian/Bicycle/Equestrian trails along arterial roads (Highway 89 and Townsend Winona Road);





- Non-motorized loop trails in the Old Caves Crater area and the cinder hill between Slayton Ranch Road and Stardust Trail. Identify and implement additional loop trails in appropriate areas;
- Trail linkages between Timberline-Fernwood and the Koch Field area from the east side of Highway 89 (providing access to the Peaks View Park);
- Trail linkages between the north and east sides of Doney Park to proposed Townsend-Winona Road corridor in the Open Spaces and Greenways Plan;
- Continuation of the proposed trail corridor in the Open Spaces & Greenways Plan that dead ends in Winona to loop back to an existing or proposed trail;
- A trail over Crisp Hill from east to west; and
- A connection from Eagle and Atkinson to the north end of Copeland/Tanager.

The Doney Park Multimodal Transportation Study serves to advance many of these concepts. In particular, as outlined in Chapter 4, the Doney Park Multimodal Transportation Study proposes a network of pathways along collectors and arterials, including along US 89. Bicycle lanes and paved shoulders are proposed along major arterials. Equestrian and pedestrian paths are proposed along several collector streets in the Doney Park area. Equestrian paths provide connections to adjacent U.S. Forest Service lands.

## **1.6 Schultz Fire/Flood Relationship to Multimodal Planning**

Shortly after the Doney Park Multimodal Transportation Study was initiated in June, 2010, a devastating wildfire broke out in the Schultz Pass area that ultimately burned more than 15,000 acres of Coconino National Forest land on the east side of the San Francisco Peaks. The burn area is on steep slopes above the Timberline and Wupatki Trails portions of the study area west of Highway 89. With most of the vegetation on the mountainside burned, the community below the burn has become susceptible to severe flooding.

Planning for flood mitigation projects commenced immediately following the fire and will continue to evolve over a considerable time period. During the study, questions have been raised about how flood mitigation planning relates to multimodal transportation planning and vice versa. The short answer is that protection of life and property obviously takes precedence over amenities such as shared-use pathways and other multimodal improvements. However, there may be opportunities to develop dual-purpose facilities that accomplish flood mitigation and multimodal improvements concurrently by incorporating such improvements into flood control channels, berms, or basins.

At the time this study is being written, flood mitigation planning has not advanced sufficiently to incorporate specific recommendations for dual-purpose facilities; as such, project-specific recommendations are not included in this study. As flood mitigation projects become more specific, planning and management teams will look for opportunities to incorporate multimodal improvements where feasible and cost effective.

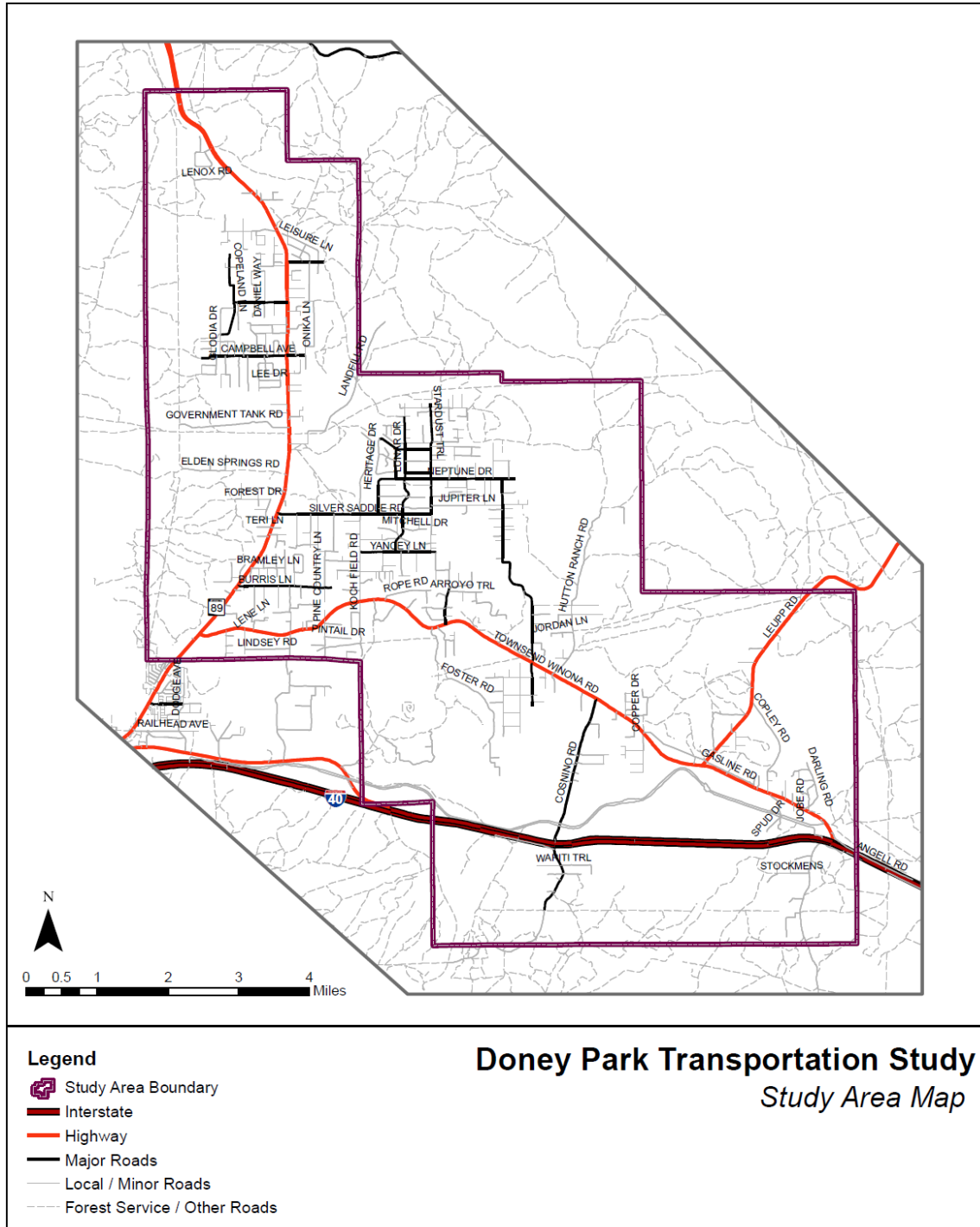

**Figure 1 – Study Area**



## 2 CURRENT AND FUTURE CONDITIONS

This chapter summarizes data obtained on current and planned conditions to help identify needs and deficiencies for the transportation network.

### 2.1 Land Use

The predominant land use in the privately owned sections of the study area is residential. The residential areas are generally low density, and range from one unit per ten acres south of I-40 at Winona to nine units per acre in the Elden Shadows Mobile Home Community (formerly the Wheel Inn Mobile Home Park). The majority of the area is zoned Agricultural Residential with a 2 ½ acre minimum parcel size. The Forest Survey Tracts and an area north of Copeland and mostly west of Highway 89 are zoned Agricultural Residential and are developed with five-acre lots (AR-5). A large portion of the remainder of the study area is also zoned AR-5, but is mostly Forest Service land.

Commercial land use is zoned primarily at major intersections. Commercial land uses are located at Camp Townsend on both sides of US 89, on Highway 89 near Burriss Lane, Silver Saddle Road, Campbell Avenue, and Copeland Lane. Commercial land uses are also located at the intersection of Townsend-Winona and Lumberjack, and at I-40/Winona.

The *Doney Park Timberline Fernwood Area Plan* estimated there were (as of January 2000) 3,380 lots or parcels in the area of which an estimated 90% were developed. Given existing zoning, it was estimated that the remaining vacant land could be divided into an additional 1,456 parcels. In 2000, it was estimated that should trends continue, buildout would occur between 2015 and 2020, although with economic recession that began in 2008, buildout may not occur as soon as estimated.

### 2.2 Activity Centers

A primary objective of the multimodal program of improvements is to connect activity centers. Doney Park activity centers, and how the program of projects serves to connect them, are shown in **Figure 4**. Doney Park area activity centers include:

1. **Parks:** Peaks View County Park is located at 8805 North Koch Field Road. This park features sports fields, hiking and equestrian trails, a playground, and a picnic area. The park is adjacent to Cromer Elementary School and is just south of the Summit Fire Station.
2. **Schools:** Cromer Elementary School is located at 7150 E. Silver Saddle Road. This school is attended by approximately 600 students.
3. **Fire Stations:** Summit Fire Stations are located at 8905 Koch Field Road, 6050 E. Firehouse Lane, and 6425 N. Cosnino Road. Meetings and community events are held at the fire stations.
4. **Trailheads:** Coconino National Forest trailheads within the study area are activity centers, as they attract recreational trips.



- Sandy Seep Trail trailhead, accessed from US 89, one-half mile north of the Townsend / Winona Road intersection, via Forest Road (FR 9139)
- Elden Lookout trailhead, located north of the Peaks Ranger District Office (5075 North Highway 89); also provides access to the Fatman's Loop Trail and Sandy Seep Trail
- Old Caves Crater Trailhead, located approximately 0.5 miles east of US 89 on the north side of Silver Saddle Road
- Cinder Lake Landfill Road Trailhead, located west of US 89 on Cinder Lake Landfill Road, providing access to the Old Caves Crater Trail
- Forest Service access point at the northern end of Stardust Trail

5. **Commercial Nodes:** Intersections with neighborhood commercial:

- US 89 / Snowflake Drive
- US 89 / Burris Lane
- US 89 / Silver Saddle Road
- US 89 / Campbell Avenue
- US 89 / Copeland Lane
- Townsend-Winona Road and Lumberjack/Slayton Road
- Townsend-Winona Road and I-40

## 2.3 Streets and Roadways

The existing road network in the study area is composed of an interstate highway (I-40), US 89, and a system of arterial, collector, and local streets. In addition to the municipal road system, there is also a system of U.S. Forest Service roads on the Coconino National Forest. Roads within the study area are shown in **Figure 2**.

### 2.3.1 Traffic Data

Daily traffic volumes on study area roadways were compared to maximum daily volume thresholds for Level of Service (LOS) C and LOS D to identify roadways that are approaching their maximum capacity. The daily volume thresholds for LOS C and LOS D shown in **Table 1** are derived from Highway Capacity Software. For reference purposes, similar threshold tables are found in *Table 4-1 in the Florida Department of Transportation's (FDOT) 2002 Quality/Level of Service Handbook*.

Roadway segments below the maximum volume threshold for LOS C likely do not currently need additional through capacity while roadway segments above the maximum volume threshold for LOS D likely will need additional capacity. For roadway segments between the maximum volume thresholds for LOS C and LOS D, more detailed analysis should be conducted to evaluate intersection geometry, signal timing, and number and spacing of driveways to determine if additional through capacity is needed.



### *Existing Level of Service*

Based on the maximum volume thresholds in **Table 1** and the existing (2008) daily volumes from **Table 2** and **Table 3**, no study area roadway segments, for which existing traffic count volumes were available, currently exceed the maximum volume for LOS C or D.

### *Future Level of Service*

The ADOT Multimodal Planning Division provides 20-year traffic projections on state highway segments. These segment-by-segment traffic volume forecasts and annual growth rates were developed through a regression analysis of historical vehicle travel activity at various levels of aggregation. Forecast 20-year daily traffic on US 89 is shown in **Table 2**.

**Table 3** shows 2030 traffic forecast volumes for other roads in the study area. These traffic forecast volumes were obtained from the *Engineering Study for Townsend – Winona Road and Leupp Road*.

Based on the maximum volume thresholds in **Table 1** and the forecast daily volumes from **Table 2** and **Table 3**, road segments that are projected to drop below LOS C in 2030 are Townsend-Winona Road, from US 89 to Rain Valley Road, and US 89 south of the Townsend-Winona Road. As traffic volumes on these roadways increase, detailed analysis of intersection geometry, traffic control, and access management should be conducted to determine if additional capacity is required.

### **2.3.2 Crashes**

Five years of crash data were obtained and analyzed from ADOT. These data spanned a period from 1/1/2004 to 12/31/2008. During this time period 737 crashes occurred. The crashes predominately occurred on US 89, I-40, and Townsend-Winona Road. There were nine fatal crashes and 36 incapacitating-injury/severe injury crashes during this analysis period. Approximately 68% of the crashes involved no injury, 17% of the crashes involved a non-incapacitating injury, and 9% of the crashes involved a possible injury. Single-vehicle crashes accounted for the largest proportion of crashes (62%). This was followed by rear end collisions (16%). During this time period there were four pedestrian-motor vehicle crashes and one bicycle-motor vehicle crash.

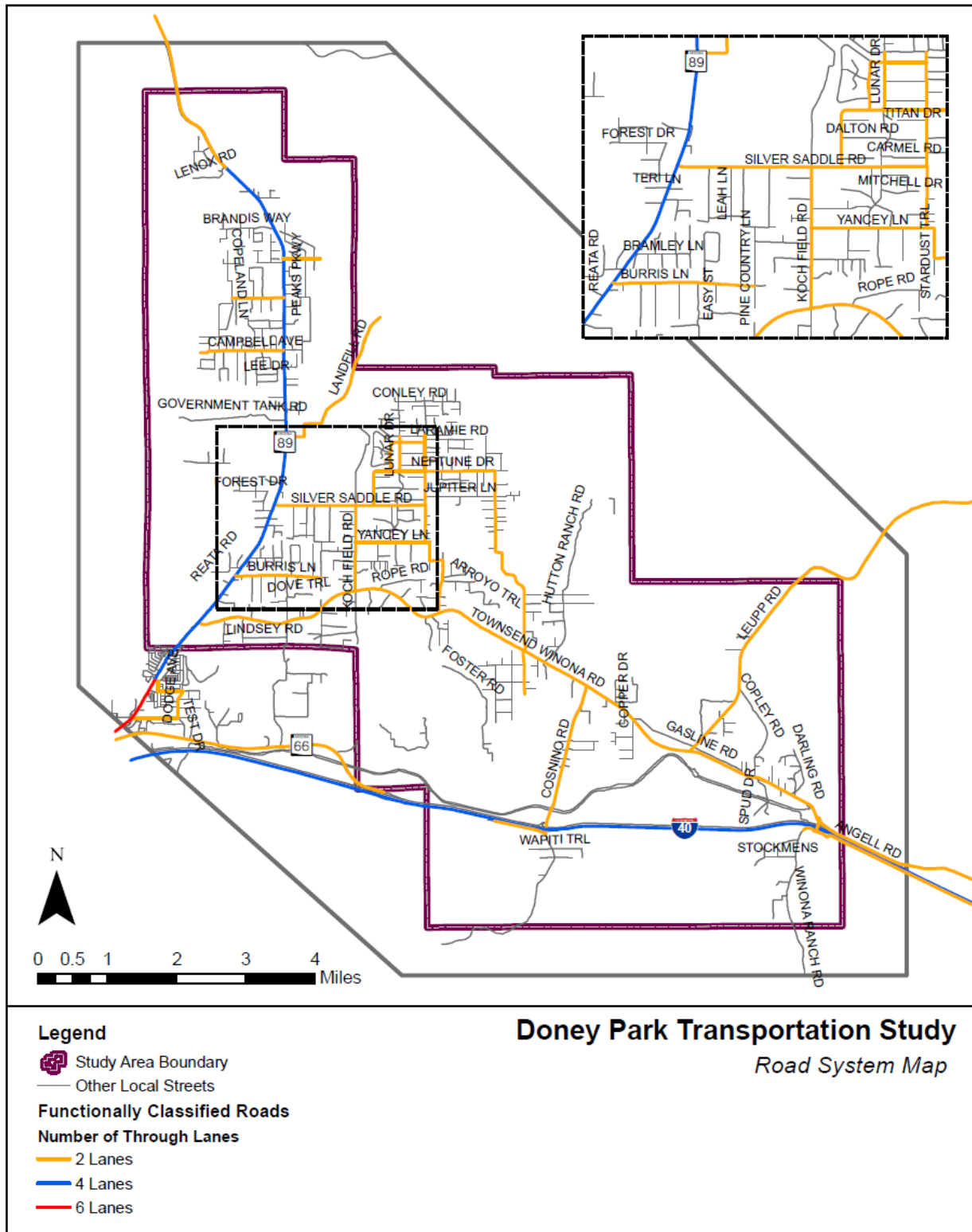

Figure 2 – Road System Map



**Table 1 – Maximum Daily Volume Thresholds for LOS C, D, and E**

Roadway Category	Number of Through Lanes	Maximum Volume for LOS B	Maximum Volume for LOS C	Maximum Volume for LOS D	Maximum Volume for LOS E
Collector/Arterial with no left-turn lanes	2	2900	8,600	10,800	11,500
Collector/Arterial with center left-turn lanes	2	3800	11,000	13,400	14,100
Collector/Arterial with raised medians and left-turn lanes	4	8300	23,700	27,000	28,400
Uninterrupted flow highway	2	5500	11,300	16,600	21,500

Source: Kimley-Horn and Associates, Inc, Highway Capacity Software

**Table 2 – Existing and Future Daily Traffic Volumes on US 89**

Road	Road Segment	2008 AADT	2028 Traffic Forecast	Annual Growth Rate (%)	Long Term 20-year Growth Rate (%)	2028 LOS
US 89	Country Club/SB-40 to Townsend-Winona Road	26,000	36,000	1.57%	38.5%	F
	Townsend – Winona Road to Silver Saddle Road	16,500	23,500	1.80%	42.4%	C
	Silver Saddle Road to Sunset Crater National Forest Service Road 545	6,600	8,700	1.35%	31.8%	C

Source: Arizona State Highway System 20-year daily traffic forecasts, <http://www.azdot.gov/mpd/data/Reports/PDF/SHS2028AADTForecastsver2.pdf>, referenced 8/13/2010.

**Table 3 – Existing and Future Daily Traffic Volumes on Study Area Roadways**

Road	Road Segment	2007 AADT	2030 Traffic Forecast	Annual Growth Rate (%)	Long Term 20-year Growth Rate (%)	2030 LOS
Cosnino Road	I-40 to Townsend-Winona Road	1,700	4,000	3.79%	135.3%	C
Leupp Road	North of Townsend-Winona Road	3,700	7,000	2.81%	89%	C



**Table 3 – Existing and Future Daily Traffic Volumes on Study Area Roadways (continued)**

Road	Road Segment	2007 AADT	2030 Traffic Forecast <sup>1</sup>	Annual Growth Rate (%)	Long Term 20-year Growth Rate (%)	2030 LOS
Townsend-Winona Road	US 89 to Rain Valley Road	7,600	11,400	1.78%	50%	D
	Rain Valley Road to Koch Field Road	6,100	10,600	2.43%	73.8%	C
	Koch Field Road to Slayton Ranch Road / Lumberjack Boulevard	4,600	10,000	3.43%	117%	C
	Slayton Ranch Road / Lumberjack Boulevard to Cosnino Road	4,200	7,000	2.25%	66.7%	C
	Cosnino Road to Leupp Road	3,000	6,000	3.06%	100%	C
	Leupp Road to I-40	2,100	4,000	2.84%	90.5%	C
	US 89	South of Townsend-Winona Road	28,380	38,000	1.28%	33.9%

Source:

- 1) *Final Engineering Study for Townsend – Winona Road, Jct. 89 to Jct. I-40, Leupp Road, Jct. Townsend-Winona Road, East 1 mile, page A-21.*
- 2) *Kimley-Horn and Associates, Inc, Highway Capacity Software Analysis*

### 2.3.3 Roadway Winter Maintenance Practices

A stated objective of the Doney Park Multimodal Transportation Study is to evaluate winter roadway maintenance practices.

Coconino County Public Works, Maintenance Division, currently applies de-icing chemicals on the following roadways in Doney Park:

- Townsend-Winona Road (entire length)
- Cosnino Road (only on major incline just north of railroad tracks)
- Koch Field Road (only on major incline just south of Rio de Flag)
- Silver Saddle Road (only on major inclines just west of Koch Field Road)





At the onset of the study, Coconino County was interested to understand public perception related to winter roadway maintenance in the Doney Park area. As such, public input was obtained on roadway winter maintenance practices at a public meeting held on September 30, 2010. Based on the review of comments submitted, the following issues were identified:

- Snow plowing often leaves large berms across driveways that are difficult for residents to move.
- Snow is often pushed onto the sidewalk forcing children to walk in the road.
- De-icing chemicals may cause harm to the trees.
- Plowing of US 89 often leaves snow berms across connecting streets.

Input received from the public was provided to Coconino County. Generally speaking, while the public identified some issues related to winter roadway maintenance, it was determined that no changes to winter roadway maintenance practices are required at this time. As such, the Doney Park Multimodal Transportation Study does not recommend changes to current winter roadway maintenance practices

## 2.4 Pedestrian and Bicycle Facilities

Bicycle and pedestrian facilities are an important part of the multimodal transportation network in that they provide alternative options for travel. Pedestrian networks are typically comprised of sidewalks, trails, or shared-use paths. Bicycle networks can include streets that are designated as bicycle routes and may include striped bicycle lanes, shared lanes, or paved shoulders.

### 2.4.1 Existing Pedestrian Paths and Sidewalks

Existing pedestrian facilities in the study are summarized in **Table 4**.

**Table 4 – Pedestrian Facilities**

Road Name	Feature	Termini	Total Length (linear feet)
Campbell Avenue	Unpaved Trail	US 89 to USFS boundary (only on north side of Campbell Ave.)	6,864
Koch Field Road	Paved Trail	Silver Saddle Rd. to Kavanaugh Way (only on east side of Koch Field Rd.)	4,224
Neptune Drive	Unpaved Path (informal)	Stardust Trail to Slayton Ranch Road	5,220 ft
Silver Saddle Road	Sidewalk	Koch Field Rd. to Skeet Dr. (both sides of Silver Saddle Rd.)	2,640
	Unpaved Trail	Skeet Dr. to Stardust Tr. (only on south side of Silver Saddle Rd.)	3,960
US 89	Sidewalk	I-40 to south side of Townsend- Winona Road (both sides of US 89)	9,050 (approx.)

Source: Coconino County



## 2.4.2 Existing Trails

Trails connect residents and visitors to recreational areas, open space, and other activity centers. The primary trail systems in the study area are:

1. **National Forest System trails/roads**, which include the Sandy Seep Trail, Little Elden Trail, Fatman's Loop, and the Old Caves Crater Trail in the study area.
2. **Flagstaff Loop Trail (FLT)** is a 42-mile regional pathway that intersects with most regional highways and provides connectivity between public lands and many Flagstaff area neighborhoods via the City of Flagstaff's Urban Trail System. In the study area it overlaps with segments of the Arizona Trail and Forest Service trails such as the Sandy Seep Trail.
3. **Flagstaff Urban Trail System (FUTS)** is a city-wide network of non-motorized, shared-use pathways. At present there are approximately 50 miles of FUTS trails in Flagstaff.
4. **Arizona Trail** is an 800-mile trail which, when completed, will extend from Mexico to Utah. It traverses the southwestern part of the study area.

A brief description of each of these trail systems is provided in the following sections. Existing trails are summarized in **Table 5**. Trails in the Doney Park area are shown in **Figure 3**.

### 2.4.2.1 National Forest Service Trails

There are numerous trails throughout the Coconino National Forest within the study area. The main trails which can be accessed from US 89 are the Sandy Seep Trail, Fatman's Loop, and the Elden Lookout Trail. The Old Caves Crater Trail has its main access from Silver Saddle Road. It also has an access from Cinder Lake Landfill Road.

### 2.4.2.2 Flagstaff Loop Trail

The Flagstaff Loop Trail (FLT) is a 42-mile non-motorized trail which includes existing trails, portions of the Arizona Trail, social trails, and two-track road converted to trail. Currently, the trail is disconnected, but approximately 20 miles have been completed. When completed, the 42-mile trail will circumnavigate Flagstaff, providing access from all areas of the city. The FLT links to the FUTS, Coconino National Forest System trails, and the Arizona Trail. It is designed to provide non-motorized recreation and commuter users with access to public lands and public spaces throughout Flagstaff. FLT is a collaborative project between Coconino National Forest, Flagstaff Biking Organization (FBO), City of Flagstaff, and Coconino County. Additional data on the Loop Trail can be found on the website <http://flagstaffbiking.org/loop-trail/>.

### 2.4.2.3 Flagstaff Urban Trail System

The Flagstaff Urban Trails System (FUTS) is a city-wide network of non-motorized, shared-use pathways that are used by bicyclists, walkers, hikers, runners, and other users for both recreation and transportation. Presently there are approximately 50 miles of FUTS trails in Flagstaff. The overall master plan shows approximately 80 miles of future trails, to complete a planned system of 130 miles. About half of the miles of existing trails are paved, either in concrete or asphalt, and half consist of a hard-packed, aggregate surface. FUTS trails are generally eight or ten feet



in width. There is a North 89 trail which extends from Marketplace Drive on US 89 to Snowflake Drive at the south boundary of the study area. There are planned FUTS trail connections on US 89 and Route 66.

#### **2.4.2.4 Arizona Trail**

The Arizona Trail is more than 800 miles extending from Mexico to Utah connecting numerous sites throughout Arizona. It is designated as a National Scenic Trail. The trail is divided into 43 passages. In the Doney Park area, passage 32-Mt. Elden extends from I-40 west of the Cosnino Exit to Schultz Pass. The trail passes under the BNSF railroad, and heads west. It follows Wildcat Canyon then extends west across a large open area. The trail continues northwest up to the Rio de Flag and a bridged crossing. Climbing out of this drainage, the trail crosses a number of two-track roads and then passes under Highway 89, and turns to the northeast as it reaches the junction to the Sandy Seep Trailhead. The route then follows the Sandy Seep Trail, connects with the Little Elden Trail, climbs up and around Little Elden Mountain, and then reaches Schultz Pass Road and the Schultz Pass Trailhead.

#### **2.4.3 Proposed Trails and Off-Street Facilities**

This section describes trails that have been proposed in previous plans and studies. Proposed trails are shown in **Figure 3**.

##### **2.4.3.1 Timberline Trail**

The Timberline Trail has previously been proposed within the study area. It is a proposed north-south route located west of US 89. The trail would provide access to U.S. Forest trails along Mount Elden, the FUTS, and the Flagstaff Loop Trail. Currently, a final decision regarding the trail has not been made.

##### **2.4.3.2 Townsend-Winona Road Trail**

As part of the *Engineering Study for Townsend – Winona Road (Junction 89 to Junction I-40) and Leupp Road (Junction Townsend – Winona Road, East 1 mile)*, pathways are recommended along the Townsend-Winona Road. It was noted that in the areas where the Townsend-Winona Road corridor lies next to the Coconino National Forest Service Lands, it may be desirable to place the path on Forest Service Lands. Other suggestions were that the County may want to consider pathway construction at certain locations to complement the existing adjacent pathway system. An example was a connection to Koch Field Road. It was also suggested that pathways should be constructed for both pedestrians and horses, but barriers needed to be placed to prevent ATVs from using the pathways. It was noted that some equestrian groups may request horse step-through gates at certain locations in the right-of-way fence.

##### **2.4.3.3 Picture Canyon Trail**

The Picture Canyon Trail is proposed as a future trail in the FUTS. The location of the proposed trail has not yet been determined. Options have been proposed along Rain Valley Road/FR 510E and the Rio de Flag Floodplain, and connecting to Townsend-Winona Road.



**Table 5 – Study Area Trails**

Trail Name	Jurisdiction	Endpoints	Length (miles)	Surface	Rating (based on Grades) <sup>1</sup>	Connects Activity Centers	Intersecting Trails	Comments
<b>Coconino County Trails</b>								
Peaks View County Park Trail	Coconino County	Perimeter trail around Peaks View County Park	1	Graded	Easy	Peaks View County Park	None	
<b>Flagstaff Loop Trail (partnership with Coconino National Forest, Flagstaff Biking Organization (FBO), City of Flagstaff, and Coconino County)</b>								
Flagstaff Loop Trail	Crosses multiple jurisdictions	N/A	42	A mix of unpaved and paved trails	Varies	Townsend-Winona Road/US89 to Activity Centers in Flagstaff.	Links to the FUTS, US Forest System trails, and the Arizona Trail.	
<b>U.S. Forest Service Trails</b>								
Elden Lookout Trail #4	U.S. Forest Service – Coconino National Forest	Peaks Ranger Station	3	Graded	Strenuous	Peaks Ranger Station Mount Elden Flagstaff Mall	Fatman's Loop Oldham Trail	
Fatman's Loop Trail #25*		Peaks Ranger Station	2	Graded	Easy	Peaks Ranger Station Flagstaff Mall	Elden Lookout Trail	
Old Caves Crater Trail		Base of extinct cinder cone volcano, Silver Saddle Road	1.3	Graded	Moderate	Old Caves Crater Silver Saddle Road	Crater Loop Trail	Coconino National Forest Trail Entry via Silver Saddle Road



**Table 5 – Study Area Trails (continued)**

Trail Name	Jurisdiction	Endpoints	Length (miles)	Surface	Rating (based on Grades) <sup>1</sup>	Connects Activity Centers	Intersecting Trails	Comments
Sandy Seep Trail #129		Forest Road 9139 to Little Elden Trail	1.5	Graded	Moderate	Mount Elden Equestrian Bypass of Arizona Trail	Little Elden Trail Heart Trail	Coconino National Forest Trail closed to entry by cars Entry via Forest Road ½ mile north of Townsend Winona Road
<b>Flagstaff Urban Trail System Trail (FUTS)</b>								
North 89 Trail*		Marketplace Drive to Snowflake Drive	1.1	Concrete: 100 percent of the trail (1.1 mi   1.7 km)	Easy	Christensen School USFS Peaks Ranger Station Mt. Elden Trailhead	El Paso Trail Mt. Elden Lookout Trail (USFS)	This trail ends south of the study area

<sup>1</sup>Ratings:

- Easy: (grades <5%)
- Moderate (grades between 5 and 10 %)
- Steep (grades between 10 and 15%)
- Very Steep (grades > 15%)

Source: Coconino National Forest Website: [http://www.fs.fed.us/r3/coconino/recreation/peaks/rec\\_peaks.shtml](http://www.fs.fed.us/r3/coconino/recreation/peaks/rec_peaks.shtml), accessed 7/7/10,

\*The Fatman's Loop Trail and North 89 Trail are outside of the study area, but they are in close proximity to the study area and connect to trails that are within the study area.

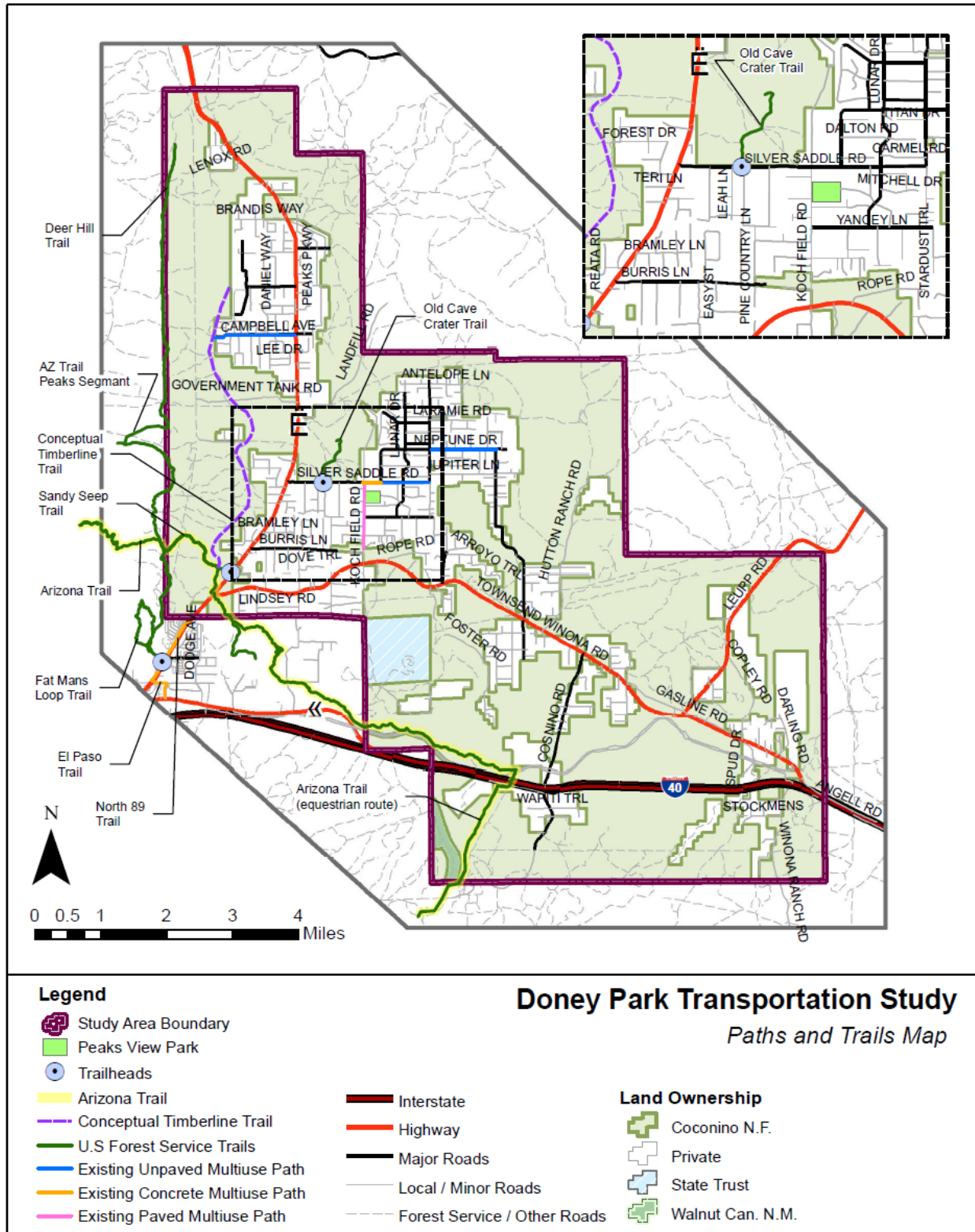

**Figure 3 – Existing and Proposed Trails**



## 3 STAKEHOLDER AND PUBLIC INPUT

### 3.1 Stakeholder Interviews

Stakeholder interviews were conducted to obtain input on needs and opportunities for multimodal transportation in the Doney Park area. Stakeholder interviews were conducted with representatives of Northern Arizona Intergovernmental Public Transportation Authority, Coconino County Parks and Recreation, Flagstaff Biking Organization, Flagstaff Metropolitan Planning Organization, Coconino County Board of Supervisors, Coconino County Sheriff's Office, Flagstaff Unified School District, U.S. Forest Service, Coconino County Horseman's Alliance, and the Black Bill Neighborhood Association.

### 3.2 Public Open Houses

Two rounds of public meetings were conducted. The first public open house was held on Thursday, September 30, 2010 at Cromer Elementary School. The purpose of the public open house was to obtain input and identify areas where multimodal transportation is most desired or needed.

A second public meeting was held on April 28, 2011. The purpose of the public meeting was to obtain input on specific projects that are proposed within the Doney Park area.

### 3.3 Stakeholder and Public Input Findings

Stakeholder and public input generally focused on three key multimodal transportation needs in the Doney Park area:

- A system of shared-use paths that connects activity centers, U.S. Forest Service trail access points, and the FUTS. The system should be designed and constructed to accommodate a variety of users including pedestrians, bicyclists, and equestrians. Equestrian paths, where feasible, should be separated from pedestrian and bicycle paths. However, all users including pedestrians, bicyclists, and equestrians, must show mutual respect towards one another.
- Bicycle routes, bicycle lanes, or paved shoulders that can be used by bicyclists.
- Select roadway improvements to establish or improve connectivity.

Public input was also received regarding transit needs and deficiencies. This input will be provided to the Northern Arizona Intergovernmental Public Transportation Authority (NAIPTA) for their consideration.



## 4 PROPOSED PROJECTS

Proposed multimodal transportation projects in the Doney Park area are depicted in **Figure 4**. The projects address needs as identified through input from the Technical Advisory Committee, public and stakeholder input, and an assessment of existing and future conditions by the study team. Proposed multimodal projects consist of the following project elements:

- Roadway connections
- Shared-use paths to accommodate pedestrians, bicyclists, and other users
- Equestrian paths constructed of soft surface materials suitable for horses
- Sidewalks
- Paved shoulders
- Bike lanes and signing
- Transit service

The following served as references to the development of path and sidewalk concepts:

- Flagstaff/Coconino County/ADOT Pedestrian and Bicycle Design Guide
- AASHTO Guidelines for the Development of Bicycle Facilities, 1999
- AASHTO Guide for the Planning, Design, and Operation of Pedestrian Facilities, 2004
- Manual on Uniform Traffic Control Devices (MUTCD) for Signing and Striping, 2003 (Note that the MUTCD 2009 edition has not yet been adopted by ADOT)
- Equestrian Design Guidebook for Trails, Trailheads, and Campgrounds, U.S. Department of Agriculture, 2007

### 4.1 Roadway Connectivity

Roadway projects that are needed to improve connectivity, mobility, and emergency response are:

- Improve the existing Neptune Lane from Lunar Drive to Stardust Trail to County standards; this road is currently unpaved and requires grading and paving to Coconino County standards. These improvements would likely require formation of an improvement district.
- Construct a new road that extends Burris Lane from its current terminus at Pine Country Lane to Koch Field Road.

### 4.2 Shared-Use Paths

A network of shared-use paths is proposed in Doney Park and surrounding areas, including along US 89, Townsend-Winona Drive, Cosnino Drive, and Silver Saddle Road. The proposed pathway network will be comprised of paved paths as well as soft surface/natural surface paths for both pedestrians and equestrians. **Figure 4** reflects the proposed locations of each type of path. Please note that ADOT does not allow equestrian use within ADOT right-of-way.



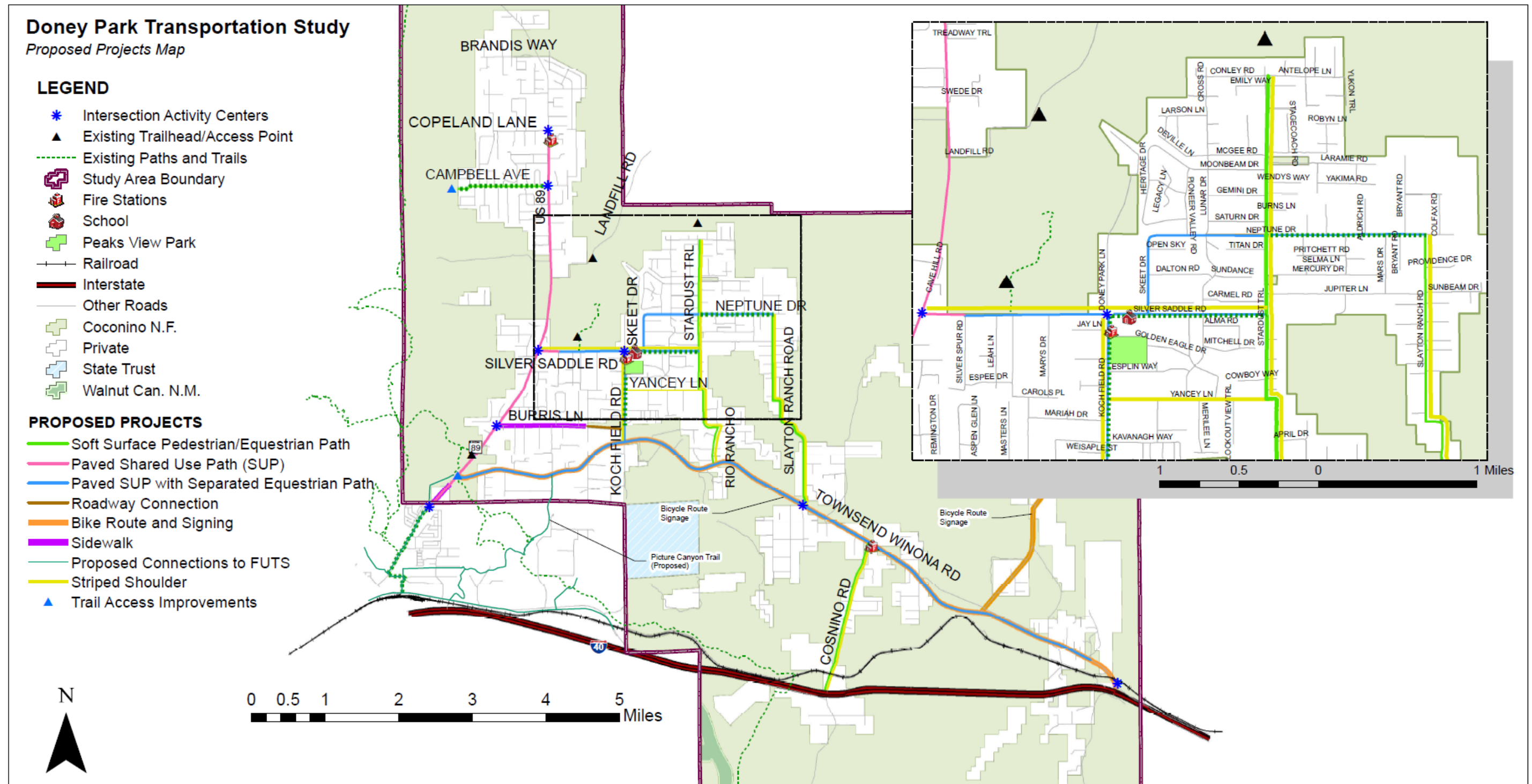

Figure 4 – Proposed Projects



### 4.2.1 Cautions for Shared-Use Paths Adjacent to Roadways

Planners and engineers should be aware of issues associated with shared-use paths. The *AASHTO Guide for the Development of Bicycle Facilities* (1999) identifies nine specific issues associated with paths located immediately adjacent to the roadway. Pathway design should address these issues to the extent feasible. These include:

- Paths located on just one side of the road require one direction of bicycle traffic to ride against motor vehicle traffic.
- When the path ends, bicyclists going against traffic will tend to continue to travel on the wrong side of the road.
- At intersections, motorists entering or crossing the roadway will not notice the bicyclist approaching from their right.
- Signs posted for roadway users are backwards or contra-flow for bicycle traffic.
- Many bicyclists will use the roadway instead of the shared-use path because they have found the roadway to be more convenient, better maintained, or safer. Bicyclists using the roadway may be harassed by motorists who feel that in all cases cyclists should use the adjacent path.
- Motorists falsely expect bicyclist to stop or yield at all cross-streets and driveways.
- Stopped cross-street motor traffic or vehicles exiting side streets may block the path crossing.
- Barriers are often necessary to keep vehicle traffic out of shared-use paths. These barriers can represent obstructions to bicyclists and motorists and can complicate the maintenance of the facility.

The Guide concludes that “shared-use paths should not be considered a substitute for street improvements (e.g., bicycle lanes, paved shoulders) even when a path is located adjacent to the highway.”

Within the Doney Park study area, wide shoulders and bike lanes are proposed on major roadways, in addition to the shared-use paths. On state routes (US 89) pathway design will adhere to *ADOT Traffic Engineering Policies, Guidelines, and Procedures Number 1031-Signing and Marking of Shared-use paths*.

### 4.2.2 Shared Use Path Courtesy

Shared use paths will attract a variety of user groups including bicyclists, walkers, strollers, and equestrians. Each user group often has conflicting needs. For example, pedestrians are impacted by other trail users including bicyclists who travel at high speeds; horses are sensitive to sudden movements or unexpected noises, and users with disabilities are unable to react quickly to hazards.

While the Doney Park Multimodal Transportation Study recommendations include separate facilities for each user group where feasible, in some cases user groups will utilize a common space and must learn to respect one another.

The Arizona State Parks provides simple steps when using shared-use paths and trails (<http://azstateparks.com/trails/share.html>):



- Respect other users; expect other users. Show courtesy.
- Be friendly and courteous. Greet other folks with a simple “hello!” or “nice day today!” Avoid greetings which may be misconstrued such as “on your left.”
- Pedestrians yield to equestrians. Bicyclists should yield to everyone. When in doubt, give other users the right of way.
- Announce yourself when approaching others, especially from behind.
- Use your voice to warn equestrians, not bells or horns, which may frighten horses. When a horse approaches move to the safest or most open side of the trail or ask the rider for instructions.
- Use caution and stay extra alert if using headphones or ear-buds — you may not be able to hear others.
- Be considerate, keep dogs leashed and under control at all times.



As the trail system is developed, conflicts between user groups can be reduced by (*Federal Highway Administration, Designing Sidewalks and Trails for Access, 2001*):

- Providing information, including signage, in multiple formats that clearly indicates permitted users and rules of conduct;
- Ensuring that the shared-use path provides sufficient width and an appropriate surface for everyone, or providing alternate paths for different types of users;
- Providing sufficient separation for users traveling at different speeds. For example, if volume and space permits, bicyclists and pedestrians should have different lanes or pathways;

#### 4.2.3 Paved Surface Shared-Use Path

Paved shared-use paths are designed to accommodate pedestrians, slow-speed bicyclists (e.g., children riding to and from school), and wheeled devices such as strollers. Bicyclists travelling at higher speeds (e.g., in excess of 10 to 15 mph) should not utilize the paved shared-use path, but should utilize the adjacent roadway and paved shoulder/bike lane. Signage or pavement markings on the shared-use paths may be considered, such as speed limit signs or pavement markings that encourage bicycles to maintain low speeds. However, signage and pavement markings on pathways within ADOT right-of-way should be consistent with *ADOT Traffic Engineering Policies, Guidelines, and Procedures Number 1031- Signing and Marking of Shared-use paths*.

Paved shared-use paths are not conducive for equestrian use, as they can be slippery to horses. Where paved shared-use paths are proposed, an equestrian path is proposed on the opposite side of the roadway, with exception to US 89 where stakeholder input indicated that traffic volumes and speeds are not conducive to equestrians. A typical section of a paved shared-use path with an accompanying equestrian path, on the opposite side of the road, is shown in **Figure 5**.

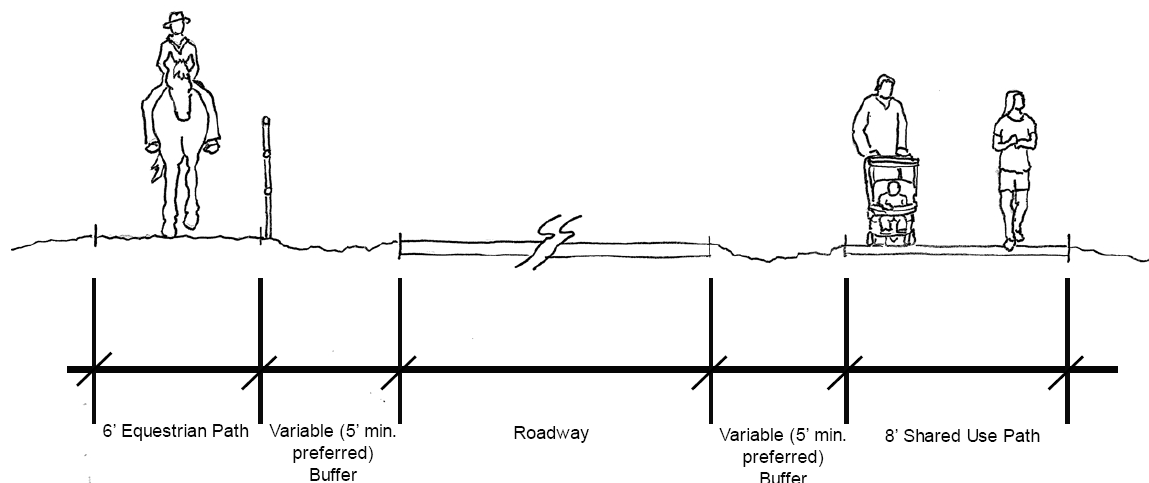

**Figure 5 – Shared-Use Path: Paved Path with Equestrian Path**

AASHTO Bicycle Guide (*AASHTO Guidelines for the Development of Bicycle Facilities*) states that the ideal minimum width of a two-directional paved shared-use path, under most conditions, is 10 feet. However, the Guide states that under certain conditions, a reduced width of eight feet can be adequate. These conditions are:

1. Bicycle traffic is expected to be low,
2. Pedestrian use of the facility is not expected to be more than occasional, and
3. Good horizontal and vertical alignment provides safe passing opportunities.

Most of the proposed pathways in Doney Park meet the above conditions to satisfy a reduced (eight-foot) pathway width. As such, paved paths along minor roadways where bicycle and pedestrian use is expected to be lower are proposed to be eight feet wide.

Paved paths along major roadways such as Townsend-Winona Road, where bicycle and pedestrian use are expected to be higher, and wider right-of-way is available, are proposed to be 10 feet wide as illustrated in **Figure 6**. Note that paved shoulders and bicycle lanes are also proposed on higher volume and higher speed roadways such as Townsend-Winona Road.

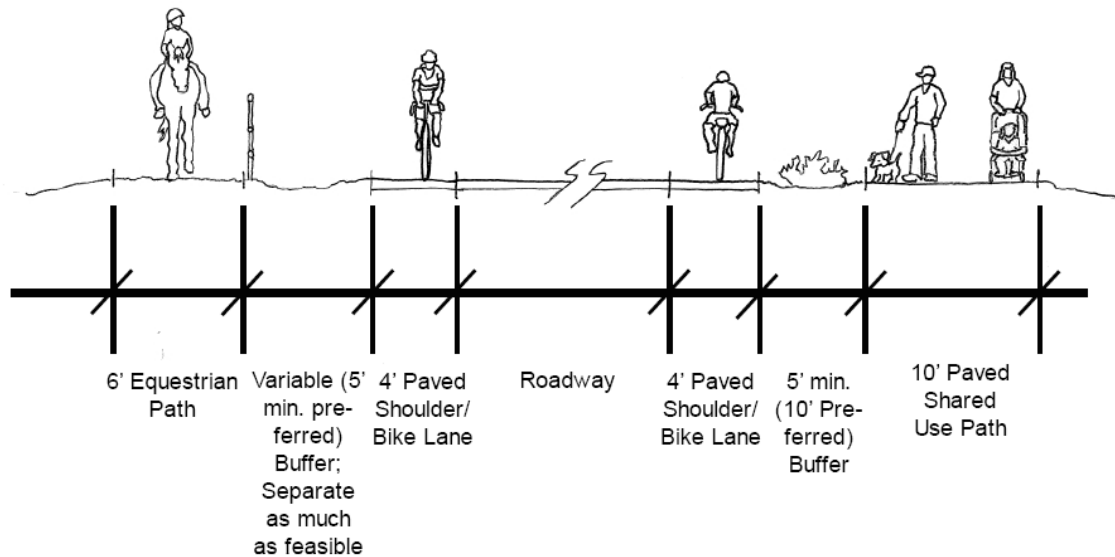

**Figure 6 – Shared-Use path: Paved Path with Equestrian Path and Bicycle Lane**

Paved paths may be constructed of multiple types of materials. Asphaltic concrete (AC) (commonly referred to as “asphalt”) represents an economical treatment. This type of path is comprised of three-inch AC on six-inch aggregate base on six-inch scarified and compacted subgrade (**Figure 7**).

Portland cement concrete (commonly referred to as “concrete”) is recommended in areas with significant cross drainage and swales. This type of path is comprised of a four-inch concrete on four-inch aggregate base on six-inch scarified and compacted subgrade (**Figure 7**). All paths should include a two-foot graded shoulder on each side of the path. Lateral clearances of three feet and vertical clearances of eight feet should be maintained. Features of a paved shared-use path are summarized in **Table 6**.

Shared-use paths should be designed to meet Americans with Disabilities Act (ADA) requirements. The FHWA Office of Civil Rights includes the following ADA guidance:

- Shared-use paths and pedestrian trails that function as sidewalks shall meet the same requirements as sidewalks. Where shared-use paths and pedestrian trails cross highways or streets, the crossing also shall meet the same requirements as street crossings, including the provision of detectable warnings.
- Shared-use paths and pedestrian trails that function as trails should meet the accessibility guidelines proposed in the Access Board's Regulatory Negotiation Committee on Accessibility for Outdoor Developed Areas Final Report found at [www.access-board.gov/outdoor/outdoor-rec-rpt.htm](http://www.access-board.gov/outdoor/outdoor-rec-rpt.htm). This report also has guidelines for Outdoor Recreation Access Routes (routes connecting accessible elements within a picnic area, camping area, or a designated trailhead).
- Recreational trails primarily designed and constructed for use by equestrians, mountain bicyclists, snowmobile users, or off-highway vehicle users are exempt from accessibility requirements even though they have occasional pedestrian use.

**Table 6 – Paved Shared-Use Path Features**

Design Element	Considerations
Width	Ideally, 10 feet. 8 feet is acceptable when bicycle traffic is expected to be low, pedestrian use is expected to be occasional, and horizontal and vertical alignment provides safe and frequent passing opportunities.
Surface Type	Asphalt pavement; concrete pathways may be required in areas of cross drainage.
Special Considerations	Primary users are pedestrians and bicyclists traveling at a lower speed.

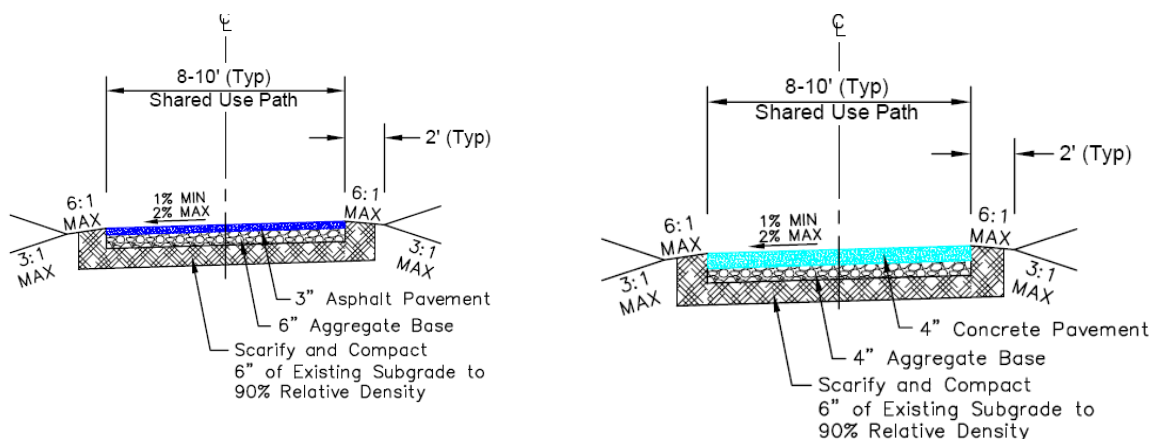

5A: Asphalt Pavement Typical Section

5B: Concrete Pavement Typical Section

**Figure 7 – Paved Shared-Use Path Typical Sections**

#### 4.2.4 Soft Surface Path for Equestrians and Pedestrians

The Doney Park area is home to an active equestrian community. Equestrians have expressed a desire to utilize pathways to access U.S. Forest Service lands and other recreational facilities such as Peaks View Park. However, paved asphalt pathways are not suitable for equestrian use, as they can be slippery for horses as they provide little traction for horseshoes.

To address the needs of the equestrian community, a network of soft surface paths are proposed throughout Doney Park. The soft surface paths are proposed to consist of surface materials suitable for horses.

The study team recognizes that the mixing of equestrians and other users on pathways, and in particular the mixing bicyclists and equestrians, is undesirable. The *AASHTO Bicycle Guide* states that bicyclists are often not aware of the need for slower speeds and additional operating space near horses. In addition, horses track mud and debris across the path, and may leave deposits that are unpleasant for bicyclists and pedestrians.

In as much, where sufficient right of way exists, a soft path and a paved path are proposed. Soft paths and paved paths are proposed on Koch Field Road, Townsend-Winona Road, Silver Saddle Road, Skeet Drive, and Neptune Drive. The soft path is proposed to be located on the opposite side of the street as the paved path. The soft paths along these roads will be as natural as



possible; they may be described as an ‘equestrian realm’ with minimal improvements such as minor clearing or covering of culverts.

Right of way and other limitations in some areas may preclude the development of a paved path and a soft path along the same roadway. Soft paths only are proposed on Stardust Trail, Slayton Ranch Road, Cosnino Road, and Campbell Ave.

Soft paths along these roads should be constructed so that they are suitable for equestrians and pedestrians. Surface treatments on these shared-use soft pathways should consider the needs of both user groups. Crushed and compacted rock, such as decomposed granite, may provide a suitable surface for both user groups.

As the number of pedestrians and equestrians along these roads is anticipated to be relatively low, equestrians and pedestrians should be able to co-exist on the same pathway where necessary, through demonstration of mutual respect and shared-use path courtesy.

The soft surface path design requires attention to the physical and behavioral characteristics of horses; a cross section is illustrated in **Figure 8**. The width (six feet minimum) may be increased where right-of-way, topography, drainage, and/or other constraints allow. Horizontal and vertical clearances should be provided to accommodate equestrians. Features of a soft surface path are summarized in **Table 7**.

Where feasible, a rail-height barrier may be constructed separating the pathway from the roadway. The physical barrier, if solid, should be no higher than 54” (*Equestrian Design Guidebook for Trails, Trailheads, and Campgrounds, USDA, 2007*).

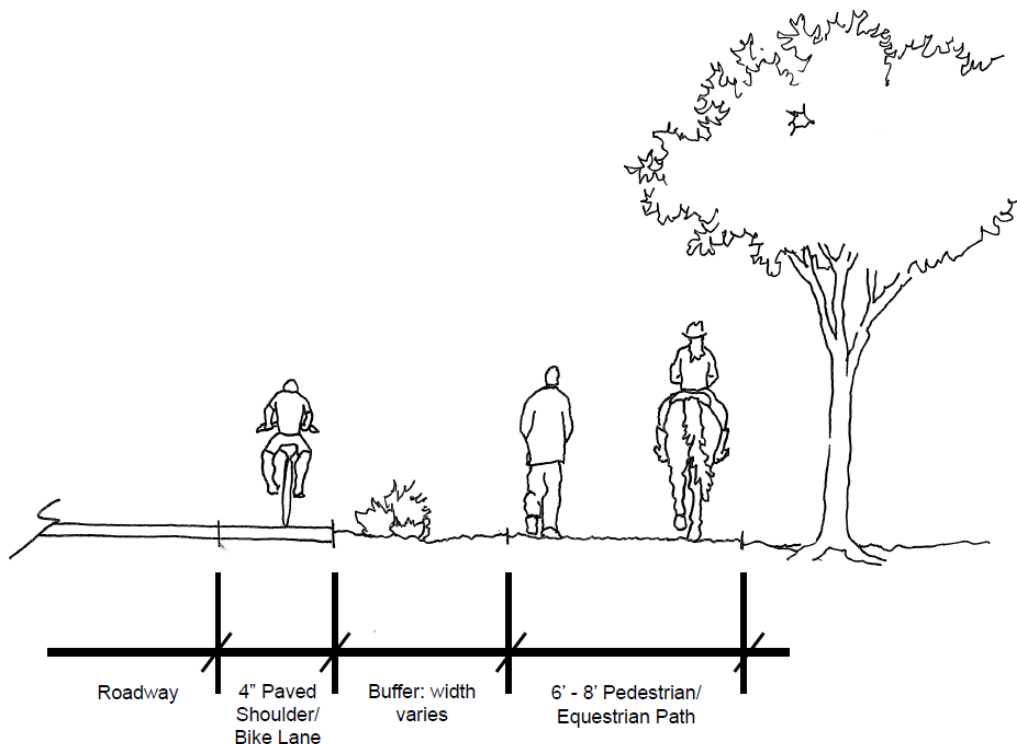

**Figure 8 – Soft Surface Equestrian and Pedestrian Path**



**Table 7 – Soft Surface Equestrian and Pedestrian Path Features**

Design Element	Considerations
Width	Soft surface equestrian and pedestrian paths will be at least 6 feet wide, and should provide vertical clearance of 10 to 12 feet.
Surface Type	<p>The path may be constructed of a number of materials including natural materials (native soil) and aggregates (crushed rock, cinders), or native-soil binders.</p> <p>Soft surface pathways that accompany a paved surface path may consist of compacted native soil with less stringent design and construction standards. Segments with only a natural surface pathway, without a paved pathway, will require engineered surface treatments. Fine aggregates provide good traction. Materials should be slip-resistant and able to withstand the impact of horseshoes. The ideal surface will produce minimal dust. Cinders are not preferred because of their poor durability and reduced horse comfort. The <i>Equestrian Design Guidebook for Trails, Trailheads, and Campgrounds</i> indicates that crushed rock with fines provides excellent traction for horses, has excellent durability, provides good horse comfort, requires low maintenance, and is moderate in cost.</p>

### 4.3 Sidewalks

Sidewalks are proposed in areas with existing curb and gutter, or in areas with physical features, constrained right-of-way, or access considerations that prohibit construction of a shared-use path separated from the roadway.

Within the Doney Park area, proposed sidewalks are limited to Burriss Lane (due to limited right-of-way and drainage constraints) and along US 89 south of Townsend-Winona Road to connect to existing sidewalks. No other sidewalk segments are proposed in the study area.

Sidewalks along Burriss Lane may be five feet wide. Sidewalks along high volume streets (US 89) should be six feet wide. While ADOT standard (C-05.20) “typical” sidewalk is five feet wide, the ADOT Roadway Design Guidelines allow for greater sidewalk width when required by local engineering standards. City of Flagstaff Engineering Standards identifies a minimum width of six feet adjacent to major arterials.

### 4.4 Paved Shoulders

The *AASHTO Guide for the Development of Pedestrian Facilities* states that in rural areas, paved shoulders along low traffic volume streets can provide a suitable pedestrian facility. The Guide states that minimum roadway shoulder widths as recommended in the *AASHTO Green Book (Policy on Geometric Design of Highways and Streets)* can accommodate occasional pedestrian travel. The *AASHTO Green Book* recommends a minimum usable shoulder width of four feet where bicyclists and pedestrians are to be accommodated on the shoulders. A white edge line delineates and defines the space for both motor vehicles and pedestrians/bicyclists.

Providing paved shoulders does not always require roadway widening. In many cases, paved shoulders can be achieved through reallocating pavement width by narrowing the travel lanes





and striping or restriping the existing roadway. Reducing lane widths may allow for a paved shoulder to be added to a roadway without adding additional pavement.

Existing roadways within Doney Park typically consist of a 28-foot-wide pavement width, consisting of two 14-foot travel lanes. To provide wide paved shoulders suitable for pedestrian and bicycle use, lane widths can be reduced and the roadway can be striped to consist of two 10-foot travel lanes and two four-foot shoulders. Reducing the width of travel lanes to 10 feet not only allows enough room for a paved, striped shoulder to be added to the street cross-section, but narrower travel lanes also have a tendency to slow vehicle speeds.

Safety is a common concern regarding lane width reduction. However, research conducted by the Midwest Research Institute, *Relationship of Lane Width to Safety for Urban and Suburban Arterials*, concludes that travel lanes on arterial and collector roadways with 10- and 11-foot travel lanes do not increase the frequency of crashes (<http://www.completestreets.org/webdocs/resources/lanewidth-safety.pdf>).

The Midwest Research Institute report recommends that jurisdictions provide flexible cross-sections to allow for narrower travel lanes when appropriate. Their recommendation is supported by AASHTO, which recommends that “under interrupted-flow operating conditions at low speeds (45 mph or less), narrower lane widths are normally adequate.” (*AASHTO Policy on Geometric Design of Highways and Streets, 2004, page 473*).

Another common concern about reducing lane widths is the potential impact on roadway capacity. However, the Pedestrian Bicycle Information Center describes recent research that finds roadway capacity is similar for lane widths between 10 feet and 12 feet, and that a measurable difference is not evident until lane widths are reduced to less than 10 feet (<http://www.walkinginfo.org/library/details.cfm?id=4348>).

#### **4.5 Bicycle Lanes and Bicycle Route Signage**

As described in the *AASHTO Guide for the Development of Bicycle Facilities*, bicycle lanes are incorporated into a street network when it is desirable to delineate road space for preferential use by bicyclists and motorists and to provide more predictable movements by each. Bicycle lane markings can increase a bicyclist’s confidence in motorists not straying into their path of travel; likewise, passing motorists are less likely to swerve to the left out of their travel lane to avoid bicyclists on their right (*AASHTO Guide for the Development of Bicycle Facilities, 1999, page 22*).

Generally, bicycle lanes are preferable on streets with posted speed limits of 30 mph or greater on roads with traffic volumes greater than 1,000 to 2,000 vehicles per day. Within the Doney Park area, bicycle lanes are proposed on Townsend-Winona and Leupp Road. Paved shoulders are also proposed on Silver Saddle and Koch Field Road, which may also be designated as bicycle lanes. Designation of bicycle lanes on US 89 would require an agreement with ADOT; current ADOT Bicycle Policy requires funding participation from local jurisdictions for the designation and maintenance of bicycle lanes.

*AASHTO Guide for the Development of Bicycle Facilities* recommends a minimum bike lane width of four feet on uncurbed sections with no vertical obstructions immediately adjacent to the roadway. A shoulder width of five feet is recommended from the face of a curb, guardrail, or



other vertical obstruction to the bike lane stripe to provide additional operating width as bicyclists will shy from the vertical face. The Guide states that additional widths are desirable where substantial truck traffic is present, or where motor vehicle speeds exceed 50 mph.

Generally, existing shoulder widths on Townsend-Winona and on Leupp Road are sufficient to accommodate a bicycle lane.

Rumble strips have been proposed on some Doney Park roadways to possibly prevent run-off-the-road crashes. While rumble strips can have safety benefits for motorists, rumble strips can have a negative impact on bicyclists. Rumble strips improperly installed in the center of a paved shoulder can render the paved shoulder useless to bicyclists. ADOT Rumble Strip Policy provides sound guidance that should be considered for any rumble strip installation within the Doney Park area. The rumble strip should be installed as far to the left as possible, ensuring that a sufficient rideable surface for bicyclists is maintained. ADOT design guidelines include gaps in the rumble strip to enable a bicyclist to enter and exit the paved shoulder and bicycle lane within the gaps.

#### **4.6 Shoulder Maintenance and Sweeping**

Debris on paved shoulders and on bicycle lanes is a concern voiced by stakeholders. Treating bicycle lanes as a functional travel lane by regularly and routinely removing debris from the paved shoulder and bicycle lanes will improve the safety and comfort of bicyclists.

Understanding that maintenance funds are limited, it is recommended that Coconino County, at a minimum, sweep cinder and debris from shoulders and bicycle lanes after winter maintenance practices have ceased for the season. As funding becomes available, it is recommended that a regular sweeping program consist of the following:

- Major arterials and streets with bicycle lanes: once per month
- Collector and residential streets (shared roadways and bicycle lanes): twice per year.

It should be noted that ADOT is responsible for the maintenance of state highways, including US 89. Maintenance concerns may be reported to the ADOT Flagstaff District.

#### **4.7 Detailed Project Descriptions**

Detailed descriptions of each project depicted in **Figure 4** are provided in Project Information Sheets in **Appendix A**.

The Project Information Sheets provide estimates of probable construction cost. Project limits “logical termini” for each project were defined based on what might reasonably be funded within a single project. Project scoping and construction costs assumed that the major source of funding for projects would be Transportation Enhancements and that federal environmental clearance would be required. Costs for development of the Project Assessment (PA), survey, environmental clearances, design, and construction are included.

Estimates of probable construction costs do not include costs for right-of-way acquisition. Determination of right-of-way costs requires detailed engineering and planning activities that are



beyond the scope of this study. Right-of-way costs will be determined as each individual project is designed.

It is important to note that at the time of the completion of the Doney Park Multimodal Transportation Study, no dedicated funding is specifically budgeted for implementation of the proposed projects. Potential funding sources are identified in Chapter 6, *Implementation Revenue Sources*, and additional funding opportunities may be identified in the future. There is no guarantee that funding will be obtained for full implementation of all the projects described herein or that all the projects will ultimately be completed.

## 4.8 Project Phasing

Each multimodal project is categorized into one of three phases: Phase I, Phase II, or Phase III. Project phases were developed considering the project need, anticipated benefit of the project, relative cost and complexity of the project, and relationship to other projects.

Specific timeframes are not assigned to the three project phases. It is expected that the projects will be constructed incrementally over a considerable period of time as opportunities arise and funding becomes available. Individual projects are also not locked into the phase in which they are listed, but may be constructed out of order as conditions warrant or priorities change over time. Projects may be initiated at any time after completion of the study, and full implementation of all the projects may not occur for 10 to 20 years or longer.

### 4.8.1 Phase I Projects

In general, Phase I includes projects that could potentially be included within currently programmed projects, projects that are needed to complete existing gaps, and projects that serve to establish a “trunk” for the ultimate Doney Park path system. Phase I projects are summarized in **Table 8**. The estimated cost is \$5.3 million.

### 4.8.2 Phase II Projects

These projects will fill in gaps in the path system in more developed areas. Phase II projects are summarized in **Table 9**. The estimated cost of Phase II projects is \$5.3 million.

### 4.8.3 Phase III Projects

These projects are typically in less developed areas but will provide needed links for a complete path system. These projects also include higher cost projects that may need significant lead time to obtain funding.

Phase III projects are summarized in **Table 10**. The estimated cost of Phase III projects is \$3.4 million. Note that cost estimates for some very large projects (e.g., crossings of US 89) are not included as additional planning and engineering effort is required to determine approximate costs. Crossings of US 89 are likely to cost several million dollars.

A summary of costs by phase is provided in **Table 11**. The total estimated cost of improvements for all phases is \$14 million.



**Table 8 – Phase 1 Recommended Projects**

Phase	Project Name	Street	Street Segment	Distance (miles)	Project Description	Cost
<b>PHASE 1 PROJECTS</b>	Cosnino-1	Cosnino Road	Townsend-Winona Road to Roan Road	0.94	Paved shoulder Equestrian and pedestrian path Pedestrian crossing	\$230,000
	Cosnino-2	Cosnino Road	Roan Road to connection with Arizona Trail	0.88	Equestrian and pedestrian path	\$255,000
	Cosnino-3	Cosnino	Cosnino Drive	0.40	Traffic calming	\$25,000
	Koch Field-1	Koch Field Road	Townsend-Winona Road to Kavanaugh Way /Anaya Road	0.42	Paved shoulder Paved shared-use path Equestrian path Pedestrian crossing	\$265,000
	Koch Field -2	Koch Field Road	Kavanaugh Way /Anaya Road to Silver Saddle Road	0.8	Paved shoulder Equestrian path	\$235,000
	Leupp-1	Leupp Road	Townsend-Winona Road to U.S. Forest Service Road 244	4.92	Bike route and signing	\$40,000
	Silver Saddle-1	Silver Saddle Road	US 89 to Koch Field Road	1.13	Paved shoulder Paved shared-use path Equestrian path	\$580,000
	Townsend-Winona-1	Townsend-Winona Road	US 89 to I-40	10.00	Bike route and signing	\$75,000
	Townsend-Winona-2	Townsend-Winona Road	US 89 to Koch Field Road	2.46	Paved shared-use path Equestrian path	\$1,060,000
	US 89-1	US 89	900 feet south of Townsend-Winona Road to Townsend-Winona Road	0.33	Sidewalk	\$85,000
	US 89-2	US 89	Snowflake Dr/Trails End (existing terminus of Flagstaff Urban Trail System, North 89 trail) to Townsend-Winona Road	0.75	Paved shared-use path	\$265,000



**Table 8 – Phase 1 Recommended Projects (continued)**

Phase	Project Name	Street	Street Segment	Distance (miles)	Project Description	Cost
<b>PHASE 1 PROJECTS (Continued)</b>	US 89-3	US 89	Townsend-Winona Road to Silver Saddle Road	3.74	Paved shared-use path	\$1,255,000
	US 89-4	US 89	Silver Saddle Road to Copeland Lane	2.88	Paved shared-use path	\$950,000
	US 89-6	US 89	City of Flagstaff City Limit to Townsend-Winona Road	0.5	Restripe travel lanes to provide a striped shoulder for use by bicyclists	\$25,000
				29.75	-	\$5,345,000



**Table 9 – Phase 2 Recommended Projects**

Phase	Project Name	Street	Street Segment	Distance (miles)	Project Description	Cost
<b>PHASE 2 PROJECTS</b>	Burris-1	Burris Lane	US 89 to Green Prairie Lane	0.77	Sidewalk	\$360,000
	Burris-2	Burris Lane	Green Prairie Lane to Pine Country Lane	0.42	Sidewalk	\$250,000
	Burris-3	Burris Lane	Pine Country Lane to Koch Field Road	0.49	Roadway connection	\$1,230,000
	Campbell-1	Campbell Avenue	US 89 to USFS trailhead	1.09	Equestrian and pedestrian path	\$135,000
	Campbell-2	Campbell Avenue	Campbell Avenue West Trailhead	N/A	Trailhead improvements	\$110,000
	Neptune-1	Neptune Drive	Skeet Drive to Stardust Trail	0.71	Roadway improvements Paved shared-use path Equestrian path	\$905,000
	Neptune -3	Neptune/Skeet	Neptune Drive/ Skeet Drive Intersection to U.S. Forest Service Boundary	0.5	Equestrian/pedestrian path on potentially existing easement	\$75,000



**Table 9 – Phase 2 Recommended Projects (continued)**

Phase	Project Name	Street	Street Segment	Distance (miles)	Project Description	Cost
<b>PHASE 2 PROJECTS (Continued)</b>	Rio Rancho-1	Rio Rancho Road /April Drive	Townsend-Winona to Musket Trail /Autumn Drive	1.24	Paved shoulder Equestrian and pedestrian path	\$280,000
		Stardust Trail	Musket Trail to Yancey Lane		Pedestrian crossing	
	Silver Saddle-2	Silver Saddle Road	Koch Field Road to-Stardust Trail	0.72	Paved shoulder Equestrian path Paved shared-use path	\$375,000
	Skeet-1	Skeet Drive	Silver Saddle Road to Neptune Drive	0.45	Paved shared-use path Equestrian path	\$220,000
	Stardust-2	Stardust Trail	Yancey Lane to Deville Lane/ McGee Road	1.48	Paved shoulder Equestrian and pedestrian path	\$345,000
	Townsend-Winona-3	Townsend-Winona Road	Koch Field Road to Slayton Ranch Road	2.72	Paved shared-use path Equestrian path Pedestrian crossing	\$1,060,000
<b>TOTAL PHASE 2 PROJECTS</b>				<b>10.59</b>	<b>-</b>	<b>\$5,345,000</b>



**Table 10 – Phase 3 Recommended Projects**

Phase	Project Name	Street	Street Segment	Distance (miles)	Project Description	Cost
<b>PHASE 3 PROJECTS</b>	Neptune-2	Neptune Drive	Stardust Trail to Slayton Ranch Road	0.97	Paved shared-use path Equestrian path	\$370,000
	Slayton Ranch-1	Slayton Ranch Road	Townsend -Winona Road to Carl Road	0.80	Paved shoulder Equestrian and pedestrian path Pedestrian crossing.	\$220,000
	Slayton Ranch-2	Slayton Ranch Road	Carl Road to Grider Road	1.17	Paved shoulder Equestrian and pedestrian path	\$320,000
	Slayton Ranch-3	Slayton Ranch Road	Grider Road to Neptune Drive	0.86	Paved shoulder Equestrian and pedestrian path	\$245,000
	Stardust-1	Stardust Trail	Deville Lane/ McGee Road to cul-de-sac at northern terminus	0.52	Paved shoulder Equestrian and pedestrian path	\$225,000
	Townsend-Winona-4	Townsend-Winona Road	Slayton Ranch Road to Leupp Road	2.85	Paved shared-use path Equestrian path	\$1,090,000
	Townsend-Winona-5	Townsend-Winona Road	Leupp Road to Jobe Road; consider extending the pathways east to Winona/I-40. The existing bridge on Townsend-Winona Road that connects to I-40 presents a design constraint. Alternative alignments will be required. A logical terminus for the pathway needs to be identified.	1.99	Paved shared-use path Equestrian path	\$675,000
	US 89-5	US 89	Campbell Ave and/or Copeland Ave	-	Pedestrian and equestrian crossings	See Note No. 1.





**Table 10 – Phase 3 Recommended Projects (continued)**

Phase	Project Name	Street	Street Segment	Distance (miles)	Project Description	Cost
<b>PHASE 3 PROJECTS (Continued)</b>	Yancey-1	Yancey Lane	Koch Field Road to Stardust Trail	1.07	Shoulder striping/widening	\$255,000
	Picture Canyon Trail	Off-Street Pathway;	City of Flagstaff limits to Townsend-Winona Road, approximately along Rain Valley Road / FR 510E or Rio de Flag floodplain	0.3 (County portion)	Paved or soft shared-use path	See Note 2.
<b>TOTAL PHASE 3 PROJECTS MILES OF PATHWAYS AND COST</b>				10.53	-	\$3,400,000

Notes:

1. Project US 89-5 has not been developed sufficiently to develop planning-level costs. Alternatives range from crossings under US 89 to crossings over US 89 that are designed to accommodate pedestrians and unmounted equestrians. Each of these alternatives is likely to cost several million dollars.
2. Picture Canyon trail has not been developed sufficiently to develop planning-level costs. The majority of the trail lies within the City of Flagstaff. Collaboration with City of Flagstaff and the Arizona State Land Department is required.

**Table 11 – Summary of Costs by Phase**

Phase	Distance (miles)	Cost
Phase I	29.75	\$5,345,000
Phase II	10.59	\$5,345,000
Phase III	10.53	\$3,400,000
<b>TOTAL ALL PHASES</b>	50.87	\$14,090,000



## 4.9 Transit Service

An unmet need in the Doney Park area is the provision of fixed route and express bus service. *The Transportation Plan for Coconino County Commuter Services (September, 2009)* presented three potential transit service scenarios for the Doney Park area that are shown in **Figure 9**. These are described as follows:

- Scenario A – Express bus service on US 89 and Silver Saddle Road (to Koch Field Road).
- Scenario B – Express bus service on US 89 to Campbell Avenue and on Silver Saddle Road (to Koch Field Road).
- Scenario C – Fixed route bus service on US 89, Silver Saddle Road, Koch Field Road, and Townsend-Winona Road.

Park-and-ride stops (these varied depending on the specific transit alternative) were suggested at:

- US 89 / Burris Lane
- US 89 / Silver Saddle Road (at the Country Store)
- US 89 / Campbell Avenue
- Silver Saddle Road / Koch Field Road. Suggestions by the public were east of Cromer Elementary School (a park-and-ride lot could also serve as overflow parking for the school) and at Mary's Drive
- Townsend/Winona Road/ Koch Field Road (possibly at the Calvary Bible Church lot)

It is possible that potential park-and-ride lot sites could be designated as vanpool sites, prior to the start of transit service. Many of the public open house participants were supportive of extending public transit to the study area, and support was received on all the alternatives noted above.

Transit needs, as identified by the stakeholders and the public, will be forwarded to NAIPTA for their consideration for implementation as funding becomes available.

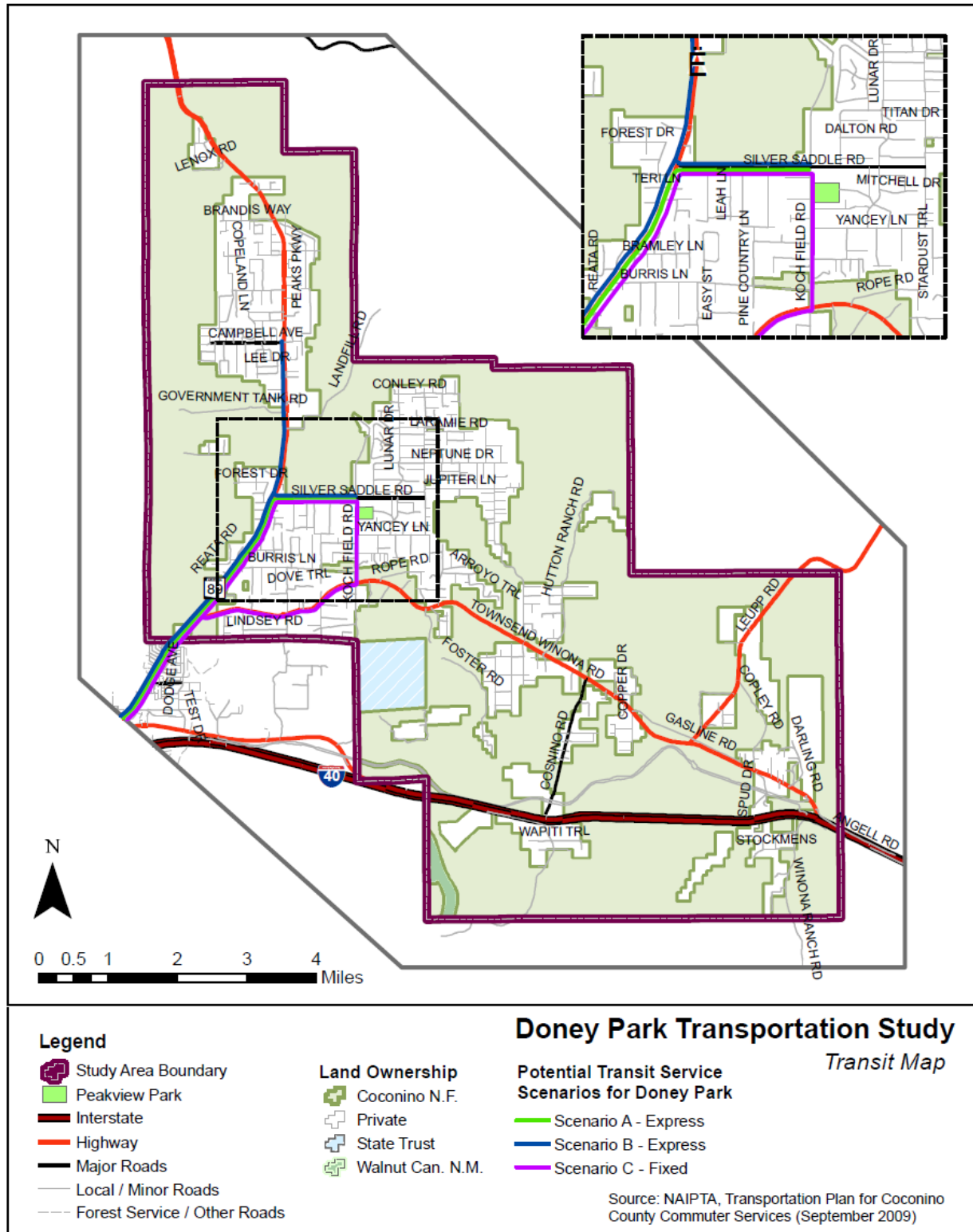

**Figure 9 – Transit Alternatives**



## 5 IMPLEMENTATION REVENUE SOURCES

This chapter describes potential funding and assistance programs for shared-use paths, bike lanes, and sidewalks.

### 5.1 *Transportation Enhancement (TE) Grant Funding*

Transportation Enhancement (TE) Grant Funding, provided by the FHWA, offers funding opportunities for 12 eligible activities related to surface transportation. Although anyone can apply, interested applicants must be sponsored by a federal, state, tribal, or local government. All local projects require a minimum 5.7% hard cash match. Projects are selected through a competitive process. Proposed projects must qualify on at least one of the following activities eligible for TE funding:

- Provision of facilities for pedestrians and bicycles.
- Provision of safety and educational activities for pedestrians and bicyclists.
- Development of scenic or historic highway programs.
- Development of landscaping and other scenic beautification.
- Work on historic preservation that has a strong surface transportation link and results in a project that retains its National Register of Historic Places eligibility.
- Rehabilitation of historic transportation buildings, structures, or facilities.
- Preservation of abandoned railway corridors, including the conversion to pedestrian or bicycle trails.
- Control and removal of outdoor advertising.
- Planning and archeological research related to surface transportation routes.
- Environmental mitigation to address water pollution due to highway runoff or reduce vehicle-caused wildlife mortality while maintaining habitat connectivity.
- Establishment of transportation museums.

Further information about the TE grant program is available at: [http://www.azdot.gov/highways/SWProjMgmt/enhancement\\_scenic/enhancement/Index.asp](http://www.azdot.gov/highways/SWProjMgmt/enhancement_scenic/enhancement/Index.asp) (accessed on March 9, 2011).

### 5.2 *Safe Routes to School Program*

The Safe Routes to School (SRTS) program was created by the U.S. Congress to address the growing epidemic of childhood obesity and diabetes. The program provides reimbursable funds for elementary/middle schools to implement projects to encourage children to walk and bicycle to school.

Interested applicants for SRTS funding are required to submit a project application. Separate applications are required for each of the SRTS funding sources:

- Infrastructure Projects
- Non-Infrastructure Projects
- Materials and Regional Support Program



- Planning Assistance Program

No matching funds are allowed or permitted by the SRTS programs. Further information about the program is provided at:

[http://www.azdot.gov/Highways/swprojmgmt/Enhancement\\_Scenic/saferoutes/AboutIndex.asp](http://www.azdot.gov/Highways/swprojmgmt/Enhancement_Scenic/saferoutes/AboutIndex.asp)

(accessed on March 9, 2011).

### **5.3 Use of Federal Funds for Equestrian Trails**

FHWA states the following as it relates to the utilization of federal funding sources for equestrian trails ([http://www.fhwa.dot.gov/environment/bikeped/allow\\_uses\\_eqnm.htm](http://www.fhwa.dot.gov/environment/bikeped/allow_uses_eqnm.htm)):

Equestrian and other nonmotorized recreational use may be allowed on shared-use paths and trails that use Federal-aid transportation funds. Federal transportation laws and regulations do *not* prohibit equestrians, in-line skaters, skateboarders, cross country skiers, snowshoe users, or other nonmotorized users on shared-use paths or trails. States or local managers may choose to prohibit these uses, but it is a State or local determination, and not a Federal requirement. Various design options may allow equestrian use, such as providing both a paved path and an unpaved path within the same right-of-way.

### **5.4 Coconino Parks and Open Space Program**

In 2002, Coconino County voters approved a County sales tax of one-eighth of one-cent for the Coconino Parks and Open Space Program (CPOS). The tax raises \$33 million over an estimated 12-year period. The sales tax initiative identified a list of specific parks, open space, and trails projects throughout the County for which these funds would be allocated. CPOS projects identified within the Doney Park planning area include improvements to Peaks View County Park and the proposed Timberline Trail. The Board of Supervisors may redirect CPOS funds only for projects on the voter-approved project list identified in the initiative or for projects that are directly related to implementation of those projects. After the \$33 million is expended, the tax automatically expires unless reauthorized by County voters. Should reauthorization occur by a future vote, it is possible that trails projects proposed in this study could be included in a future CPOS project list. At the time of the completion of this study, the Board of Supervisors has made no decision about referring a possible reauthorization of the tax to the voters and there is no guarantee of a future reauthorization or that CPOS funds would be allocated for projects in this study.

### **5.5 Federal Recreational Trails Program**

The Recreational Trails Program (RTP) provides funds to states to develop and maintain recreational trails and trail-related facilities for both nonmotorized and motorized recreational trail uses. Within Arizona, this program is administered by the Arizona State Parks Board. State Parks receives its yearly allocation through an agreement with ADOT, who draws the money down through their account with the FHWA – Arizona Division. FHWA provides guidance for the RTP and oversees all procedures, including review of National Environmental Policy Act (NEPA) requirements. Arizona currently receives approximately \$1.6 million per year. Part of the RTP funds is available for motorized trails projects through competitive grants, and part of



the funds is available for non-motorized trail purposes. The non-motorized trail funding is through the Arizona State Parks RTP Trail Maintenance Program, which funding recipients must apply for each fiscal year. The State Parks RTP Trail Maintenance Program requires recipients to match 10% of total project costs, either with in-kind contributions or dollars.

Eligible work is the efforts of trail crew(s) and project sponsor staff or volunteers to perform the following tasks:

- Tread maintenance (grading tread, slough and slide removal, slump repair, surface replacement with similar material).
- Clearing of the pathway (brush removal, hazard tree removal, litter, backslope grooming).
- Drainage (cleaning and repairing structures, culverts, underdrains, water bars, grade dips and drainage ditches).
- Replacing or repairing existing fencing, guardrails, berms, and retaining walls with similar materials.
- Structure maintenance (bridge and dam rehabilitation).
- Repairing or replacing existing signage, kiosks, and markers with similar material.
- Trail reroutes or realignment beyond five feet of each side of an existing trail surface, construction of connector trails, and any work that does not take place on the existing trail, which is performed with appropriate NEPA review and approval; however, “new trail” construction is limited to short segments.

Requests are limited to a minimum of \$10,000 and maximum of \$40,000. More information about the program is available at <http://www.pr.state.az.us/trails/index.html>

## ***5.6 National Park Service Rivers, Trails, and Conservation Assistance Program***

The Rivers, Trails, and Conservation Assistance (RTCA) program is the community assistance branch of the National Park Service. RTCA staff work collaboratively, by invitation, to assist interested partners in developing trails and greenways as well as preserving natural areas and conserving rivers. RTCA does not award monetary grants or loans. Instead, RTCA supplies a staff person with experience in community-based outdoor recreation and conservation to work with partners. If funding is necessary to achieve project goals, RTCA can often assist partners in identifying and securing sources of financial assistance.



## 6 MAINTENANCE

Pathway maintenance costs and operations and maintenance standards are important considerations after the trails are constructed. Maintenance costs should be considered prior to any pathway construction. Funding for routine maintenance should be committed, as well as purchase of equipment that may be needed in order to maintain the pathway system.

### 6.1 Maintenance Activities

The American Trails Association provides a list of typical trail maintenance activities (accessed on April 19, 2011, at:

<http://www.americantrails.org/resources/ManageMaintain/MaintCheck.html>

#### **Maintenance to be performed on a continuous, scheduled basis:**

- Trails safety inspections – e.g., condition of railings, bridges, and trail surfaces, and proper and adequate signage
- Trail sweeping
- Trash removal
- Tree and shrub pruning
- Mowing of vegetation
- Scheduling maintenance tasks – dictated by trail use, location, and design

#### **Maintenance to be performed on an irregular or as-needed basis:**

- Trail repair – Repair of asphalt or concrete trails will be closely tied to the inspection schedule. Prioritization of repairs is part of the process.
- Trail replacement – These factors include the age of the trail and the money available for replacement.
- Snow and ice removal.
- Weed control.
- Trail edging – Trail edging maintains trail width and improves drainage.
- Trail drainage control – In places where low spots on the trail catch water, trail surfaces should be raised or drains built to carry away water.
- Trail signage – Trail signs fall into two categories: safety and information.
- Revegetation – Areas adjacent to trails that have been disturbed for any reason should be revegetated to minimize erosion.
- Habitat enhancement and control – Habitat enhancement is achieved by planting vegetation along trails, mainly trees and shrubs.
- Public awareness.
- Volunteer coordination – Sources of volunteers include Boy Scouts, school groups, church groups, trail users, or court workers. Implementation of an "Adopt-a-Trail" program should be considered.



- Records – Accurate logs can be kept on items such as daily activities, hazards found and action taken, maintenance needed and performed, surveys of trail usage, etc.
- Graffiti control.
- Mapping.
- Coordination with other agencies.
- Education and interpretation.
- Law enforcement.
- Proper training of employees.

Snow removal of pathways will also need to be addressed. A failure to remove snow within a reasonable period following a storm will prevent users from enjoying the safety benefits that the pathway provides. This will require Coconino County to purchase equipment capable of traversing the eight-foot paved pathway surface. It is anticipated that snow would not be removed from the soft surface pathways, as equipment may have the potential to damage the pathway under snowy and icy conditions.

## 6.2 Maintenance Costs

Ongoing trail and pathway maintenance costs must be considered as planning and design continue. According to an article entitled *Operations, Maintenance and Stewardship 101 (Trail Tracks, Fall, 2005)* (accessed on April 19, 2011, at <http://www.americantrails.org/resources/ManageMaintain/searnsmaint101.html>), operations and maintenance costs vary substantially depending on the facility, climate, and complexity of the system. Potential maintenance costs for urban trail systems on an annual per-mile cost may range from \$2,500 to \$10,000. Different sources of revenue may be identified including:

- General fund allocations;
- Revenue from right-of-way leases such as cable use, cell phone towers;
- Participation and partnering with stakeholders such as a flood control agency, streets department, or homeowners associations;
- Recruiting volunteers, youth, and adopt-a-trail participants and sponsors;
- Creation of an endowment from philanthropic or other sources to generate ongoing revenue.
- Improvement districts: The State of Arizona authorizes the creation of improvement districts in unincorporated areas (areas located outside city limits) for the purposes of making local improvements such as paving, re-paving, grading, re-grading, or to improve all, or any portion of, one or more streets in a proposed district. Improvement districts could be established to fund construction and maintenance of the pathway network.





## APPENDIX A – PROJECT INFORMATION SHEETS



**Project Information Sheet 1 – Burriss Lane 1**

<b>Project No.</b>	Burriss-1
<b>Project Name</b>	Burriss Lane, US 89 to Green Prairie Lane, Sidewalk Construction
<b>Project Length</b>	0.77 miles
<b>Project Objective</b>	Construct curb, gutter, and 5 foot-wide attached sidewalks on the north side of the street
<b>Project Need / Community Benefit</b>	This project will improve pedestrian safety. Currently, walkers from residences and mobile home parks must walk in the street. Drainage channel and physical constraints make a separated shared-use path prohibitive.
<b>2011 Total Cost Estimate</b>	\$360,000
<b>A. Scoping</b>	\$50,000
<b>B. Design (30%, 60%, 95-100%)</b>	\$55,000
<b>C. Construction</b>	\$255,000
<b>Comments</b>	A sidewalk is proposed on the north side of the street because there are drainage ditches on the south side. The design will need to consider the driveways located on the north side of the street. Travel lane width reduction should be considered to minimize impacts to property owners.



Burriss Lane looking west towards US 89



**Project Information Sheet 2 – Burris-2**

<b>Project No.</b>	Burris-2
<b>Project Name</b>	Burris Lane, Green Prairie Lane to Pine Country Lane, Sidewalk Construction
<b>Project Length</b>	0.42 miles
<b>Project Objective</b>	Construct curb, gutter, and 5'-wide attached sidewalks on the north side of the street.
<b>Project Need / Community Benefit</b>	This project will improve pedestrian safety. Currently, walkers from residences and mobile home parks must walk in the street.
<b>2011 Total Cost Estimate</b>	\$250,000
<b>A. Scoping</b>	\$40,000
<b>B. Design (30%, 60%, 95-100%)</b>	\$50,000
<b>C. Construction</b>	\$160,000
<b>Comments</b>	A sidewalk is proposed on the north side of the street because there are drainage ditches on the south side. A potential design issue concerns culverts crossing each driveway on the north side of the street.



Burris Lane, east of Green Prairie Lane, looking west

**Project Information Sheet 3 – Burris-3**

<b>Project No.</b>	Burris-3
<b>Project Name</b>	Burris Lane, Pine Country Lane to Koch Field Road, New Roadway Connection to Koch Field Road
<b>Project Length</b>	0.49 miles
<b>Project Objective</b>	Extend Burris Lane to Koch Field Road; roadway improvements should include pedestrian and equestrian facilities; will require crossing of major drainage; will require easement from U.S. Forest Service.
<b>Project Need / Community Benefit</b>	A roadway connection will provide a link between Burris Lane and Koch Field Road.
<b>2011 Total Cost Estimate*</b> <i>*Approximate planning estimate only. Additional analysis required to develop cost estimate</i>	\$1,230,000
<b>A. Scoping</b>	\$110,000
<b>B. Design (30%, 60%, 95-100%)</b>	\$265,000
<b>C. Construction</b>	\$855,000
<b>Comments</b>	A ravine in this area will need a bridge or earthen embankment. Ownership of access in this area needs to be determined. Coordination with U.S. Forest Service will be required.
	
<p>Burris Lane, east of Pine Country Lane at ravine</p>	



**Project Information Sheet 4 – Campbell-1**

<b>Project No.</b>	Campbell-1
<b>Project Name</b>	Campbell Avenue, US 89 to USFS trailhead, Shared-use path Reconstruction
<b>Project Length</b>	1.09 miles
<b>Project Objective</b>	Reconstruct existing pathway to 8'-wide path on the north side of the street. Construct low railing fence between pathway and vehicular lanes to provide physical barrier from vehicular travel lanes. Path will be constructed of natural materials suitable to both equestrians and pedestrians. There is insufficient right-of-way along Campbell Avenue to construct separate pathways for pedestrians and equestrians. Stakeholders suggested that Campbell Avenue drainage way design could incorporate pedestrian and equestrian pathways.
<b>Project Need / Community Benefit</b>	The condition of the existing dirt path is poor. This project will provide a link between US 89 and the Coconino National Forest.
<b>2011 Total Cost Estimate</b>	\$135,000
<b>A. Scoping</b>	\$35,000
<b>B. Design (30%, 60%, 95-100%)</b>	\$25,000
<b>C. Construction</b>	\$75,000
<b>Comments</b>	There is an existing 10' paved path between US 89 and Zady Lane. Improvements to parking area and trailhead will require coordination with the U.S. Forest Service.



Campbell Avenue at Lupine Lane, looking east

**Project Information Sheet 5 – Campbell - 2**

<b>Project No.</b>	Campbell-2
<b>Project Name</b>	Campbell Avenue West Trailhead / Parking Improvement Project
<b>Project Length</b>	N/A
<b>Project Objective</b>	Relocate the existing trailhead to the west to U.S. Forest Service land; reconstruct and expand the trailhead area to provide parking, and trailhead amenities.
<b>Project Need / Community Benefit</b>	The parking area at the trailhead is small and could be moved closer to the trail. There is limited signage.
<b>2011 Total Cost Estimate</b>	\$110,000
<b>A. Scoping</b>	\$30,000
<b>B. Design (30%, 60%, 95-100%)</b>	\$20,000
<b>C. Construction</b>	\$60,000
<b>Comments</b>	Preserve large trees at the existing trailhead. Parking area will require coordination with U.S. Forest Service



Trailhead gate at west end of Campbell Avenue

**Project Information Sheet 6 – Cosnino-1**

<b>Project No.</b>	Cosnino-1
<b>Project Name</b>	Cosnino Road, Townsend-Winona Road to Roan Road, Shoulder Improvements and Pathway
<b>Project Length</b>	0.94 miles
<b>Project Objective</b>	<ul style="list-style-type: none"> <li>• Restripe existing street to 10' travel lanes and 4' paved shoulder; add pavement as necessary to construct 4' paved shoulder.</li> <li>• Construct a 6' equestrian and pedestrian path on the west side of street. Path will consist of natural materials suitable to equestrians, but should also provide sufficient stability for pedestrians.</li> <li>• Evaluate need for marked pedestrian crossing/pedestrian crossing beacon at Townsend-Winona Road/Cosnino Road intersection. Roundabout proposed at this intersection in the Townsend-Winona Corridor Study.</li> </ul>
<b>Project Need / Community Benefit</b>	This path will form part of a continuous path along Cosnino Road between Townsend-Winona Road and the Arizona Trail.
<b>2011 Total Cost Estimate</b>	\$230,000
<b>A. Scoping</b>	\$40,000
<b>B. Design (30%, 60%, 95 -100%)</b>	\$45,000
<b>C. Construction</b>	\$145,000
<b>Comments</b>	A soft path fits the rural nature and high equestrian use of the area.
	
<p>Cosnino Road, looking south</p>	



**Project Information Sheet 7 – Cosnino-2**

<b>Project No.</b>	Cosnino-2
<b>Project Name</b>	Cosnino Road, Roan Road to Arizona Trail, Shoulder Improvements and Pathway
<b>Project Length</b>	0.9 miles
<b>Project Objective</b>	<ul style="list-style-type: none"> <li>• Restripe existing street to 10' travel lanes and 4' paved shoulder along Cosnino Road; add pavement if necessary to construct 4' paved shoulder.</li> <li>• Construct a 6' equestrian path on the west side of street. Path will consist of natural materials suitable to equestrians, but should also provide sufficient stability for pedestrians. Connect path through U.S. National Forest lands to the Arizona Trail, which crosses under the BNSF Railroad tracks southwest of Cosnino.</li> </ul>
<b>Project Need / Community Benefit</b>	A shared-use path on this road will provide better access for equestrians and pedestrians on this route. Currently the shoulders are graded. Paved shoulders will improve conditions for bicyclists.
<b>2011 Total Cost Estimate</b>	\$255,000
<b>A. Scoping</b>	\$45,000
<b>B. Design (30%, 60%, 95-100%)</b>	\$50,000
<b>C. Construction</b>	\$160,000
<b>Comments</b>	A soft path fits the rural nature of the area.
	
<p>Arizona Trail, located ½ miles west of Cosnino Road</p>	





**Project Information Sheet 8 – Cosnino-3**

<b>Project No.</b>	Cosnino-3
<b>Project Name</b>	Traffic calming on Cosnino Road, within the community of Cosnino
<b>Project Length</b>	N/A
<b>Project Objective</b>	Evaluate potential traffic calming alternatives to slow vehicles on Cosnino Road. Traffic circles may be considered.  Traffic calming may be considered between Palomino Drive and Buckskin Court, a distance of approximately 2,000 feet.
<b>Project Need / Community Benefit</b>	Stakeholders stated that vehicle speeds are high on this residential street that connects to I-40. Traffic calming will slow vehicles improving the safety and comfort of bicyclists, pedestrians, and equestrians.
<b>2011 Total Cost Estimate</b>	<p>Alternatives for traffic calming include traffic circles or median islands. Traffic circles would consist of a raised center island in the center of the intersection that is approximately 20' to 40' in diameter.</p> <p>Traffic circles can be constructed for as little as \$2,000 to \$5,000 depending upon the size and degree of landscaping.</p> <p>An estimate of \$25,000 is assumed for planning purposes.</p>
<b>A. Scoping</b>	
<b>B. Design (30%, 60%, 95-100%)</b>	
<b>C. Construction</b>	
<b>Comments</b>	Residents of Cosnino identified speeding as a significant concern. Cosnino provides direct access to I-40.



**Project Information Sheet 9 – Koch Field-1**

<b>Project No.</b>	Koch Field-1
<b>Project Name</b>	Koch Field Road, Townsend-Winona Road to Kavanaugh Way /Anaya Road, Pathway and Paved Shoulder
<b>Project Length</b>	0.42 miles
<b>Project Objective</b>	<ul style="list-style-type: none"> <li>• Restripe existing street to 10' travel lanes and 4' paved shoulder; add pavement if necessary to construct 4' paved shoulder. Narrower travel lanes also serve to slow vehicular traffic. Paved shoulders may be designated as bicycle lanes.</li> <li>• Construct an 8' paved path on the east side of the street; new path would connect to the existing path on Koch Field Road. Primary user of pathway is pedestrians and bicyclists traveling at low speeds.</li> <li>• Construct a 6' equestrian path on the west side of street (opposite paved path). Equestrian crossing of drainage would be at-grade.</li> <li>• Evaluate need for marked pedestrian crossing/ pedestrian crossing beacon at Koch Field Road/ Townsend-Winona Road intersection. A roundabout is proposed at this intersection in the Townsend-Winona Corridor Study.</li> </ul>
<b>Project Need / Community Benefit</b>	Extending shared-use path will provide connectivity between the Townsend-Winona Area and Peaks View Park. It will complete a missing link in this popular shared-use path.
<b>2011 Total Cost Estimate</b>	\$265,000
<b>A. Scoping</b>	\$45,000
<b>B. Design (30%, 60%, 95-100%)</b>	\$50,000
<b>C. Construction</b>	\$170,000
<b>Comments</b>	The narrow bridge crossing the Rio de Flag south of Kavanaugh/Anaya Road is a constraint to pathway construction. Bridge culvert will require extension. This project may meet requirements for Safe Routes to School funding.

**Project Information Sheet 10 – Koch Field-2**

<b>Project No.</b>	Koch Field-2
<b>Project Name</b>	Kavanaugh Way /Anaya Road to Silver Saddle Road, Pathway and Paved Shoulder
<b>Project Length</b>	0.8 miles
<b>Project Objective</b>	<ul style="list-style-type: none"> <li>• Restripe existing street to 10' travel lanes and 4' paved shoulder; add pavement if necessary to construct 4' paved shoulder.</li> <li>• Construct a 6' equestrian path on the west side of street (opposite of the existing paved path). Path will consist of natural materials suitable to equestrians.</li> </ul>
<b>Project Need / Community Benefit</b>	There is an existing paved pathway on the east side of Koch Field Road. A paved shoulder and equestrian path will complete a missing link between the Townsend-Winona area and Peaks View Park.
<b>2011 Total Cost Estimate</b>	\$235,000
<b>A. Scoping</b>	\$40,000
<b>B. Design (30%, 60%, 95-100%)</b>	\$45,000
<b>C. Construction</b>	\$150,000
<b>Comments</b>	The narrow bridge crossing the Rio de Flag south of Kavanaugh/Anaya Road is a constraint to pathway construction. Bridge culvert will require extension. This project may be eligible for Safe Routes to School funding.



West side of the Koch Field Road bridge south of Kavanaugh / Anaya Road

**Project Information Sheet 11 – Leupp-1**

<b>Project No.</b>	Leupp-1
<b>Project Name</b>	Leupp Road, Townsend-Winona Road to U.S. Forest Service Road 244 (northern project limits), Bike Route Signing
<b>Project Length</b>	4.92 miles
<b>Project Objective</b>	Install bike route signing.
<b>Project Need / Community Benefit</b>	Providing signed bike lanes will raise motorist awareness of bicycles on this popular recreational bike route that links the Townsend-Winona area with Coconino National Forest lands.
<b>2011 Cost Estimate</b>	\$40,000
<b>A. Scoping</b>	\$15,000 (may not be necessary if local funds are utilized, or streamlined environmental process is followed)
<b>B. Design (30%, 60%, 95-100%)</b>	\$5,000
<b>C. Construction</b>	\$20,000
<b>Comments</b>	Some shoulder improvements may be required on a spot location basis. This should be considered during any future pavement preservation projects. AASHTO recommends a minimum 5' bicycle lane.



Leupp Road, at MP 433



**Project Information Sheet 12 – Neptune-1**

<b>Project No.</b>	Neptune-1
<b>Project Name</b>	Neptune Drive, Skeet Drive to Stardust Trail Path
<b>Project Length</b>	0.7 miles
<b>Project Objective</b>	<ul style="list-style-type: none"> <li>Roadway between Lunar Drive and Stardust Trail is currently not maintained by the County. Improve roadway to minimum standards. Consider process to adopt unmaintained roadway into county maintenance system.</li> <li>Construct an 8' paved path on the north side of the street; primary users of the pathway are pedestrians, strollers, and low-speed bicyclists.</li> <li>Construct a 6'-wide equestrian path on the south side of street (opposite paved path). Path will consist of natural materials suitable to equestrians.</li> </ul>
<b>Project Need / Community Benefit</b>	A shared-use path on Neptune Drive, between Stardust Trail and Skeet Drive, would provide safer access for students walking to and from Cromer Elementary School
<b>2011 Total Cost Estimate*</b> <i>*Approximate planning estimate only. Additional analysis required to develop cost estimate</i>	\$905,000
<b>A. Scoping / Survey / Enviro.</b>	\$85,000
<b>B. Design (30%, 60%, 95-100%)</b>	\$195,000
<b>C. Construction</b>	\$625,000
<b>Comments</b>	<p>Neptune Drive is unpaved between Lunar Drive and Stardust Trail. Neptune Drive from Stardust Trail to Lunar Drive is constructed on a public easement but is not maintained by the county.</p> <p>There are opportunities for rest nodes at the intersections of Neptune / Lunar and Neptune / Skeet.</p>

**Project Information Sheet 13 – Neptune-2**

<b>Project No.</b>	Neptune-2
<b>Project Name</b>	Neptune Drive, Stardust Trail to Slayton Ranch Road Pathway
<b>Project Length</b>	0.97 miles
<b>Project Objective</b>	<ul style="list-style-type: none"> <li>• Improve existing informal unpaved pathway on the north side of the street to 8' paved path; primary users of pathway are pedestrians, strollers, and low-speed bicyclists.</li> <li>• Construct a 6' equestrian path on the south side of street (opposite paved path). Path will consist of natural materials suitable to equestrians.</li> </ul>
<b>Project Need / Community Benefit</b>	A pathway will provide a comfortable location for pedestrians and equestrians; is within vicinity of Cromer Elementary School
<b>2011 Total Cost Estimate</b>	\$370,000
<b>A. Scoping</b>	\$50,000
<b>B. Design (30%, 60%, 95-100%)</b>	\$75,000
<b>C. Construction</b>	\$245,000
<b>Comments</b>	N/A



Neptune Drive at Slayton Ranch Road



**Project Information Sheet 14 – Neptune-3**

<b>Project No.</b>	Neptune-3
<b>Project Name</b>	Neptune Drive/Skeet Drive Off-street Pathway to U.S. Forest Service on Easement
<b>Project Length</b>	0.5 miles
<b>Project Objective</b>	Construct an unpaved equestrian path/pedestrian path from the intersection of Neptune Drive/Skeet Drive to U.S. Forest Service access point.
<b>Project Need / Community Benefit</b>	An opportunity may exist to improve existing social trail on a potential existing easement that originates at the northwest corner of the intersection of Neptune Drive at Skeet Drive, and extends west (parallel to Neptune) between two properties to the U.S. Forest Service fence line, then heads north parallel to the U.S. Forest Service property boundary to an un-gated opening. The pathway would be constructed of natural materials suitable to equestrians. There is insufficient space for divided equestrian/ pedestrian treads.
<b>2011 Total Cost Estimate</b>	\$95,000
<b>A. Scoping</b>	\$25,000
<b>B. Design (30%, 60%, 95-100%)</b>	\$15,000
<b>C. Construction</b>	\$55,000
<b>Comments</b>	N/A



**Project Information Sheet 15 – Picture Canyon Trail**

<b>Project No.</b>	Picture Canyon Trail-1
<b>Project Name</b>	Picture Canyon Trail
<b>Project Length</b>	0.3 miles (Coconino County portion)
<b>Project Objective</b>	Construct Picture Canyon Trail to connect to Townsend-Winona Road. Precise location of the Picture Canyon trail is not yet determined. Options have been proposed along Rain Valley Road/FR 510E and the Rio de Flag Floodplain. Surface material is to be determined; surface material should be suitable to equestrians.
<b>Project Need / Community Benefit</b>	Construction of the Picture Canyon Trail, Koch Field-1, and a portion of Townsend-Winona-2 would complete a continuous trail from Cromer Elementary School to downtown Flagstaff; the last one-third mile of the trail is outside of City limits.
<b>2011 Total Cost Estimate</b>	To be determined. Only the last 1/3 of a mile lies outside of City limits, in Coconino County. This last segment would be constructed in conjunction with the remainder of the trail within City limits. Collaboration between City and County is required.
<b>A. Scoping</b>	
<b>B. Design (30%, 60%, 95-100%)</b>	
<b>C. Construction</b>	
<b>Comments</b>	N/A





**Project Information Sheet 16 – Rio Rancho-1**

<b>Project No.</b>	Rio Rancho-1
<b>Project Name</b>	Rio Rancho Road / April Road / Stardust Trail Paved Shoulder and Pathway
<b>Project Length</b>	1.24 miles
<b>Project Objective</b>	<ul style="list-style-type: none"> <li>• Stripe existing street segments to 10' travel lanes and 4' paved shoulder. New roadway (programmed by Coconino County) should include paved shoulder.</li> <li>• Construct a 6' equestrian and pedestrian path on the east side of street; path will consist of natural materials suitable to equestrians, but also should provide sufficient stability for pedestrians. New roadway (programmed by Coconino County) should include equestrian and pedestrian path.</li> <li>• Evaluate need for marked pedestrian crossing/ pedestrian crossing beacon at Rio Rancho Road/ Townsend-Winona Road intersection. Roundabout proposed at this intersection in the Townsend-Winona Corridor Study.</li> </ul>
<b>Project Need / Community Benefit</b>	This project will improve north-south connectivity.
<b>2011 Total Cost Estimate</b>	\$280,000
<b>A. Scoping</b>	\$45,000
<b>B. Design (30%, 60%, 95-100%)</b>	\$55,000
<b>C. Construction</b>	\$180,000
<b>Comments</b>	<p>This project consists of two segments:</p> <ul style="list-style-type: none"> <li>• Rio Rancho Road, Townsend-Winona to east Thunder Creek Road (in curbed sections, path attached to the curb on the east side of the street). Pathway may need to be narrowed to 6' in this section; soft path may not be feasible within existing R/W.</li> <li>• Musket Trail/Autumn Drive to Stardust Trail: Coordinate path with roadway improvement project.</li> </ul> <p>May require culvert extension to accommodate pedestrians.</p>



**Project Information Sheet 17 – Silver Saddle-1**

<b>Project No.</b>	Silver Saddle-1
<b>Project Name</b>	Silver Saddle Road, US 89 to Doney Park Lane / Koch Field Road, Shared-use Path
<b>Project Length</b>	1.13 miles
<b>Project Objective</b>	<ul style="list-style-type: none"> <li>• Restripe existing street to 10' travel lanes and 4' paved shoulder; add pavement if necessary to construct 4' paved shoulder. Narrower travel lanes serve to slow vehicular traffic. Paved shoulders may be designated as bicycle lanes.</li> <li>• Construct an 8' paved path on the north of the street; path would meander through U.S. Forest Service lands where available. Primary user of pathway is pedestrians and bicyclists traveling at slower speeds.</li> <li>• Construct an equestrian path (Koch Field Road to Silver Spur Road; provides access to Old Caves Crater Trailhead): Construct a 6' equestrian path on the north side of the street, (offset as much as feasible from paved pathway; 30 feet or more is desirable). Majority of path traverses U.S. Forest Service lands; coordination with U.S. Forest Service required. Where separation is not feasible, construct a low-railing fence (if solid, 54" maximum height) between equestrian tread and pedestrian path. Equestrian path will be constructed of natural materials suitable to equestrians.</li> </ul>
<b>Project Need / Community Benefit</b>	These paths will link activity centers and the trailhead leading to Old Caves Crater Trail. Silver Saddle Road is one of the busiest streets in Doney Park. Existing shoulders are narrow.
<b>2011 Total Cost Estimate</b>	\$580,000
<b>A. Scoping</b>	\$65,000
<b>B. Design (30%, 60%, 95-100%)</b>	\$120,000
<b>C. Construction</b>	\$395,000
<b>Comments</b>	Right-of-way and easements require further investigation. The proposed soft path could widen to 6' or more through U.S. Forest Service land. Coordination required.



**Project Information Sheet 18 – Silver Saddle-2**

<b>Project No.</b>	Silver Saddle-2
<b>Project Name</b>	Silver Saddle Road, Skeet Drive to Stardust Trail Shared-use Path
<b>Project Length</b>	0.72 miles
<b>Project Objective</b>	<ul style="list-style-type: none"> <li>• Restripe existing street to 10' travel lanes and 4' paved shoulder.</li> <li>• Construct a 6' equestrian path on the north side of street; path will consist of natural materials suitable to equestrians. Note existing sidewalk on north side of the street between Koch Field Road and Skeet Drive; investigation of feasibility of equestrian path through this segment (Koch Field Road to Skeet Drive) is required.</li> <li>• Improve existing unpaved pathway on south side of the street (Skeet Drive to Stardust Trail) to 8' paved path; primary user of pathway is pedestrians, strollers, and low-speed bicyclists.</li> </ul>
<b>Project Need / Community Benefit</b>	Improving existing path will improve access for schoolchildren (existing unpaved path is located between Koch Field Road and Skeet Drive). Silver Saddle Road is one of the busiest streets in Doney Park.
<b>2011 Total Cost Estimate</b>	\$375,000
<b>A. Scoping</b>	\$50,000
<b>B. Design (30%, 60%, 95-100%)</b>	\$75,000
<b>C. Construction</b>	\$250,000
<b>Comments</b>	N/A

**Project Information Sheet 19 – Skeet-1**

<b>Project No.</b>	Skeet-1
<b>Project Name</b>	Skeet Drive, Silver Saddle Road to Neptune Drive, Shared-use Path
<b>Project Length</b>	0.45 miles
<b>Project Objective</b>	<ul style="list-style-type: none"> <li>Construct an 8' paved path on the west side of the street; primary user of pathway is pedestrians, strollers, and slow-speed bicyclists.</li> <li>Construct a 6' equestrian path on the east side of street; path will consist of natural materials suitable to equestrians.</li> </ul>
<b>Project Need / Community Benefit</b>	The provision of a multimodal path on this road would provide improved access for students walking or biking to school. Currently Skeet Drive is a north-south minor collector with limited shoulders.
<b>2011 Total Cost Estimate</b>	\$220,000
<b>A. Scoping</b>	\$40,000
<b>B. Design (30%, 60%, 95-100%)</b>	\$45,000
<b>C. Construction</b>	\$140,000
<b>Comments</b>	This path will connect to a proposed path on Neptune Drive. There is a potential for a rest node at the intersection of Skeet Drive / Neptune Drive. This project could be eligible for Safe Routes to School funding.



Skeet Drive, near Silver Saddle Road, looking north



**Project Information Sheet 20 – Slayton Ranch-1**

<b>Project No.</b>	Slayton Ranch-1
<b>Project Name</b>	Slayton Ranch Road, Townsend-Winona Road to Carl Road, Shared-use Path
<b>Project Length</b>	0.80 miles
<b>Project Objective</b>	<ul style="list-style-type: none"> <li>• Restripe existing street to 10' travel lanes and 4' paved shoulder. Existing pavement width may only allow for striping of 4' shoulder on one side of the roadway, and less than 4' on opposite side of the roadway. Striped shoulder will provide stabilized walking surface for pedestrians. White roadway stripe will define the space from motor vehicles.</li> <li>• Construct a 6' equestrian and pedestrian path on the west side of street; path will consist of natural materials suitable to equestrians, but should also provide stability for pedestrians.</li> <li>• Evaluate need for marked pedestrian crossing/ pedestrian crossing beacon at Townsend-Winona Road/ Slayton Ranch Road intersection. A roundabout is proposed at this intersection in the Townsend-Winona Corridor Study (not included in cost estimate).</li> </ul>
<b>Project Need / Community Benefit</b>	When fully developed with the other Slayton Ranch Road projects, this project supports the Doney Park Timberline Fernwood Area Plan policy that trail linkages are to be provided between the north and east sides of Doney Park to the Townsend-Winona Road corridor.
<b>2011 Total Cost Estimate</b>	\$220,000
<b>A. Scoping</b>	\$40,000
<b>B. Design (30%, 60%, 95-100%)</b>	\$40,000
<b>C. Construction</b>	\$140,000
<b>Comments</b>	A rest node could be considered near the intersection of Townsend-Winona Road and Slayton Ranch Road.



**Project Information Sheet 21 – Slayton Ranch-2**

<b>Project No.</b>	Slayton Ranch-2
<b>Project Name</b>	Slayton Ranch Road, Carl Road to Grider Road, Shared-use Path
<b>Project Length</b>	1.17 miles
<b>Project Objective</b>	<ul style="list-style-type: none"> <li>• Restripe existing street to 10' travel lanes and 4' paved shoulder. Existing pavement width may only allow for striping of 4' shoulder on one side of the roadway, and less than 4' on opposite side of the roadway. Further investigation required. Striped shoulder will provide stable walking surface for pedestrians. White roadway stripe will define the space from motor vehicles.</li> <li>• Construct a 6' equestrian and pedestrian path on the west side of street; path will consist of natural materials suitable to equestrians, but should also provide stability for pedestrians. Path will meander through U.S. Forest Service lands as available; coordination required. Coordination required with the U.S. Forest Service Logan's Crossing Wildlife Interpretive Trails. Equestrian path would connect to the proposed Logan's Crossing U.S. Forest Service trails.</li> </ul>
<b>Project Need / Community Benefit</b>	This project supports the Doney Park Timberline Fernwood Area Plan policy that trail linkages are to be provided between the north and east sides of Doney Park to the Townsend-Winona Road corridor.
<b>2011 Total Cost Estimate</b>	\$320,000
<b>A. Scoping</b>	\$45,000
<b>B. Design (30%, 60%, 95-100%)</b>	\$65,000
<b>C. Construction</b>	\$210,000
<b>Comments</b>	This proposed soft path may widen to 6' or more through U.S. Forest Service land. There are several sections of this path where physical, drainage, or right-of-way constraints will require right-of-way acquisition, or alternative configurations to be explored. Additional right-of-way may be required.



**Project Information Sheet 22 – Slayton Ranch-3**

<b>Project No.</b>	Slayton Ranch-3
<b>Project Name</b>	Slayton Ranch Road, Grider Road to Neptune Drive, Shared-use Path
<b>Project Length</b>	0.86 miles
<b>Project Objective</b>	<ul style="list-style-type: none"> <li>• Restripe existing street to 10' travel lanes and 4' paved shoulder. Existing pavement width may only allow for striping of 4' shoulder on one side of the roadway, and less than 4' on opposite side of the roadway. Further investigation required. Striped shoulder will provide stable walking surface for pedestrians. White roadway stripe will define the space from motor vehicles.</li> <li>• Construct a 6' equestrian and pedestrian path on the west side of street; path will consist of natural materials suitable to equestrians, but should also provide stability for pedestrians.</li> </ul>
<b>Project Need / Community Benefit</b>	When fully developed with the other Slayton Ranch Road projects, this project supports the Doney Park Timberline Fernwood Area Plan policy that trail linkages are to be provided between the north and east sides of Doney Park to the proposed Townsend-Winona Road corridor in the Open Spaces & Greenways Plan.
<b>2011 Total Cost Estimate</b>	\$245,000
<b>A. Scoping</b>	\$40,000
<b>B. Design (30%, 60%, 95-100%)</b>	\$50,000
<b>C. Construction</b>	\$155,000
<b>Comments</b>	There are several sections of this path where physical, drainage, or R/W constraints will require right-of-way acquisition, or alternative configurations to be explored including small segments of sidewalk. Additional right-of-way may be required.



**Project Information Sheet 23 – Stardust-1**

<b>Project No.</b>	Stardust-1
<b>Project Name</b>	Stardust Trail, northern terminus (north of Conley Road) to Deville Lane, Striped Shoulder and Pathway
<b>Project Length</b>	0.52 miles
<b>Project Objective</b>	<ul style="list-style-type: none"> <li>• Restripe existing street to 10' travel lanes and 4' paved shoulder. Striped shoulder will provide stable walking surface for pedestrians and strollers. White roadway stripe will define the space from motor vehicles.</li> <li>• Construct a 6' equestrian and pedestrian path on the east side of street; path will consist of natural materials suitable to equestrians, but also provide sufficient stability for pedestrians, strollers, and small children on bicycles.</li> </ul>
<b>Project Need / Community Benefit</b>	A paved shoulder will provide a defined area for pedestrians desiring a hard surface. Equestrian path will provide connectivity to U.S. Forest Service access point.
<b>2011 Total Cost Estimate</b>	\$225,000
<b>A. Scoping</b>	\$40,000
<b>B. Design (30%, 60%, 95-100%)</b>	\$45,000
<b>C. Construction</b>	\$140,000
<b>Comments</b>	There is access to U.S. Forest Service land at the cul-de-sac at the northern end of Stardust Trail.



Forest Service access at north end of Stardust Trail





**Project Information Sheet 24 – Stardust-2**

<b>Project No.</b>	Stardust-2
<b>Project Name</b>	Stardust Trail, Deville Lane to Yancey Lane, Striped Shoulder and Pathway
<b>Project Length</b>	1.48 miles
<b>Project Objective</b>	<ul style="list-style-type: none"> <li>• Restripe existing street to 10' travel lanes and 4' paved shoulder. Existing pavement width may only allow for striping of 4' shoulder on one side of the roadway, and less than 4' on opposite side of the roadway. Further investigation required. Striped shoulder will provide stable walking surface for pedestrians and strollers. White roadway stripe will define the space from motor vehicles.</li> <li>• Construct a 6' equestrian and pedestrian path on the east side of street; path will consist of natural materials suitable to equestrians, but should also provide sufficient stability for pedestrians. Path connects to U.S. Forest Service access point at north end of Stardust Trail. Path also connects to equestrian path on Silver Saddle which provides access to Old Caves Crater Trailhead.</li> </ul>
<b>Project Need / Community Benefit</b>	Pedestrians currently have to walk in the street.
<b>2011 Total Cost Estimate</b>	\$345,000
<b>A. Scoping</b>	\$50,000
<b>B. Design (30%, 60%, 95-100%)</b>	\$70,000
<b>C. Construction</b>	\$225,000
<b>Comments</b>	There may be drainage constraints at the southern end of the project, near Yancey Lane.



**Project Information Sheet 25 – Townsend-Winona-1**

<b>Project No.</b>	Townsend-Winona-1
<b>Project Name</b>	Townsend-Winona Road, US 89 to I-40, Bike Lanes
<b>Project Length</b>	10.0 miles
<b>Project Objective</b>	Sign and designate bicycle lanes on Townsend-Winona; Existing shoulders are generally 5' wide, but range from 4' to 6'. AASHTO recommends 5' minimum bike lane on roadways with speed limit of 50 mph or more. Provide spot improvements as needed to provide a consistent 5' shoulder. 10' shoulders are proposed as an alternative in the Final Engineering Study for Townsend-Winona Road, Jct. 89 to Jct. I-40, Leupp Road, Jct. Townsend-Winona Road, East 1-mile (June 27, 2008).
<b>Project Need / Community Benefit</b>	Shoulders are generally wide enough for designation as bicycle lanes; spot improvements may be required. There has been discussion regarding rumble strips on this corridor. If installed, rumble strips should be designed to minimize negative impacts on bicyclists. The ADOT Rumble Strip policy provides a good example.
<b>2011 Total Cost Estimate (for signing only)</b>	\$75,000 (signing only)
<b>A. Scoping</b>	\$30,000 (may not be necessary if local funds are used, or streamlined environmental process identified)
<b>B. Design (30%, 60%, 95-100%)</b>	\$10,000
<b>C. Construction</b>	\$35,000
<b>Comments</b>	Wide shoulders are proposed in the Townsend-Winona Corridor Study.



**Project Information Sheet 26 – Townsend-Winona-2**

<b>Project No.</b>	Townsend-Winona-2
<b>Project Name</b>	Townsend-Winona Road, US 89 to Koch Field Road, Shared-use Path
<b>Project Length</b>	2.46 miles
<b>Project Objective</b>	<ul style="list-style-type: none"> <li>Construct a 10' paved path on the north side of the street; primary users of pathway are pedestrians and low-speed bicyclists. Note that bicycle lanes are provided through Project Townsend-Winona 1. Connect paved shared-use path to proposed pathway on US 89.</li> <li>Construct a 6' equestrian path on the south side of the street (opposite paved path). Construct barrier (52" maximum height) between equestrian tread and vehicular lanes. Path will be constructed of natural materials suitable to equestrians. Connect equestrian path to Arizona Trail. Arizona Trail crosses under US 89 south of Townsend-Winona Road intersection.</li> </ul>
<b>Project Need / Community Benefit</b>	This road is one of the higher volume streets in the Doney Park area; a shared-use path will accommodate pedestrians, slow-speed bicyclists; equestrians are accommodated on a separated soft path. This will also connect to the future Picture Canyon Trail.
<b>2011 Total Cost Estimate</b>	\$1,060,000
<b>A. Scoping</b>	\$100,000
<b>B. Design (30%, 60%, 95-100%)</b>	\$230,000
<b>C. Construction</b>	\$730,000
<b>Comments</b>	<p>Connection of US 89 and Townsend-Winona proposed paths and the Arizona Trail is proposed at the intersection of US 89/Townsend-Winona. Path design and construction should be coordinated with planned Townsend-Winona roadway improvements (Final Engineering Study for Townsend-Winona Road, Jct. 89 to Jct. I-40, Leupp Road, Jct. Townsend-Winona Road, East 1-mile (June 27, 2008). While the terrain along much of Townsend-Winona is conducive to pathway placement, sections of the existing roadway are elevated, which would require retaining walls or right-of-way acquisition. The corridor includes long segments adjacent to U. S. Forest Service lands, where it may be desirable to place the path. Coordination with U.S. Forest Service will be required. A roundabout is proposed (by the Townsend-Winona Final Engineering Study) at Koch Field Road.</p>



**Project Information Sheet 27 – Townsend-Winona-3**

<b>Project No.</b>	Townsend-Winona-3
<b>Project Name</b>	Townsend-Winona Road, Koch Field Road to Slayton Ranch Road, Shared-use Path
<b>Project Length</b>	2.72 miles
<b>Project Objective</b>	<ul style="list-style-type: none"> <li>Construct a 10' paved path on the north side of the street; path would meander through U.S. Forest Service lands where available. Primary users of pathway are pedestrians and slow-speed bicyclists. Note that bicycle lanes on Townsend-Winona are provided through Project No. 5, Townsend-Winona 1.</li> <li>Construct a 6' equestrian path on the south side of the street (opposite paved path). Construct railing-fence barrier (52" maximum) separating equestrian tread and vehicular lanes. Equestrian path will be constructed of natural materials suitable to horses.</li> <li>Evaluate need for marked pedestrian crossing/ pedestrian crossing beacon at Townsend-Winona Road/ Slayton Ranch Road intersection. A roundabout is proposed in the Townsend-Winona Corridor Study.</li> </ul>
<b>Project Need / Community Benefit</b>	This road is one of the higher volume streets in the Doney Park area; a shared-use path will accommodate pedestrians and slow-speed bicyclists; equestrians are accommodated on a separated soft path.
<b>2011 Total Cost Estimate</b>	\$1,060,000
<b>A. Scoping</b>	\$100,000
<b>B. Design (30%, 60%, 95-100%)</b>	\$230,000
<b>C. Construction</b>	\$730,000
<b>Comments</b>	<p>Path design and construction should be coordinated with planned Townsend-Winona roadway improvements (Final Engineering Study for Townsend-Winona Road, Jct. 89 to Jct. I-40, Leupp Road, Jct. Townsend-Winona Road, East 1-mile (June 27, 2008). While the terrain along much of Townsend-Winona is conducive to pathway placement, sections of the roadway are elevated, which would require retaining walls or right-of-way acquisition. The corridor includes long segments adjacent to U.S. Forest Service lands, where it may be desirable to place the path. Coordination with U.S. Forest Service will be required. At Koch Field Road, the path crosses from the south side of the road to the north side. A roundabout is proposed (by the Townsend-Winona Final Engineering Study) at this intersection.</p>



**Project Information Sheet 28 – Townsend-Winona-4**

<b>Project No.</b>	Townsend-Winona-4
<b>Project Name</b>	Townsend-Winona Road, Slayton Ranch Road to Leupp Road, Shared-use Path
<b>Project Length</b>	2.85 miles
<b>Project Objective</b>	<ul style="list-style-type: none"> <li>• Construct a 10' paved path on the north of the street; path would meander through U.S. Forest Service Lands where available. Coordination with U.S. Forest Service required. Primary users of pathway are pedestrians and low-speed bicyclists.</li> <li>• Construct a 6' equestrian path on the south side of the street (opposite paved path). Construct barrier (52" maximum) between equestrian tread and vehicular lanes. Path will be constructed of natural materials suitable to horses. Note that bicycle lanes are provided through Project No. 5 - Townsend-Winona 1.</li> </ul>
<b>Project Need / Community Benefit</b>	This road is one of the higher volume streets in the Doney Park area; a shared-use path will accommodate pedestrians and slow-speed bicyclists; equestrians are accommodated on a separated soft path.
<b>2011 Total Cost Estimate</b>	\$1,090,000
<b>A. Scoping</b>	\$100,000
<b>B. Design (30%, 60%, 95-100%)</b>	\$230,000
<b>C. Construction</b>	\$755,000
<b>Comments</b>	<p>Path design and construction should be coordinated with planned Townsend-Winona roadway improvements (Final Engineering Study for Townsend-Winona Road, Jct. 89 to Jct. I-40, Leupp Road, Jct. Townsend-Winona Road, East 1-mile (June 27, 2008). While the terrain along much of Townsend-Winona is conducive to pathway placement, sections of the roadway are elevated, which would require retaining walls or right-of-way acquisition. The corridor includes long segments adjacent to U.S. Forest Service lands, where it may be desirable to place the path. Coordination with U.S. Forest Service will be required.</p>



**Project Information Sheet 29 – Townsend-Winona-5**

<b>Project No.</b>	Townsend-Winona Road-5
<b>Project Name</b>	Townsend-Winona Road, Leupp Road to Jobe Road ( <sup>1</sup> ). Shared-use Path
<b>Project Length</b>	1.99 miles
<b>Project Objective</b>	<ul style="list-style-type: none"> <li>Construct a 10' paved path on the north of the street; path would meander through U.S. Forest Service Lands where available. Primary users of pathway are pedestrians and low-speed bicyclists. Note that bicycle lanes are provided through Project No. 5 - Townsend-Winona 1.</li> <li>Construct a 6' equestrian path on the south side of the street (opposite paved path). Construct barrier (52" maximum) between equestrian tread and vehicular lanes. Path will be constructed of natural materials suitable to horses.</li> </ul>
<b>Project Need / Community Benefit</b>	This road is one of the higher volume streets in the Doney Park area and a shared-use path will provide access to U.S. Forest Service trails and other land uses.
<b>2011 Total Cost Estimate</b>	\$675,000
<b>A. Scoping</b>	\$75,000
<b>B. Design (30%, 60%, 95-100%)</b>	\$140,000
<b>C. Construction</b>	\$460,000
<b>Comments</b>	<p>Path design and construction should be coordinated with planned Townsend-Winona roadway improvements (Final Engineering Study for Townsend-Winona Road, Jct. 89 to Jct. I-40, Leupp Road, Jct. Townsend-Winona Road, East 1-mile (June 27, 2008). While the terrain along much of Townsend-Winona is conducive to pathway placement, sections of the roadway are elevated, which would require retaining walls or right-of-way acquisition. The corridor includes long segments adjacent to U.S. Forest Service lands, where it may be desirable to place the path. Coordination with U.S. Forest Service will be required.</p> <p>A historic bridge between Copley Road and Duck Road can be incorporated into the pathway alignment.</p> <p><u>Note:</u></p> <p>1. Extending the pathways east to Winona/I-40 may be considered. The existing bridge on Townsend-Winona Road that connects to I-40 presents a design constraint. Alternative alignments will be required. A logical terminus for the pathway needs to be identified. Future improvements at this interchange should consider multimodal connectivity to Townsend-Winona road pathways.</p>



**Project Information Sheet 30 – US 89-1**

<b>Project No.</b>	US 89-1
<b>Project Name</b>	US 89 Sidewalk Project (900 feet south of Townsend-Winona Road to Townsend-Winona Road Intersection)
<b>Project Length</b>	0.33 miles (total of both sides of US 89)
<b>Project Objective</b>	Construct 6'-wide sidewalks on both sides of US 89, from the end of the existing sidewalk north to Townsend-Winona Road.
<b>Project Need / Community Benefit</b>	Construction of sidewalks on both sides on US 89 would complete a link to Townsend-Winona Road, a major east-west roadway.
<b>2011 Total Cost Estimate</b>	\$85,000
<b>A. Scoping</b>	\$0 (if completed through on-call or Job Order Contract or other local procurement process)
<b>B. Design (30%, 60%, 95-100%)</b>	\$5,000
<b>C. Construction</b>	\$80,000
<b>Comments</b>	<p>The Townsend-Winona-2 project describes a connection of proposed US 89 sidewalk /path (US 89-1) and Townsend-Winona path to the Arizona Trail.</p> <p>US 89-1 differs from US 89-2 in that US 89-1 proposes a pathway that is separated from US 89 and located west of US 89 on U.S. Forest Service land.</p> <p>ADOT policy requires that sidewalk/pathway improvements within ADOT right of way be maintained by local government through a JPA/IGA with ADOT.</p>



Northwest corner of Townsend-Winona Road/ US 89, viewing south



**Project Information Sheet 31 – US 89-2**

<b>Project No.</b>	US 89-2
<b>Project Name</b>	US 89 Shared-use Path Connection to the Flagstaff Urban Trail System
<b>Project Length</b>	0.75 miles
<b>Project Objective</b>	<p>Construct a paved 10'-wide shared-use path on west side of US 89 that connects to existing FUTS at Snowflake/Trails. Path would route behind existing development onto U.S. Forest Service lands.</p> <p>This project differs from US 89-1 in that it is separated from the roadway and may traverse west of and behind existing development adjacent to or on U.S. Forest Service land. Coordination with the U.S. Forest Service is required.</p> <p>Project US 89-1 proposes a sidewalk adjacent to the roadway.</p>
<b>Project Need / Community Benefit</b>	This segment will complete a shared-use path extending from Campbell Avenue to the FUTS system.
<b>2011 Total Cost Estimate</b>	\$265,000
<b>A. Scoping</b>	\$40,000
<b>B. Design (30%, 60%, 95-100%)</b>	\$55,000
<b>C. Construction</b>	\$170,000
<b>Comments</b>	ADOT policy requires that sidewalk/pathway improvements within ADOT right of way be maintained by local government through a JPA/IGA with ADOT.



**Project Information Sheet 32 – US 89-3**

<b>Project No.</b>	US 89-3
<b>Project Name</b>	US 89, Shared-use Path, Townsend-Winona Road to Silver Saddle Road
<b>Project Length</b>	3.74 miles (both sides)
<b>Project Objective</b>	Construct a paved 10'-wide asphalt shared-use path on the east and west sides of US 89.
<b>Project Need / Community Benefit</b>	One of the policies in the Doney Park Timberline Fernwood Area Plan was that non-motorized trails that parallel Highway 89, collector roadways, and other paved roads should be separated from the roadway where feasible.
<b>2011 Total Cost Estimate</b>	\$1,255,000
<b>A. Scoping</b>	\$100,000
<b>B. Design (30%, 60%, 95 - 100%)</b>	\$150,000
<b>C. Construction</b>	\$1,005,000
<b>Comments</b>	Short sections at culvert crossing and driveways are proposed to be constructed of concrete. ADOT policy requires that sidewalk/pathway improvements within ADOT right of way be maintained by local government through a JPA/IGA with ADOT.
	
<p>US 89, looking south</p>	



**Project Information Sheet 33 – US89-4**

<b>Project No.</b>	US89-4
<b>Project Name</b>	US 89 Shared-use path, Silver Saddle Road to Copeland Lane
<b>Project Length</b>	2.88 miles
<b>Project Objective</b>	Construct a paved 10'-wide shared-use path on the west side of the street.  <i>NOTE: Additional investigation is required to determine the feasibility of a pathway extending north of Campbell Ave. due to recent drainage improvements. Additional drainage improvements may be constructed in the area. Pathway may not be feasible within ADOT right-of-way north of Campbell Ave.</i>
<b>Project Need / Community Benefit</b>	One of the policies in the Doney Park Timberline Fernwood Area Plan was that non-motorized trails that parallel Highway 89, collector roadways, and other paved roads should be separated from the roadway where feasible.
<b>2011 Total Cost Estimate</b>	\$950,000
<b>A. Scoping</b>	\$85,000
<b>B. Design (30%, 60%, 95-100%)</b>	\$110,000
<b>C. Construction</b>	\$755,000
<b>Comments</b>	Caution should be used in the design of the pathway crossing driveways and side streets. Concrete may be required at drainage and swale crossings. ADOT policy requires that sidewalk/pathway improvements within ADOT right of way be maintained by local government through a JPA/IGA with ADOT.



US 89 at Copeland Road



**Project Information Sheet 34 – US 89-5**

<b>Project No.</b>	US 89-5
<b>Project Name</b>	US 89 Pedestrian and Equestrian Crossings
<b>Project Length</b>	N/A
<b>Project Objective</b>	<p>Construct grade-separated crossings of US 89. Grade-separated crossings would accommodate pedestrians and unmounted equestrians.</p> <p>Stakeholders have suggested that grade-separated crossings be constructed in conjunction with future (not yet specified) drainage improvements. While this should be considered, grade separations under US 89 would require expensive modifications of US 89, including the re-profiling of US 89. Forthcoming drainage improvements crossing US 89 may not necessitate extensive re-profiling of US 89.</p> <p>An alternative to crossings under US 89 are crossings over US 89 that are designed to accommodate pedestrians and unmounted equestrians.</p>
<b>Project Need / Community Benefit</b>	Stakeholders including pedestrians and equestrians have expressed a need for controlled or grade-separated crossings of US 89 for pedestrians and equestrians.
<b>2011 Total Cost Estimate</b>	To be determined during concept development. Grade-separated facility under or over US 89 is anticipated to cost millions of dollars.
<b>A. Scoping</b>	
<b>B. Design (30%, 60%, 95-100%)</b>	
<b>C. Construction</b>	
<b>Comments</b>	<p>As drainage improvements are developed, opportunities for grade-separated crossings should be identified.</p> <p>ADOT policy requires that sidewalk/pathway improvements within ADOT right of way be maintained by local government through a JPA/IGA with ADOT.</p>



**Project Information Sheet 35 – US 89-6**

<b>Project No.</b>	US 89-6
<b>Project Name</b>	US 89 Lane Width Narrowing to Accommodate Paved Shoulder, City of Flagstaff City Limit to Townsend-Winona Road
<b>Project Length</b>	0.48 miles
<b>Project Objective</b>	Restripe existing 12' travel lanes to provide paved shoulder: Potential lane width configuration is: 3'-11'-11'-10'-11'-11'-3'; engineering study required to determine suitability of lane width reduction consideration travel speeds and traffic volumes. This configuration is similar to that implemented elsewhere within the City of Flagstaff.
<b>Project Need / Community Benefit</b>	This will connect the paved shoulders on US 89 to the bicycle lanes within the City of Flagstaff.
<b>2011 Total Cost Estimate</b>	The cost of installing a bike lane is approximately \$5,000 to \$50,000 per mile, depending on the condition of the pavement, the need to remove and repaint the lane lines, and other factors. Assumed a planning-level cost of \$25,000.
<b>A. Scoping</b>	\$0 (if completed through on-call or Job Order Contract or other local procurement process)
<b>B. Design (30%, 60%, 95-100%)</b>	Modest to minimal cost if designed with on-call or in-house resources.
<b>C. Construction</b>	Modest to minimal cost if constructed through Job-Order Contract or with ADOT striping crews.
<b>Comments</b>	ADOT policy requires that sidewalk/pathway improvements within ADOT right of way be maintained by local government through a JPA/IGA with ADOT.

**Project Information Sheet 36 – Yancey-1**

<b>Project No.</b>	Yancey-1
<b>Project Name</b>	Yancey Lane, Koch Field Road to Stardust Trail, Shoulder Improvements
<b>Project Length</b>	1.03
<b>Project Objective</b>	Widen shoulders to allow restriping to provide 4' asphalt shoulder on each side of the road. Shoulders on low traffic volume roads provide a suitable pedestrian facility where right-of-way is constrained. If necessary, travel lanes may be reduced to 10'- to 11'-wide to minimize widening.
<b>Project Need / Community Benefit</b>	Provides connectivity between Koch Field Road and Stardust Trail
<b>2011 Total Cost Estimate</b>	\$255,000
<b>A. Scoping</b>	\$40,000
<b>B. Design (30%, 60%, 95-100%)</b>	\$50,000
<b>C. Construction</b>	\$165,000
<b>Comments</b>	



Yancey Lane, at Koch Field Road Intersection

Photo Source: Google



**Project Information Sheet 37 – Transit-1**

<b>Project No.</b>	Transit-1
<b>Project Name</b>	Doney Park Area Transit Service
<b>Project Length</b>	N/A
<b>Project Objective</b>	Provide transit service to Doney Park area (specific route and frequency to be determined).
<b>Project Need / Community Benefit</b>	Transit service was a need expressed by the public and in a number of regional transit studies.
<b>2011 Total Cost Estimate</b>	To be determined in collaboration with NAIPTA
<b>A. Scoping</b>	
<b>B. Design (30%, 60%, 95-100%)</b>	
<b>C. Construction</b>	
<b>Comments</b>	

**Project Information Sheet 38 – Transit-2**

<b>Project No.</b>	Transit-2
<b>Project Name</b>	US 89 Van Pool / Park and Ride locations at Burris Lane, Silver Saddle Road, and Campbell Ave
<b>Project Length</b>	N/A
<b>Project Objective</b>	Provide vanpool / park-and-ride lots on US 89 at Burris Lane, Silver Saddle Road, Campbell Avenue, location to be determined.
<b>Project Need / Community Benefit</b>	Transit service was a need expressed by the public and in a number of regional transit studies. Prior to implementing transit service, vanpool lots could provide a way to increase carpooling.
<b>2011 Total Cost Estimate</b>	To be determined in collaboration with NAIPTA.
<b>A. Scoping</b>	
<b>B. Design (30%, 60%, 95-100%)</b>	
<b>C. Construction</b>	
<b>Comments</b>	N/A



**Project Information Sheet 39 – Transit-3**

<b>Project No.</b>	Transit-3
<b>Project Name</b>	Doney Park Van Pool/ Park and Ride Lots
<b>Project Length</b>	N/A
<b>Project Objective</b>	Provide vanpool / park-and-ride lots at location to be determined; potentially near vicinity of Silver Saddle Road and Koch Field Road.
<b>Project Need / Community Benefit</b>	Park-and-ride lots may encourage carpooling, reducing reliance on the single occupancy vehicle.
<b>2011 Total Cost Estimate</b>	To be determined in collaboration with NAIPTA.
<b>A. Scoping</b>	
<b>B. Design (30%, 60%, 95-100%)</b>	
<b>C. Construction</b>	
<b>Comments</b>	N/A